

# STANDARDS COMMITTEE FOR HI-LOK® HI-TIGUE® PRODUCTS

2600 SKYPARK DRIVE, TORRANCE, CALIFORNIA 90509 U.S.A.

HI-SHEAR CORPORATION, U.S.A. (Patent Holder) CAGE No. 73197  
 a LISI AEROSPACE Company  
 AIR INDUSTRIES CO., INC., U.S.A. (Licensee - U.S.A. & Canada) CAGE No. 06726  
 HUCK INTERNATIONAL, INC., U.S.A. (Licensee) CAGE No. 97926  
 SPS TECHNOLOGIES, U.S.A. (Licensee) CAGE No. 56878  
 FAIRCHILD Aerospace Fastener Division (Licensee) CAGE No. 92215  
 WEST COAST AEROSPACE INC., U.S.A. (Licensee) CAGE No. 60516  
 (Pins & Steel Collars)

BLANC AERO INDUSTRIES UK LIMITED (Licensee) CAGE No. 0LB68  
 a LISI AEROSPACE Company  
 HUCK S.A. France (Licensee - ECC Countries)  
 BLANC AERO S.A. France (Licensee - ECC Countries)  
 a LISI AEROSPACE Company  
 TOKYO SCREW COMPANY, Japan (Licensee - Japan)

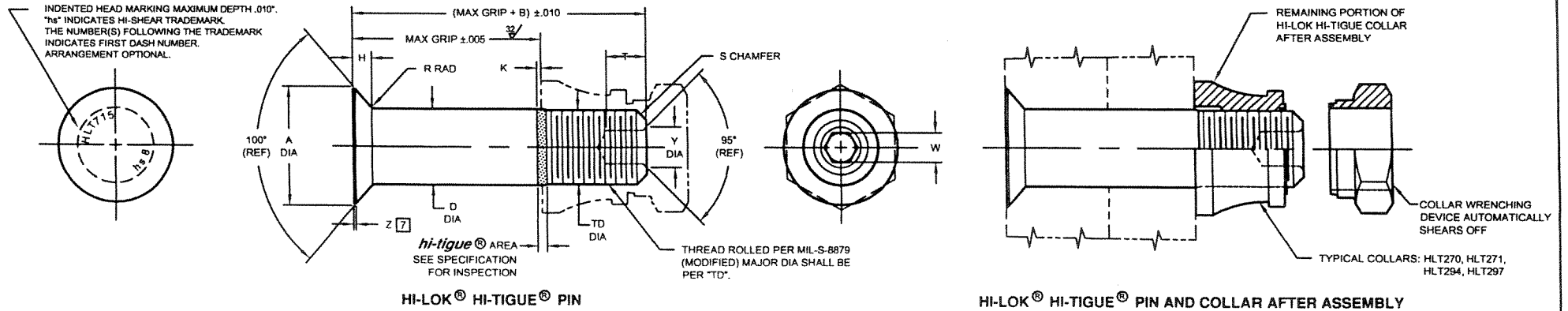

HI-LOK® HI-TIGUE® PIN

HI-LOK® HI-TIGUE® PIN AND COLLAR AFTER ASSEMBLY

FIRST DASH NO.	PIN NOM DIA	A DIA	B REF	D DIA		TD DIA	F	H	K REF	R RAD.	Z MAX.	S CHAMFER REF	THREAD	SOCKET			DOUBLE SHEAR POUNDS MINIMUM	TENSION POUNDS MINIMUM
				WITHOUT PLATING S.F.L. OR COATING	WITH PLATING S.F.L. OR COATING									W HEX	T DEPTH	Y DIA		
NOTE: USE HLT421 ( ) 6(-)																		
6	7/32	.3308 .3253	.360	.2182 .2177	.2182 .2172	.1840 .1810	.005	.0472 .0449	.016	.030 .020	.015	1/32" x 45°	10-32UNJF-3A Modified	.0806 .0791	.100 .080	.119 .104	9,400	2,600
8	9/32	.4265 .4210	.435	.2807 .2802	.2807 .2797	.2440 .2410	.006	.0612 .0589	.021	.030 .020	.015	1/32" x 45°	1/4-28UNJF-3A Modified	.0967 .0947	.110 .090	.142 .122	15,500	4,400
10	11/32	.5056 .5001	.545	.3432 .3427	.3432 .3422	.3060 .3020	.007	.0681 .0658	.026	.040 .030	.015	3/64" x 45°	5/16-24UNJF-3A Modified	.1295 .1270	.130 .110	.180 .160	23,200	7,000
12	13/32	.5921 .5866	.590	.4057 .4052	.4057 .4047	.3680 .3640	.008	.0782 .0759	.030	.040 .030	.015	3/64" x 45°	3/8-24UNJF-3A Modified	.1617 .1582	.160 .140	.217 .197	32,400	10,000
14	15/32	.6997 .6932	.690	.4682 .4677	.4682 .4672	.4310 .4260	.009	.0971 .0944	.035	.050 .040	.022	3/64" x 45°	7/16-20UNJF-3A Modified	.1930 .1895	.190 .170	.253 .233	43,100	13,500
16	17/32	.7857 .7792	.740	.5307 .5302	.5307 .5297	.4930 .4880	.010	.1070 .1043	.039	.050 .040	.022	3/64" x 45°	1/2-20UNJF-3A Modified	.2242 .2207	.220 .200	.289 .269	55,400	18,000
18	19/32	.8692 .8622	.825	.5927 .5922	.5927 .5917	.5550 .5500	.010	.1160 .1130	.039	.050 .040	.022	1/16" x 45°	9/16-18UNJF-3A Modified	.2555 .2520	.260 .240	.326 .306	69,200	22,500
20	21/32	.9562 .9492	.890	.6552 .6547	.6552 .6542	.6180 .6120	.010	.1260 .1230	.044	.050 .040	.022	1/16" x 45°	5/8-18UNJF-3A Modified	.2555 .2520	.260 .240	.326 .306	84,500	27,000
24	25/32	1.1282 1.1162	1.115	.7802 .7797	.7802 .7792	.7430 .7370	.012	.1460 .1410	.044	.050 .040	.022	1/16" x 45°	3/4-16UNJF-3A Modified	.3185 .3150	.330 .300	.398 .378	120,000	37,300

SEE COLLAR STANDARDS FOR COLLAR STRENGTHS. LOWER STRENGTH (PIN OR COLLAR) DETERMINES SYSTEM STRENGTH.

- GENERAL NOTES:**
- Head edge out of roundness shall not exceed "F".
  - Concentricity: Conical surface of head to "D" diameter within .005 FIR.
  - "H" is dimensioned from maximum "D" diameter.
  - Dimensions to be met after finish.
  - Surface texture per ANSI B46.1.
  - Hole preparation per NAS618.

- Curved or flat edge manufacturer's option.
- Oversize pin for HLT421 and HLT621.

**MATERIAL:** Nickel base alloy per AMS5662.  
**HEAT TREAT:** 125,000 psi shear minimum (210,000 psi tensile minimum).

- FINISH:**
- HLT715(-)(-) = Passivate per Hi-Shear Spec. 258, and cetyl alcohol lube per Hi-Shear Spec. 305.
  - HLT715AP(-)(-) = Hi-Kote 1 aluminum coating per Hi-Shear Spec. 294, and cetyl alcohol lube per Hi-Shear Spec. 305.
  - HLT715DL(-)(-) = Solid film lube per AS5272, Type I, and cetyl alcohol lube per Hi-Shear Spec. 305.
  - HLT715PB(-)(-) = Cadmium plate per AMS-QQ-P-416, Type II, Class 2, and cetyl alcohol lube per Hi-Shear Spec. 305.
  - HLT715FB(-)(-) = Grit blast top of head, passivate per Hi-Shear Spec 258 and cetyl alcohol lube per Hi-Shear Spec. 305.
  - HLT715FJ(-)(-) = Hi-Kote 2 solid film lube per Hi-Shear Spec. 292, color red on thread end, and cetyl alcohol lube per Hi-Shear Spec. 305.
  - HLT715SK(-)(-) = Grit blast top of head, passivate per Hi-Shear Spec 258, with color brown on thread end, and cetyl alcohol lube per Hi-Shear Spec. 305.

**SPECIFICATION:**

**CODE:**

**HOW TO ORDER EXAMPLE:**

- HLT715SP(-)(-) = Hi-Kote 2 solid film per Hi-Shear Spec. 292, with color brown on thread end, and cetyl alcohol lube per Hi-Shear Spec. 305.
- HLT715TB(-)(-) = Hi-Kote 2 solid film lube per Hi-Shear Spec. 292, and cetyl alcohol lube per Hi-Shear Spec. 305.
- HLT715FF(-)(-) = Cadmium plate per AMS-QQ-P-416, Type II, Class 2, with color red on thread end, and cetyl alcohol lube per Hi-Shear Spec. 305.

Hi-Lok Hi-Tigue Product Specification 342.

**CODE:** First dash number indicates nominal diameter in 1/32nds of the pin which HLT715 oversize pin replaces. Second dash number indicates maximum grip in 1/16ths. See Finish note for explanation of code letters.

Pin Part Number Only

HLT715-8-8

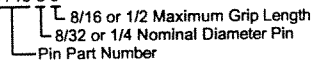

*Hi-Lok*, *HL*, Hi-Tigue, and *HLT* are internationally registered trademark of Hi-Shear Corporation.		
DRAWN	DATE	TITLE
D.P.S.	2-8-85	<b>HI-LOK® HI-TIGUE® PIN</b>
100° FLUSH SHEAR HEAD NICKEL BASE ALLOY (INCONEL 718) 1/16" GRIP VARIATION, 1/32" OVERSIZE		
APPROVED	DATE	DRAWING NUMBER
J.Wilcox	2-11-85	<b>HLT715</b>
REVISION	DATE	
(8)	JO 8-20-02	