

MODEL HM00-96553

Flyback Transformers

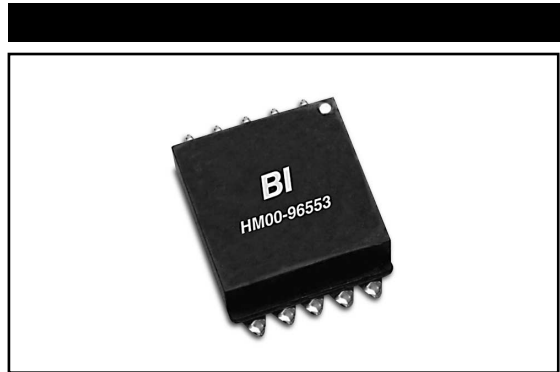

FEATURES

- Subscriber line interface for ISDN power conversion plus supply current for ring voltage
- Used in combination with Linear Technology LT1269CQ device

BENEFITS

- Low profile, compact design
- Dual function power output
- Wide input voltage, 5V to 18V
- Surface mountable, auto placement
- Low noise toroidal design
- Tray or tape & reel packaging

ELECTRICAL

Primary Inductance at 1.0 kHz (1-10)	35 - 45 μ H
Primary Inductance at 1.0 kHz and 3.5 A DC (1-10)	21 μ H Min.
Leakage Inductance at 100 kHz (1-10)	1.5 μ H Max., short of all windings
Dielectric Breakdown Voltage	300V rms
Primary Winding DC Resistance (1-10)	63m Ω Max.

Specifications subject to change without notice.

OUTLINE DIMENSIONS (Inch/mm)

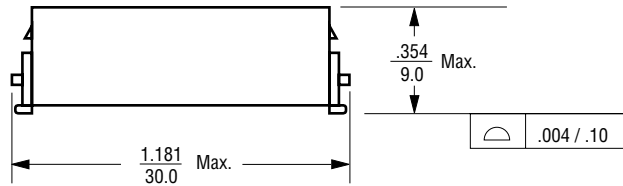
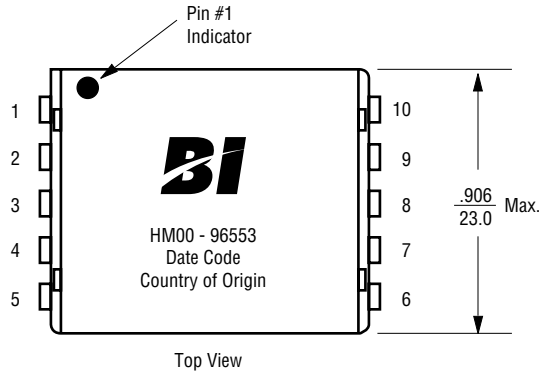

RECOMMENDED PCB LAYOUT

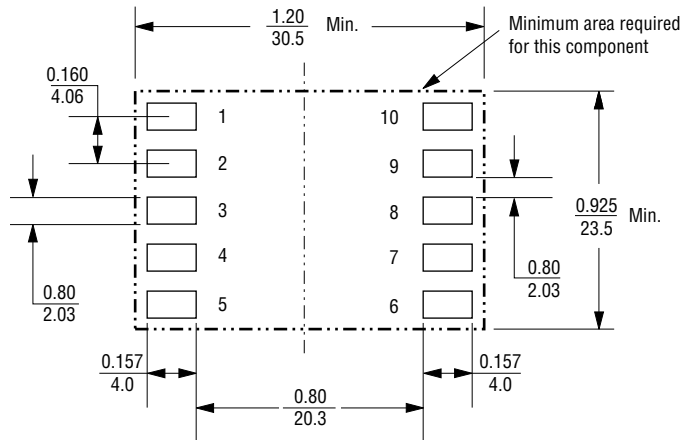

SCHEMATIC

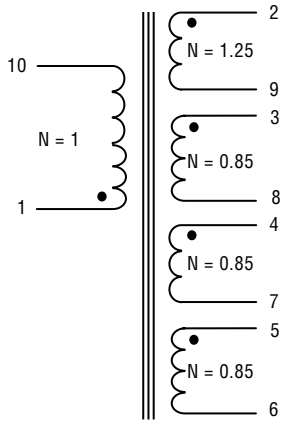

TYPICAL APPLICATION DIAGRAM

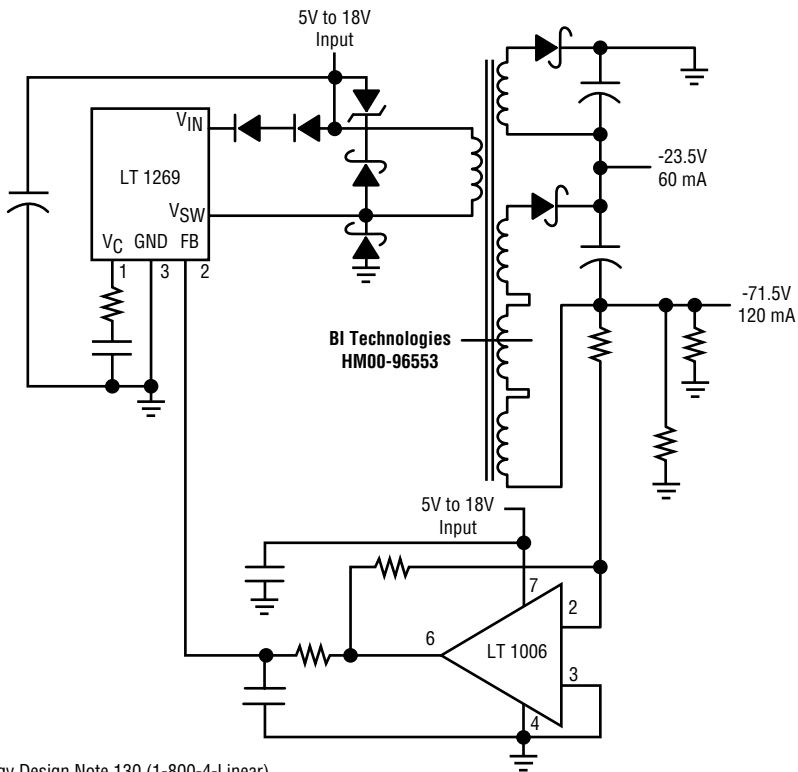

Refer to Linear Technology Design Note 130 (1-800-4-Linear)

PACKAGING

Standard: Tray Pack

Tray	Capacity	=	40 Units
------	----------	---	----------

Option: Embossed Tape & Reel

Reel	Diameter	=	13" (330mm)
	Capacity	=	150 Units