



PROPRIETARY NOTE
THIS SPECIFICATION IS THE PROPERTY OF BOE HF AND SHALL NOT BE REPRODUCED OR COPIED WITHOUT THE WRITTEN PERMISSION OF BOE HF AND MUST BE RETURNED TO BOE HF UPON ITS REQUEST

SPEC. NUMBER

PRODUCT GROUP
TFT-LCD

Rev. O

2011.07.05

PAGE
1 OF 27

TITLE : B3 HM185WX3-300 Open Cell
Product Specification
Rev.O

HEFEI BOE OPTOELECTRONICS TECHNOLOGY



京东方
BOE

PRODUCT GROUP

REV

ISSUE DATE

TFT- LCD PRODUCT

Rev. O

2011.07.05

SPEC. NUMBER

B3 HM185WX3-300 Open Cell Product Specification_ Rev.O

PAGE

2 OF 27

REVISION HISTORY

REV.	ECN No.	DESCRIPTION OF CHANGES	DATE	PREPARED
O		Initial Release	2011.07.05	张文浩

**PRODUCT GROUP**

REV

ISSUE DATE

TFT- LCD PRODUCT

Rev. O

2011.07.05

SPEC. NUMBER

B3 HM185WX3-300 Open Cell Product Specification_ Rev.O

PAGE

3 OF 27

Contents

No.	Item	Page
1.0	General Description	4
2.0	Absolute Maximum Ratings	6
3.0	Electrical Specifications	7
4.0	Optical Specifications	8
5.0	Interface Connection	10
6.0	Signal Timing Specifications	13
7.0	Signal Timing Waveforms of Interface Signal	15
8.0	Input Signals, Display Colors & Gray Scale of Colors	17
9.0	Power Sequence	18
10.0	Mechanical Characteristics	19
11.0	Reliability Test	20
12.0	Handling& Cautions	21
13.0	Product Serial Number	22

1.0 GENERAL DESCRIPTION

1.1 Introduction

HM185WX3-300 is a color active matrix TFT LCD open cell using amorphous silicon TFT's (Thin Film Transistors) as an active switching devices. This open cell has a 18.5 inch diagonally measured active area with WXGA resolutions (1366 horizontal by 768 vertical pixel array). Each pixel is divided into RED, GREEN, BLUE dots which are arranged in vertical stripe and this open cell can display 16.7M colors. The TFT-LCD panel used for this open cell is adapted for a low reflection and higher color type.

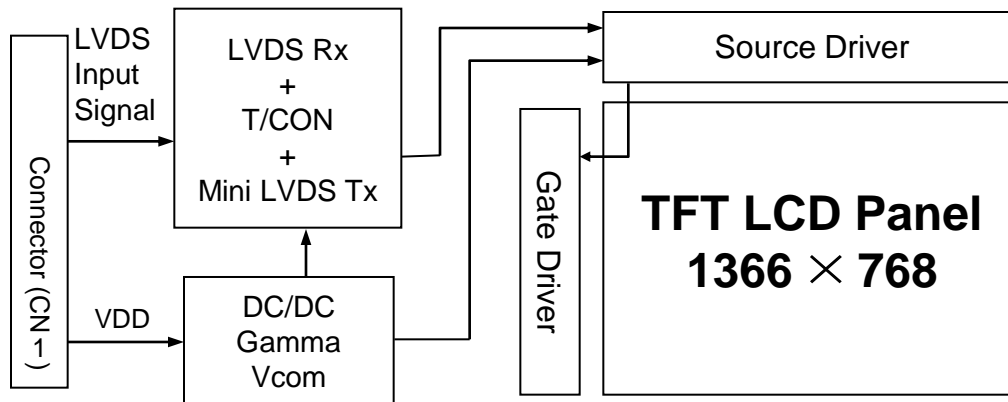

1.2 Features

- LVDS Interface with 1 pixel / clock
- High-speed response
- 6-bit (Hi-FRC) color depth, display 16. 7M colors
- Low reflection and wide viewing angle
- DE (Data Enable) only
- RoHS /TCO 5.0 Compliant
- Gamma Correction

1.3 Application

- Desktop Type of PC & Workstation Use
- Slim-Size Display for Stand-alone Monitor
- Display Terminals for Control System
- Monitors for Process Controller

1.4 General Specification

The followings are general specifications at the open cell HM185WX3-300.

<Table 1. General Specifications>

Parameter	Specification	Unit	Remarks
Active area	409.8(H) × 230.4(V)	mm	
Number of pixels	1366(H) × 768(V)	pixels	
Pixel pitch	0.3(H) × 0.3(V)	mm	
Pixel arrangement	RGB Vertical stripe		
Display colors	16.7M	colors	
Display mode	Normally White		
Weight	500 (max.)	g	
Surface Treatment	Haze 25%, 3H		

2.0 ABSOLUTE MAXIMUM RATINGS

The followings are maximum values which, if exceed, may cause faulty operation or damage to the unit. The operational and non-operational maximum voltage and current values are listed in Table 2.

< Table 2. Absolute Maximum Ratings >

[VSS=GND=0V]

Parameter	Symbol	Min.	Max.	Unit	Remarks
Power Supply Voltage	V_{DD}	-0.5	5.5	V	Ta = 25 °C
Logic Supply Voltage	V_{IN}	VSS-0.3	$V_{DD}+0.3$	V	
Operating Temperature	T_{OP}	0	+50	°C	1)
Storage Temperature	T_{ST}	-20	+60	°C	1)

Note : 1) Temperature and relative humidity range are shown in the figure below.

Wet bulb temperature should be 39 °C max. and no condensation of water.

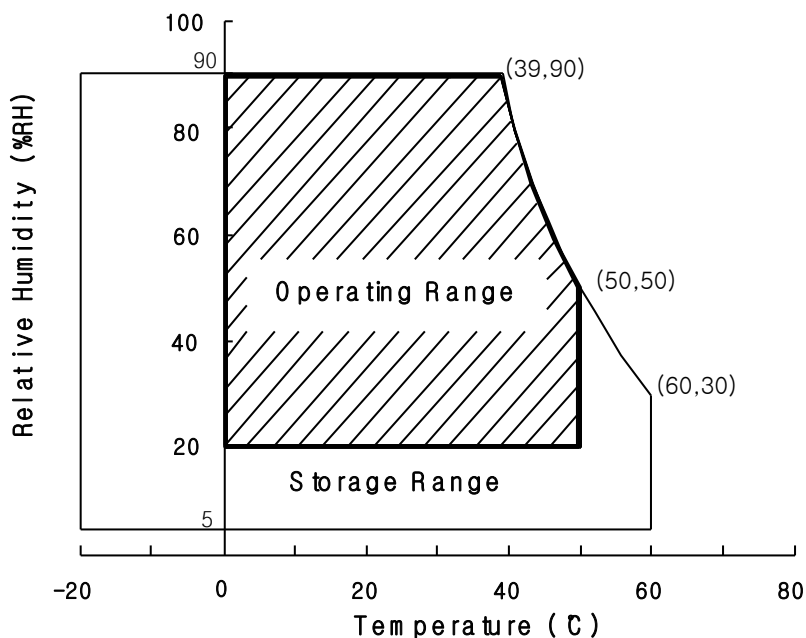

3.0 ELECTRICAL SPECIFICATIONS

3.1 Electrical Specifications

< Table 3. Electrical specifications >

[Ta =25±2 °C]

Parameter		Min.	Typ.	Max.	Unit	Remarks
Power Supply Voltage	V _{DD}	4.5	5.0	5.5	V	Note1
Power Supply Current	I _{DD}	-	600	1000	mA	
In-Rush Current	I _{RUSH}	-	2.0	3.0	A	Note 2
Permissible Input Ripple Voltage	V _{RF}	-	-	100	mV	V _{DD} = 5.0V
High Level Differential Input Threshold Voltage	V _{IH}	-	-	+100	mV	
Low Level Differential Input Threshold Voltage	V _{IL}	-100	-	-	mV	
Differential input voltage	V _{ID}	200	-	600	mV	
Differential input common mode voltage	V _{cm}	1.0	1.2	1.5		V _{IH} =100mV, V _{IL} =-100mV
Power Consumption	P _D	-	3	4.5	W	

- Notes : 1. The supply voltage is measured and specified at the interface connector of LCM.
The current draw and power consumption specified is for VDD=5.0V, Frame rate=75Hz and
Clock frequency = 95MHz. Test Pattern of power supply current
a) Typ : Color Bar pattern
b) Max : Skip Sub Pixel Pattern

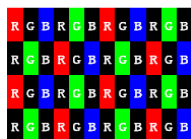

2. Duration of rush current is about 2 ms and rising time of VDD is 520 μs ± 20 %

4.0 OPTICAL SPECIFICATION

4.1 Overview

The test of Optical specifications shall be measured in a dark room (ambient luminance ≤ 1 lux and temperature = $25 \pm 2^\circ\text{C}$) with the equipment of Luminance meter system (Goniometer system and TOPCONE BM-5) and test unit shall be located at an approximate distance 50cm from the LCD surface at a viewing angle of θ and Φ equal to 0° . We refer to $\theta_{\theta=0}$ ($=\theta_3$) as the 3 o'clock direction (the "right"), $\theta_{\theta=90}$ ($=\theta_{12}$) as the 12 o'clock direction ("upward"), $\theta_{\theta=180}$ ($=\theta_9$) as the 9 o'clock direction ("left") and $\theta_{\theta=270}$ ($=\theta_6$) as the 6 o'clock direction ("bottom"). While scanning θ and/or Φ , the center of the measuring spot on the Display surface shall stay fixed. The measurement shall be executed after 30 minutes warm-up period. VDD shall be 5.0V +/-10% at 25°C . Optimum viewing angle direction is 6'clock.

4.2 Optical Specifications

[VDD = 5.0V, Frame rate = 60Hz, Clock = 78MHz, $I_{BL} = 7.5\text{mA}$, $T_a = 25 \pm 2^\circ\text{C}$]

Parameter		Symbol	Condition	Min.	Typ.	Max.	Unit	Remark
Viewing Angle range	Horizontal	θ_3	CR > 10	70	85	-	Deg.	Note 2
		θ_9		70	85	-	Deg.	
	Vertical	θ_{12}		70	80	-	Deg.	
		θ_6		70	80	-	Deg.	
Viewing Angle range	Horizontal	θ_3	CR > 5	85	-	-	Deg.	
		θ_9		85	-	-	Deg.	
	Vertical	θ_{12}		85	-	-	Deg.	
		θ_6		85	-	-	Deg.	
Luminance Contrast ratio		CR		700	1000			Note 3
Cell Transmittance		Tr		-	5.4	-	%	Note 4
White luminance uniformity		ΔY		75	80		%	Note 5
Reproduction of color	White	W_x	$\theta = 0^\circ$ (Center) Normal Viewing Angle	0.283	0.313	0.343		Note 6
		W_y		0.299	0.329	0.359		
	Red	R_x		0.606	0.636	0.666		
		R_y		0.313	0.343	0.373		
	Green	G_x		0.297	0.327	0.357		
		G_y		0.599	0.629	0.659		
	Blue	B_x		0.124	0.154	0.184		
		B_y		0.018	0.048	0.078		
Response Time	Rising	T_r			1.5	2.5	ms	Note 7
	Falling	T_f			3.5	5.5	ms	
Cross Talk		CT		-	-	2.0	%	Note 8



Note :

1. The value in upper table are based on BLU provided by BOEHF.
2. Viewing angle is the angle at which the contrast ratio is greater than 10. The viewing are determined for the horizontal or 3, 9 o'clock direction and the vertical or 6, 12 o'clock direction with respect to the optical axis which is normal to the LCD surface.
3. Contrast measurements shall be made at viewing angle of $\theta = 0^\circ$ and at the center of the LCD surface. Luminance shall be measured with all pixels in the view field set first to white, then to the dark (black) state. (See FIGURE 1 shown in Appendix) Luminance Contrast Ratio (CR) is defined mathematically.

$$CR = \frac{\text{Luminance when displaying a white raster}}{\text{Luminance when displaying a black raster}}$$

4. Luminance of LCD module shall be made without signal input. Cell transmittance is defined mathematically, BLU provided by BOEHF.

$$\text{Transmittance} = \frac{\text{Luminance of LCD Module}}{\text{Luminance of BLU}}$$

5. The White luminance uniformity on LCD surface is then expressed as :
 $\Delta Y = (\text{Minimum Luminance of 9points} / \text{Maximum Luminance of 9points}) * 100$
 (See FIGURE 2 shown in Appendix).
6. The color chromaticity coordinates specified in Table 4. shall be calculated from the spectral data measured with all pixels first in red, green, blue and white. Measurements shall be made at the center of the panel with BLU provided by BOEHF.
7. The electro-optical response time measurements shall be made as FIGURE 3 shown in Appendix by switching the "data" input signal ON and OFF. The times needed for the luminance to change from 10% to 90% is Td, and 90% to 10% is Tr.
8. Cross-Talk of one area of the LCD surface by another shall be measured by comparing the luminance (Y_A) of a 25mm diameter area, with all display pixels set to a gray level, to the luminance (Y_B) of that same area when any adjacent area is driven dark. (See FIGURE 4 shown in Appendix).

5.0 INTERFACE CONNECTION.

5.1 Electrical Interface Connection

- CN11 Open Cell Side Connector : UJU IS100-300-C23 or Equivalent
User Side Connector : JAE FI-X30H or Equivalent

Pin No	Symbol	Function	Remark
1	NC	No connection	
2	CE	No connection	internal use
3	CTL	No connection	internal use
4	GND	GND Ground	
5	RX0-	Negative LVDS differential data input. Channel 0	
6	RX0+	Positive LVDS differential data input. Channel 0	
7	GND	Ground	
8	RX1-	Negative LVDS differential data input. Channel 1	
9	RX1+	Positive LVDS differential data input. Channel 1	
10	GND	Ground	
11	RX2-	Negative LVDS differential data input. Channel 2	
12	RX2+	Positive LVDS differential data input. Channel 2	
13	GND	Ground	
14	RXCLK-	Negative LVDS differential clock input.	
15	RXCLK+	Positive LVDS differential clock input.	
16	GND	Ground	
17	RX3-	Negative LVDS differential data input. Channel 3	
18	RX3+	Positive LVDS differential data input. Channel 3	
19	GND	Ground	
20	NC	Not connection, this pin should be open.	
21	NC	Not connection, this pin should be open.	
22	NC	Not connection, this pin should be open.	
23	GND	Ground	
24	GND	Ground	
25	GND	Ground	
26	VCC	5V Power supply	
27	VCC		
28	VCC		
29	VCC		
30	VCC		

5.2 LVDS Interface (Tx; THC63LVDF83A or Equivalent)
5.2.1 LVDS Interface

	Input Signal	Transmitter		Interface		HE185WX1-100 (CN11)	Remark
		Pin No.	Pin No.	System (Tx)	TFT-LCD (Rx)	Pin No.	
LVDS	OR0	51	48 47	OUT0- OUT0+	RX00- RX00+	1	
	OR1	52					
	OR2	54					
	OR3	55					
	OR4	56					
	OR5	3					
	OG0	4	46 45	OUT1- OUT1+	RX01- RX01+	3	
	OG1	6					
	OG2	7					
	OG3	11					
	OG4	12					
	OG5	14					
	OB0	15	42 41	OUT2- OUT2+	RX02- RX02+	5	
	OB1	19					
	OB2	20					
	OB3	22					
	OB4	23					
	OB5	24					
	Hsync	27	40 39	CLK OUT- CLK OUT+	RXO CLK- RXO CLK+	8	
	Vsync	28					
DE	30	38 37	OUT3- OUT3+	RX03- RX03+	10		
MCLK	31						
OR6	50	38 37	OUT3- OUT3+	RX03- RX03+	11		
OR7	2						
OG6	8						
OG7	10						
OB6	16						
OB7	18						
RSVD	25						

5.3 Data Input Format

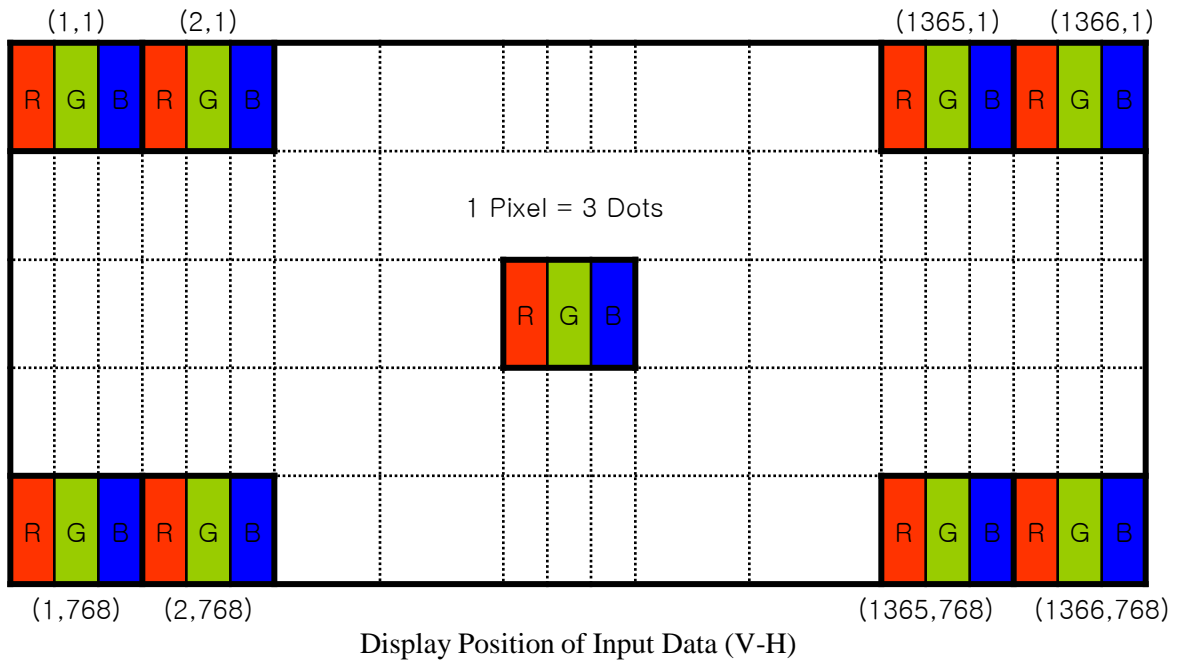

6.0 SIGNAL TIMING SPECIFICATION

6.1 The HM185WX3-300 is operated by the DE only.

Item		Symbols	Min	Typ	Max	Unit
Clock	Frequency	1/Tc	50	78	95	MHz
	High Time	Tch	-	4/7Tc	-	
	Low Time	Tcl	-	4/7Tc	-	
Frame Period		Tv	778	806	888	lines
			50	60	75	Hz
			20	16.7	13.3	ms
Vertical Display Period		Tvd	-	768	-	lines
One line Scanning Period		Th	1446	1560	1936	clocks
Horizontal Display Period		Thd	-	1366	-	clocks

6.2 LVDS Rx Interface Timing Parameter

The specification of the LVDS Rx interface timing parameter is shown in Table 4.

<Table 4. LVDS Rx Interface Timing Specification>

Item	Symbol	Min	Typ	Max	Unit	Remark
CLKIN Period	tRCIP	10.60	13.25	20.00	nsec	
Input Data 0	tRIP1	-0.4	0.0	+0.4	nsec	
Input Data 1	tRIP0	tRCIP/7-0.4	tRCIP/7	tRCIP/7+0.4	nsec	
Input Data 2	tRIP6	2 × tRCIP/7-0.4	2 × tRCIP/7	2 × tRCIP/7+0.4	nsec	
Input Data 3	tRIP5	3 × tRCIP/7-0.4	3 × tRCIP/7	3 × tRCIP/7+0.4	nsec	
Input Data 4	tRIP4	4 × tRCIP/7-0.4	4 × tRCIP/7	4 × tRCIP/7+0.4	nsec	
Input Data 5	tRIP3	5 × tRCIP/7-0.4	5 × tRCIP/7	5 × tRCIP/7+0.4	nsec	
Input Data 6	tRIP2	6 × tRCIP/7-0.4	6 × tRCIP/7	6 × tRCIP/7+0.4	nsec	

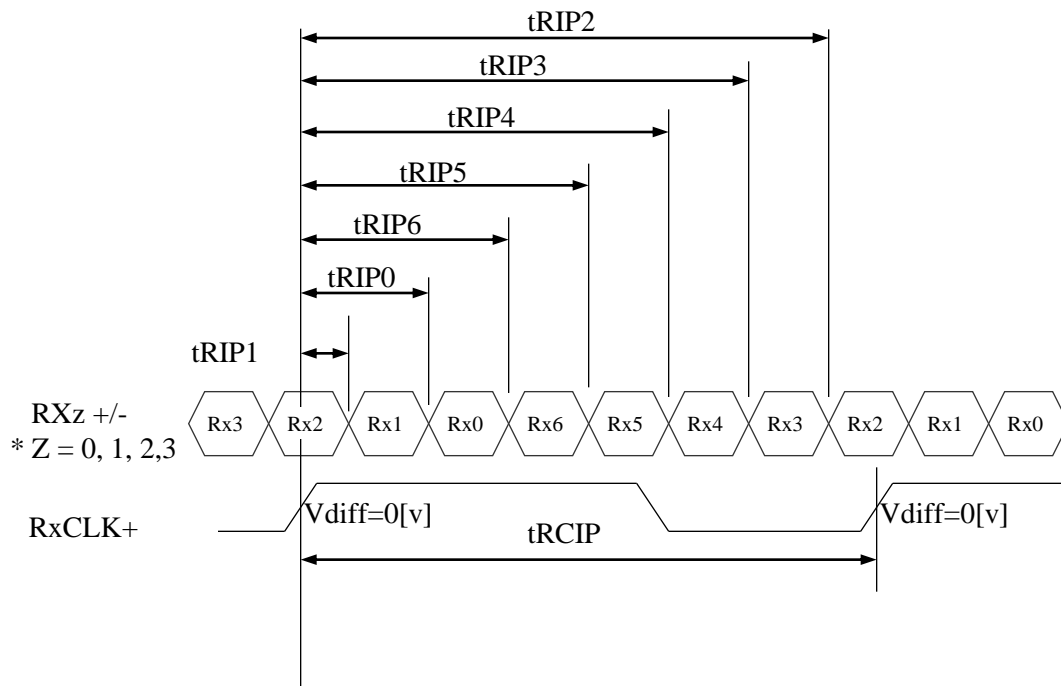

$$* V_{diff} = (RXz+) - (RXz-), \dots, (RXCLK+) - (RXCLK-)$$

7.0 SIGNAL TIMING WAVEFORMS OF INTERFACE SIGNAL

7.1 Sync Timing Waveforms

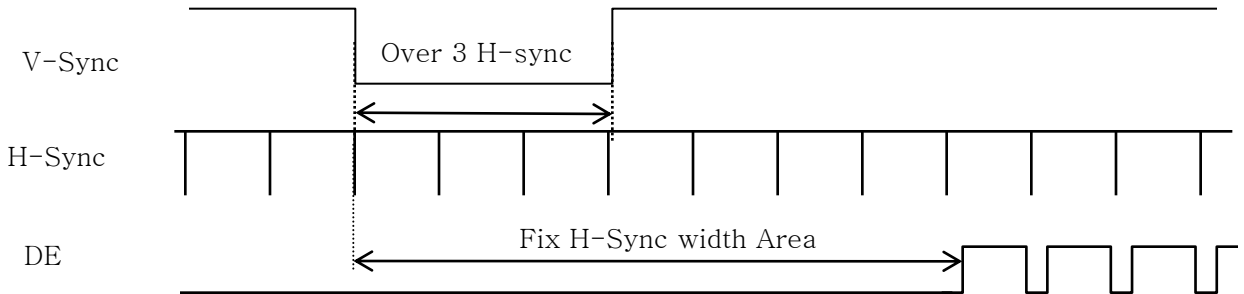

- 1) Need over 3 H-sync during V-Sync Low
- 2) Fix H-Sync width from V-Sync falling edge to first rising edge

7.2 Vertical Timing Waveforms

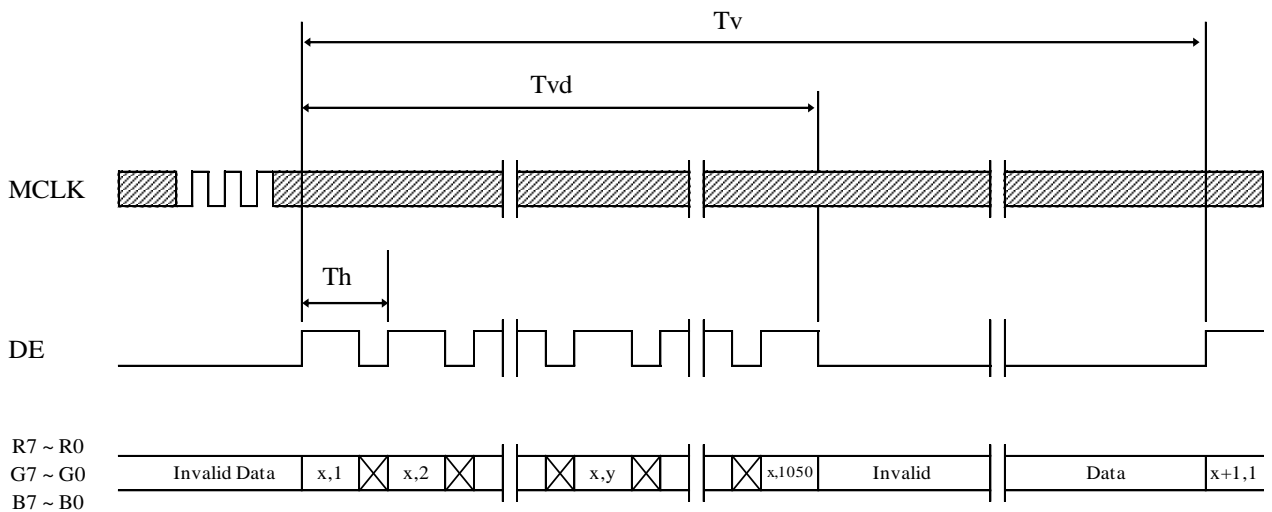

7.3 Horizontal Timing Waveforms

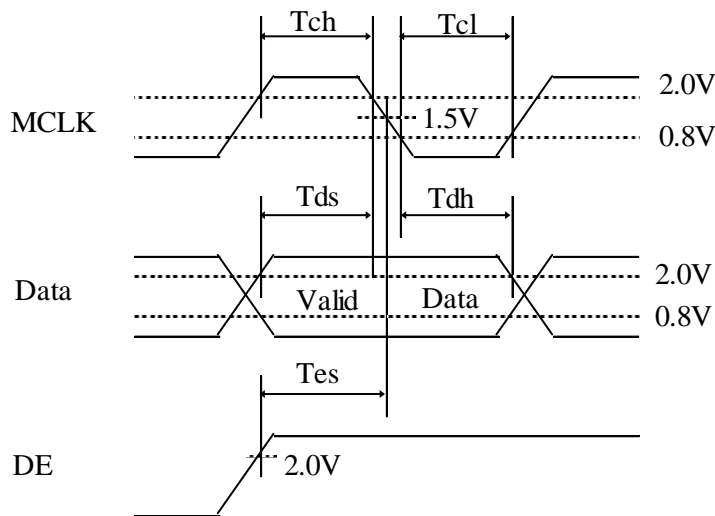
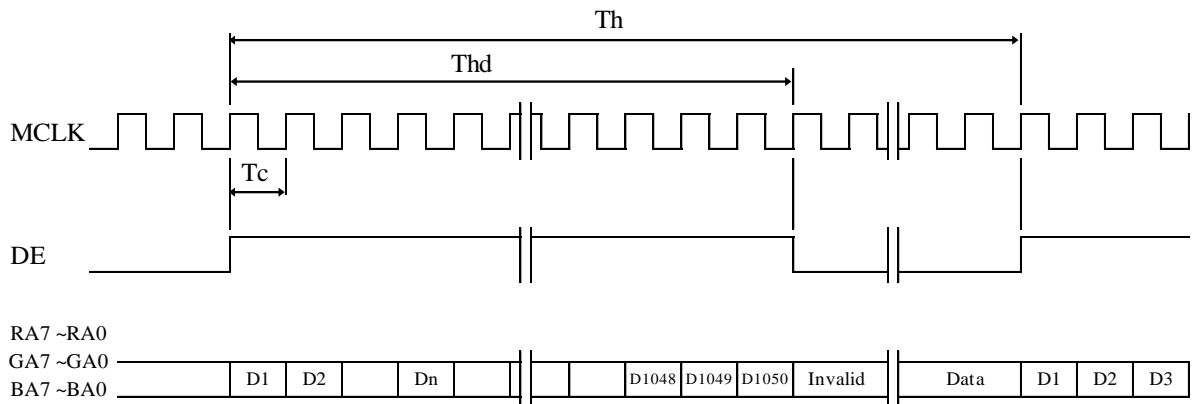

8.0 INPUT SIGNALS, BASIC DISPLAY COLORS & GRAY SCALE OF COLORS

Color & Gray Scale		RED DATA								GREEN DATA								BLUE DATA							
		R7	R6	R5	R4	R3	R2	R1	R0	G7	G6	G5	G4	G3	G2	G1	G0	B7	B6	B5	B4	B3	B2	B1	B0
Basic Colors	Black	0	0	0	0	0	0	0	0	0	0	0	0	0	0	0	0	0	0	0	0	0	0	0	0
	Blue	0	0	0	0	0	0	0	0	0	0	0	0	0	0	0	0	1	1	1	1	1	1	1	1
	Green	0	0	0	0	0	0	0	0	1	1	1	1	1	1	1	1	0	0	0	0	0	0	0	0
	Cyan	0	0	0	0	0	0	0	0	1	1	1	1	1	1	1	1	1	1	1	1	1	1	1	1
	Red	1	1	1	1	1	1	1	1	0	0	0	0	0	0	0	0	0	0	0	0	0	0	0	0
	Magenta	1	1	1	1	1	1	1	1	0	0	0	0	0	0	0	0	1	1	1	1	1	1	1	1
	Yellow	1	1	1	1	1	1	1	1	1	1	1	1	1	1	1	1	0	0	0	0	0	0	0	0
	White	1	1	1	1	1	1	1	1	1	1	1	1	1	1	1	1	1	1	1	1	1	1	1	1
Gray Scale of RED	Black	0	0	0	0	0	0	0	0	0	0	0	0	0	0	0	0	0	0	0	0	0	0	0	0
	△	0	0	0	0	0	0	0	1	0	0	0	0	0	0	0	0	0	0	0	0	0	0	0	0
	Darker	0	0	0	0	0	0	1	0	0	0	0	0	0	0	0	0	0	0	0	0	0	0	0	0
	△	↑								↑								↑							
	▽	↓								↓								↓							
	Brighter	1	1	1	1	1	1	0	1	0	0	0	0	0	0	0	0	0	0	0	0	0	0	0	0
	▽	1	1	1	1	1	1	1	0	0	0	0	0	0	0	0	0	0	0	0	0	0	0	0	0
	Red	1	1	1	1	1	1	1	1	0	0	0	0	0	0	0	0	0	0	0	0	0	0	0	0
Gray Scale of GREEN	Black	0	0	0	0	0	0	0	0	0	0	0	0	0	0	0	0	0	0	0	0	0	0	0	0
	△	0	0	0	0	0	0	0	0	0	0	0	0	0	0	0	1	0	0	0	0	0	0	0	0
	Darker	0	0	0	0	0	0	0	0	0	0	0	0	0	0	1	0	0	0	0	0	0	0	0	0
	△	↑								↑								↑							
	▽	↓								↓								↓							
	Brighter	0	0	0	0	0	0	0	0	1	1	1	1	1	1	0	1	0	0	0	0	0	0	0	0
	▽	0	0	0	0	0	0	0	0	1	1	1	1	1	1	1	0	0	0	0	0	0	0	0	0
	Green	0	0	0	0	0	0	0	0	1	1	1	1	1	1	1	1	0	0	0	0	0	0	0	0
Gray Scale of BLUE	Black	0	0	0	0	0	0	0	0	0	0	0	0	0	0	0	0	0	0	0	0	0	0	0	0
	△	0	0	0	0	0	0	0	0	0	0	0	0	0	0	0	0	0	0	0	0	0	0	0	1
	Darker	0	0	0	0	0	0	0	0	0	0	0	0	0	0	0	0	0	0	0	0	0	0	0	1
	△	↑								↑								↑							
	▽	↓								↓								↓							
	Brighter	0	0	0	0	0	0	0	0	0	0	0	0	0	0	0	0	1	1	1	1	1	1	0	1
	▽	0	0	0	0	0	0	0	0	0	0	0	0	0	0	0	0	1	1	1	1	1	1	1	0
	Blue	0	0	0	0	0	0	0	0	0	0	0	0	0	0	0	0	1	1	1	1	1	1	1	1
Gray Scale of WHITE	Black	0	0	0	0	0	0	0	0	0	0	0	0	0	0	0	0	0	0	0	0	0	0	0	0
	△	0	0	0	0	0	0	0	1	0	0	0	0	0	0	0	1	0	0	0	0	0	0	0	1
	Darker	0	0	0	0	0	0	1	0	0	0	0	0	0	0	1	0	0	0	0	0	0	0	1	0
	△	↑								↑								↑							
	▽	↓								↓								↓							
	Brighter	1	1	1	1	1	1	0	1	1	1	1	1	1	1	0	1	1	1	1	1	1	1	0	1
	▽	1	1	1	1	1	1	1	0	1	1	1	1	1	1	1	0	1	1	1	1	1	1	1	0
	White	1	1	1	1	1	1	1	1	1	1	1	1	1	1	1	1	1	1	1	1	1	1	1	1

9.0 POWER SEQUENCE

To prevent a latch-up or DC operation of the Open Cell, the power on/off sequence shall be as shown in below

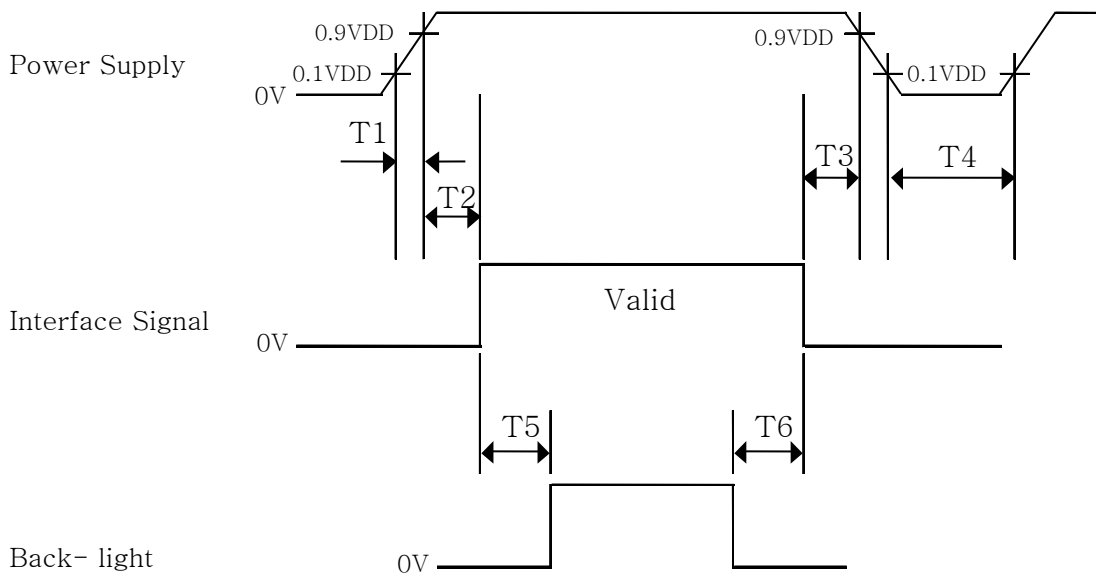

- $0.5 \text{ ms} \leq T1 \leq 10 \text{ ms}$
- $0 \leq T2 \leq 50 \text{ ms}$
- $0 \leq T3 \leq 50 \text{ ms}$
- $1 \text{ sec} \leq T4$
- $200 \text{ ms} \leq T5$
- $200 \text{ ms} \leq T6$

Notes:

1. When the power supply VDD is 0V, keep the level of input signals on the low or keep high impedance.
2. Do not keep the interface signal high impedance when power is on.
3. Back Light must be turn on after power for logic and interface signal are valid.

10.0 MECHANICAL CHARACTERISTICS

10.1 Dimensional Requirements

FIGURE 6 (located in Appendix) shows mechanical outlines for the open cell HM185WX3-300. Other parameters are shown in Table 5.

<Table 5. Dimensional Parameters>

Parameter	Specification	Unit
Weight	500 (max.)	gram
Active area	409.8(H) × 230.4(V)	mm
Pixel pitch	0.3(H) × 0.3(V)	mm
Number of pixels	1366(H) × 768(V) (1 pixel = R + G + B dots)	pixels

10.2 Anti-Glare and Polarizer Hardness.

The surface of the LCD has an anti-glare coating to minimize reflection and a coating to reduce scratching.

11.0 RELIABILITY TEST

The Reliability test items and its conditions are shown in below.

<Table 6. Reliability Test Parameters >

No	Test Items	Conditions		Note 1
1	High temperature storage test	Ta = 60 °C, 240 hrs		
2	Low temperature storage test	Ta = -20 °C, 240 hrs		
3	High temperature & high humidity (operation test)	Ta = 50 °C, 80%RH, 240hrs		
4	High temperature operation test	Ta = 50 °C, 240hrs		
5	Low temperature operation test	Ta = 0 °C, 240hrs		
6	Thermal shock	Ta = -20 °C ↔ 60 °C (0.5 hr), 100 cycle		
7	Electro-static discharge test (non-operating)	Air: 150 pF, 330Ω, 15 KV		
		Contact: 150 pF, 330Ω, 8 KV		
8	Vibration test (non-operating)	Frequency	10 ~ 300 Hz, Sweep rate 30 min	
		Gravity / AMP	1.5 G	
		Period	+X, +Y, +Z 30 min	
9	Packing Vibration Test	1.47Grms, 1~200Hz, Random		
		±X, ±Y, ±Z per 1hr		
10	Drop Test	1Angle,3Edge,6Face		
		Height: JIS-Z-0200 Level 1		
				Note 2

Notes:

1. The tests are done with LCD modules. (Use BOEHF BLU)
2. The test is done with a package (20pcs open cell / 1 Box) shown in section 14.

12.0 HANDLING & CAUTIONS

- (1) Cautions when taking out the open cell
 - Pick the pouch only, when taking out open cell from a shipping package.
- (2) Cautions for handling the open cell
 - As the electrostatic discharges may break the LCD open cell, handle the LCD open cell with care. Peel a protection sheet off from the LCD panel surface as slowly as possible.
 - As the LCD panel is made from fragile glass material, impulse and pressure to the LCD module should be avoided.
 - As the surface of the polarizer is very soft and easily scratched, use a soft dry cloth without chemicals for cleaning.
 - Do not pull the interface connector in or out while the LCD open cell is operating.
 - Handle connectors and cables with care.
- (3) Cautions for the operation
 - When the open cell is operating, do not lose CLK, ENAB signals. If any one of these signals is lost, the LCD panel would be damaged.
 - Obey the supply voltage sequence. If wrong sequence is applied, the open cell would be damaged.
- (4) Cautions for the atmosphere
 - Dew drop atmosphere should be avoided.
 - Do not store and/or operate the LCD open cell in a high temperature and/or humidity atmosphere. Storage in an electro-conductive polymer packing pouch and under relatively low temperature atmosphere is recommended.
- (5) Cautions for the open cell characteristics
 - Do not apply fixed pattern data signal to the LCD open cell at product aging.
 - Applying fixed pattern for a long time may cause image sticking.
- (6) Other cautions
 - Do not re-adjust variable resistor or switch etc.
 - When returning the open cell for repair or etc., Please pack the open cell not to be broken. We recommend to use the original shipping packages.

13.0 PRODUCT SERIAL NUMBER



Label Size: 80mm (L) x 40 mm (W)

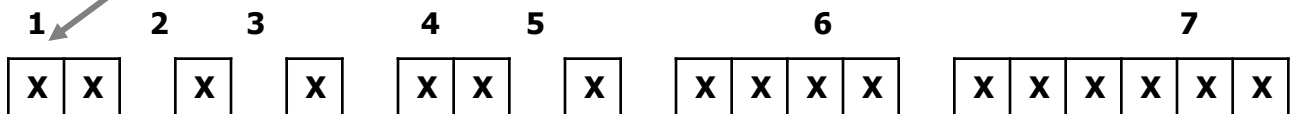

Digit	1	2	3	4	5	6	7	8	9	10	11	12	13	14	15	16	17
Code	S	L	S	3	0	9	3	5	9	4	2	0	0	0	1	D	B
Description	Model Code /GBN		Grade	Line	Year		Month	Model Extension Code (Last 4 Digits Of FGCOD)				Serial No Hex-Decimal 00000-FFFFFF					

Line	
Code	Description
3	BOEHF

Month	
Code	Description
1	1月
2	2月
...	...
A	10月
B	11月
C	12月

14.0 Packing

14.1 Packing Order

- First put one PE cushion in the tray

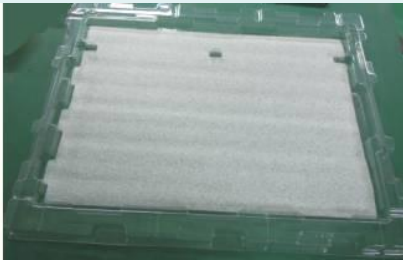

- Then put one open cell on PE cushion

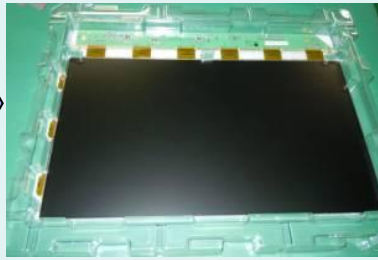

- One PE cushion again, , Total ly 4 pcs open cell and 5 pcs PE cushion in one tray, Finally another 4 mm epe on the top.

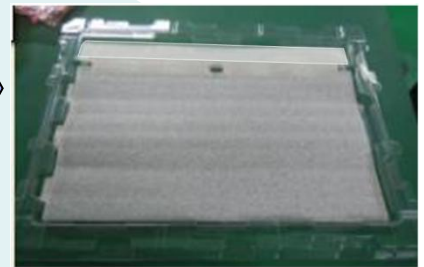

- One pallet contains 12 boxes, that is 240 pcs open cell (outbox not shown);

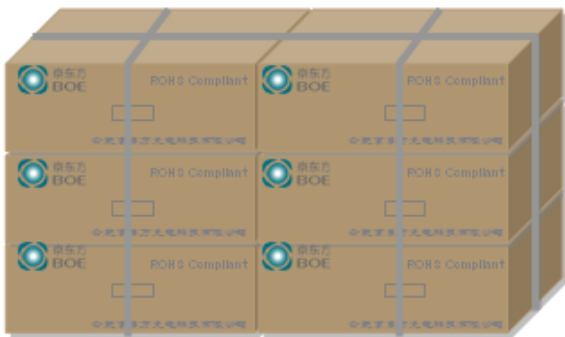

- Totally 6 tray (one empty tray on the top, 20pcs open cell) in PE bag, PE bag sealing by tape;



- Tape sealing (20 pcs open cell in one box)



- Top cover



Attention:

1. Open cell packing in clean room;
2. Operators should take open cell carefully, especially COF;
3. 20pcs open cell must be filled in one paper box;
4. Packing flow should be strictly followed;
5. Open cell is fragile materials, please pay attention both in packing and transportation;

14.2 Packing Note

- Box Dimension : 440mm(W) × 550mm(L) × 220mm(H)
- Package Quantity in one Box : 20pcs

14.3 Box label

- Label Size : 108 mm (L) × 56 mm (W)
- Contents
Open cell : HM185WX3-300
Q`ty : 20
Serial No. : Box Serial No. See following picture for detail description.
Date : Packing Date
FG Code : FG Code of Product

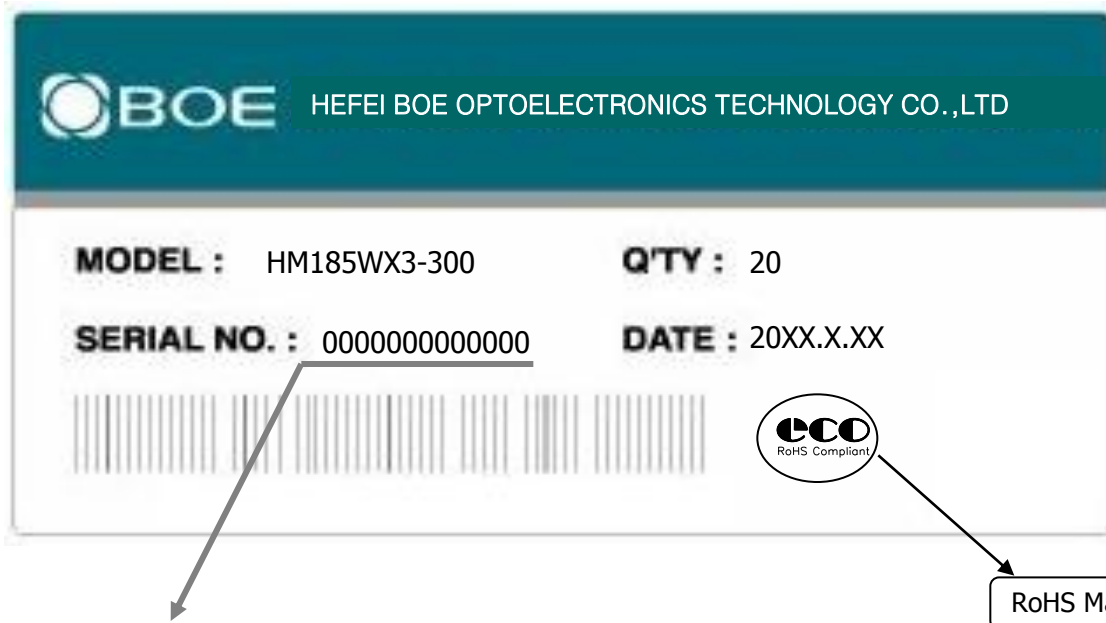

Digit Code	1	2	3	4	5	6	7	8	9	10	11	12	13
Code	S	L	S	3	0	9	3	D	0	0	0	6	8
Description	Products GBN		Grade	Line	Year		Month	Revision Code					

15.0 APPENDIX

Figure 1. Measurement Set Up

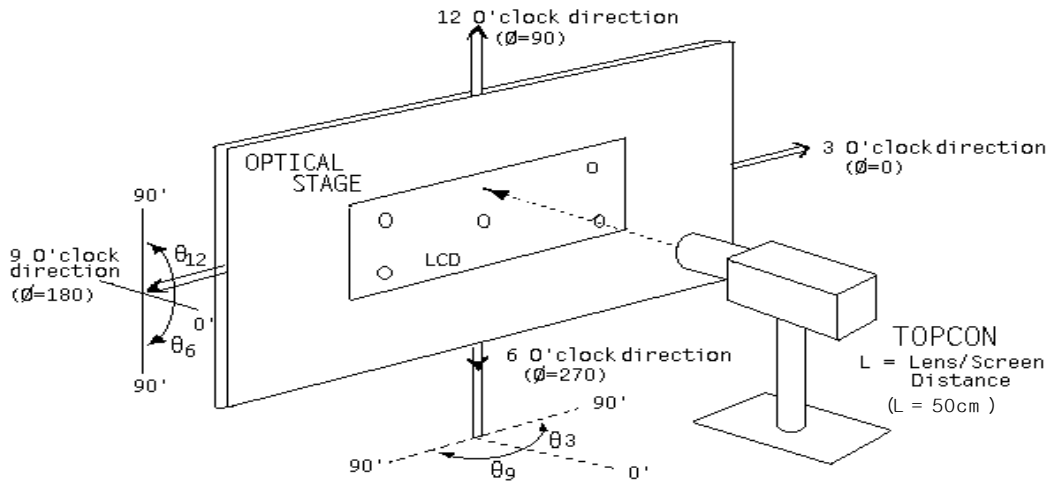

Figure 2. White Luminance and Uniformity Measurement Locations (9 points)

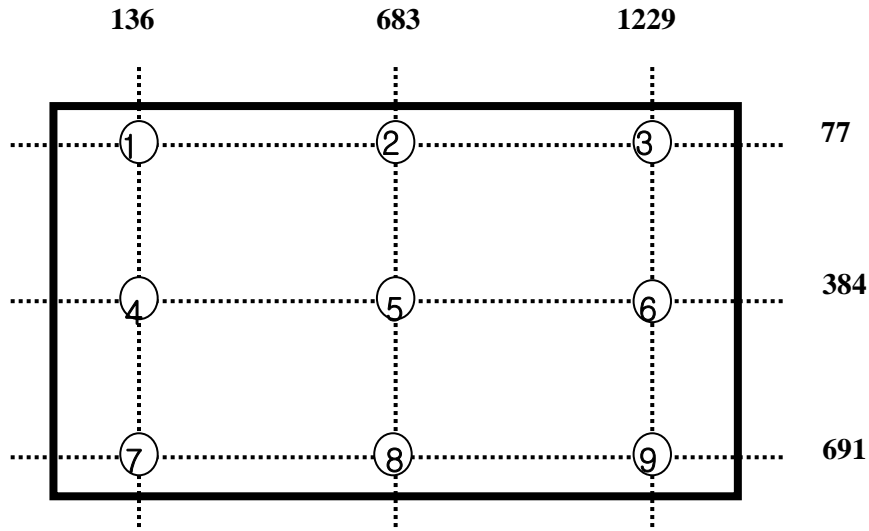
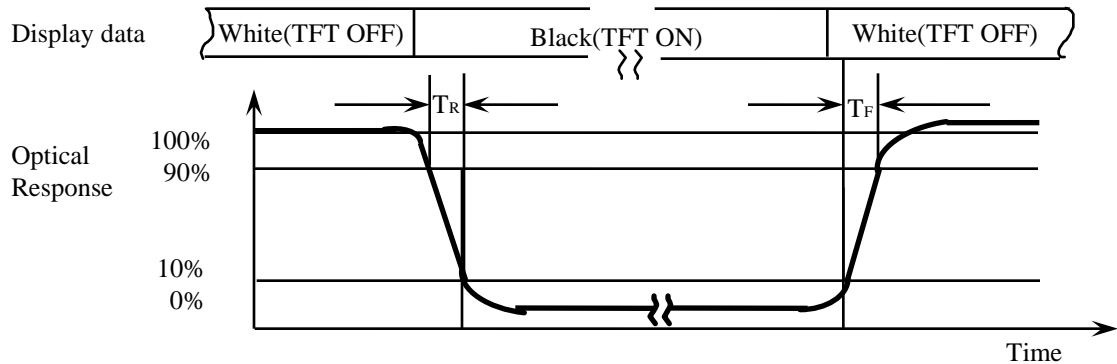
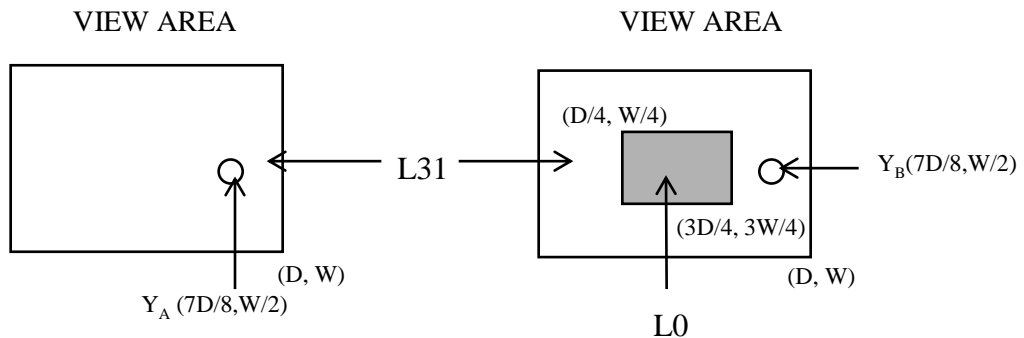

Figure 3. Response Time Testing

Figure 4. Cross Modulation Test Description

$$\text{Cross-Talk (\%)} = \left| \frac{Y_B - Y_A}{Y_A} \right| \times 100$$

Where: Y_A = Initial luminance of measured area (cd/m^2)

Y_B = Subsequent luminance of measured area (cd/m^2)

The location measured will be exactly the same in both patterns

Figure 5. Open Cell Outline Dimensions

