

描述 / Descriptions

SOT-23 塑封封装 N 道 MOS 场效应管。N- CHANNEL MOSFET in a SOT-23 Plastic Package.

特征 / Features

低导通电阻,开关速度快,低电压驱动,简化驱动电路和简便平面。

Low on-resistance, fast switching speed, low voltage drive, easily designed drive circuits, easy to parallel.

用途 / Applications

触摸屏, 交换开关。

Interfacing, switching.

内部等效电路 / Equivalent Circuit

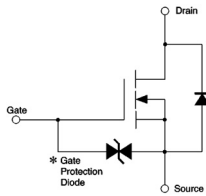

引脚排列 / Pinning



PIN1 : S

PIN 2 : G

PIN 3 : D

印章代码 / Marking

Marking	KL
---------	----

极限参数 / Absolute Maximum Ratings(Ta=25°C)

参数 Parameter	符号 Symbol	数值 Rating	单位 Unit
Drain-Source Voltage	V_{DSS}	30	V
Gate-Source Voltage	V_{GSS}	±20	V
Drain Current – Continuous	I_D	100	mA
Drain Current- Pulsed	I_{DP}^{*1}	200	mA
Reverse Drain Current – Continuous	I_{DR}	100	mA
Reverse Drain Current –Pulsed	I_{DRP}^{*1}	200	mA
Total Power Dissipation	P_D^{*2}	250	mW
Channel Temperature	T_{ch}	150	V
Storage Temperature Range	T_{stg}	-55~150	°C

*1: $P_w \leq 10\mu s$, Duty cycle ≤ 50%

*2:With each pin mounted on the recommended lands

电性能参数 / Electrical Characteristics(Ta=25°C)

参数 Parameter	符号 Symbol	测试条件 Test Conditions	最小值 Min	典型值 Typ	最大值 Max	单位 Unit
Drain–Source Breakdown Voltage	$V_{(BR)DSS}$	$V_{GS}=0V$ $I_D=10\mu A$	30			V
Gate Threshold Voltage	$V_{GS(th)}$	$V_{DS}=3.0V$ $I_D=100\mu A$	0.8		1.5	V
Static Drain–Source On–Resistance	$R_{DS(on)1}$	$V_{GS}=4.0V$ $I_D=10mA$		5.0	8.0	Ω
	$R_{DS(on)2}$	$V_{0047S}=2.5V$ $I_D=1.0mA$		7.0	13	
Zero Gate Voltage Drain Current	I_{DSS}	$V_{DS}=30V$ $V_{GS}=0V$			1.0	μA
Gate–Body Leakage.	I_{GSS}	$V_{GS}=\pm 20V$ $V_{DS}=0V$			±1	μA
Forward Transconductance	g_{FS}	$V_{DS}=3V$ $I_D=10mA$	20			mS
Input Capacitance	C_{iss}	$V_{DS}=5.0V$ $V_{GS}=0V$ $f=1.0MHz$		13		pF
Output Capacitance	C_{oss}			9.0		
Reverse Transfer Capacitance	C_{rss}			4.0		
Turn–On Delay Time	$t_{d(on)}$	$I_D=10mA$ $V_{DD}\approx 5.0V$ $V_{GS}=5.0V$ $R_L=500\Omega$ $R_{GS}=10\Omega$		15		ns
Turn–On Rise Time	t_r			35		
Turn–Off Delay Time	$t_{d(off)}$			80		
Turn–Off Fall Time	t_f			80		

电参数曲线图 / Electrical Characteristic Curve

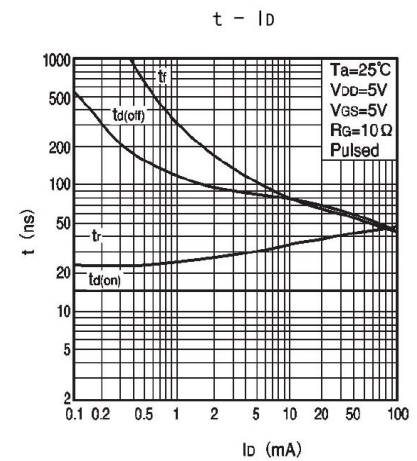
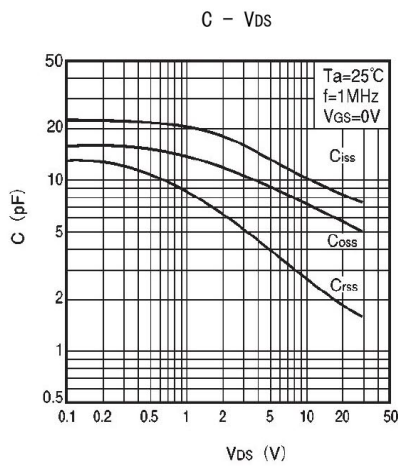
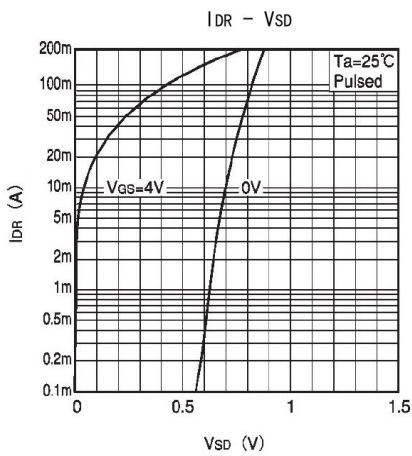
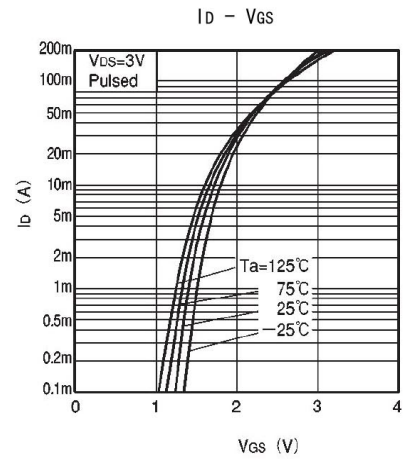
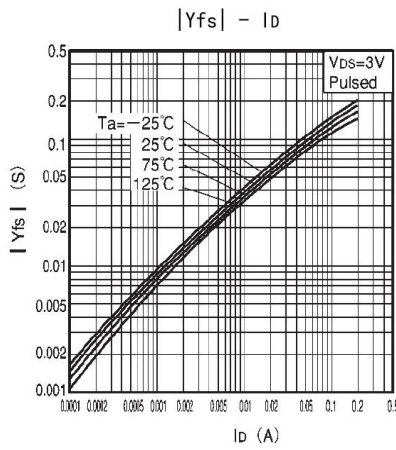
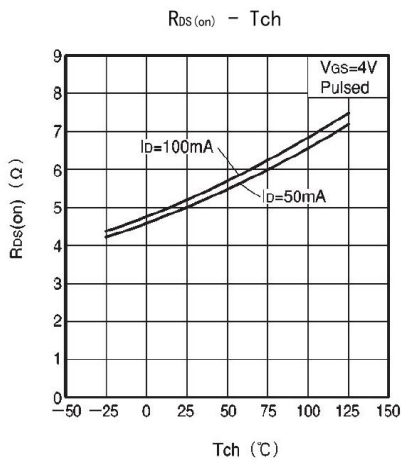
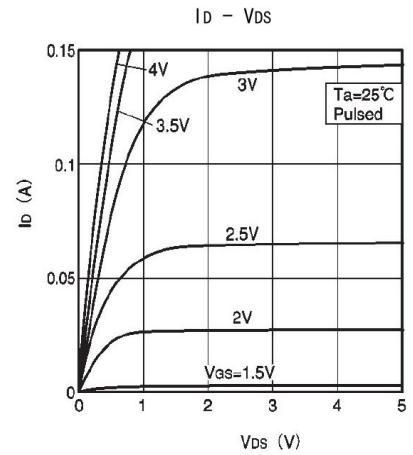
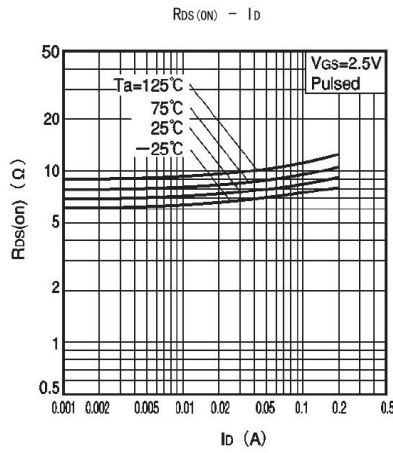
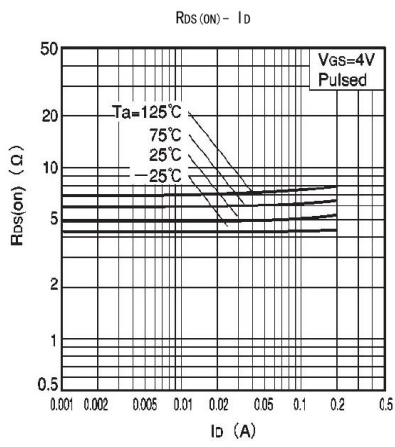

外形尺寸图 / Package Dimensions

SOT-23

单位: mm

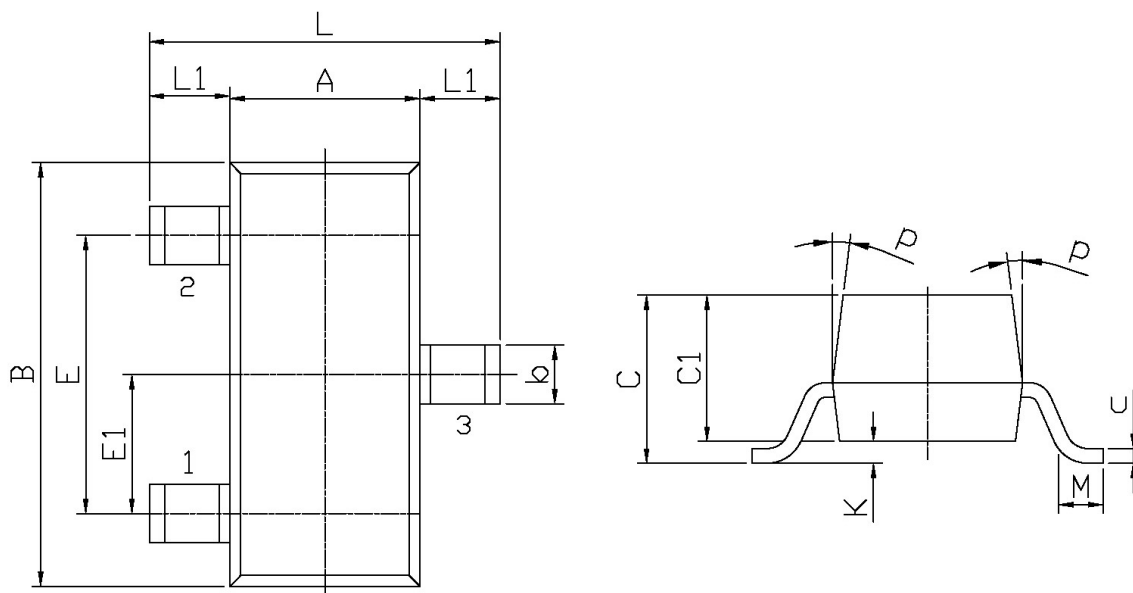

Symbol	Dimensions In Millimeters		Symbol	Dimensions In Millimeters	
	Min	Max		Min	Max
L	2.2	2.7	C	1.30Max	
L1	0.45	0.65	C1	0.90	1.20
A	1.15	1.50	c	0.05	0.20
B	2.70	3.10	K	0	0.10
E	1.70	2.10	M	0.20MIN	
E1	0.85	1.05	P	7°	
b	0.35	0.55			

印章说明 / Marking Instructions

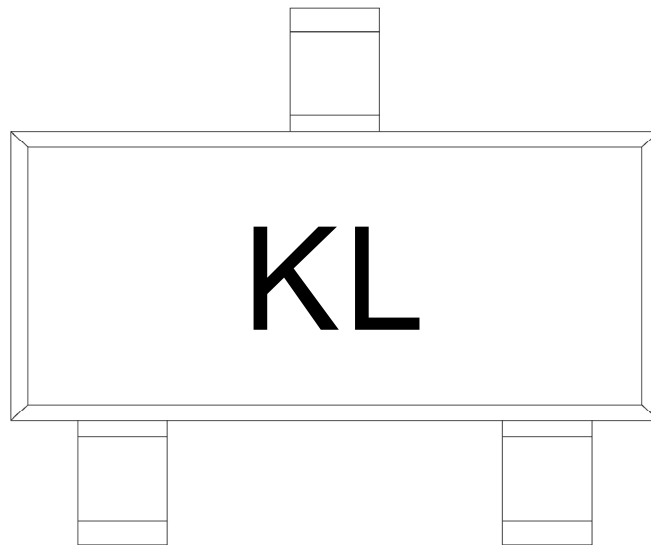

说明：

KL: 为封装型号

Note:

KL : Package Type

回流焊温度曲线图(无铅) / Temperature Profile for IR Reflow Soldering(Pb-Free)



说明：

- 1、预热温度 25~150°C，时间 60~90sec;
- 2、峰值温度 245±5°C，时间持续为 5±0.5sec;
- 3、焊接制程冷却速度为 2~10°C/sec.

Note:

- 1.Preheating:25~150°C, Time:60~90sec.
- 2.Peak Temp.:245±5°C, Duration:5±0.5sec.
3. Cooling Speed: 2~10°C/sec.

耐焊接热试验条件 / Resistance to Soldering Heat Test Conditions

温度：260±5°C 时间：10±1 sec. Temp.:260±5°C Time:10±1 sec

包装规格 / Packaging SPEC.

卷盘包装 / REEL

Package Type 封装形式	Units 包装数量					Dimension 包装尺寸 (unit: mm ³)		
	Units/Reel 只/卷盘	Reels/Inner Box 卷盘/盒	Units/Inner Box 只/盒	Inner Boxes/Outer Box 盒/箱	Units/Outer Box 只/箱	Reel	Inner Box 盒	Outer Box 箱
SOT-23	3,000	10	30,000	8	240,000	7" ×8	180×120×180	385×257×392

使用说明 / Notices

