

三端可调节输出正电压稳压器

HM317是可调节3-端正电压稳压器，在输出电压范围为1.2伏到37伏时能够提供超过1.5安的电流。此稳压器非常易于使用，只需要两个外部电阻来设置输出电压。此外还使用内部限流、热关断和安全工作区补偿使之基本能防止烧断保险丝。

HM317服务于多种应用场合，包括局部稳压、卡上稳压。该器件还可以用来制做一种可编程的输出稳压器，或者，通过在调整点和输出之间接一个固定电阻，HM317可用作一种精密稳流器。

- 输出电流超过1.5安
- 输出在1.2伏和37伏之间可调节
- 内部热过载保护
- 不随温度变化的内部短路电流限制
- 输出晶体管安全工作区补偿
- 对高压应用孚空工作
- 表面贴装D²PAK形式,和标准3引脚晶体管封装
- 避免置备多种固定电压

标准应用

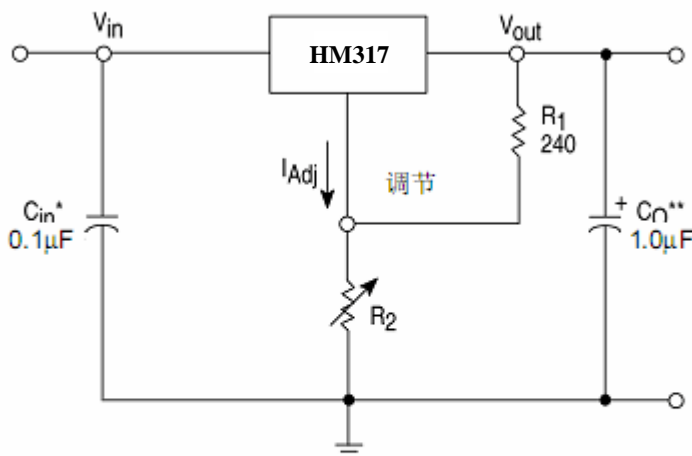

*当稳压器离电源滤波器有一定距离时 C_{in} 是必需的

** C_o 对稳定性而言不必要;但改进瞬态响应

$$V_{out} = 1.25V \left(1 + \frac{R_2}{R_1} \right) + I_{Adj} R_2$$

因为 I_{Adj} 控制在小于 $100\mu A$, 这一项的误差在多数应用中可忽略

T 后缀
塑料封装
外壳 221A

散热器表面连接到
引脚 2

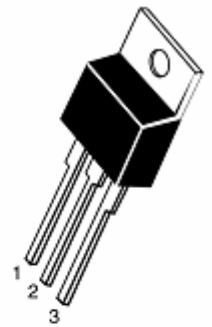

管脚: 1.调节
2.Vout
3.Vin

D2T 后缀
塑料封装
外壳 936
(D²PAK)

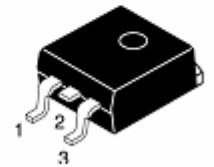

散热器表面(在外形图中表示为端子 4)
连接到管脚 2 上

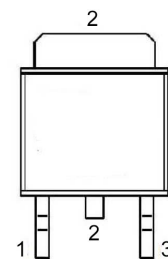

TO-252-2L

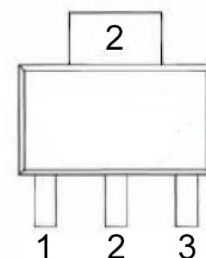

GCH&&

最大额定值

额定值	符号	值	单位
输入输出电压差	$V_I - V_O$	40	Vdc
功耗			
外壳 221A			
$T_A = +25^\circ\text{C}$	P_D	内部限制	W
结至环境热阻	θ_{JA}	65	$^\circ\text{C/W}$
结至外壳热阻	θ_{JC}	5.0	$^\circ\text{C/W}$
外壳 936(D ² PAK)			
$T_A = +25^\circ\text{C}$	P_D	内部限制	W
结至环境热阻	θ_{JA}	70	$^\circ\text{C/W}$
结至外壳热阻	θ_{JC}	5.0	$^\circ\text{C/W}$
工作结温范围	T_J	0 至 +125	$^\circ\text{C}$
保存温度范围	T_{stg}	-65 至 +150	$^\circ\text{C}$

ELECTRICAL CHARACTERISTICS ($V_I - V_O = 5\text{ V}$, $I_O = 500\text{ mA}$, $I_{MAX} = 1.5\text{ A}$ and $P_{MAX} = 20\text{ W}$, unless otherwise specified)

Symbol	Parameter	Test Conditions	LM317			Unit	
			Min.	Typ.	Max.		
ΔV_O	Line Regulation	$V_I - V_O = 3\text{ to }40\text{ V}$ $T_J = 25^\circ\text{C}$		0.01	0.04	%/V	
				0.02	0.07	%/V	
ΔV_O	Load Regulation	$V_O \leq 5\text{ V}$ $I_O = 10\text{ mA to }I_{MAX}$	$T_J = 25^\circ\text{C}$	5	25	mV	
				20	70	mV	
		$V_O \geq 5\text{ V}$ $I_O = 10\text{ mA to }I_{MAX}$	$T_J = 25^\circ\text{C}$	0.1	0.5	%	
				0.3	1.5	%	
I_{ADJ}	Adjustment Pin Current		50	100	μA		
ΔI_{ADJ}	Adjustment Pin Current	$V_I - V_O = 2.5\text{ to }40\text{ V}$ $I_O = 10\text{ mA to }I_{MAX}$		0.2	5	μA	
V_{REF}	Reference Voltage (between pin 3 and pin 1)	$V_I - V_O = 2.5\text{ to }40\text{ V}$ $I_O = 10\text{ mA to }I_{MAX}$ $P_D \leq P_{MAX}$	1.2	1.25	1.3	V	
$\frac{\Delta V_O}{V_O}$	Output Voltage Temperature Stability			1		%	
$I_{O(min)}$	Minimum Load Current	$V_I - V_O = 40\text{ V}$		3.5	10	mA	
$I_{O(max)}$	Maximum Load Current	$V_I - V_O \leq 15\text{ V}$ $P_D < P_{MAX}$	1.5	2.2		A	
		$V_I - V_O = 40\text{ V}$ $P_D < P_{MAX}$ $T_J = 25^\circ\text{C}$		0.4		A	
e_N	Output Noise Voltage (percentage of V_O)	$B = 10\text{ Hz to }10\text{ KHz}$ $T_J = 25^\circ\text{C}$		0.003		%	
SVR	Supply Voltage Rejection (*)	$T_J = 25^\circ\text{C}$ $f = 120\text{ Hz}$	$C_{ADJ} = 0$		65		dB
			$C_{ADJ} = 10\mu\text{F}$	66	80		dB

典型原理图



图 1.电源调整率和 ΔI_{Adj} /电源测试电路



图 2.负载调整率和 ΔI_{Adj} /负载测试电路

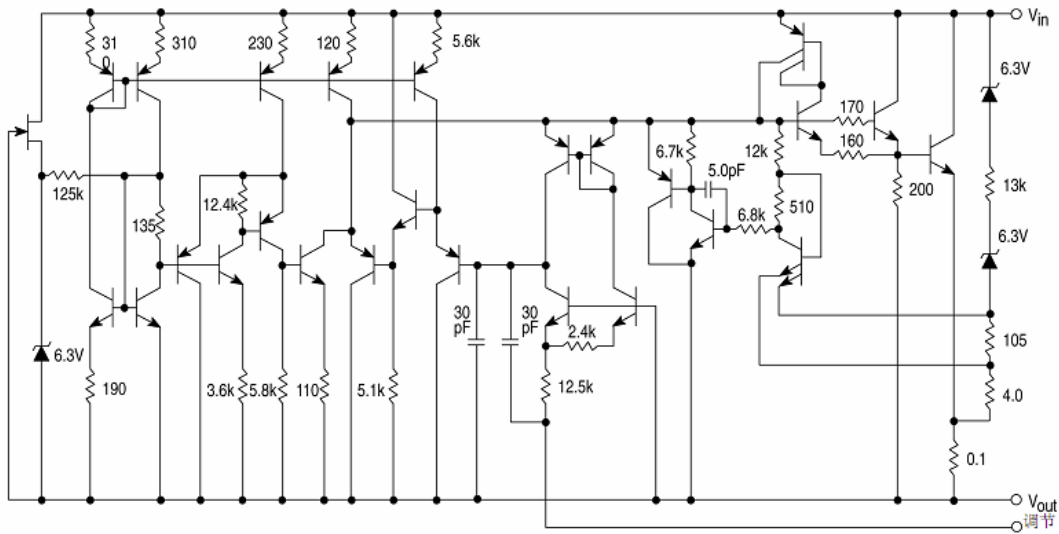

图 3. 标准测试电路

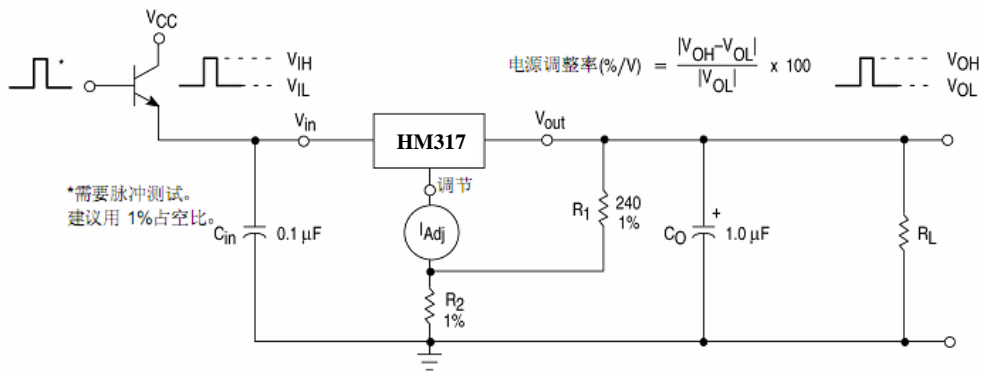

图 4. 纹波抑制测试电路

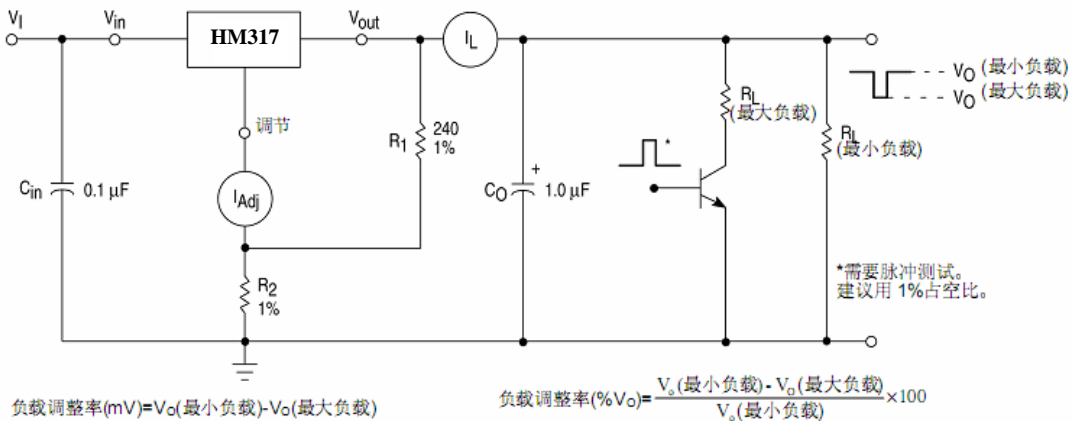

TO-220-3L PACKAGE OUTLINE DIMENSIONS

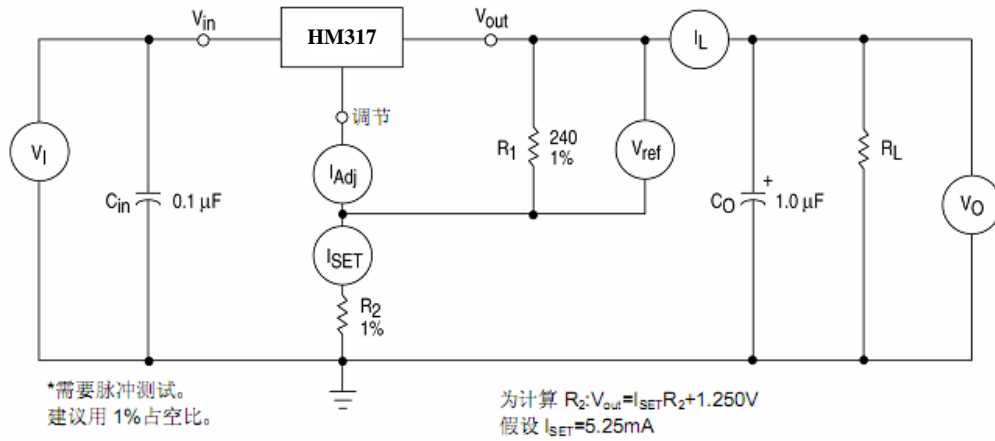
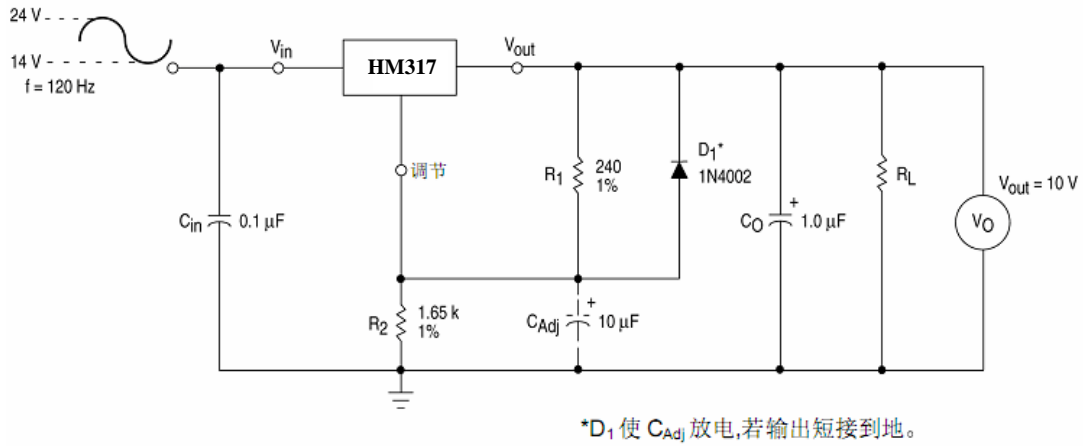
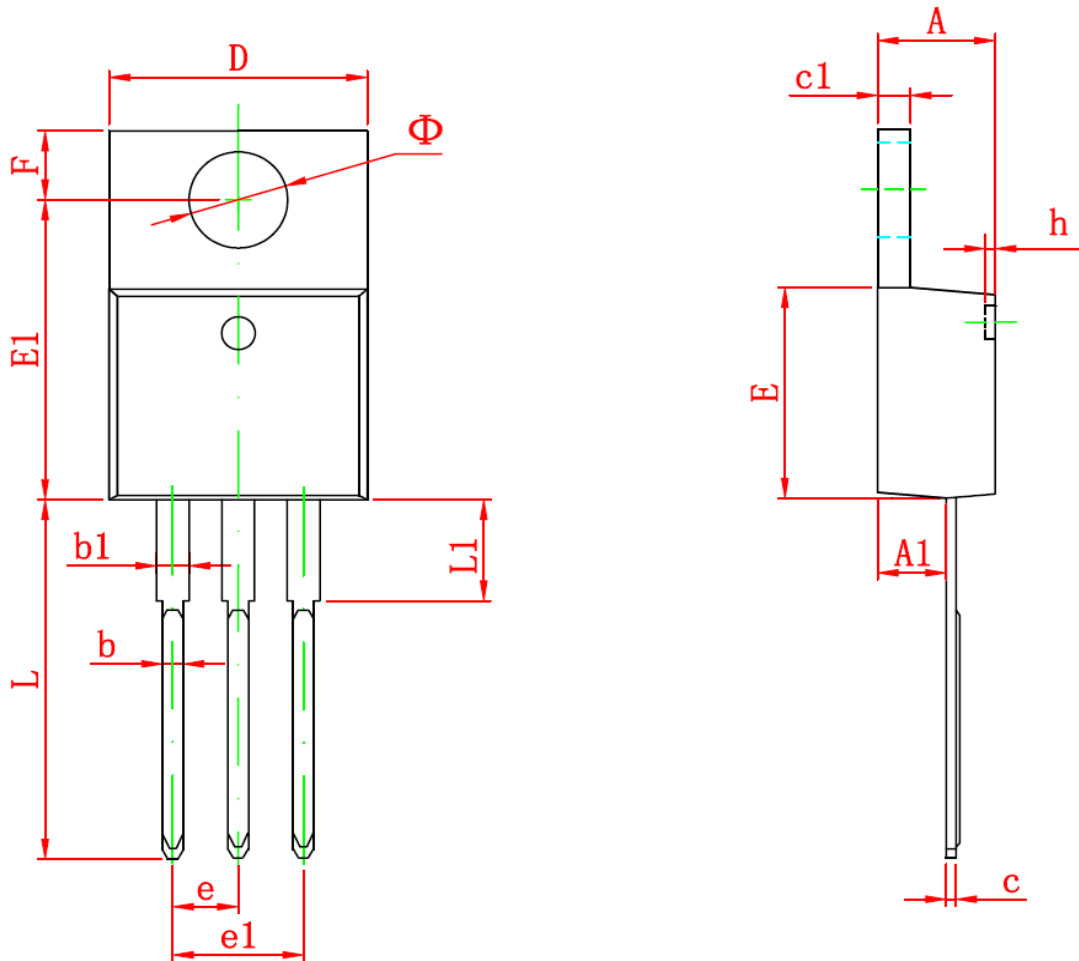

Symbol	Dimensions In Millimeters		Dimensions In Inches	
	Min	Max	Min	Max
A	4.470	4.670	0.176	0.184
A1	2.520	2.820	0.099	0.111
b	0.710	0.910	0.028	0.036
b1	1.170	1.370	0.046	0.054
c	0.310	0.530	0.012	0.021
c1	1.170	1.370	0.046	0.054
D	10.010	10.310	0.394	0.406
E	8.500	8.900	0.335	0.350
E1	12.060	12.460	0.475	0.491
e	2.540 TYP		0.100 TYP	
e1	4.980	5.180	0.196	0.204
F	2.590	2.890	0.102	0.114
h	0.000	0.300	0.000	0.012
L	13.400	13.800	0.528	0.543
L1	3.560	3.960	0.140	0.156
Φ	3.735	3.935	0.147	0.155

TO-263-2L PACKAGE OUTLINE DIMENSIONS

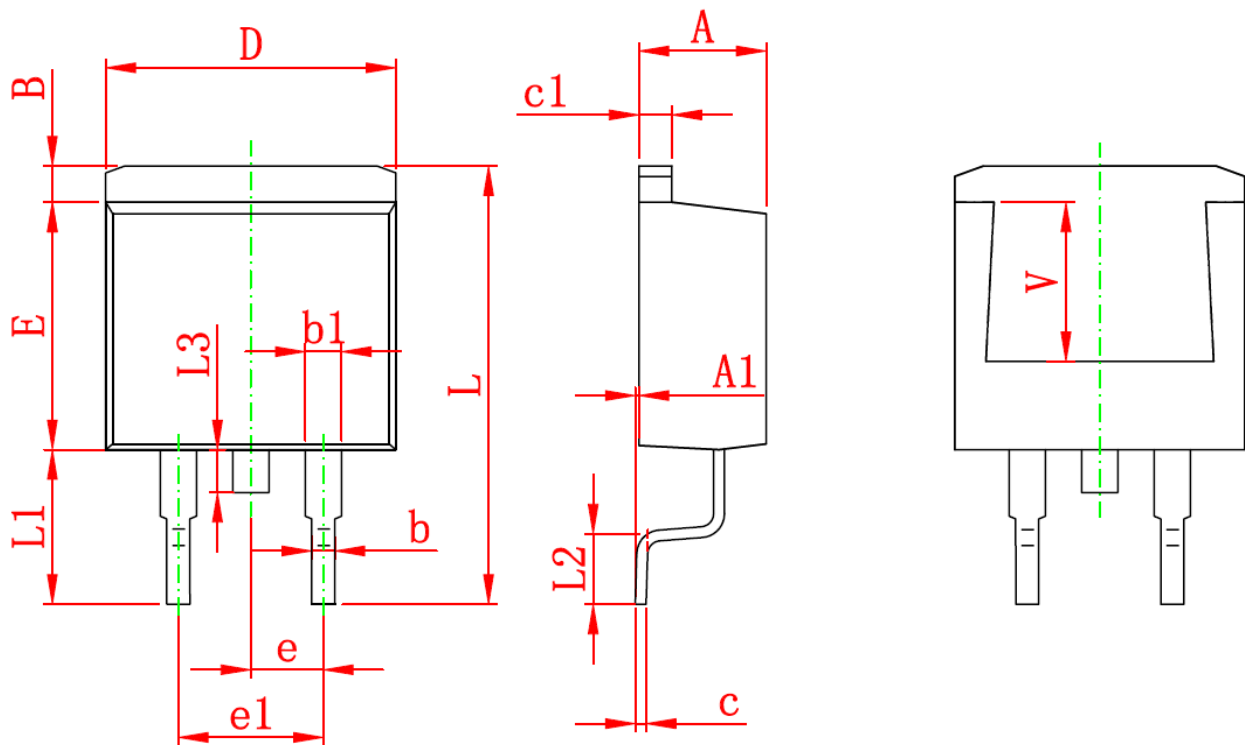

Symbol	Dimensions In Millimeters		Dimensions In Inches	
	Min	Max	Min	Max
A	4.470	4.670	0.176	0.184
A1	0.000	0.150	0.000	0.006
B	1.170	1.370	0.046	0.054
b	0.710	0.910	0.028	0.036
b1	1.170	1.370	0.046	0.054
c	0.310	0.530	0.012	0.021
c1	1.170	1.370	0.046	0.054
D	10.010	10.310	0.394	0.406
E	8.500	8.900	0.335	0.350
e	2.540 TYP		0.100 TYP	
e1	4.980	5.180	0.196	0.204
L	15.050	15.450	0.593	0.608
L1	5.080	5.480	0.200	0.216
L2	2.340	2.740	0.092	0.108
L3	1.300	1.700	0.051	0.067
V	5.600 REF		0.220 REF	

TO-252-2L PACKAGE OUTLINE DIMENSIONS

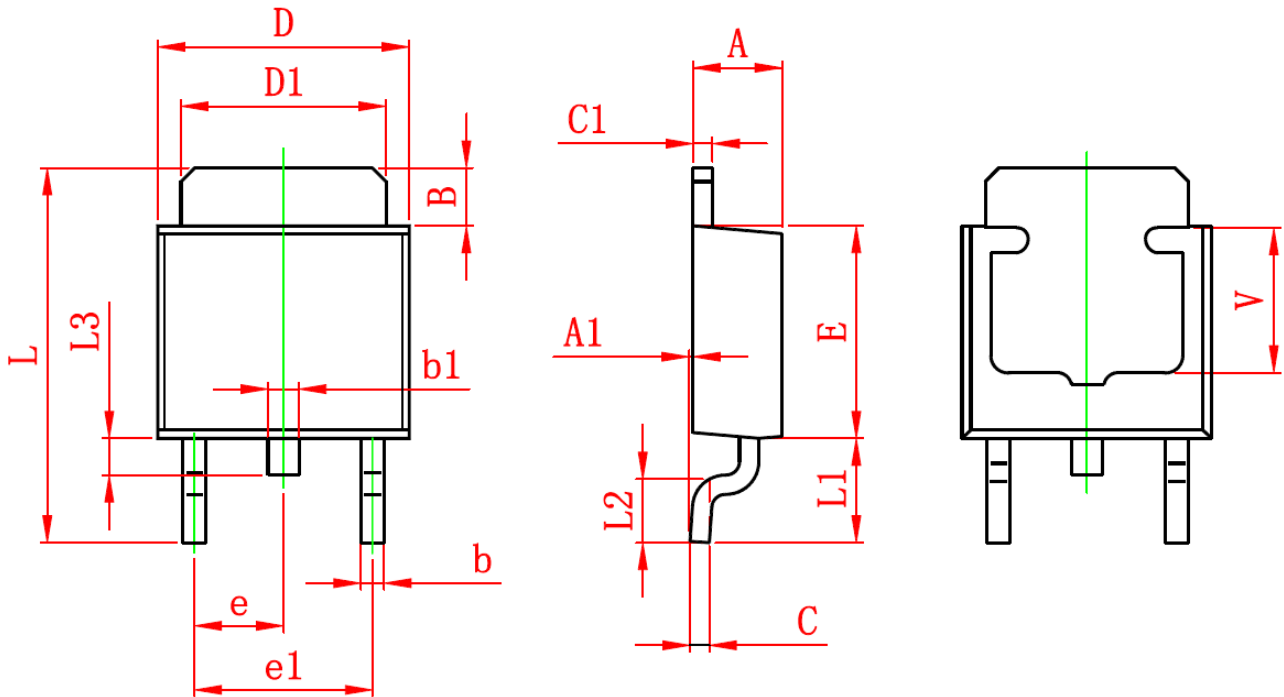

Symbol	Dimensions In Millimeters		Dimensions In Inches	
	Min.	Max.	Min.	Max.
A	2.200	2.400	0.087	0.094
A1	0.000	0.127	0.000	0.005
B	1.350	1.650	0.053	0.065
b	0.500	0.700	0.020	0.028
b1	0.700	0.900	0.028	0.035
c	0.430	0.580	0.017	0.023
c1	0.430	0.580	0.017	0.023
D	6.350	6.650	0.250	0.262
D1	5.200	5.400	0.205	0.213
E	5.400	5.700	0.213	0.224
e	2.300 TYP.		0.091 TYP.	
e1	4.500	4.700	0.177	0.185
L	9.500	9.900	0.374	0.390
L1	2.550	2.900	0.100	0.114
L2	1.400	1.780	0.055	0.070
L3	0.600	0.900	0.024	0.035
V	3.800 REF.		0.150 REF.	

Package Information:

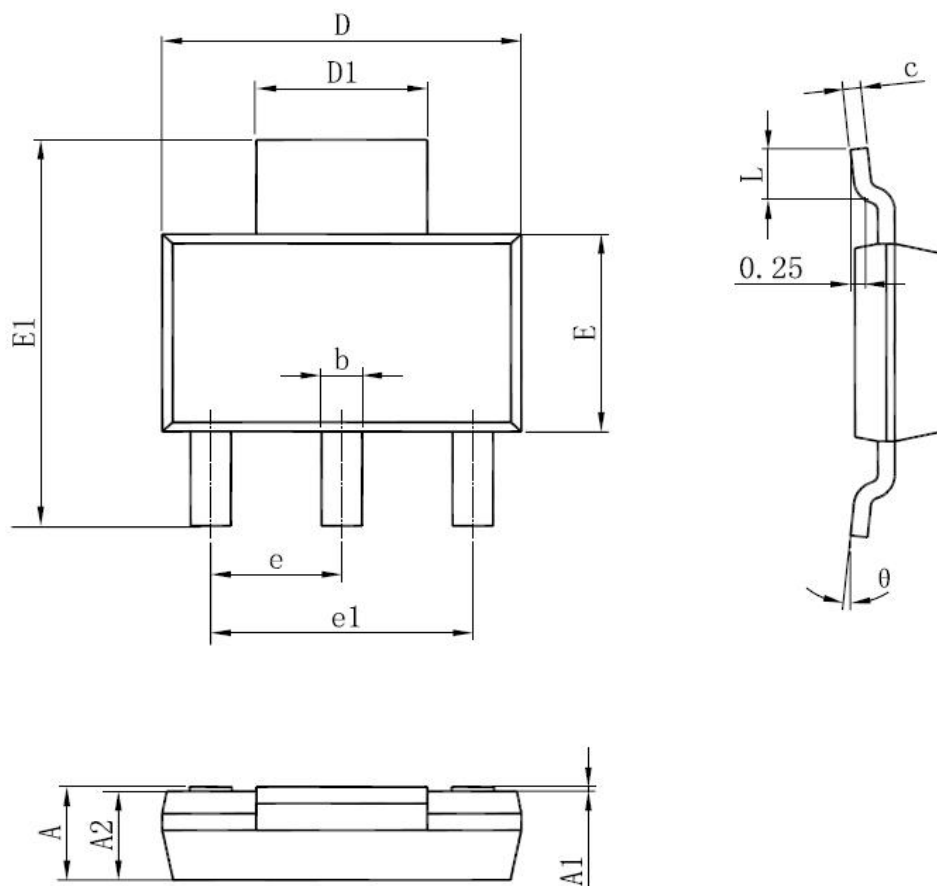

Symbol	Dimensions In Millimeters		Dimensions In Inches	
	Min	Max	Min	Max
A	1.520	1.800	0.060	0.071
A1	0.000	0.100	0.000	0.004
A2	1.500	1.700	0.059	0.067
b	0.660	0.820	0.026	0.032
c	0.250	0.350	0.010	0.014
D	6.200	6.400	0.244	0.252
D1	2.900	3.100	0.114	0.122
E	3.300	3.700	0.130	0.146
E1	6.830	7.070	0.269	0.278
e	2.300(BSC)		0.091(BSC)	
e1	4.500	4.700	0.177	0.185
L	0.900	1.150	0.035	0.045
θ	0°	10°	0°	10°

SOT-223 Package