

20V Full-Bridge of MOSFET

Description

Vj g"J O 6; 44" wugu'cf xcpegf "tgpej "vgej pqmqi { "vq" r tqxkf g"gzegngpv" T_{FUQP+} "cpf "mqy "i cvg"ej cti g"0Vj g" eqo r rgo gpvct { " O QUHGVi" o c { " dg" wugf " vq" hqto " c" J /Dtlf i g. "cpf "hqt "c" j quv'qh'qyj gt "cr r rdecvkpu0'

General Features

◆ N-channel:

$V_{DS} = 20V, I_D = 3A$

$R_{DS(ON)} = 32m\Omega$ (typical) @ $V_{GS} = 4.5V$

$R_{DS(ON)} = 42m\Omega$ (typical) @ $V_{GS} = 2.5V$

◆ P-Channel:

$V_{DS} = -20V, I_D = -3A$

$R_{DS(ON)} = 60m\Omega$ (typical) @ $V_{GS} = -4.5V$

$R_{DS(ON)} = 75m\Omega$ (typical) @ $V_{GS} = -2.5V$

- ◆ Excellent gate charge x $R_{DS(ON)}$ product(FOM)
- ◆ Very low on-resistance $R_{DS(ON)}$
- ◆ 150 °C operating temperature
- ◆ Pb-free lead plating
- ◆ 100% UIS tested

Application

- ◆ Complementary MOSFET for DC FAN, Motor
- ◆ Wireless Charging

Package

- ◆ SOP-8

Schematic diagram

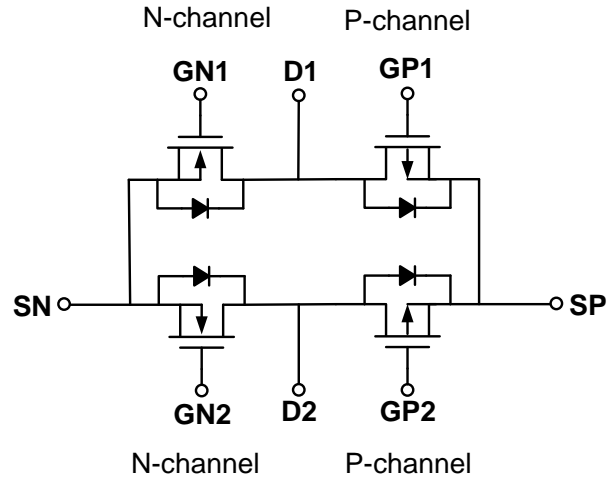

Marking and pin assignment

SOP-8 (TOP VIEW)

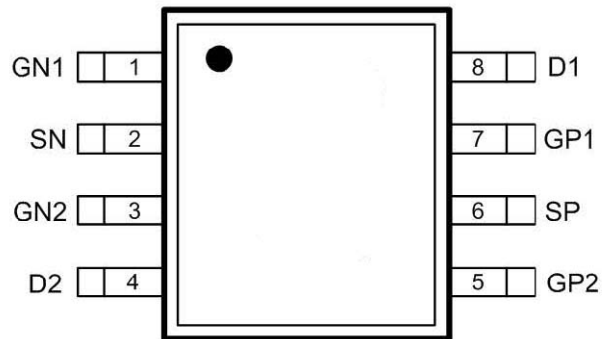

Ordering Information

Part Number	Storage Temperature	Package	Devices Per Reel
J O 6; 44UT	-55°C to +150°C	SOP-8	3000
J O 6; 44UH	-55°C to +150°C	SOP-8	4000

Absolute Maximum Ratings (TA=25°C unless otherwise noted)

Parameter	Symbol	Limit		Unit
		N	P	
Drain-source voltage	V_{DS}	20	-20	V

Gate-source voltage	V_{GS}	± 12	± 12	V
Maximum power dissipation	P_D	2.0	2.0	W
Operating junction Temperature range	T_j	-55—150	-55—150	°C
Drain Current-Continuous (Silicon Limited)	$T_A=25^\circ\text{C}$	I_D	3	A
	$T_A=75^\circ\text{C}$		2.5	
Pulsed Drain Current (Package Limited)	I_{DM}	12	-12	A
Power Dissipation ^B	$T_A=25^\circ\text{C}$	P_D	2	W
	$T_A=75^\circ\text{C}$		1.3	
Junction and Storage Temperature Range	T_j, T_{STG}	-55—150		°C

N-Channel Electrical Characteristics ($T_j=25^\circ\text{C}$ unless otherwise noted)

Parameter	Symbol	Condition	Min	Typ	Max	Unit
OFF Characteristics						
Drain-source breakdown voltage	BV_{DSS}	$V_{GS}=0V, I_D=250\mu A$	20	-	-	V
Zero gate voltage drain current	I_{DSS}	$V_{DS}=20V, V_{GS}=0V$	-	-	1	μA
Gate-body leakage	I_{GSS}	$V_{DS}=0V, V_{GS}=\pm 12V$	-	-	± 100	nA
ON Characteristics						
Gate threshold voltage	$V_{GS(th)}$	$V_{DS}=V_{GS}, I_D=250\mu A$	0.5	0.75	1.2	V
Drain-source on-state resistance	$R_{DS(on)}$	$V_{GS}=4.5V, I_D=3A$	-	31	50	m Ω
		$V_{GS}=2.5V, I_D=2.8A$	-	41	80	
Forward transconductance	gfs	$V_{GS}=5V, I_D=3A$	-	5	-	S
Dynamic Characteristics						
Input capacitance	C_{ISS}	$V_{DS}=10V, V_{GS}=0V$ $f=1.0\text{MHz}$	-	240	-	pF
Output capacitance	C_{OSS}		-	45	-	
Reverse transfer capacitance	C_{RSS}		-	23	-	
Gate resistance	R_g	$V_{GS}=0V, V_{DS}=0V,$ $f=1.0\text{MHz}$	-	3.3	4.9	Ω
Switching Characteristics						
Turn-on delay time	$t_{D(on)}$	$V_{DD}=10V$ $R_L=3.3\text{ohm}$ $V_{GEN}=4.5V$ $R_{GEN}=6\text{ohm}$	-	2.3	-	ns
Rise time	t_r		-	3.1	-	
Turn-off delay time	$t_{D(off)}$		-	21	-	
Fall time	t_f		-	2.6	-	
Total gate charge	Q_g	$V_{DS}=10V$ $I_D=3A$ $V_{GS}=4.5V$	-	2.7	-	nC
Gate-source charge	Q_{gs}		-	0.4	-	
Gate-drain charge	Q_{gd}		-	0.5	-	

Thermal Characteristics

Thermal Resistance junction-to ambient	$R_{th JA}$	100	°C/W
--	-------------	-----	------

N-Channel: Typical Electrical And Thermal Characteristics

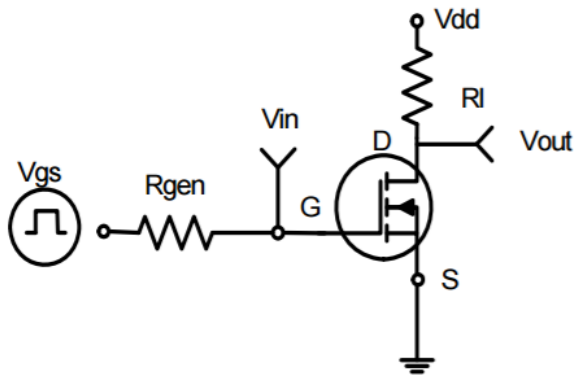

Figure 1: Switching Test Circuit

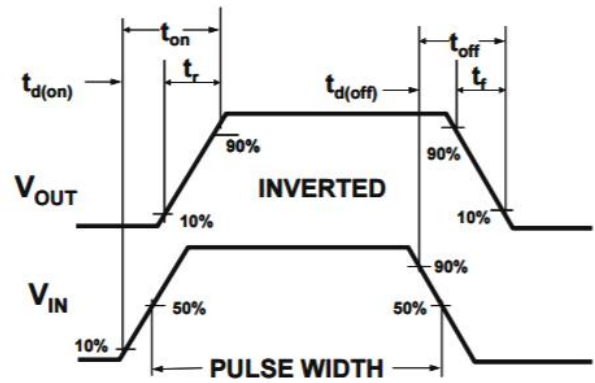

Figure 2: Switching Waveforms

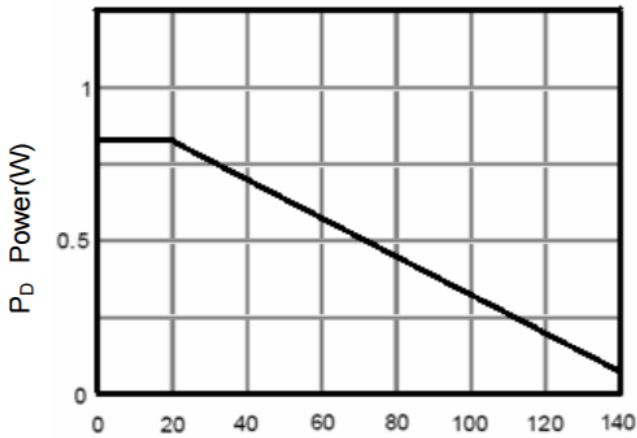

Figure 3 Power Dissipation

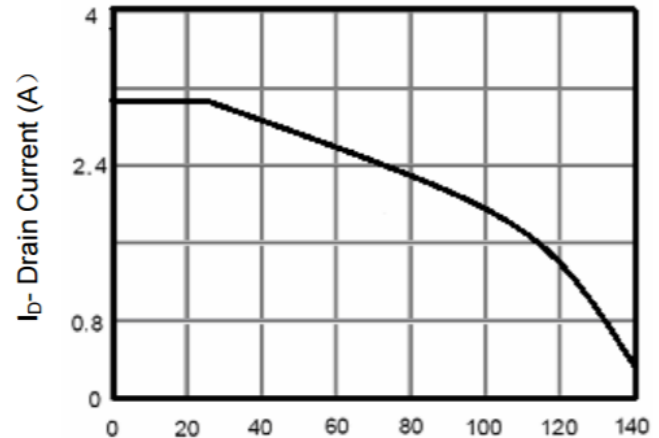

Figure 4 Drain Current

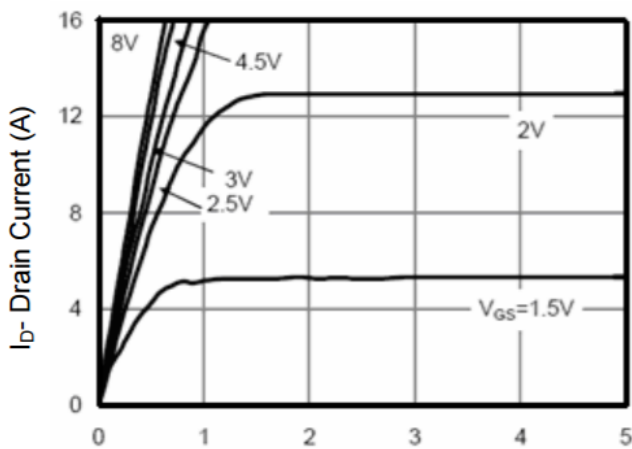

Figure 5 Output Characteristics

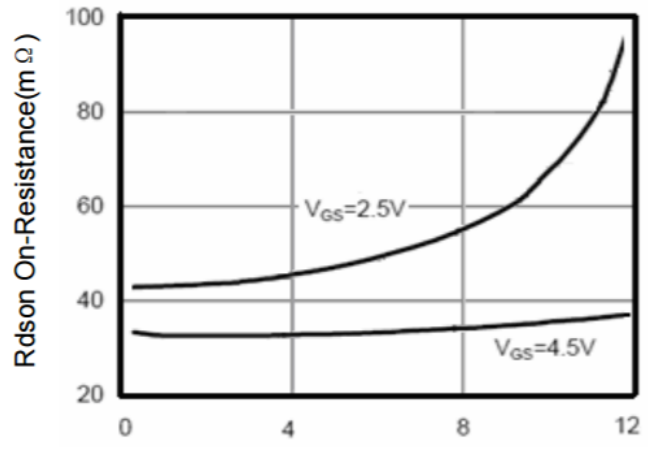

Figure 6 Drain-Source On-Resistance

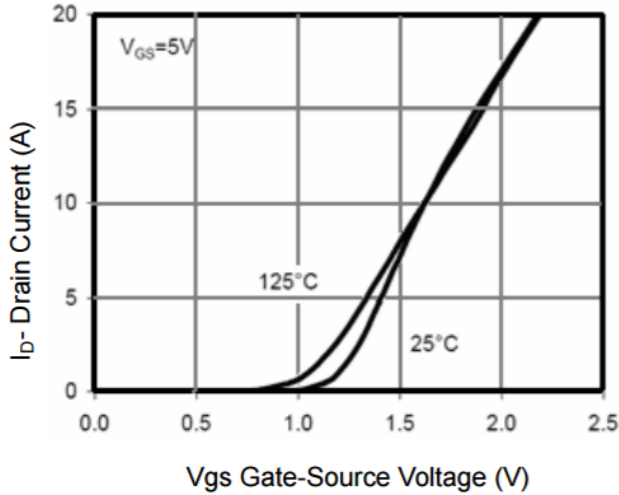

Figure 7 Transfer Characteristics

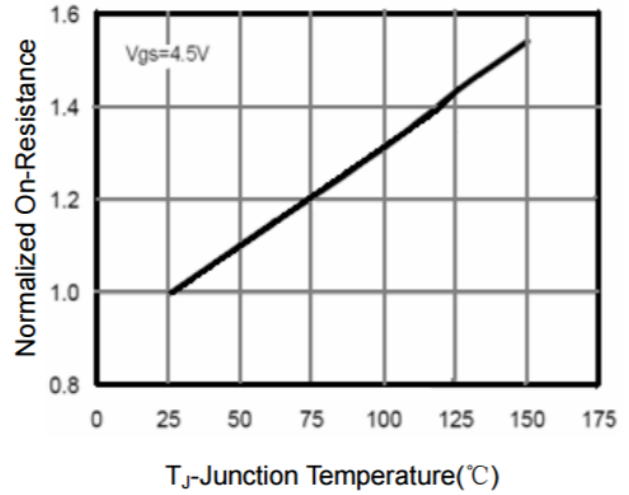

Figure 8 Drain-Source On-Resistance

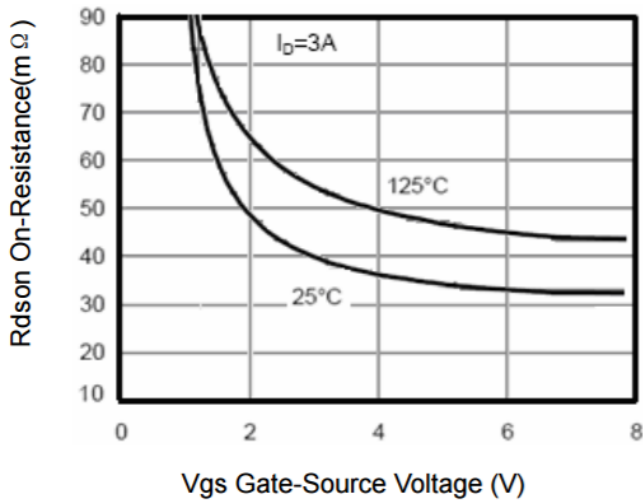

Figure 9 Rdson vs Vgs

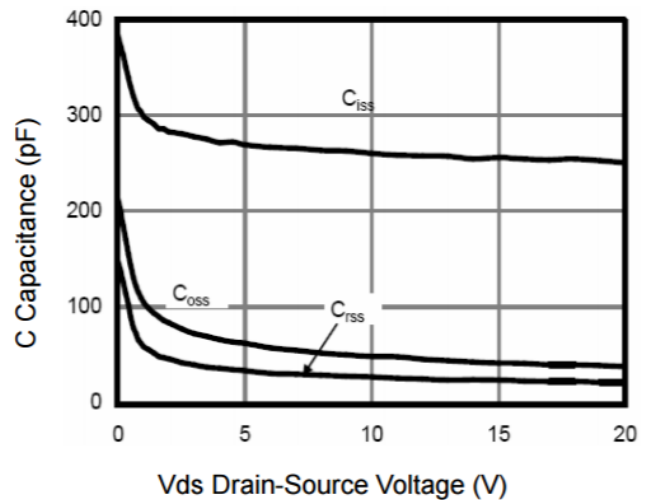

Figure 10 Capacitance vs Vds

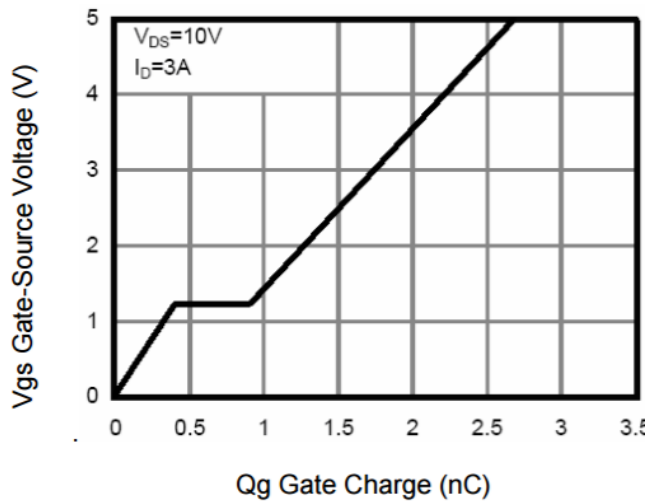

Figure 11 Gate Charge

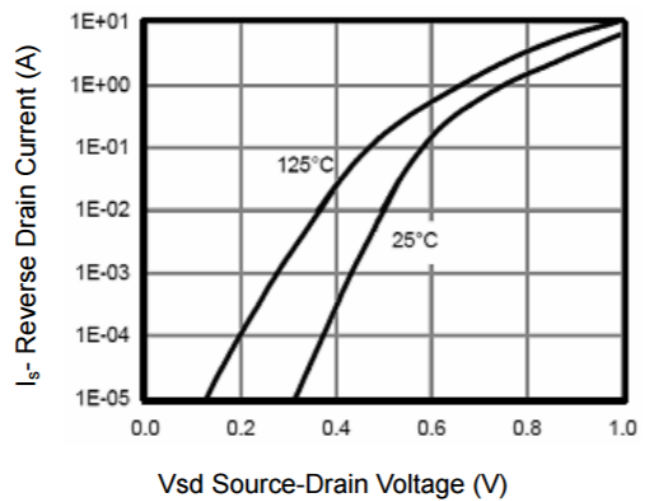

Figure 12 Source- Drain Diode Forward

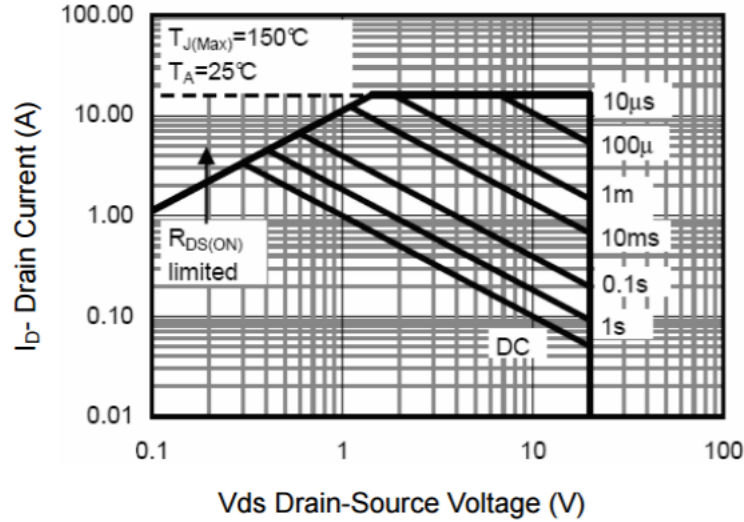

Figure 13 Safe Operation Area

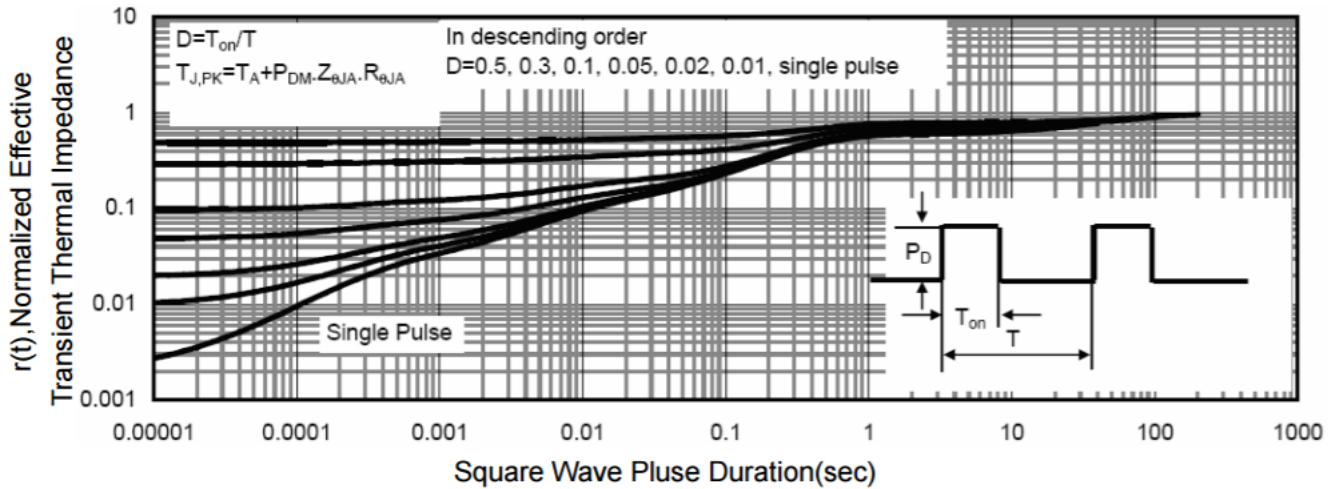
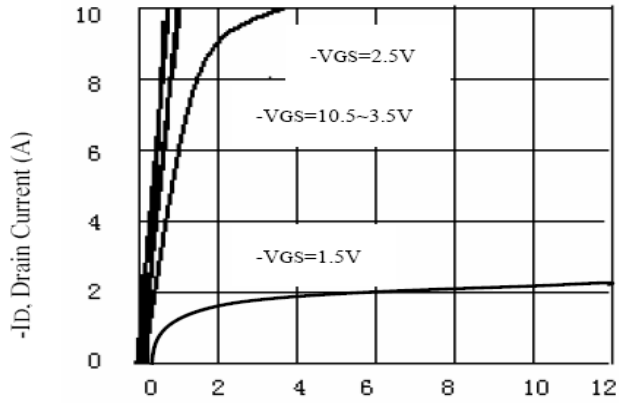

Figure 14 Normalized Maximum Transient Thermal Impedance

P-Channel Electrical Characteristics ($T_J=25^{\circ}\text{C}$ unless otherwise noted)

Parameter	Symbol	Condition	Min	Typ	Max	Unit
OFF Characteristics						
Drain-source breakdown voltage	BV_{DSS}	$V_{GS}=0V, I_D=-250\mu A$	-20	-	-	V
Zero gate voltage drain current	I_{DSS}	$V_{DS}=-20V, V_{GS}=0V$	-	-	-1	μA
Gate-body leakage	I_{GSS}	$V_{DS}=0V, V_{GS}=\pm 12V$	-	-	± 100	nA
ON Characteristics						
Gate threshold voltage	$V_{GS(th)}$	$V_{DS}=V_{GS}, I_D=-250\mu A$	-0.4	-0.65	-1.2	V
Drain-source on-state resistance	$R_{DS(ON)}$	$V_{GS}=-4.5V, I_D=-2.8A$	-	60	90	m Ω
		$V_{GS}=-2.5V, I_D=-2.8A$	-	75	120	
Forward transconductance	gfs	$V_{GS}=-5V, I_D=-5A$	-	5	-	S
Dynamic Characteristics						
Input capacitance	C_{ISS}	$V_{DS}=-10V, V_{GS}=0V$ $f=1.0\text{MHz}$	-	561	-	pF
Output capacitance	C_{OSS}		-	61	-	
Reverse transfer capacitance	C_{RSS}		-	52	-	
Switching Characteristics						
Turn-on delay time	$t_{D(ON)}$	$V_{DD}=-10V$ $I_D=-2.8A$ $V_{GEN}=-4.5V$ $R_L=10\text{ohm}$ $R_{GEN}=-60\text{ohm}$	-	12.5	-	ns
Rise time	t_r		-	6.6	-	
Turn-off delay time	$t_{D(OFF)}$		-	113	-	
Fall time	t_f		-	46.6	-	
Total gate charge	Qg	$V_{DS}=-10V, I_D=-3A$ $V_{GS}=-4.5V$	-	6.1	-	nC
Gate-source charge	Qgs		-	1.7	-	
Gate-drain charge	Qgd		-	1.2	-	

P-Channel: Typical Electrical And Thermal Characteristics



- Vds, Drain-to-Source Voltage (V)

Figure 1. Output Characteristics

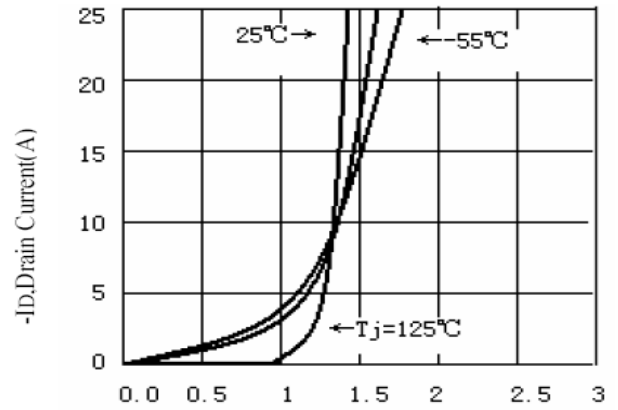

-Vgs, Gate-to-source Voltage (V)

Figure 2. Transfer Characteristics

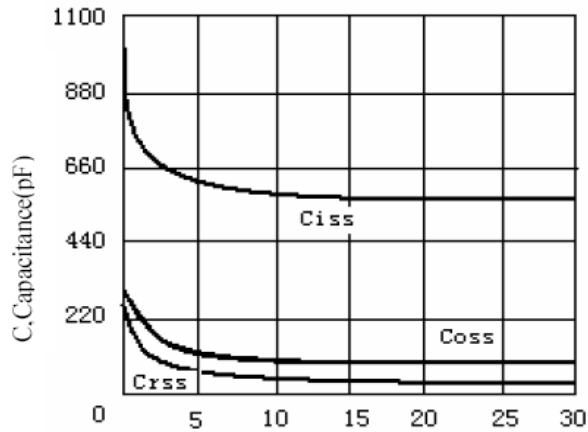

- VGS, Drain-to Source Voltage

Figure3. Capacitance

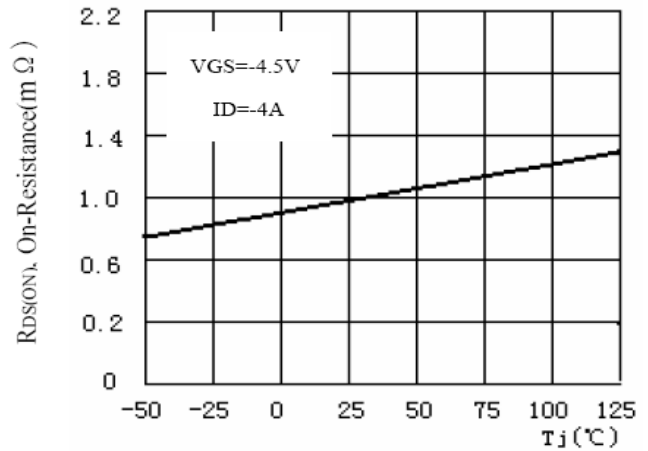
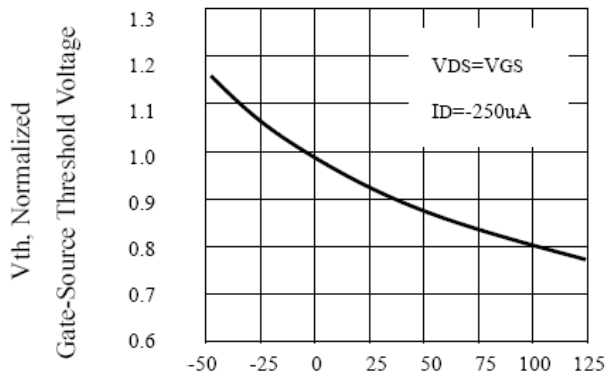
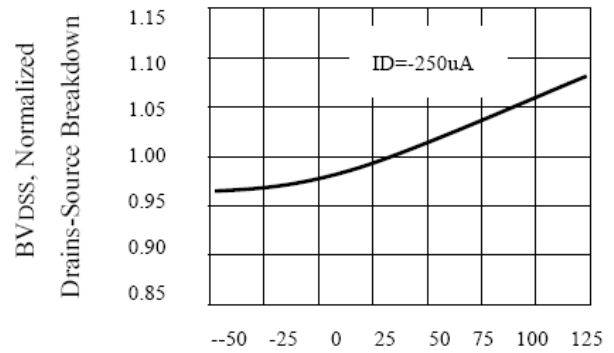

Figure4. On-Resistance Variation with Temperature



Tj, Junction Temperature(°C)

Figure5. Gate Threshold Variation With Temperature



Tj, Junction Temperature (°C)

Figure6. Breakdown Voltage Variation With Temperature

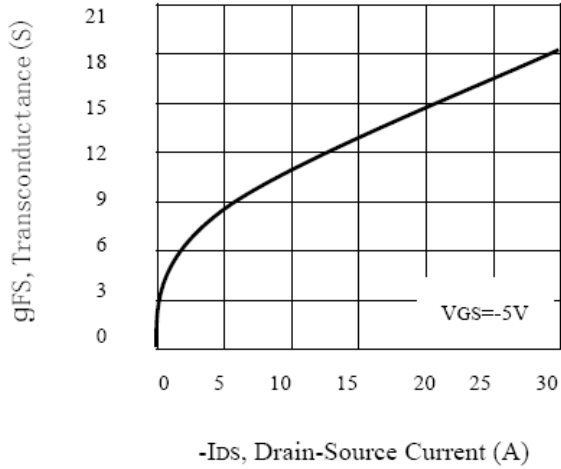

Figure7. Transconductance Variation With Drain Current

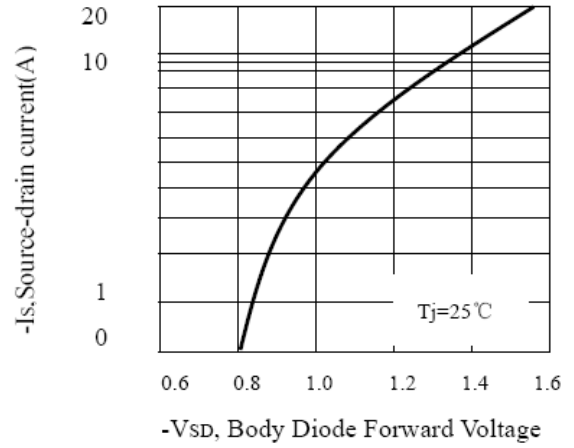

Figure8. Body Diode Forward Voltage Variation with Source Current

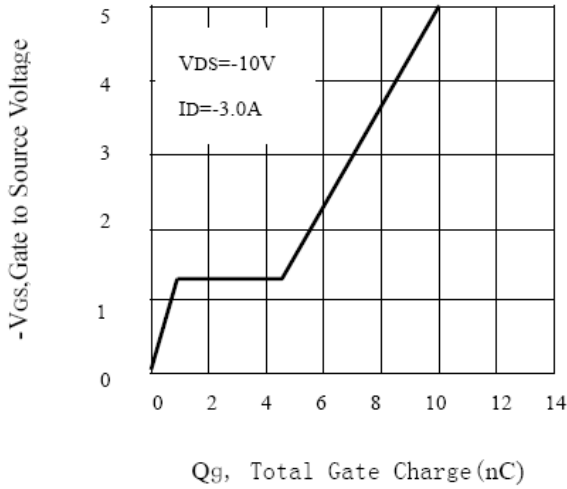

Figure9. Gate Charge

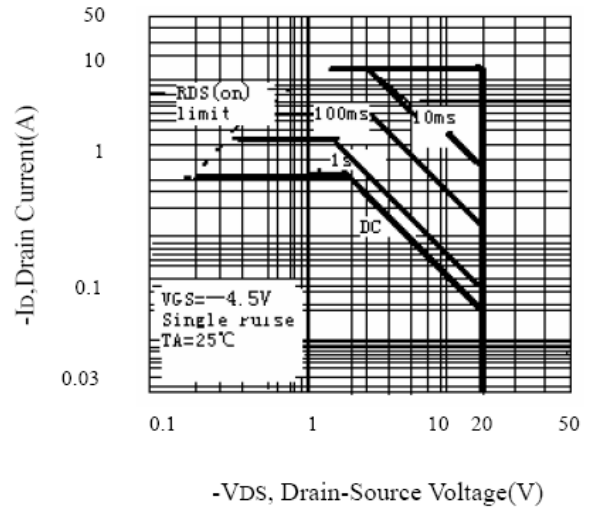
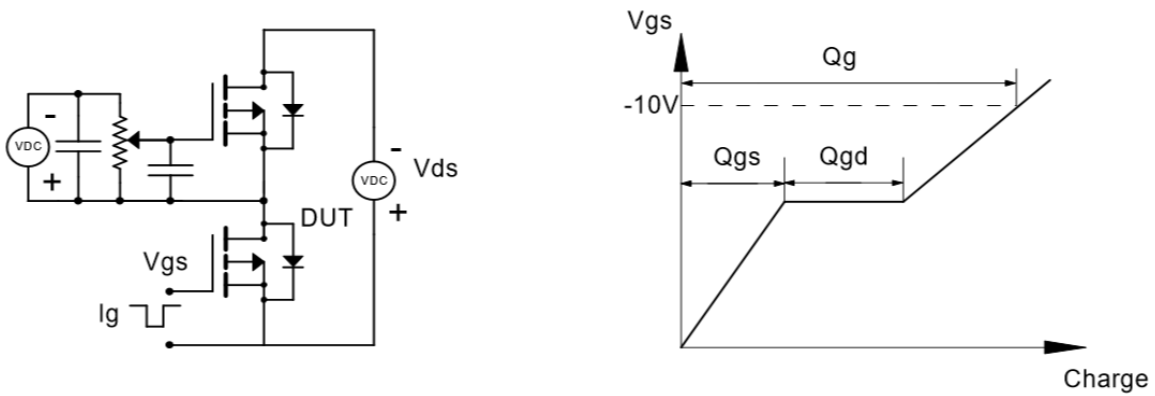
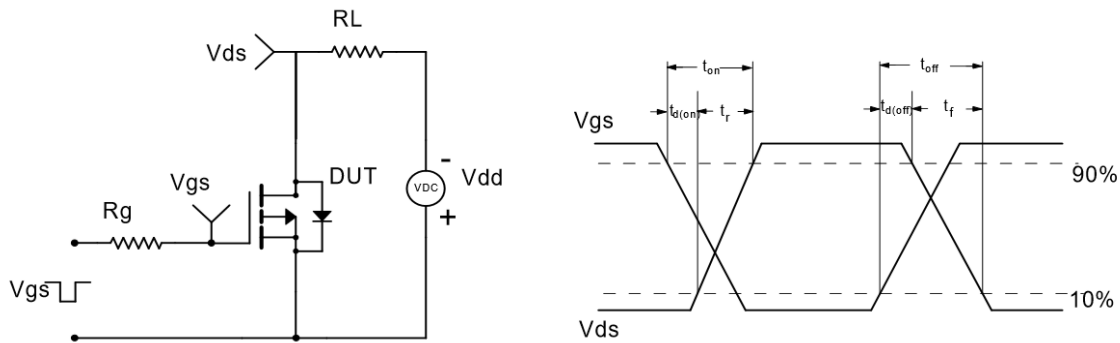

Figure10. Maximum Safe Operating Area

Gate Charge Test Circuit & Waveform



Resistive Switching Test Circuit & Waveforms



Unclamped Inductive Switching (UIS) Test Circuit & Waveforms

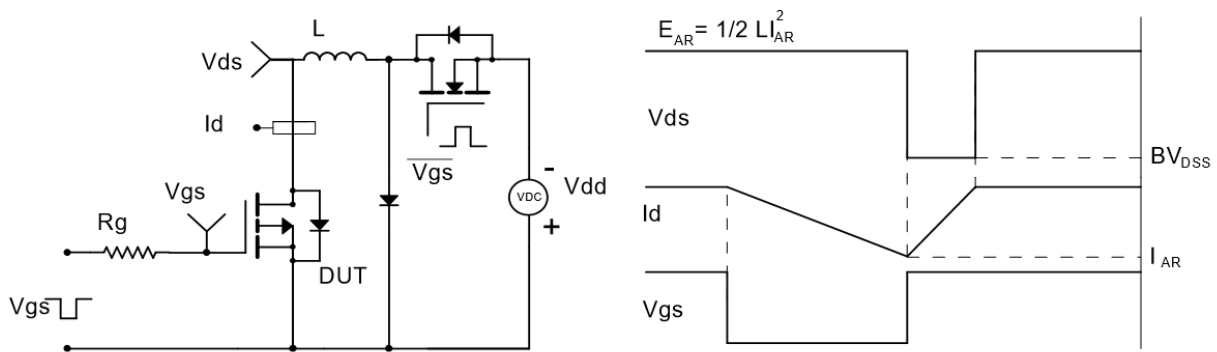

Diode Recovery Test Circuit & Waveforms

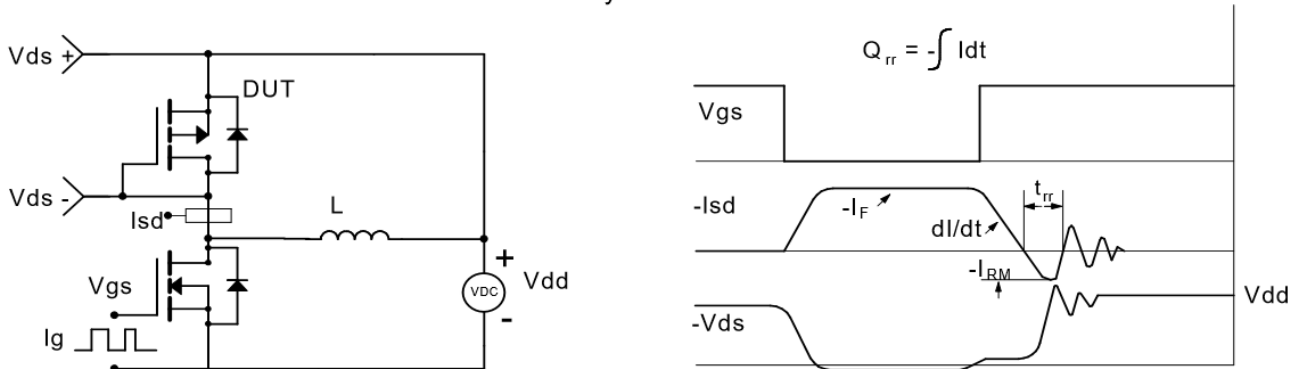

Package Information

- SOP-8

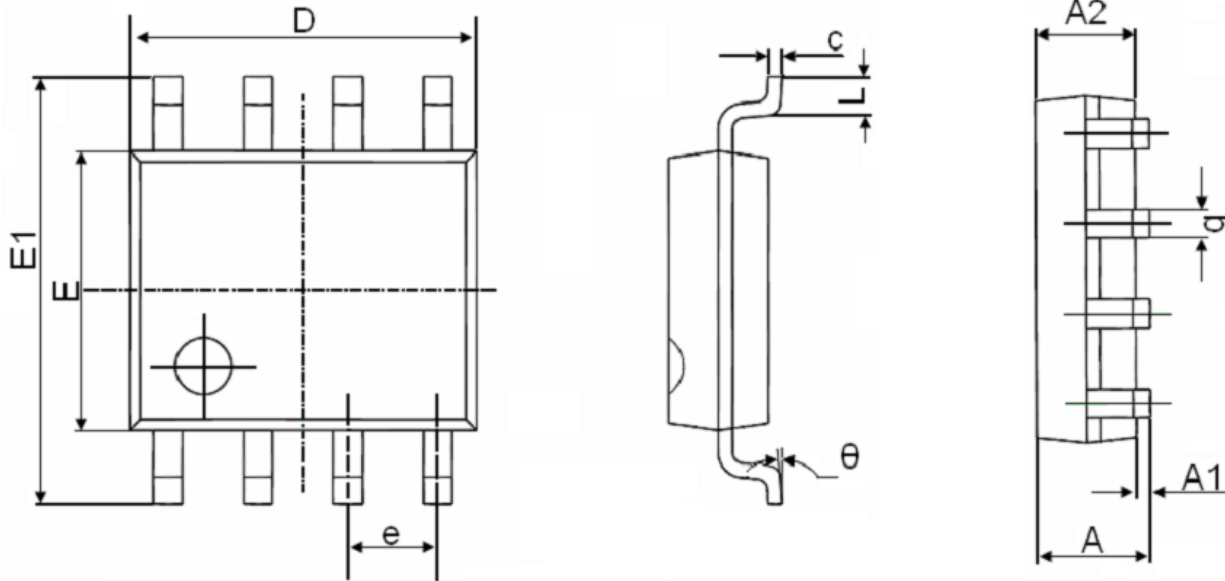

Symbol	Dimensions In Millimeters		Dimensions In Inches	
	Min.	Max.	Min.	Max.
A	1.350	1.750	0.053	0.069
A1	0.100	0.250	0.004	0.010
A2	1.350	1.550	0.053	0.061
b	0.330	0.510	0.013	0.020
c	0.170	0.250	0.006	0.010
D	4.700	5.100	0.185	0.200
E	3.800	4.000	0.150	0.157
E1	5.800	6.200	0.228	0.244
e	1.270(BSC)		0.050(BSC)	
L	0.400	1.270	0.016	0.050
theta	0°	8°	0°	8°