

---

# HM514170C Series HM51S4170C Series

262,144-word × 16-bit Dynamic Random Access Memory

# HITACHI

Rev. 1.0  
Jul. 21, 1995

---

## Description

The Hitachi HM51(S)4170C are CMOS dynamic RAM organized as 262,144-word × 16-bit. HM51(S)4170C have realized higher density, higher performance and various functions by employing 0.8 μm CMOS process technology and some new CMOS circuit design technologies. The HM51(S)4170C offer fast page mode as a high speed access mode. Multiplexed address input permits the HM51(S)4170C to be packaged in standard 400-mil 40-pin plastic SOJ and standard 400-mil 44-pin plastic TSOPII. Internal refresh timer enables HM51S4170C self refresh operation.

## Features

- Single 5 V (±10%)
- High speed
  - Access time: 70 ns/80 ns (max)
- Low power dissipation
  - Active mode: 660 mW/578 mW (max)
  - Standby mode: 11 mW (max)  
1.1 mW (max) (L-version)
- Fast page mode capability
- 1024 refresh cycles: 16 ms  
128 ms (L-version)
- 2  $\overline{WE}$  -byte control
- 2 variations of refresh
  - $\overline{RAS}$  -only refresh
  - $\overline{CAS}$  -before- $\overline{RAS}$  refresh
- Battery backup operation (L-version)
- Self refresh operation (HM51S4170C)

**HM514170C, HM51S4170C Series****Ordering Information**

<b>Type No.</b>	<b>Access Time</b>	<b>Package</b>
HM514170CJ-7 HM514170CJ-8	70 ns 80 ns	400-mil 40-pin plastic SOJ (CP-40DA)
HM514170CLJ-7 HM514170CLJ-8	70 ns 80 ns	
HM51S4170CJ-7 HM51S4170CJ-8	70 ns 80 ns	
HM51S4170CLJ-7 HM51S4170CLJ-8	70 ns 80 ns	
HM514170CTT-7 HM514170CTT-8	70 ns 80 ns	400-mil 44-pin plastic TSOPII (TTP-44/40DB)
HM514170CLTT-7 HM514170CLTT-8	70 ns 80 ns	
HM51S4170CTT-7 HM51S4170CTT-8	70 ns 80 ns	
HM51S4170CLTT-7 HM51S4170CLTT-8	70 ns 80 ns	

## Pin Arrangement

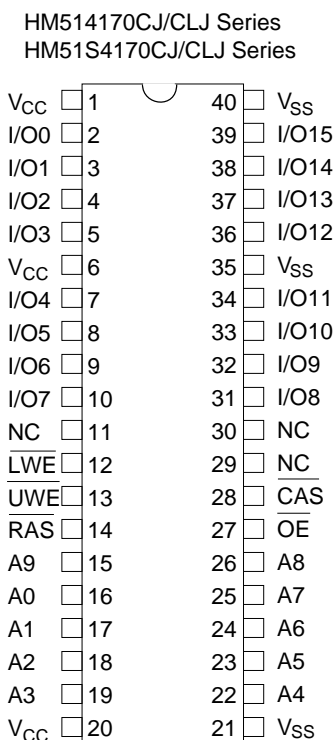

(Top view)

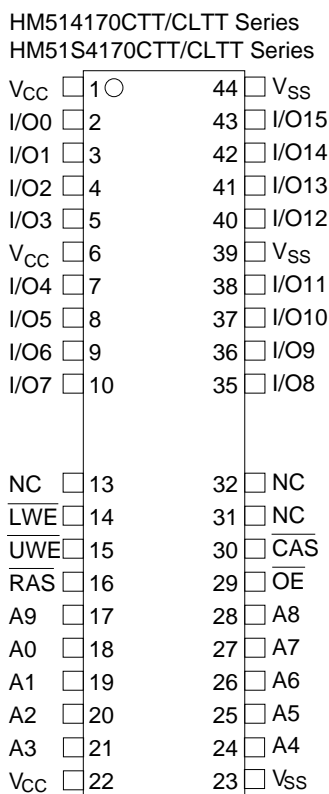

(Top view)

## Pin Description

Pin Name	Function
A0 – A9	Address input – Row address A0 – A9 – Column address A0 – A7 – Refresh address A0 – A9
I/O0 – I/O15	Data-in/data-out
$\overline{\text{RAS}}$	Row address strobe
$\overline{\text{CAS}}$	Column address strobe
$\overline{\text{UWE}} / \overline{\text{LWE}}$	Read/write enable
$\overline{\text{OE}}$	Output enable
V <sub>CC</sub>	Power (+5 V)
V <sub>SS</sub>	Ground
NC	No connection

# HM514170C, HM51S4170C Series

## Block Diagram

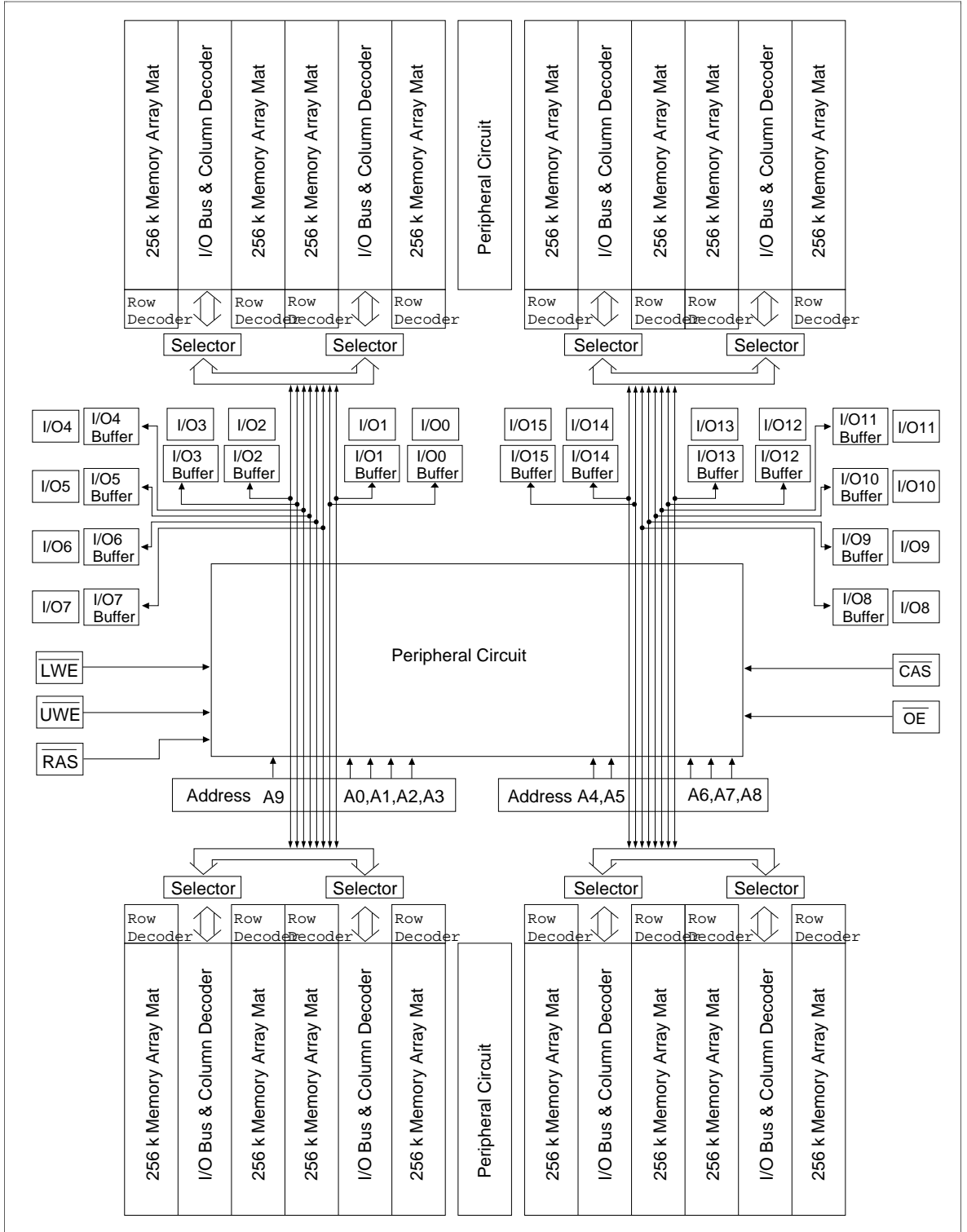

## Operation Mode

The HM51(S)4170C series has the following 11 operation modes.

1. Read cycle
2. Early write cycle
3. Delayed write cycle
4. Read-modify-write cycle
5.  $\overline{\text{RAS}}$  -only refresh cycle
6.  $\overline{\text{CAS}}$  -before- $\overline{\text{RAS}}$  refresh cycle
7. Self refresh cycle (HM51S4170C)
8. Fast page mode read cycle
9. Fast page mode early write cycle
10. Fast page mode delayed write cycle
11. Fast page mode read-modify-write cycle

Inputs					
$\overline{\text{RAS}}$	$\overline{\text{CAS}}$	$\overline{\text{UWE}}$	$\overline{\text{LWE}}$	Output	Operation
H	H	D	D	Open	Standby
H	L	H	H	Valid	Standby
L	L	H	H	Valid	Read cycle
L	L	L <sup>2</sup>	L <sup>2</sup>	Open	Early write cycle
L	L	L <sup>2</sup>	L <sup>2</sup>	Undefined	Delayed write cycle
L	L	H to L	H to L	Valid	Read-modify-write cycle
L	H	D	D	Open	$\overline{\text{RAS}}$ -only refresh cycle
H to L	L	D	D	Open	$\overline{\text{CAS}}$ -before- $\overline{\text{RAS}}$ refresh cycle Self refresh cycle (HM51S4170C)
L	H to L	H	H	Valid	Fast page mode read cycle
L	H to L	L <sup>2</sup>	L <sup>2</sup>	Open	Fast page mode early write cycle
L	H to L	L <sup>2</sup>	L <sup>2</sup>	Undefined	Fast page mode delayed write cycle
L	H to L	H to L	H to L	Valid	Fast page mode read modify-write cycle

Notes: 1. H: High (inactive) L: Low (active) D: H or L

2.  $t_{\text{wCS}} \geq 0$  ns Early write cycle

$t_{\text{wCS}} < 0$  ns Delay write cycle

3. Mode is determined by the OR function of the  $\overline{\text{UWE}}$  and  $\overline{\text{LWE}}$ . (Mode is set by the earliest of  $\overline{\text{UWE}}$  and  $\overline{\text{LWE}}$  active edge and reset by the latest of  $\overline{\text{UWE}}$  and  $\overline{\text{LWE}}$  inactive edge.) However write OPERATION and output HIZ control are done independently by each  $\overline{\text{UWE}}$ ,  $\overline{\text{LWE}}$ .

**HM514170C, HM51S4170C Series****Absolute Maximum Ratings**

Parameter	Symbol	Value	Unit
Voltage on any pin relative to $V_{SS}$	$V_T$	-1.0 to +7.0	V
Supply voltage relative to $V_{SS}$	$V_{CC}$	-1.0 to +7.0	V
Short circuit output current	$I_{out}$	50	mA
Power dissipation	$P_T$	1.0	W
Operating temperature	$T_{opr}$	0 to +70	°C
Storage temperature	$T_{stg}$	-55 to +125	°C

**Recommended DC Operating Conditions ( $T_a = 0$  to +70°C)**

Parameter	Symbol	Min	Typ	Max	Unit	Note
Supply voltage	$V_{SS}$	0	0	0	V	2
	$V_{CC}$	4.5	5.0	5.5	V	1, 2
Input high voltage	$V_{IH}$	2.4	—	6.5	V	1
Input low voltage	$V_{IL}$	-1.0	—	0.8	V	1

Notes: 1. All voltage referred to  $V_{SS}$

2. The supply voltage with all  $V_{CC}$  pins must be on the same level.

The supply voltage with all  $V_{SS}$  pins must be on the same level.

**DC Characteristics ( $T_a = 0$  to +70°C,  $V_{CC} = 5\text{ V} \pm 10\%$ ,  $V_{SS} = 0\text{ V}$ )**

		HM514170C, HM51S4170C					
		-7		-8			
Parameter	Symbol	Min	Max	Min	Max	Unit	Test Conditions
Operating current <sup>*1, *2</sup>	$I_{CC1}$	—	120	—	105	mA	$\overline{RAS}$ , $\overline{CAS}$ cycling $t_{RC} = \text{min}$
Standby current	$I_{CC2}$	—	2	—	2	mA	TTL interface $\overline{RAS}$ , $\overline{CAS} = V_{IH}$ Dout = High-Z
		—	1	—	1	mA	CMOS interface $\overline{RAS}$ , $\overline{CAS}$ , $\overline{UWE}$ , $\overline{LWE}$ , $\overline{OE} \geq V_{CC} - 0.2\text{ V}$ Dout = High-Z
Standby current (L-version)	$I_{CC2}$	—	200	—	200	$\mu\text{A}$	CMOS interface $\overline{RAS}$ , $\overline{CAS}$ , $\overline{OE}$ , $\overline{UWE}$ , $\overline{LWE} \geq V_{CC} - 0.2\text{ V}$ Dout = High
$\overline{RAS}$ -only refresh current <sup>*2</sup>	$I_{CC3}$	—	120	—	100	mA	$t_{RC} = \text{min}$

DC Characteristics (Ta = 0 to +70°C, V<sub>CC</sub> = 5 V ± 10%, V<sub>SS</sub> = 0 V) (cont)

Parameter	Symbol	HM514170C, HM51S4170C				Unit	Test Conditions
		-7		-8			
		Min	Max	Min	Max		
Standby current <sup>1</sup>	I <sub>CC5</sub>	—	5	—	5	mA	$\overline{\text{RAS}} = V_{\text{IH}}, \overline{\text{CAS}} = V_{\text{IL}}$ Dout = enable
$\overline{\text{CAS}}$ -before- $\overline{\text{RAS}}$ refresh current <sup>2</sup>	I <sub>CC6</sub>	—	120	—	100	mA	t <sub>RC</sub> = min
Fast page mode current <sup>1, 3</sup>	I <sub>CC7</sub>	—	130	—	120	mA	t <sub>PC</sub> = min
Battery backup current <sup>4</sup> (Standby with CBR refresh) (L-version)	I <sub>CC10</sub>	—	300	—	300	μA	Standby: CMOS interface Dout = High-Z CBR refresh: t <sub>RC</sub> = 125 μs t <sub>RAS</sub> ≤ 1 μs, $\overline{\text{CAS}} = V_{\text{IL}}$ $\overline{\text{UWE}}, \overline{\text{LWE}}, \overline{\text{OE}} = V_{\text{IH}}$
Self-refresh mode current (HM51S4170C)	I <sub>CC11</sub>	—	1	—	1	mA	CMOS interface $\overline{\text{RAS}}, \overline{\text{CAS}} \leq 0.2 \text{ V}$ , Dout = High-Z
Self-refresh mode current (HM51S4170CL)	I <sub>CC11</sub>	—	200	—	200	μA	CMOS interface $\overline{\text{RAS}}, \overline{\text{CAS}} \leq 0.2 \text{ V}$ , Dout = High-Z
Input leakage current	I <sub>LI</sub>	-10	10	-10	10	μA	0 V ≤ Vin ≤ 6.5 V
Output leakage current	I <sub>LO</sub>	-10	10	-10	10	μA	0 V ≤ Vout ≤ 6.5 V Dout = disable
Output high voltage	V <sub>OH</sub>	2.4	V <sub>CC</sub>	2.4	V <sub>CC</sub>	V	High Iout = -5.0 mA
Output low voltage	V <sub>OL</sub>	0	0.4	0	0.4	V	Low Iout = 4.2 mA

- Notes: 1. I<sub>CC</sub> depends on output load condition when the device is selected. I<sub>CC</sub> max is specified at the output open condition.  
 2. Address can be changed once or less while  $\overline{\text{RAS}} = V_{\text{IL}}$ .  
 3. Address can be changed once or less while  $\overline{\text{CAS}} = V_{\text{IH}}$ .  
 4.  $V_{\text{IH}} \geq V_{\text{CC}} - 0.2 \text{ V}$ ,  $0 \leq V_{\text{IL}} \leq 0.2 \text{ V}$ , Address can be changed once or less while  $\overline{\text{RAS}} = V_{\text{IL}}$ .  
 5. All the V<sub>CC</sub> pins shall be supplied with the same voltage. And all the V<sub>SS</sub> pins shall be supplied with the same voltage.

Capacitance (Ta = 25°C, V<sub>CC</sub> = 5 V ± 10%)

Parameter	Symbol	Typ	Max	Unit	Notes
Input capacitance (Address)	C <sub>I1</sub>	—	5	pF	1
Input capacitance (Clocks)	C <sub>I2</sub>	—	7	pF	1
Output capacitance (Data-in, Data-out)	C <sub>I/O</sub>	—	10	pF	1, 2

- Notes: 1. Capacitance measured with Boonton Meter or effective capacitance measuring method.  
 2.  $\overline{\text{CAS}} = V_{\text{IH}}$  to disable Dout.

**HM514170C, HM51S4170C Series****AC Characteristics** ( $T_a = 0$  to  $+70^\circ\text{C}$ ,  $V_{CC} = 5\text{ V} \pm 10\%$ ,  $V_{SS} = 0\text{ V}$ )<sup>\*1, \*14, \*15, \*17, \*18</sup>**Test Conditions****Read, Write, Read-Modify-Write and Refresh Cycles** (Common Parameters)

- Input rise and fall time: 5 ns
- Input timing reference levels: 0.8 V, 2.4 V
- Input levels: 0 V, 3 V
- Output load: 2 TTL gate +  $C_L$  (100 pF) (Including scope and jig)

Parameter	Symbol	HM514170C, HM51S4170C				Unit	Notes
		-7		-8			
		Min	Max	Min	Max		
Random read or write cycle time	$t_{RC}$	130	—	150	—	ns	
$\overline{\text{RAS}}$ precharge time	$t_{RP}$	50	—	60	—	ns	
$\overline{\text{RAS}}$ pulse width	$t_{RAS}$	70	10000	80	10000	ns	
$\overline{\text{CAS}}$ pulse width	$t_{CAS}$	20	10000	20	10000	ns	22
Row address setup time	$t_{ASR}$	0	—	0	—	ns	
Row address hold time	$t_{RAH}$	10	—	10	—	ns	
Column address setup time	$t_{ASC}$	0	—	0	—	ns	
Column address hold time	$t_{CAH}$	15	—	15	—	ns	
$\overline{\text{RAS}}$ to $\overline{\text{CAS}}$ delay time	$t_{RCD}$	20	50	20	60	ns	8
$\overline{\text{RAS}}$ to column address delay time	$t_{RAD}$	15	35	15	40	ns	9
$\overline{\text{RAS}}$ hold time	$t_{RSH}$	20	—	20	—	ns	
$\overline{\text{CAS}}$ hold time	$t_{CSH}$	70	—	80	—	ns	
$\overline{\text{CAS}}$ to $\overline{\text{RAS}}$ precharge time	$t_{CRP}$	15	—	15	—	ns	23
$\overline{\text{OE}}$ to Din delay time	$t_{ODD}$	20	—	20	—	ns	
$\overline{\text{OE}}$ delay time from Din	$t_{DZO}$	0	—	0	—	ns	
$\overline{\text{CAS}}$ setup time from Din	$t_{DZC}$	0	—	0	—	ns	
Transition time (rise and fall)	$t_T$	3	50	3	50	ns	7
Refresh period	$t_{REF}$	—	16	—	16	ms	
Refresh period (L-version)	$t_{REF}$	—	128	—	128	ms	



## Read Cycle

Parameter	Symbol	HM514170C, HM51S4170C				Unit	Notes
		-7		-8			
		Min	Max	Min	Max		
Access time from $\overline{\text{RAS}}$	$t_{\text{RAC}}$	—	70	—	80	ns	2, 3
Access time from $\overline{\text{CAS}}$	$t_{\text{CAC}}$	—	20	—	20	ns	3, 4, 13
Access time from address	$t_{\text{AA}}$	—	35	—	40	ns	3, 5, 13
Access time from $\overline{\text{OE}}$	$t_{\text{OAC}}$	—	20	—	20	ns	22
Read command setup time	$t_{\text{RCS}}$	0	—	0	—	ns	20
Read command hold time to $\overline{\text{CAS}}$	$t_{\text{RCH}}$	0	—	0	—	ns	16, 19
Read command hold time to $\overline{\text{RAS}}$	$t_{\text{RRH}}$	0	—	0	—	ns	16
Column address to $\overline{\text{RAS}}$ lead time	$t_{\text{RAL}}$	35	—	40	—	ns	
Output buffer turn-off time	$t_{\text{OFF1}}$	0	15	0	15	ns	6
Output buffer turn-off to $\overline{\text{OE}}$	$t_{\text{OFF2}}$	0	15	0	15	ns	6
$\overline{\text{CAS}}$ to $\text{Din}$ delay time	$t_{\text{CDD}}$	15	—	15	—	ns	

## Write Cycle

Parameter	Symbol	HM514170C, HM51S4170C				Unit	Notes
		-7		-8			
		Min	Max	Min	Max		
Write command setup time	$t_{\text{WCS}}$	0	—	0	—	ns	10, 19
Write command hold time	$t_{\text{WCH}}$	15	—	15	—	ns	20
Write command pulse width	$t_{\text{WP}}$	10	—	10	—	ns	21
Write command to $\overline{\text{RAS}}$ lead time	$t_{\text{RWL}}$	20	—	20	—	ns	21
Write command to $\overline{\text{CAS}}$ lead time	$t_{\text{CWL}}$	20	—	20	—	ns	21
Data-in setup time	$t_{\text{DS}}$	0	—	0	—	ns	11, 21
Data-in hold time	$t_{\text{DH}}$	15	—	15	—	ns	11, 21
$\overline{\text{CAS}}$ to $\overline{\text{OE}}$ delay time	$t_{\text{COD}}$	—	0	—	0	ns	22

**HM514170C, HM51S4170C Series****Read-Modify-Write Cycle**

Parameter	Symbol	HM514170C, HM51S4170C				Unit	Notes
		-7		-8			
		Min	Max	Min	Max		
Read-modify-write cycle time	$t_{RWC}$	180	—	200	—	ns	
$\overline{RAS}$ to $\overline{WE}$ delay time	$t_{RWD}$	95	—	105	—	ns	10, 19
$\overline{CAS}$ to $\overline{WE}$ delay time	$t_{CWD}$	45	—	45	—	ns	10, 19
Column address to $\overline{WE}$ delay time	$t_{AWD}$	60	—	65	—	ns	10, 19
$\overline{OE}$ hold time from $\overline{WE}$	$t_{OEH}$	20	—	20	—	ns	21

**Refresh Cycle**

Parameter	Symbol	HM514170C, HM51S4170C				Unit	Notes
		-7		-8			
		Min	Max	Min	Max		
$\overline{CAS}$ setup time (CBR refresh cycle)	$t_{CSR}$	10	—	10	—	ns	19
$\overline{CAS}$ hold time (CBR refresh cycle)	$t_{CHR}$	10	—	10	—	ns	20
$\overline{RAS}$ precharge to $\overline{CAS}$ hold time	$t_{RPC}$	10	—	10	—	ns	19
$\overline{CAS}$ precharge time in normal mode	$t_{CPN}$	10	—	10	—	ns	

**Fast Page Mode Cycle**

Parameter	Symbol	HM514170C, HM51S4170C				Unit	Notes
		-7		-8			
		Min	Max	Min	Max		
Fast page mode cycle time	$t_{PC}$	45	—	50	—	ns	
Fast page mode $\overline{CAS}$ precharge time	$t_{CP}$	10	—	10	—	ns	
Fast page mode $\overline{RAS}$ pulse width	$t_{RASC}$	—	100000	—	100000	ns	12
Access time from $\overline{CAS}$ precharge	$t_{ACP}$	—	40	—	45	ns	3, 13
RAS hold time from $\overline{CAS}$ precharge	$t_{RHCP}$	40	—	45	—	ns	
Fast page mode read-modify-write cycle $\overline{CAS}$ precharge to $\overline{UWE}$ , $\overline{LWE}$ delay time	$t_{CPW}$	65	—	70	—	ns	21
Fast page mode read-modify-write cycle time	$t_{PCM}$	95	—	100	—	ns	



## Self refresh Mode

Parameter	Symbol	HM51S4170C				Unit	Notes
		-7		-8			
		Min	Max	Min	Max		
$\overline{\text{RAS}}$ pulse width (self refresh)	$t_{\text{RASS}}$	100	—	100	—	$\mu\text{s}$	23, 24, 25
$\overline{\text{RAS}}$ precharge time (self refresh)	$t_{\text{RPS}}$	130	—	150	—	ns	
$\overline{\text{CAS}}$ hold time (self refresh)	$t_{\text{CHS}}$	-50	—	-50	—	ns	

Notes: 1. AC measurements assume  $t_{\tau} = 5 \text{ ns}$ .

- Assumes that  $t_{\text{RCD}} \leq t_{\text{RCD}} (\text{max})$  and  $t_{\text{RAD}} \leq t_{\text{RAD}} (\text{max})$ . If  $t_{\text{RCD}}$  or  $t_{\text{RAD}}$  is greater than the maximum recommended value shown in this table,  $t_{\text{RAC}}$  exceeds the value shown.
- Measured with a load circuit equivalent to 2 TTL loads and 100 pF.
- Assumes that  $t_{\text{RCD}} \geq t_{\text{RCD}} (\text{max})$  and  $t_{\text{RAD}} \leq t_{\text{RAD}} (\text{max})$ .
- Assumes that  $t_{\text{RCD}} \leq t_{\text{RCD}} (\text{max})$  and  $t_{\text{RAD}} \geq t_{\text{RAD}} (\text{max})$ .
- $t_{\text{OFF}} (\text{max})$  defines the time at which the output achieves the open circuit condition and is not referred to output voltage levels.
- $V_{\text{IH}} (\text{min})$  and  $V_{\text{IL}} (\text{max})$  are reference levels for measuring timing of input signals. Also, transition times are measured between  $V_{\text{IH}}$  and  $V_{\text{IL}}$ .
- Operation with the  $t_{\text{RCD}} (\text{max})$  limit insures that  $t_{\text{RAC}} (\text{max})$  can be met,  $t_{\text{RCD}} (\text{max})$  is specified as a reference point only, if  $t_{\text{RCD}}$  is greater than the specified  $t_{\text{RCD}} (\text{max})$  limit, then access time is controlled exclusively by  $t_{\text{CAC}}$ .
- Operation with the  $t_{\text{RAD}} (\text{max})$  limit insures that  $t_{\text{RAC}} (\text{max})$  can be met,  $t_{\text{RAD}} (\text{max})$  is specified as a reference point only, if  $t_{\text{RAD}}$  is greater than the specified  $t_{\text{RAD}} (\text{max})$  limit, then access time is controlled exclusively by  $t_{\text{AA}}$ .
- $t_{\text{WCS}}$ ,  $t_{\text{RWD}}$ ,  $t_{\text{CWD}}$  and  $t_{\text{AWD}}$  are not restrictive operating parameters. They are included in the data sheet as electrical characteristics only: if  $t_{\text{WCS}} \geq t_{\text{WCS}} (\text{min})$ , the cycle is an early write cycle and the data out pin will remain open circuit (high impedance) throughout the entire cycle; if  $t_{\text{RWD}} \geq t_{\text{RWD}} (\text{min})$ ,  $t_{\text{CWD}} \geq t_{\text{CWD}} (\text{min})$ ,  $t_{\text{AWD}} \geq t_{\text{AWD}} (\text{min})$  and  $t_{\text{CPW}} \geq t_{\text{CPW}} (\text{min})$ , the cycle is a read-modify-write and the data output will contain data read from the selected cell; if neither of the above sets of conditions is satisfied, the condition of the data out (at access time) is indeterminate.
- These parameters are referred to  $\overline{\text{CAS}}$  leading edge in an early write cycle and to  $\overline{\text{WE}}$  leading edge in a delayed write or a read-modify-write cycle.
- $t_{\text{RASC}}$  defines  $\overline{\text{RAS}}$  pulse width in fast page mode cycles.
- Access time is determined by the longer of  $t_{\text{AA}}$  or  $t_{\text{CAC}}$  or  $t_{\text{ACP}}$ .
- After power up pause for 100  $\mu\text{s}$ , then DRAM initialization requires a minimum of eight  $\overline{\text{RAS}}$  only refresh or eight  $\overline{\text{CAS}}$ -before- $\overline{\text{RAS}}$  refresh cycles. If the user will implement  $\overline{\text{CAS}}$ -before- $\overline{\text{RAS}}$  timing in their system, then the eight initialization cycles MUST be  $\overline{\text{CAS}}$ -before- $\overline{\text{RAS}}$  cycles
- In delayed write or read-modify-write cycles,  $\overline{\text{OE}}$  must disable output buffer prior to applying data to the device.
- Either  $t_{\text{RCH}}$  or  $t_{\text{RRH}}$  must be satisfied for a read cycle.
- The supply voltage with all  $V_{\text{CC}}$  pins must be on the same level. The supply voltage with all  $V_{\text{SS}}$  pins must be on the same level.
- A word of data can be written only when  $\overline{\text{UWE}}$  and  $\overline{\text{LWE}}$  go low at the same time. This implies that early write cycles cannot be combined with delayed write cycles in the same cycles because all data is latched at the fall of the first  $\overline{\text{WE}}$ . In other words, staggering the  $\overline{\text{WE}}$  signals in one cycle is not permitted.
- $t_{\text{RCH}}$ ,  $t_{\text{RRH}}$ ,  $t_{\text{WCS}}$ ,  $t_{\text{RWD}}$ ,  $t_{\text{CWD}}$  and  $t_{\text{AWD}}$  are determined by the earlier falling edge of  $\overline{\text{UWE}}$  and  $\overline{\text{LWE}}$ .
- $t_{\text{WCH}}$  and  $t_{\text{RCS}}$  are determined by the later rising edge of  $\overline{\text{UWE}}$  or  $\overline{\text{LWE}}$ .
- $t_{\text{WP}}$ ,  $t_{\text{RWL}}$ ,  $t_{\text{CWL}}$ ,  $t_{\text{OEH}}$ ,  $t_{\text{DS}}$ ,  $t_{\text{DH}}$  and  $t_{\text{CPW}}$  should be satisfied by both  $\overline{\text{UWE}}$  and  $\overline{\text{LWE}}$ .

## HM514170C, HM51S4170C Series

22. When output buffers are enabled once, sustain the low impedance state until valid data is obtained. When output buffer is turned on and off within a very short time, generally it causes large  $V_{CC}/V_{SS}$  line noise, which causes to degrade  $V_{IH}(\min)/V_{IL}(\max)$  level.
23. If you use distributed CBR refresh mode with 15.6  $\mu\text{s}$  interval in normal read/write cycle, CBR refresh should be executed within 15.6  $\mu\text{s}$  immediately after exiting from and before entering into self refresh mode.
24. If you use  $\overline{\text{RAS}}$  only refresh or CBR burst refresh mode in normal read/write cycle, 1024 cycles of distributed CBR refresh with 15.6  $\mu\text{s}$  interval should be executed within 16 ms immediately after exiting from and before entering into the self refresh mode.
25. Repetitive self refresh mode without refreshing all memory is not allowed. Once you exit from self refresh mode, all memory cells need to be refreshed before re-entering the self refresh mode again.
26.  H or L (H:  $V_{IH}(\min) \leq V_{IN} \leq V_{IH}(\max)$ , L:  $V_{IL}(\min) \leq V_{IN} \leq V_{IL}(\max)$ )  
 Invalid Dout

## Notes concerning $2\overline{W}\overline{E}$ control

Please do not separate the  $\overline{UWE}$  /  $\overline{LWE}$  operation timing intentionally. However skew between  $\overline{UWE}$  /  $\overline{LWE}$  are allowed under the following conditions.

- (1) Each of the  $\overline{UWE}$  /  $\overline{LWE}$  should satisfy the timing specifications individually.
- (2) Different operation mode for upper/lower byte is not allowed; such as following.

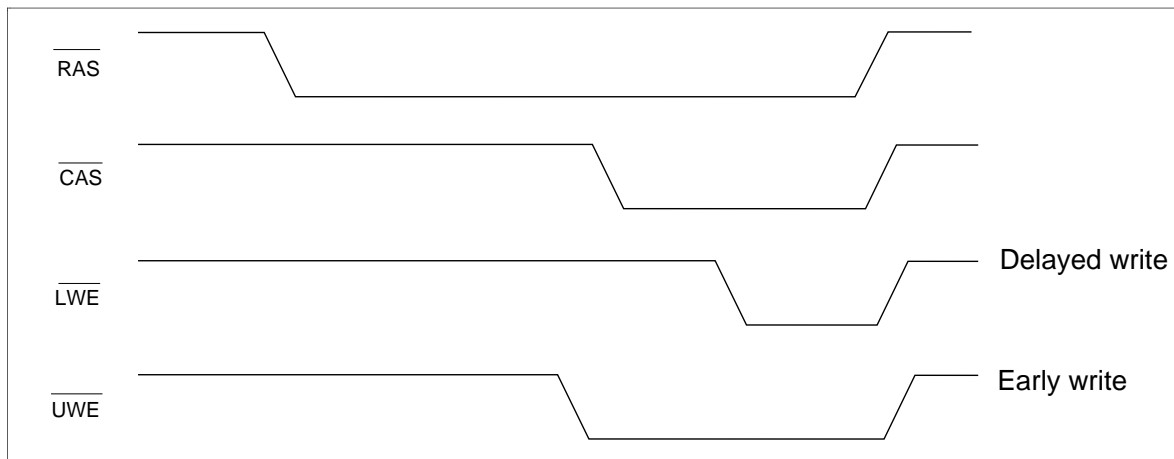

- (3) Closely separated upper/lower byte control is not allowed. Unless the condition ( $t_{CP} \leq t_{UL}$ ) is satisfied.

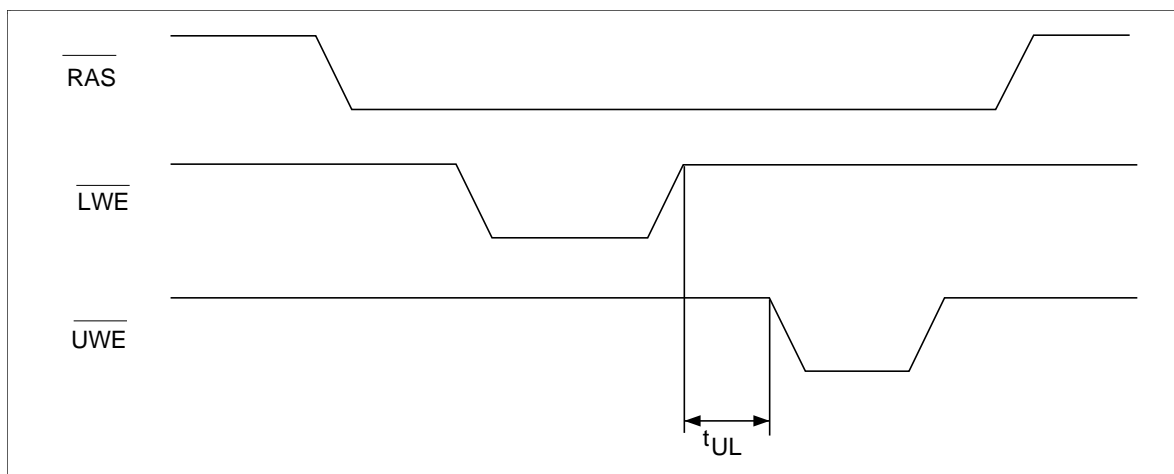

# HM514170C, HM51S4170C Series

## Timing Waveforms <sup>\*26</sup>

### Read Cycle

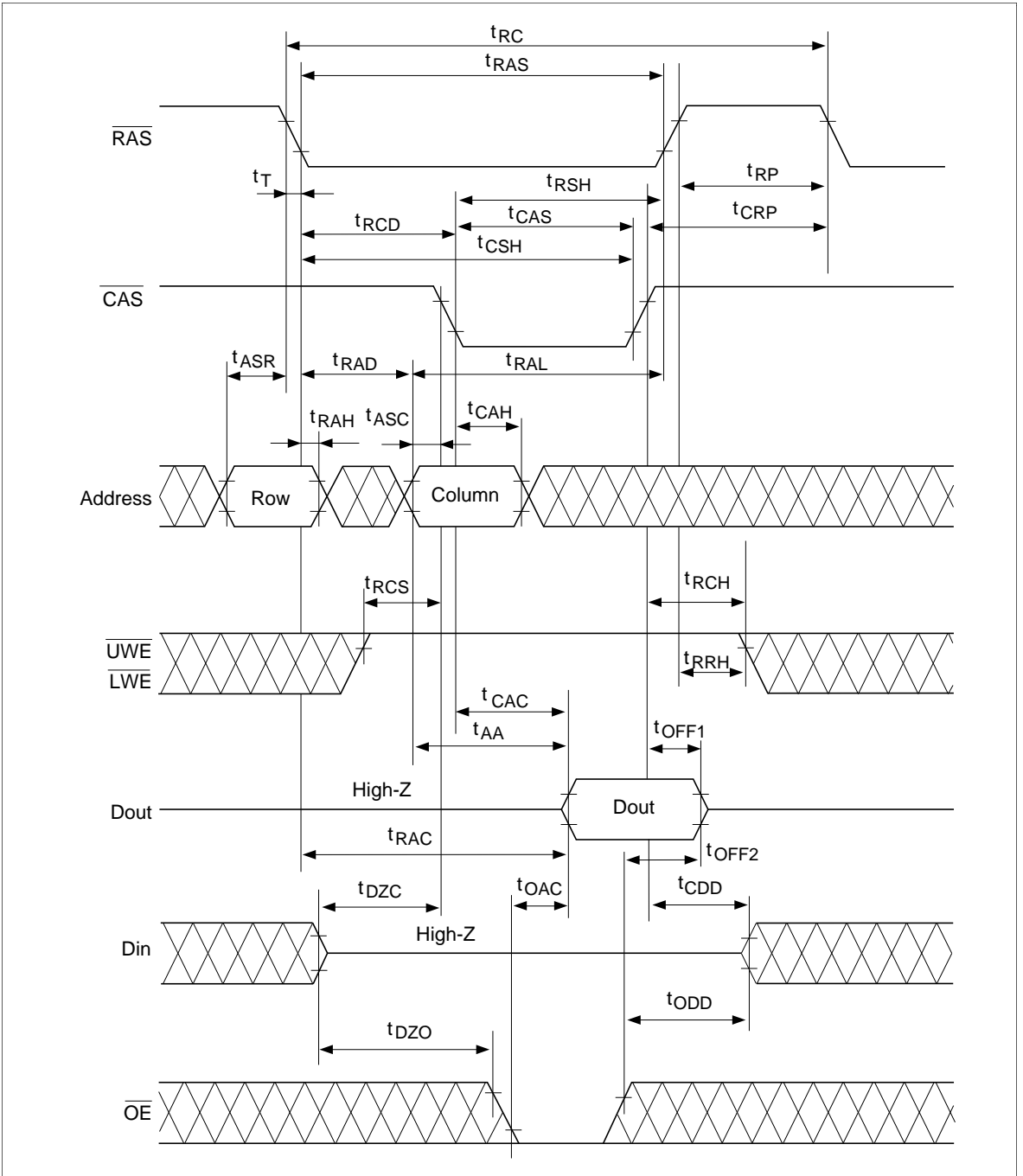

**Early Write Cycle**

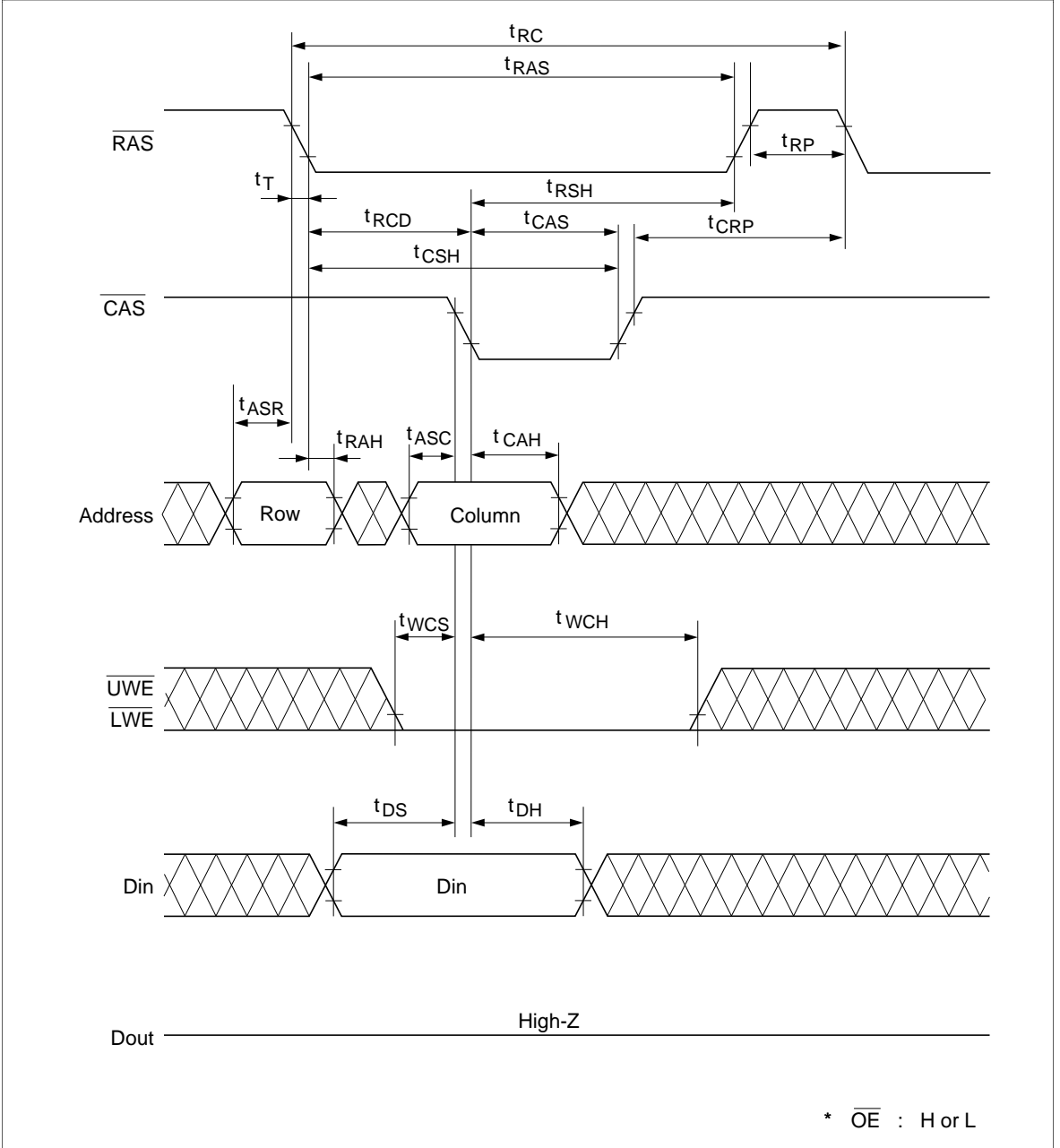

# HM514170C, HM51S4170C Series

## Delayed Write Cycle

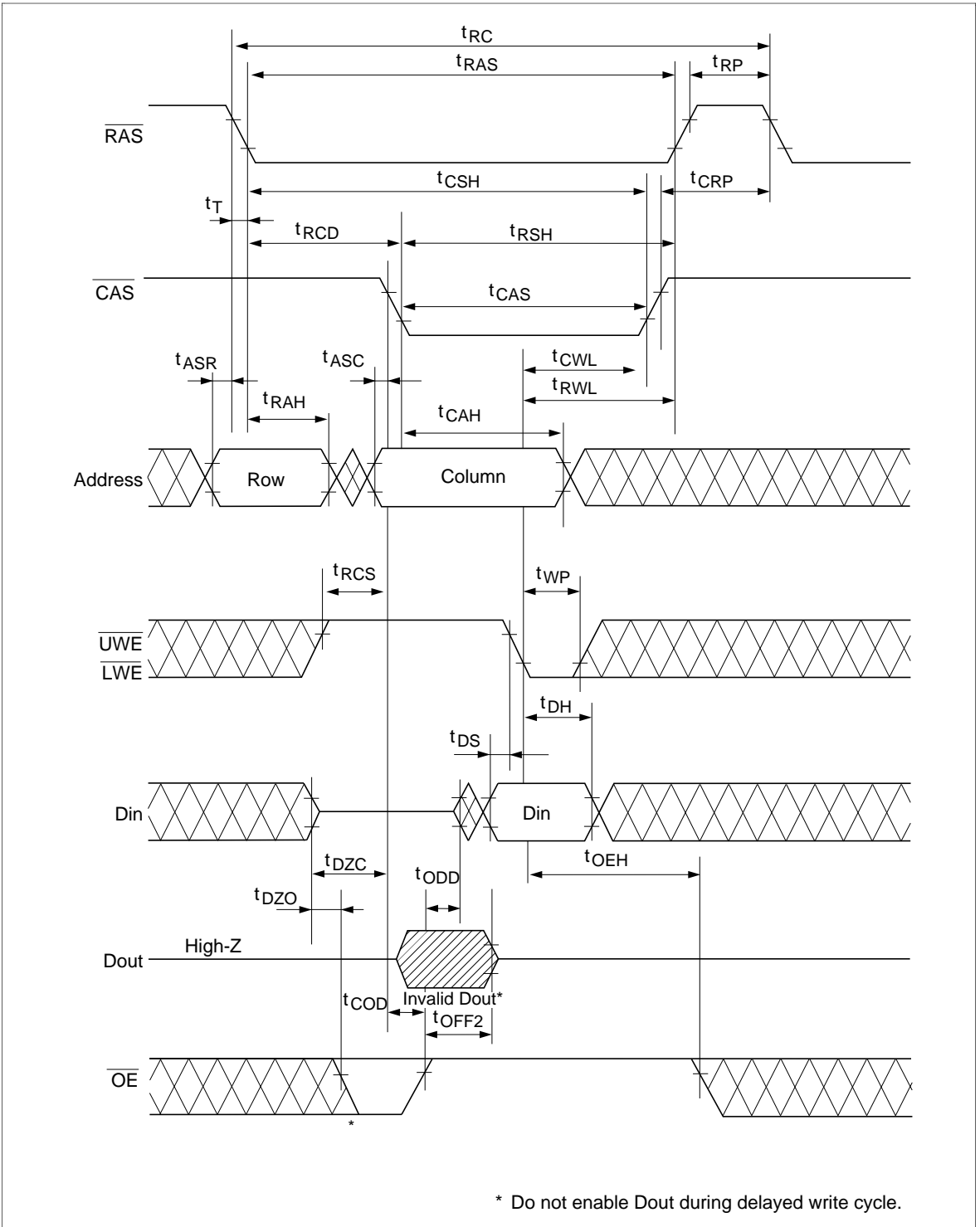

## Read-Modify-Write Cycle



# HM514170C, HM51S4170C Series

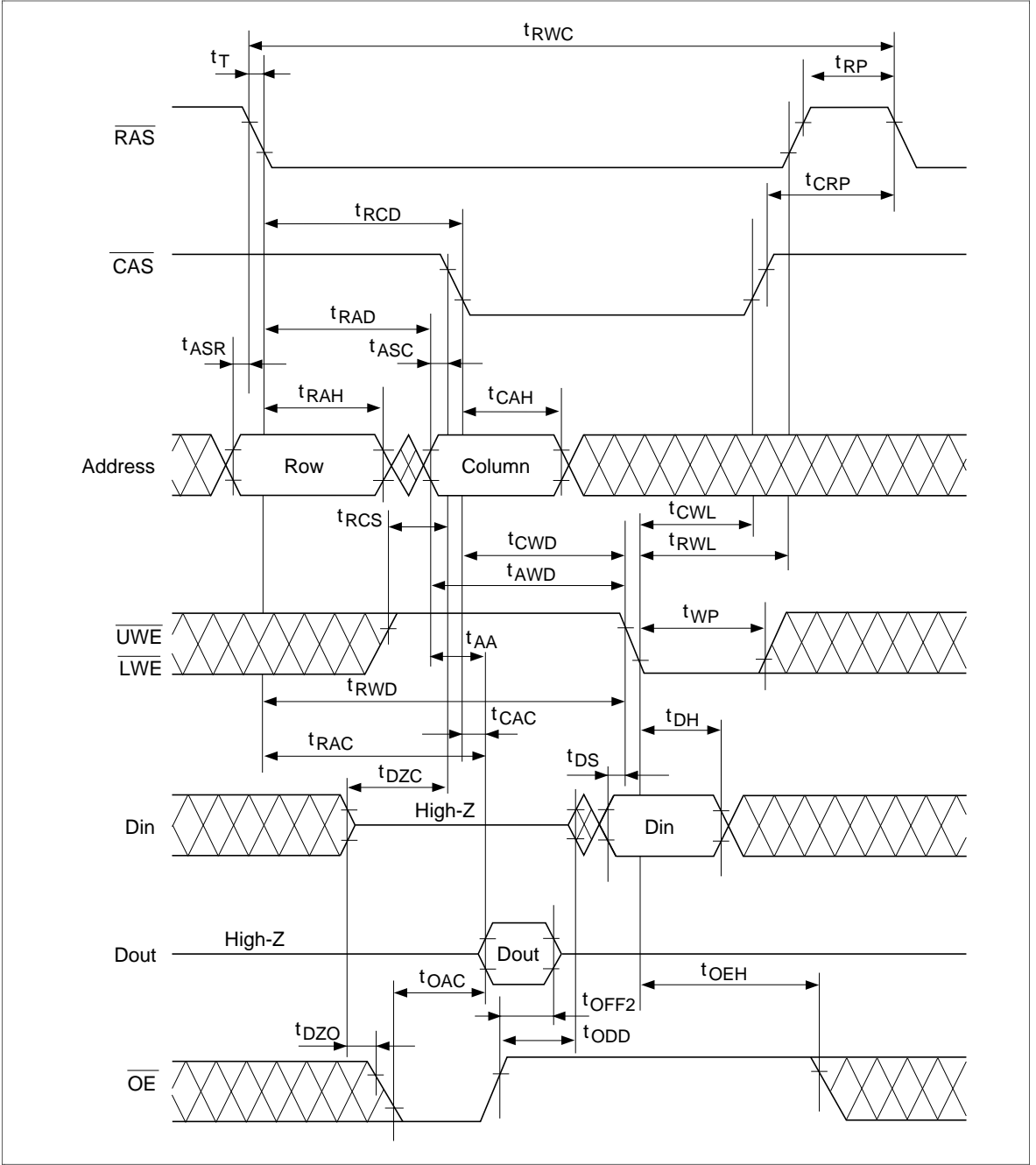

# HM514170C, HM51S4170C Series

## $\overline{\text{RAS}}$ -Only Refresh Cycle

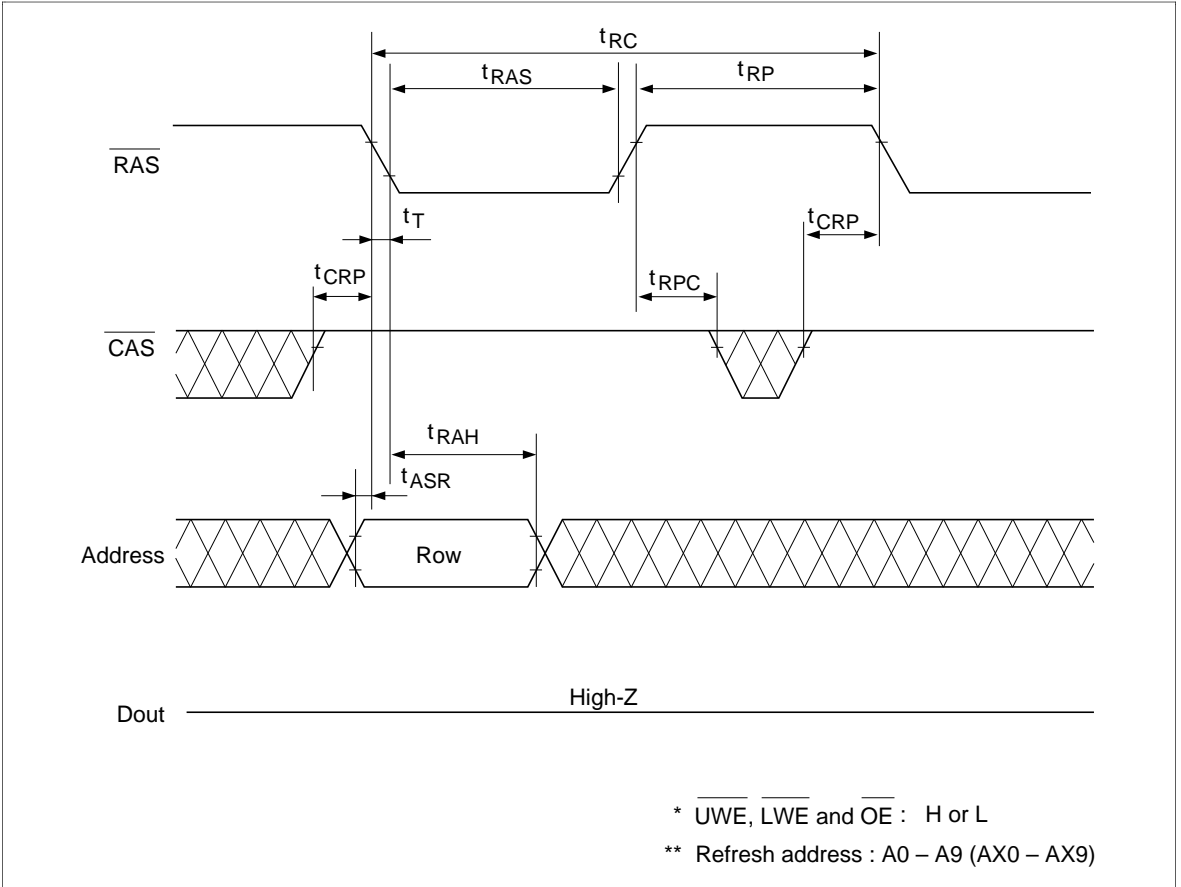

**$\overline{\text{CAS}}$ -Before- $\overline{\text{RAS}}$  Refresh Cycle**

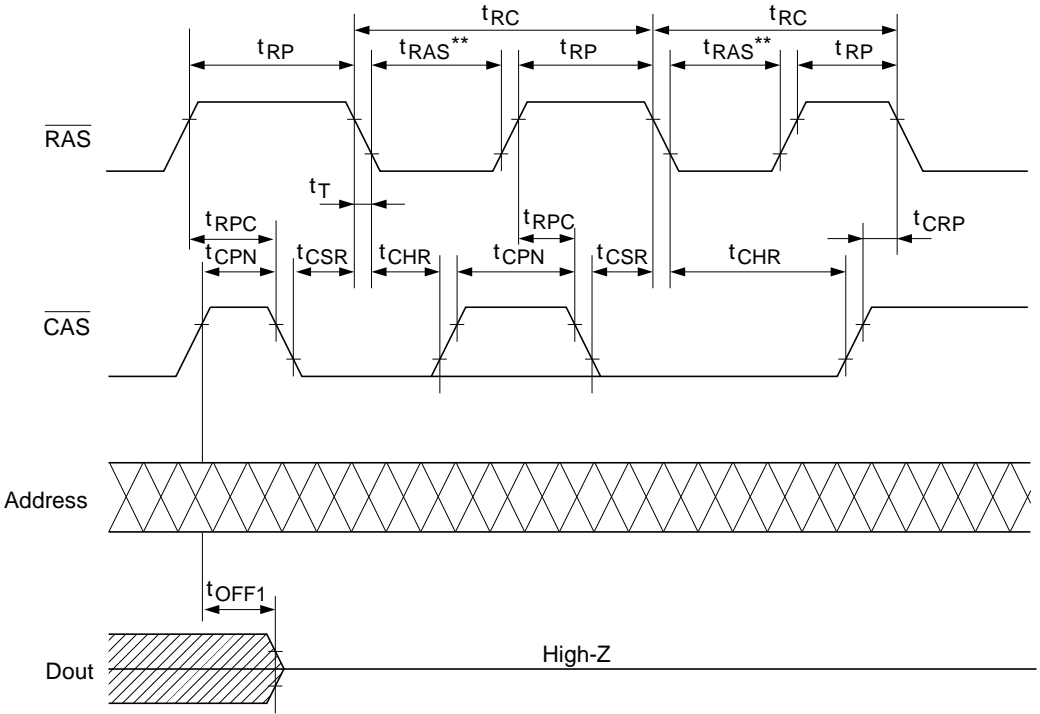

\*  $\overline{\text{UWE}}$ ,  $\overline{\text{LWE}}$  : H or L

\*\* Do not extend  $t_{RAS} \geq t_{RAS}(\text{max})$ .  
 Untested self refresh mode may be activated and loss of data may be resulted.  
 (HM514170C)



**Fast Page Mode Early Write Cycle**

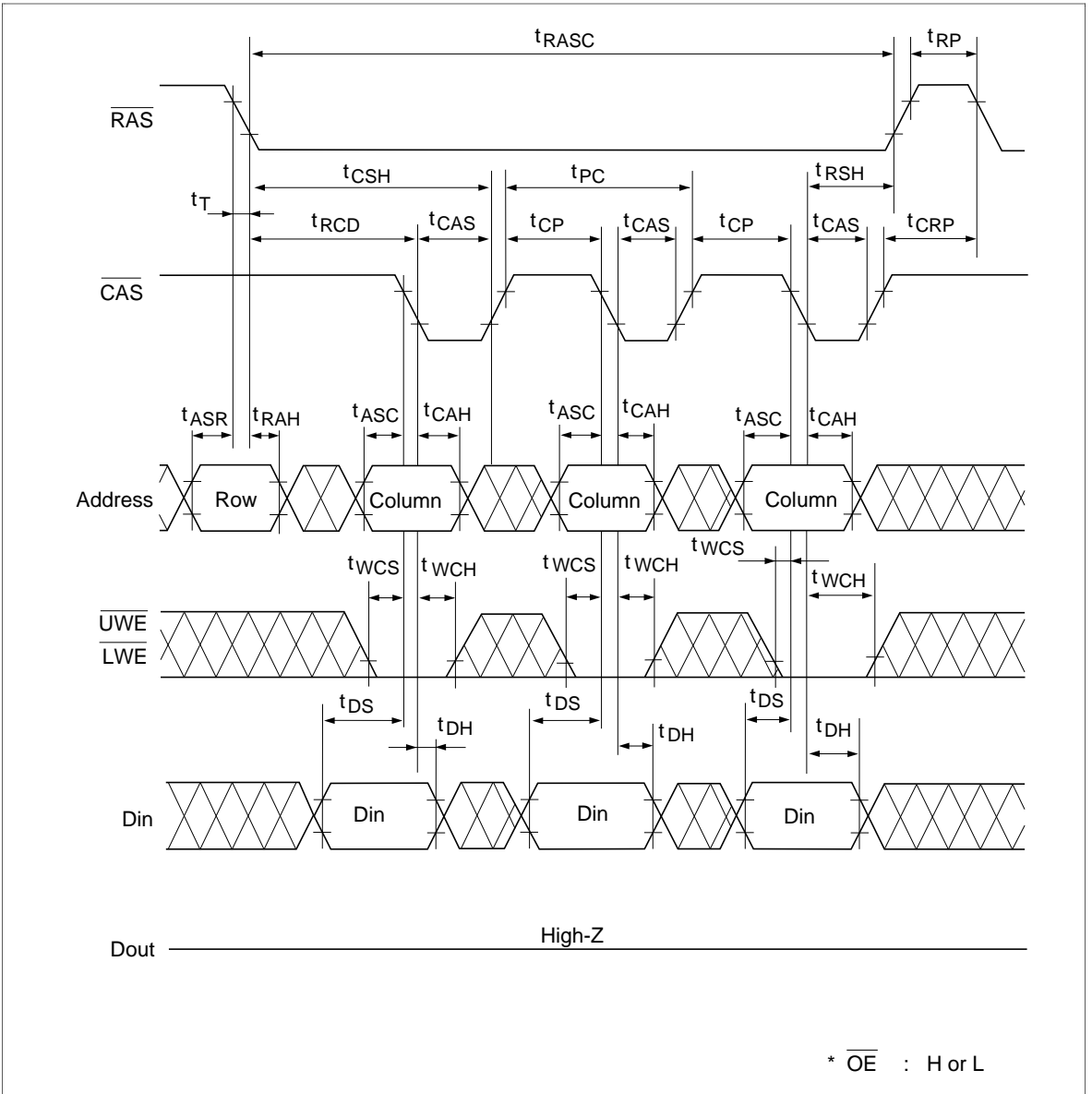

# HM514170C, HM51S4170C Series

## Fast Page Mode Delayed Write Cycle

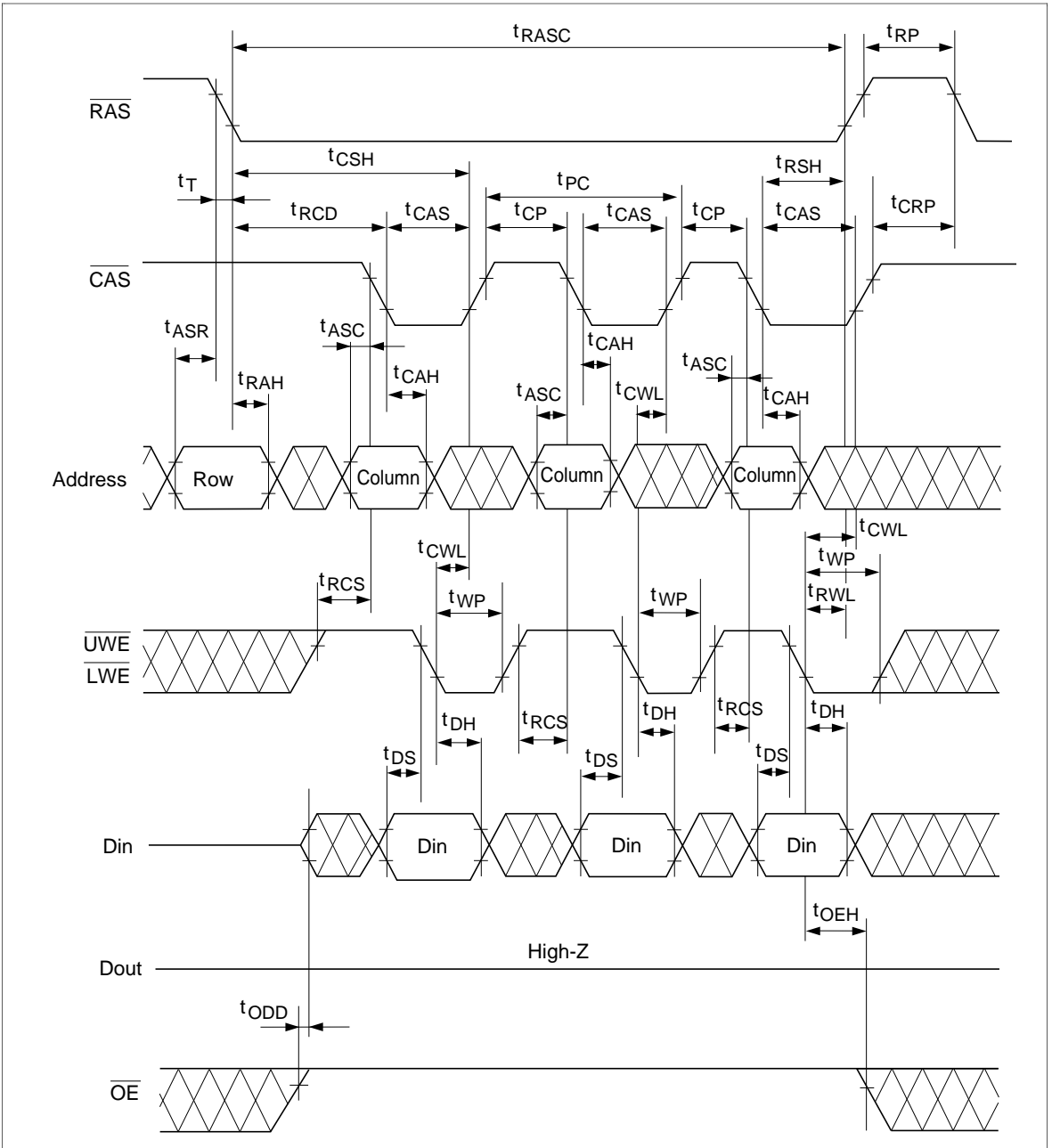

Fast Page Mode Read-Modify-Write Cycle

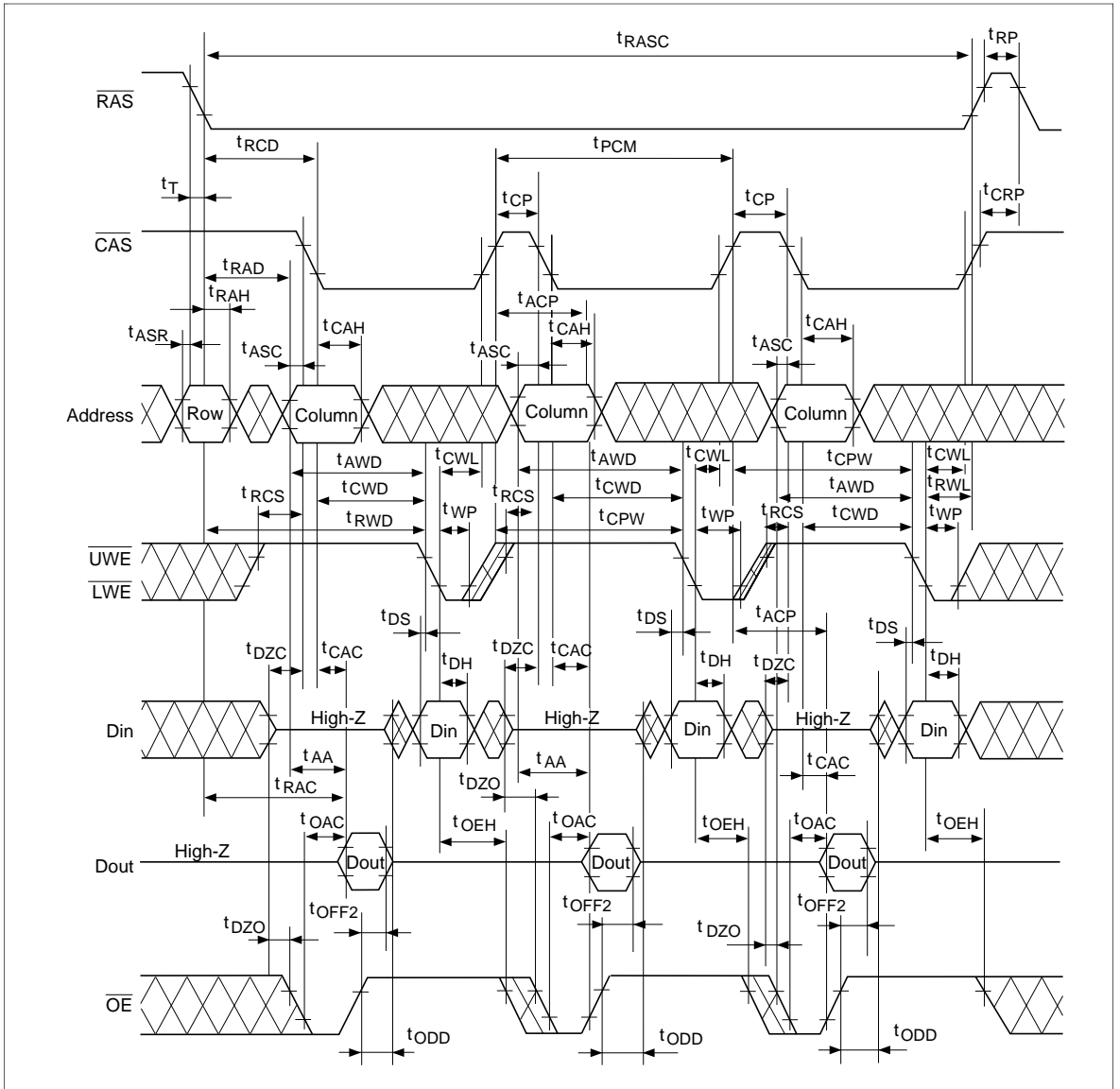





**Package Dimensions**

**HM51(S)4170CJ/CLJ Series (CP-40DA)**

Unit: mm

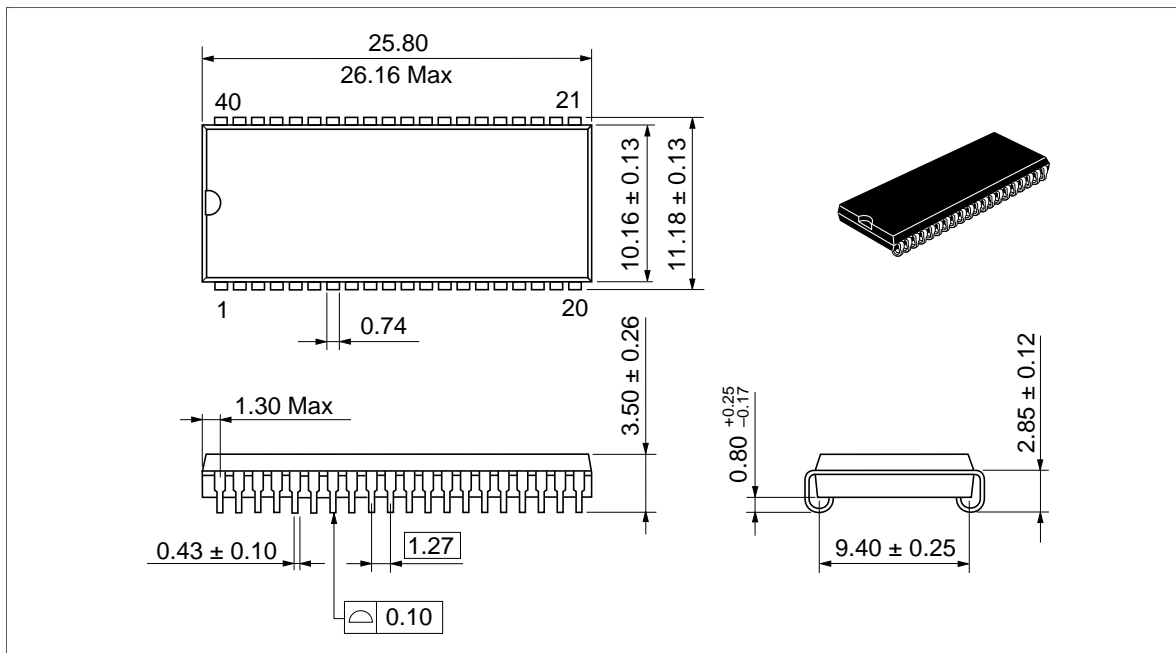

# HM514170C, HM51S4170C Series

HM51(S)4170CTT/CLTT Series (TTP-44/40DB)

Unit: mm

