



HM64YLB36514 Series

16M Synchronous Late Write Fast Static RAM
(512-kword × 36-bit, Register-Latch Mode)

REJ03C0039-0001Z

Preliminary

Rev.0.10

May.15.2003

Description

The HM64YLB36514 is a synchronous fast static RAM organized as 512-kword × 36-bit. It has realized high speed access time by employing the most advanced CMOS process and high speed circuit designing technology. It is most appropriate for the application which requires high speed, high density memory and wide bit width configuration, such as cache and buffer memory in system. It is packaged in standard 119-bump BGA.

Note: All power supply and ground pins must be connected for proper operation of the device.

Features

- 2.5 V ± 5% operation and 1.5 V (V_{DDQ})
- 16M bit density
- Internal self-timed late write
- Byte write control (4 byte write selects, one for each 9-bit)
- Optional ×18 configuration
- HSTL compatible I/O
- Programmable impedance output drivers
- Differential pseudo-HSTL clock inputs
- Asynchronous \overline{G} output control
- Asynchronous sleep mode
- FC-BGA 119pin package with SRAM JEDEC standard pinout
- Limited set of boundary scan JTAG IEEE 1149.1 compatible
- Protocol: Single differential clock register-latch mode

Preliminary: The specifications of this device are subject to change without notice. Please contact your nearest Renesas Technology's Sales Dept. regarding specifications.

HM64YLB36514 Series

Ordering Information

Type No.	Organization	Access time	Cycle time	Package
HM64YLB36514BP-6H	512k × 36	5.5 ns	6.5 ns	119-bump 1.27 mm 14 mm × 22 mm BGA (BP-119E)

Pin Arrangement

	1	2	3	4	5	6	7
A	V_{DDQ}	SA14	SA13	NC	SA6	SA7	V_{DDQ}
B	NC	SA15	SA12	NC	SA5	SA9	NC
C	NC	SA16	SA11	V_{DD}	SA4	SA8	NC
D	DQc7	DQc8	V_{SS}	ZQ	V_{SS}	DQb8	DQb7
E	DQc5	DQc6	V_{SS}	\overline{SS}	V_{SS}	DQb6	DQb5
F	V_{DDQ}	DQc4	V_{SS}	\overline{G}	V_{SS}	DQb4	V_{DDQ}
G	DQc3	DQc2	\overline{SWEc}	NC	\overline{SWEb}	DQb2	DQb3
H	DQc1	DQc0	V_{SS}	NC	V_{SS}	DQb0	DQb1
J	V_{DDQ}	V_{DD}	V_{REF}	V_{DD}	V_{REF}	V_{DD}	V_{DDQ}
K	DQd1	DQd0	V_{SS}	K	V_{SS}	DQa0	DQa1
L	DQd3	DQd2	\overline{SWEd}	\overline{K}	\overline{SWEa}	DQa2	DQa3
M	V_{DDQ}	DQd4	V_{SS}	\overline{SWE}	V_{SS}	DQa4	V_{DDQ}
N	DQd5	DQd6	V_{SS}	SA17	V_{SS}	DQa6	DQa5
P	DQd7	DQd8	V_{SS}	SA0	V_{SS}	DQa8	DQa7
R	NC	SA10	M1	V_{DD}	M2	SA1	NC
T	NC	NC	SA18	SA3	SA2	NC	ZZ
U	V_{DDQ}	TMS	TDI	TCK	TDO	NC	V_{DDQ}

(Top view)

Block Diagram

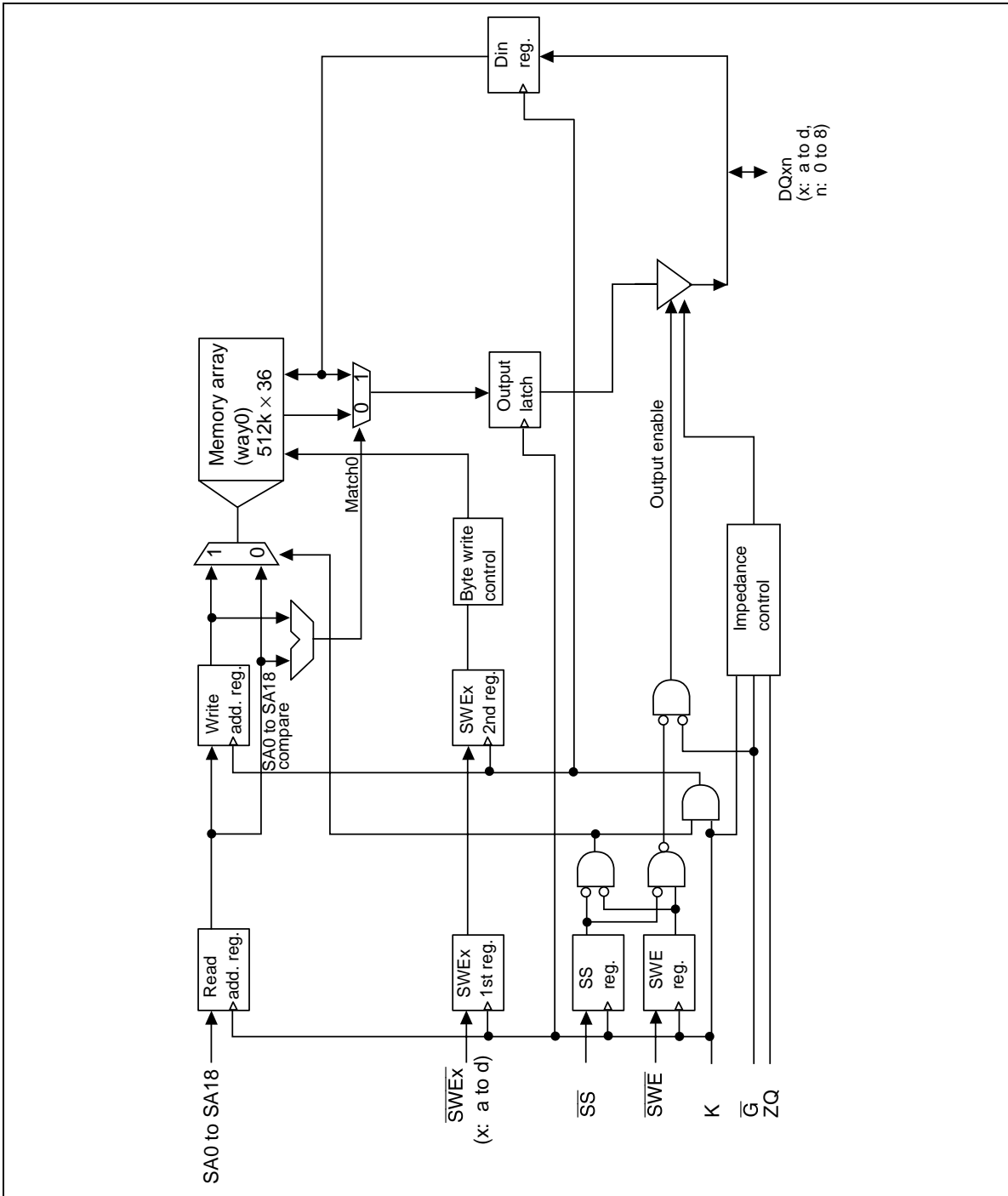

HM64YLB36514 Series

Pin Descriptions

Name	I/O type	Descriptions	Notes
V_{DD}	Supply	Core power supply	
V_{SS}	Supply	Ground	
V_{DDQ}	Supply	Output power supply	
V_{REF}	Supply	Input reference, provides input reference voltage	
K	Input	Clock input, active high	
\bar{K}	Input	Clock input, active low	
\bar{SS}	Input	Synchronous chip select	
\bar{SWE}	Input	Synchronous write enable	
SAn	Input	Synchronous address input	n: 0 to 18
$\bar{SWE}x$	Input	Synchronous byte write enables	x: a to d
\bar{G}	Input	Asynchronous output enable	
ZZ	Input	Power down mode select	
ZQ	Input	Output impedance control	1
DQxn	I/O	Synchronous data input/output	x: a to d n: 0 to 8
M1, M2	Input	Output protocol mode select	
TMS	Input	Boundary scan test mode select	
TCK	Input	Boundary scan test clock	
TDI	Input	Boundary scan test data input	
TDO	Output	Boundary scan test data output	
NC	—	No connection	

M1	M2	Protocol	Notes
V_{DD}	V_{SS}	Synchronous register to latch operation	2

- Notes:
1. ZQ is to be connected to V_{SS} via a resistance RQ where $175 \Omega \leq RQ \leq 300 \Omega$. If ZQ = V_{DDQ} or open, output buffer impedance will be maximum.
 2. There is 1 protocol with mode control input pins (M1, M2). These mode pins are to be tied either V_{DD} or V_{SS} respectively. These mode pins are set at power-up and will not change the states during the SRAM operates. This SRAM is tested only in the synchronous register to latch operation.

HM64YLB36514 Series

Truth Table

ZZ	SS	\bar{G}	\overline{SWE}	\overline{SWEa}	\overline{SWEb}	\overline{SWEc}	\overline{SWEd}	K	\bar{K}	Operation	DQ (n)	DQ (n+1)
H	x	x	x	x	x	x	x	x	x	Sleep mode	High-Z	High-Z
L	H	x	x	x	x	x	x	L-H	H-L	Dead (not selected)	High-Z	x
L	x	H	H	x	x	x	x	x	x	Dead (dummy read)	High-Z	High-Z
L	L	L	H	x	x	x	x	L-H	H-L	Read	D _{OUT} (a, b, c, d) 0 to 8	x
L	L	x	L	L	L	L	L	L-H	H-L	Write a, b, c, d byte	High-Z	D _{IN} (a, b, c, d) 0 to 8
L	L	x	L	H	L	L	L	L-H	H-L	Write b, c, d byte	High-Z	D _{IN} (b, c, d) 0 to 8
L	L	x	L	L	H	L	L	L-H	H-L	Write a, c, d byte	High-Z	D _{IN} (a, c, d) 0 to 8
L	L	x	L	L	L	H	L	L-H	H-L	Write a, b, d byte	High-Z	D _{IN} (a, b, d) 0 to 8
L	L	x	L	L	L	L	H	L-H	H-L	Write a, b, c byte	High-Z	D _{IN} (a, b, c) 0 to 8
L	L	x	L	H	H	L	L	L-H	H-L	Write c, d byte	High-Z	D _{IN} (c, d) 0 to 8
L	L	x	L	L	H	H	L	L-H	H-L	Write a, d byte	High-Z	D _{IN} (a, d) 0 to 8
L	L	x	L	L	L	H	H	L-H	H-L	Write a, b byte	High-Z	D _{IN} (a, b) 0 to 8
L	L	x	L	H	L	L	H	L-H	H-L	Write b, c byte	High-Z	D _{IN} (b, c) 0 to 8
L	L	x	L	H	H	H	L	L-H	H-L	Write d byte	High-Z	D _{IN} (d) 0 to 8
L	L	x	L	H	H	L	H	L-H	H-L	Write c byte	High-Z	D _{IN} (c) 0 to 8
L	L	x	L	H	L	H	H	L-H	H-L	Write b byte	High-Z	D _{IN} (b) 0 to 8
L	L	x	L	L	H	H	H	L-H	H-L	Write a byte	High-Z	D _{IN} (a) 0 to 8

Notes: 1. H: V_{IH}, L: V_{IL}, x: V_{IH} or V_{IL}

2. \overline{SWE} , SS, \overline{SWEa} to \overline{SWEd} , and SA are sampled at the rising edge of K clock.

Programmable Impedance Output Drivers

Output buffer impedance can be programmed by terminating the ZQ pin to V_{SS} through a precision resistor (RQ). The value of RQ is five times the output impedance desired. The allowable value of RQ to guarantee impedance matching with a tolerance of 15% is 250 Ω . If the status of ZQ pin is open, output impedance is maximum value. Maximum impedance also occurs with ZQ connected to V_{DDQ} . The impedance update of the output driver occurs when the SRAM is in high-Z. Write and deselect operations will synchronously switch the SRAM into and out of high-Z, therefore will trigger an update. The user may choose to invoke asynchronous \overline{G} updates by providing a \overline{G} setup and hold about the K clock, to guarantee the proper update. At power up, the output buffer is in high-Z. It will take 4,096 cycles for the impedance to be completely updated.

Absolute Maximum Ratings

Parameter	Symbol	Rating	Unit	Notes
Input voltage on any pin	V_{IN}	-0.5 to $V_{DDQ} + 0.5$	V	1, 4
Core supply voltage	V_{DD}	-0.5 to +3.13	V	1
Output supply voltage	V_{DDQ}	-0.5 to +2.1	V	1, 4
Operating temperature	T_{OPR}	0 to +85	°C	
Storage temperature	T_{STG}	-55 to +125	°C	
Output short-circuit current	I_{OUT}	25	mA	
Latch up current	I_{LI}	200	mA	
Package junction to top thermal resistance	θ_{J-top}	6.5	°C/W	5
Package junction to board thermal resistance	$\theta_{J-board}$	12	°C/W	5

- Notes:
1. All voltage is referenced to V_{SS} .
 2. Permanent device damage may occur if absolute maximum ratings are exceeded. Functional operation should be restricted the operation conditions. Exposure to higher voltages than recommended voltages for extended periods of time could affect device reliability.
 3. These CMOS memory circuits have been designed to meet the DC and AC specifications shown in the tables after thermal equilibrium has been established.
 4. The following supply voltage application sequence is recommended: V_{SS} , V_{DD} , V_{DDQ} , V_{REF} then V_{IN} . Remember, according to the absolute maximum ratings table, V_{DDQ} is not to exceed 2.1 V, whatever the instantaneous value of V_{DDQ} .
 5. See figure below.

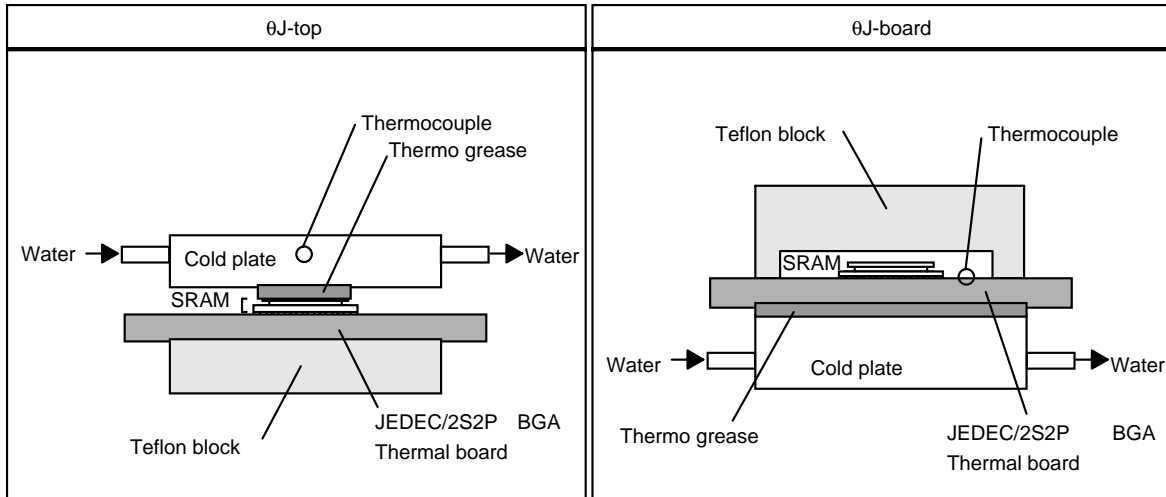

HM64YLB36514 Series

Note: The following DC and AC specifications shown in the tables, this device is tested under the minimum transverse air flow exceeding 500 linear feet per minute.

Recommended DC Operating Conditions (Ta = 0 to +85°C)

Parameter	Symbol	Min	Typ	Max	Unit	Notes
Power supply voltage: core	V_{DD}	2.38	2.50	2.63	V	
Power supply voltage: I/O	V_{DDQ}	1.40	1.50	1.60	V	
Input reference voltage: I/O	V_{REF}	0.70	0.75	0.80	V	1
Input high voltage	V_{IH}	$V_{REF} + 0.15$	—	$V_{DDQ} + 0.50$	V	4
Input low voltage	V_{IL}	-0.50	—	$V_{REF} - 0.15$	V	4
Clock differential voltage	V_{DIF}	0.10	—	$V_{DDQ} + 0.30$	V	2, 3
Clock common mode voltage	V_{CM}	0.90	—	1.30	V	3

- Notes:
1. Peak to peak AC component superimposed on V_{REF} may not exceed 5% of V_{REF} .
 2. Minimum differential input voltage required for differential input clock operation.
 3. See figure below.
 4. $V_{REF} = 0.75$ V (typ).

Differential Voltage / Common Mode Voltage

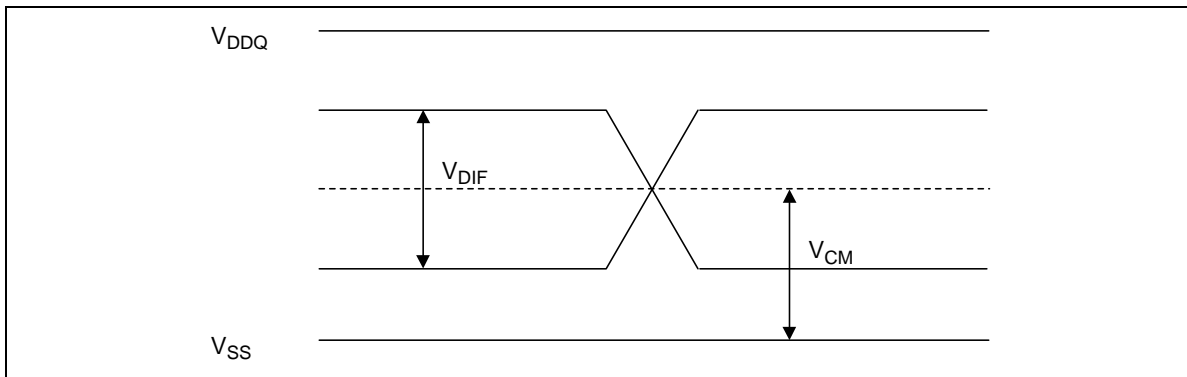

HM64YLB36514 Series

DC Characteristics (Ta = 0 to +85°C, V_{DD} = 2.5 V ± 5%)

Parameter	Symbol	Min	Max	Unit	Notes
Input leakage current	I _{LI}	—	2	μA	1
Output leakage current	I _{LO}	—	5	μA	2
Standby current	I _{SBZZ}	—	150	mA	3
V _{DD} operating current, excluding output drivers	I _{DD}	—	350	mA	4
Quiescent active power supply current	I _{DD2}	—	200	mA	5
Maximum power dissipation, including output drivers	P	—	2.3	W	6

Parameter	Symbol	Min	Typ	Max	Unit	Notes
Output low voltage	V _{OL}	V _{SS}	—	V _{SS} + 0.4	V	7
Output high voltage	V _{OH}	V _{DDQ} - 0.4	—	V _{DDQ}	V	8
ZQ pin connect resistance	RQ	—	250	—	Ω	
Output "Low" current	I _{OL}	(V _{DDQ} /2)/{(RQ/5) - 15%}	—	(V _{DDQ} /2)/{(RQ/5) + 15%}	mA	9, 11
Output "High" current	I _{OH}	(V _{DDQ} /2)/{(RQ/5) + 15%}	—	(V _{DDQ} /2)/{(RQ/5) - 15%}	mA	10, 11

- Notes:
1. $0 \leq V_{IN} \leq V_{DDQ}$ for all input pins (except V_{REF}, ZQ, M1, M2 pin)
 2. $0 \leq V_{OUT} \leq V_{DDQ}$, DQ in high-Z
 3. All inputs (except clock) are held at either V_{IH} or V_{IL}, ZZ is held at V_{IH}, I_{OUT} = 0 mA. Specification is guaranteed at +75°C junction temperature.
 4. I_{OUT} = 0 mA, read 50% / write 50%, V_{DD} = V_{DD} max, frequency = min. cycle
 5. I_{OUT} = 0 mA, read 50% / write 50%, V_{DD} = V_{DD} max, frequency = 3 MHz
 6. Output drives a 12 pF load and switches every cycle. This parameter should be used by the SRAM designer to determine electrical and package requirements for the SRAM device.
 7. RQ = 250 Ω, I_{OL} = 6.8 mA
 8. RQ = 250 Ω, I_{OH} = -6.8 mA
 9. Measured at V_{OL} = 1/2 V_{DDQ}
 10. Measured at V_{OH} = 1/2 V_{DDQ}
 11. The total external capacitance of ZQ pin must be less than 7.5 pF.

HM64YLB36514 Series

AC Characteristics (T_a = 0 to +85°C, V_{DD} = 2.5 V ± 5%)

Single Differential Clock Register-Latch Mode

Parameter	Symbol	HM64YLB36514BP		Unit	Notes
		Min	Max		
CK clock cycle time	t _{KHKH}	6.5	—	ns	
CK clock high width	t _{KHKL}	1.2	—	ns	
CK clock low width	t _{KLKH}	1.2	—	ns	
Address setup time	t _{AVKH}	0.4	—	ns	2
Data setup time	t _{DVKH}	0.4	—	ns	2
Address hold time	t _{KHAX}	1.0	—	ns	
Data hold time	t _{KHDX}	1.0	—	ns	
Clock high to output valid	t _{KHQV}	1.7	5.5	ns	1
Clock low to output valid	t _{KLQV}	0.5	2.3	ns	
Clock low to output hold	t _{KLQX}	0.5	—	ns	
Clock low to output low-Z (SS control)	t _{KLQX2}	0.5	—	ns	1, 4, 6
Clock high to output high-Z	t _{KHQZ}	0.5	2.3	ns	1, 3, 6
Output enable low to output low-Z	t _{GLQX}	0.1	—	ns	1, 4, 6
Output enable low to output valid	t _{GLQV}	—	2.3	ns	1, 4
Output enable high to output high-Z	t _{GHOZ}	—	2.3	ns	1, 3
Sleep mode recovery time	t _{ZZR}	20.0	—	ns	5
Sleep mode enable time	t _{ZZE}	—	15.0	ns	1, 3, 5

Notes: 1. See figure in "AC Test Conditions".

2. Parameters may be guaranteed by design, i.e., without tester guardband.
3. Transitions are measured ±50 mV of output high impedance from output low impedance.
4. Transitions are measured ±50 mV from steady state voltage.
5. When ZZ is switching, clock input K must be at the same logic level for the reliable operation.
6. Minimum value is verified by design and tested without guardband.

Timing Waveforms

Read Cycle-1

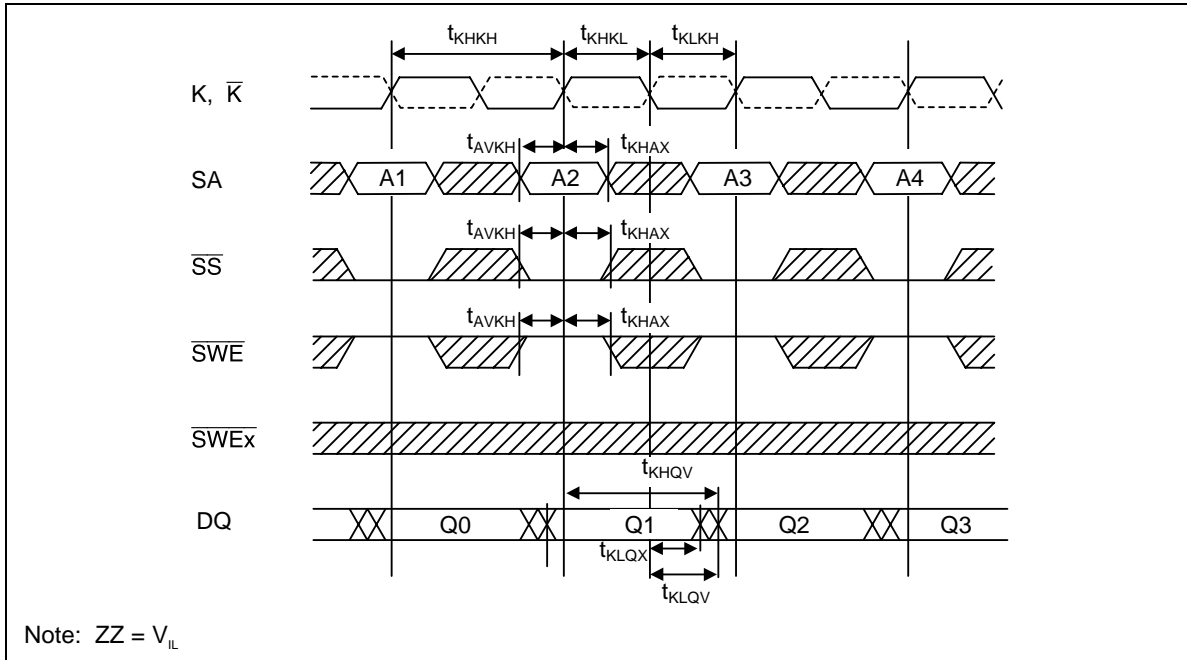

Read Cycle-2 (\overline{SS} Controlled)

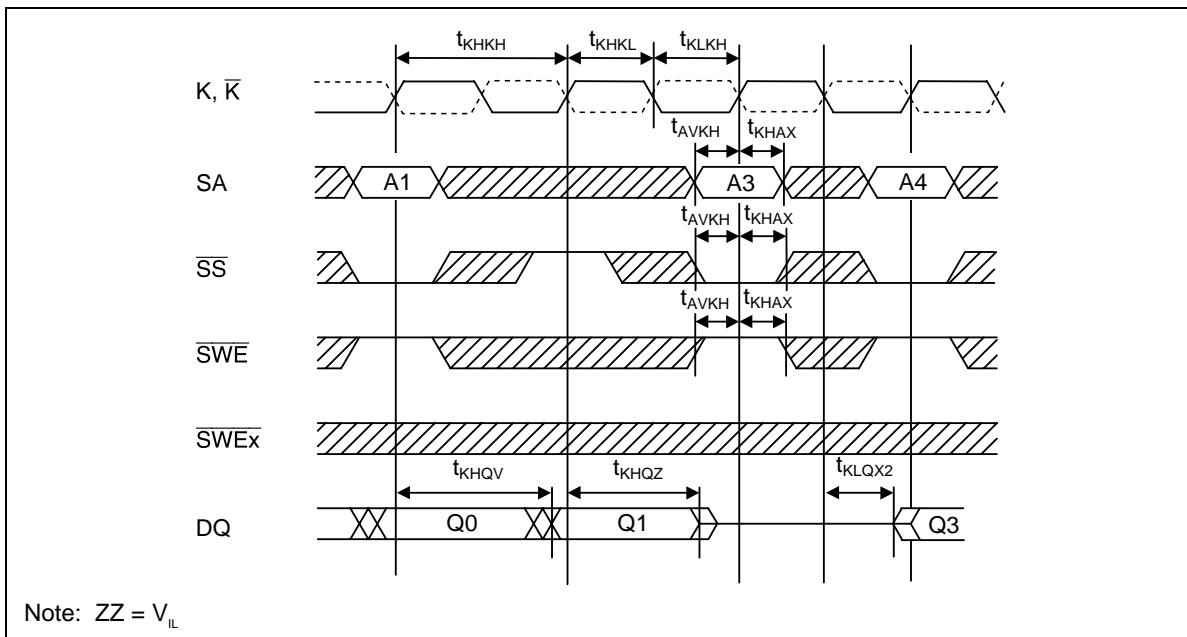

Read Cycle-3 (\overline{G} Controlled)

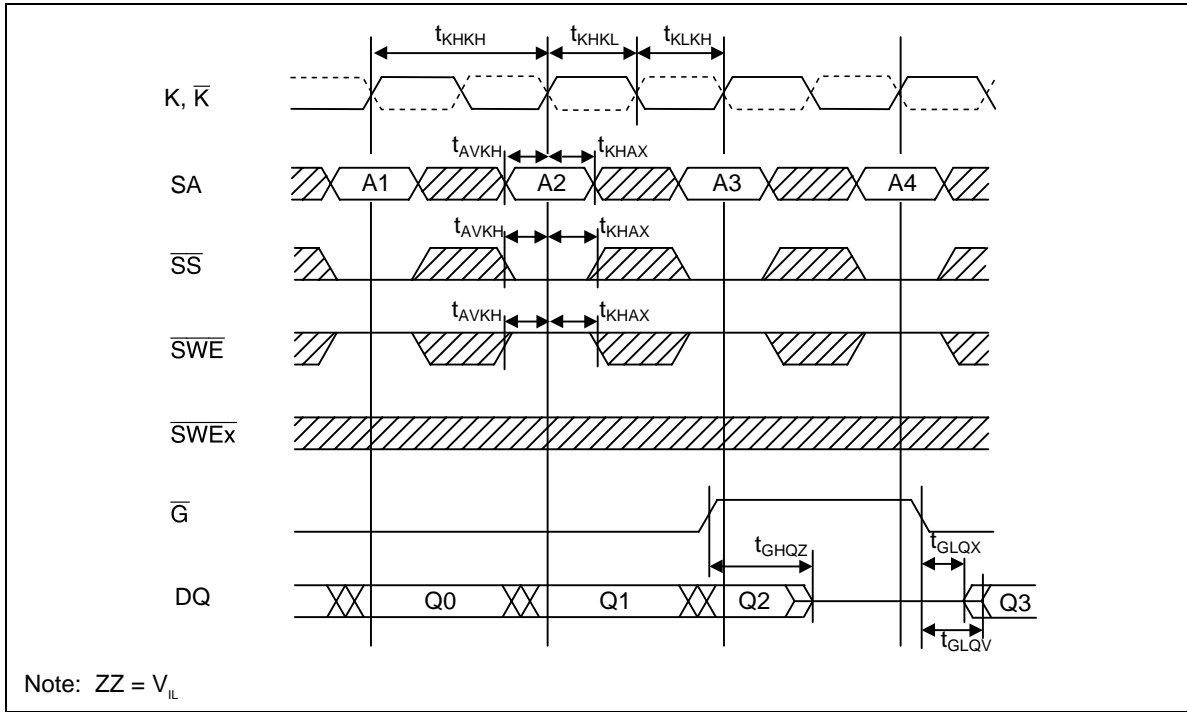

Write Cycle

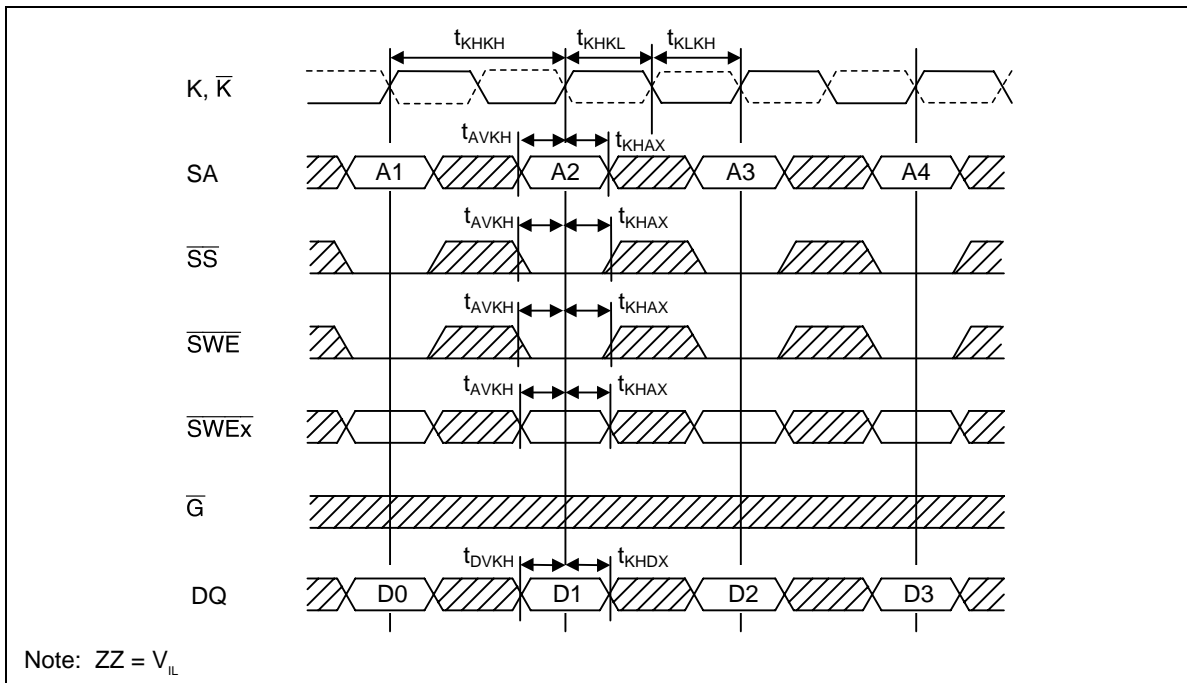

Read-Write Cycle-1

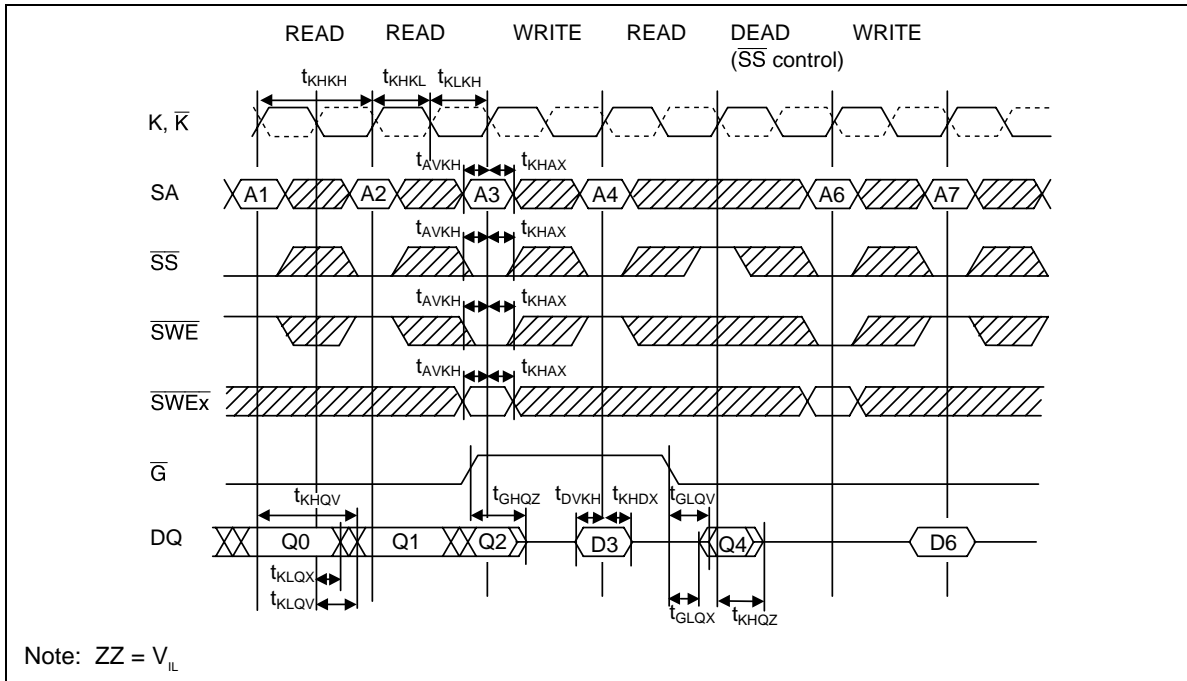

Read-Write Cycle-2

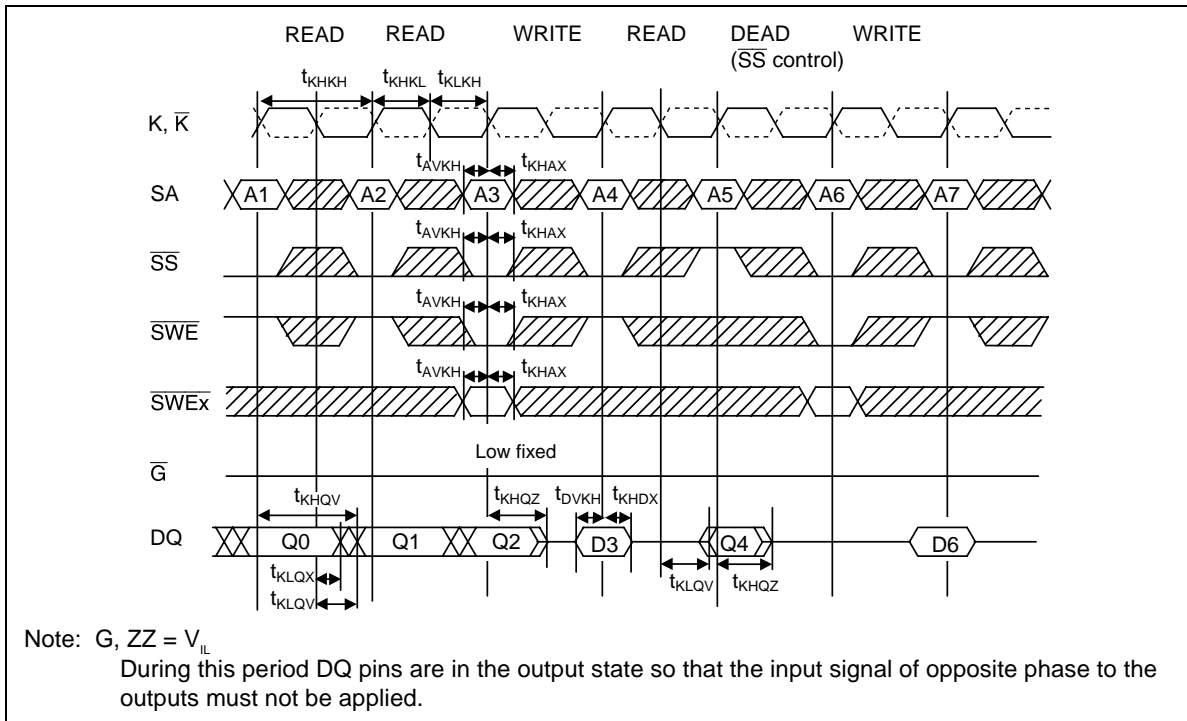

ZZ Control

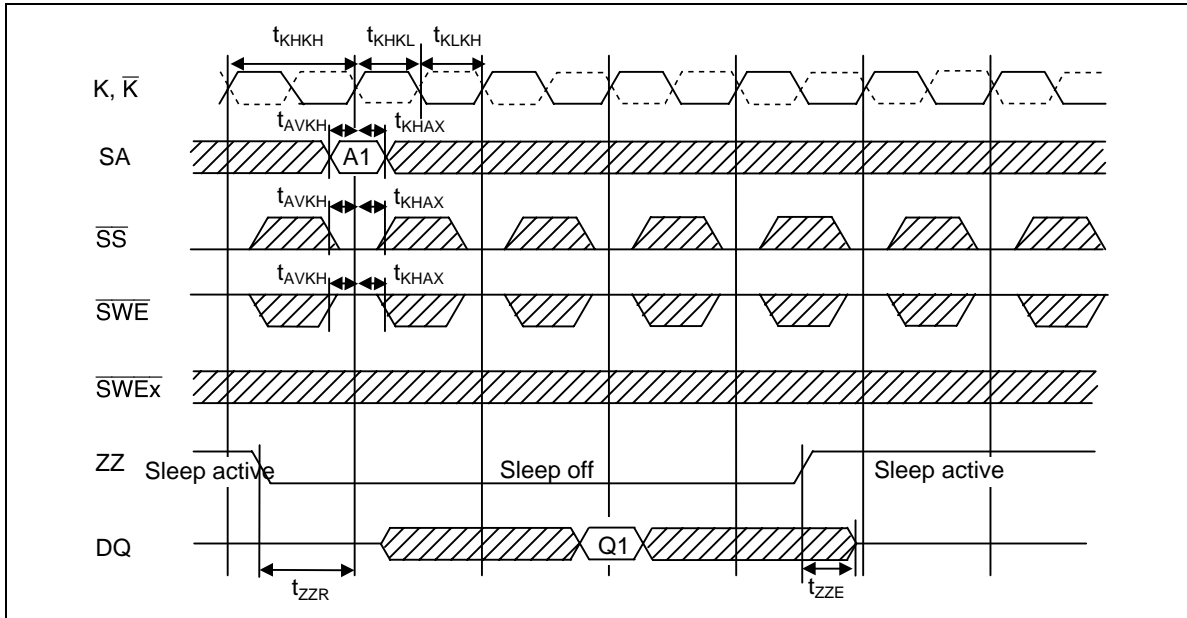

HM64YLB36514 Series

Input Capacitance ($V_{DD} = 2.5\text{ V}$, $V_{DDQ} = 1.5\text{ V}$, $T_a = +25^\circ\text{C}$, $f = 1\text{ MHz}$)

Parameter	Symbol	Min	Max	Unit	Pin name	Notes
Input capacitance	C_{IN}	—	4	pF	SAn, SS, SWE, SWEx	1, 3
Clock input capacitance	C_{CLK}	—	5	pF	K, \bar{K}	1, 2, 3
I/O capacitance	C_{IO}	—	5	pF	DQxn	1, 3

- Notes:
1. This parameter is sampled and not 100% tested.
 2. Exclude \bar{G}
 3. Connect pins to GND, except V_{DD} , V_{DDQ} , and the measured pin.

AC Test Conditions

Parameter	Symbol	Conditions	Unit	Note
Input and output timing reference levels	V_{REF}	0.75	V	
Input signal amplitude	V_{IL} , V_{IH}	0.25 to 1.25	V	
Input rise / fall time	tr, tf	0.5 (10% to 90%)	ns	
Clock input timing reference level		Differential cross point		
V_{DIF} to clock		0.75	V	
V_{CM} to clock		1.10	V	
Output loading conditions		See figure below		

Note: Parameters are tested with $R_Q = 250\ \Omega$ and $V_{DDQ} = 1.5\text{ V}$.

Output Loading Conditions

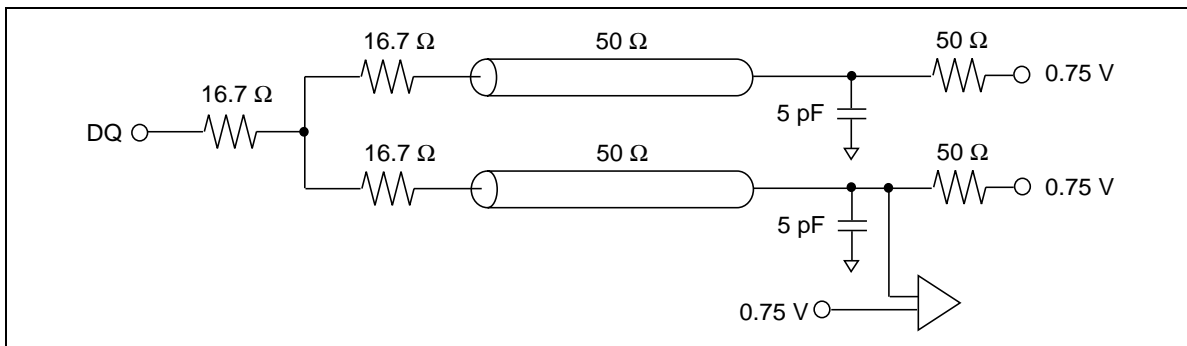

Boundary Scan Test Access Port Operations

Overview

In order to perform the interconnect testing of the modules that include this SRAM, the serial boundary scan test access port (TAP) is designed to operate in a manner consistent with IEEE Standard 1149.1 - 1990. But does not implement all of the functions required for 1149.1 compliance the HM64YLB series contains a TAP controller. Instruction register, boundary scans register, bypass register and ID register.

Test Access Port Pins

Symbol I/O	Name
TCK	Test clock
TMS	Test mode select
TDI	Test data in
TDO	Test data out

Note: This device does not have a TRST (TAP reset) pin. TRST is optional in IEEE 1149.1. To disable the TAP, TCK must be connected to V_{SS} . TDO should be left unconnected. To test boundary scan, the ZZ pin needs to be kept below $V_{REF} - 0.4$ V.

TAP DC Operating Characteristics (Ta = 0 to +85°C)

Parameter	Symbol	Min	Max	Notes
Boundary scan input high voltage	V_{IH}	1.4 V	3.6 V	
Boundary scan input low voltage	V_{IL}	-0.3 V	0.8 V	
Boundary scan input leakage current	I_{LI}	-10 μ A	+10 μ A	1
Boundary scan output low voltage	V_{OL}	—	0.2 V	2
Boundary scan output high voltage	V_{OH}	2.1 V	—	3
Boundary scan output leakage current	I_{LO}	-5 μ A	+5 μ A	4

- Notes:
- $0 \leq V_{IN} \leq 3.6$ V for all logic input pins
 - $I_{OL} = 2$ mA at $V_{DD} = 2.5$ V.
 - $I_{OH} = -2$ mA at $V_{DD} = 2.5$ V.
 - $0 \leq V_{OUT} \leq V_{DD}$, TDO in high-Z

TAP AC Operating Characteristics ($T_a = 0$ to $+85^\circ\text{C}$)

Parameter	Symbol	Min	Max	Unit	Note
Test clock cycle time	t_{THTH}	67	—	ns	
Test clock high pulse width	t_{THTL}	30	—	ns	
Test clock low pulse width	t_{TLTH}	30	—	ns	
Test mode select setup	t_{MVTH}	10	—	ns	
Test mode select hold	t_{THMX}	10	—	ns	
Capture setup	t_{CS}	10	—	ns	1
Capture hold	t_{CH}	10	—	ns	1
TDI valid to TCK high	t_{DVTH}	10	—	ns	
TCK high to TDI don't care	t_{THDX}	10	—	ns	
TCK low to TDO unknown	t_{TLQX}	0	—	ns	
TCK low to TDO valid	t_{TLOV}	—	20	ns	

Note: 1. $t_{\text{CS}} + t_{\text{CH}}$ defines the minimum pause in RAM I/O pad transitions to assure pad data capture.

TAP AC Test Conditions ($V_{\text{DD}} = 2.5 \text{ V}$)

Temperature	$0^\circ\text{C} \leq T_a \leq +85^\circ\text{C}$
Input timing measurement reference level	1.1 V
Input pulse levels	0 to 2.5 V
Input rise/fall time	1.5 ns typical (10% to 90%)
Output timing measurement reference level	1.25 V
Test load termination supply voltage (V_T)	1.25 V
Output load	See figure below

Boundary Scan AC Test Load

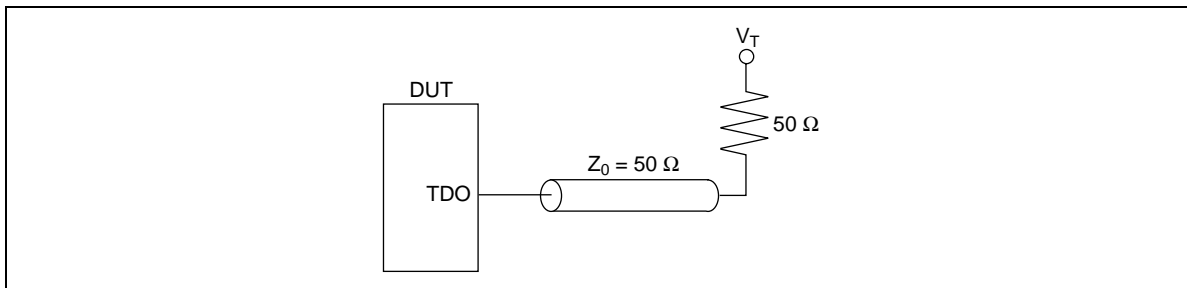

TAP Controller Timing Diagram

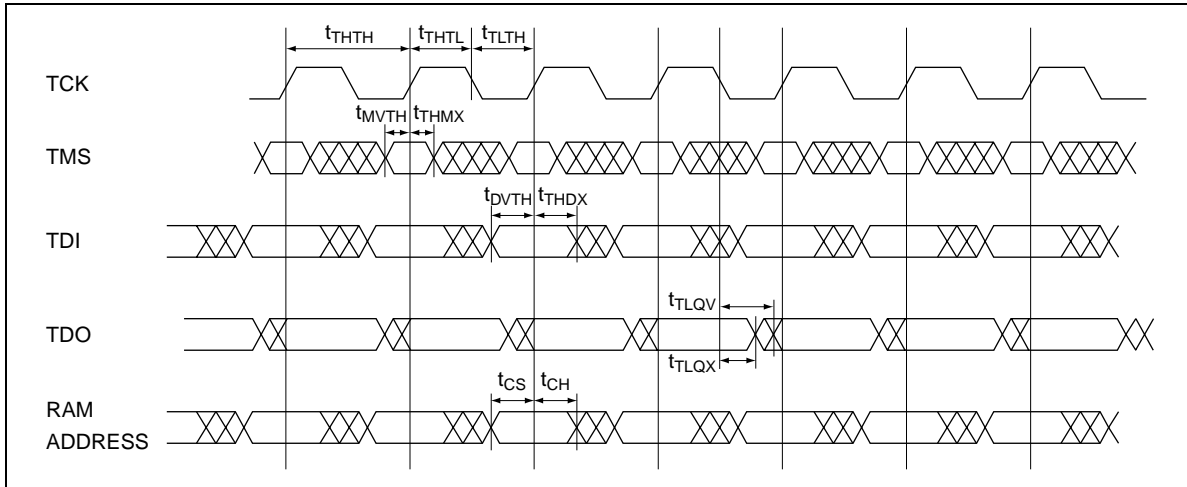

Test Access Port Registers

Register name	Length	Symbol	Note
Instruction register	3 bits	IR [2:0]	
Bypass register	1 bit	BP	
ID register	32 bits	ID [31:0]	
Boundary scan register	70 bits	BS [70:1]	

TAP Controller Instruction Set

IR2	IR1	IR0	Instruction	Operation
0	0	0	SAMPLE-Z	Tristate all data drivers and capture the pad value
0	0	1	IDCODE	
0	1	0	SAMPLE-Z	Tristate all data drivers and capture the pad value
0	1	1	BYPASS	
1	0	0	SAMPLE	
1	0	1	BYPASS	
1	1	0	PRIVATE	Do not use. They are reserved for vendor use only
1	1	1	BYPASS	

Note: This device does not perform EXTEST, INTEST or the preload portion of the PRELOAD command in IEEE 1149.1.

Boundary Scan Order (HM64YLB36514)

Bit #	Bump ID	Signal name	Bit #	Bump ID	Signal name
1	5R	M2	36	3B	SA12
2	4P	SA0	37	2B	SA15
3	4T	SA3	38	3A	SA13
4	6R	SA1	39	3C	SA11
5	5T	SA2	40	2C	SA16
6	7T	ZZ	41	2A	SA14
7	6P	DQa8	42	2D	DQc8
8	7P	DQa7	43	1D	DQc7
9	6N	DQa6	44	2E	DQc6
10	7N	DQa5	45	1E	DQc5
11	6M	DQa4	46	2F	DQc4
12	6L	DQa2	47	2G	DQc2
13	7L	DQa3	48	1G	DQc3
14	6K	DQa0	49	2H	DQc0
15	7K	DQa1	50	1H	DQc1
16	5L	$\overline{\text{SWEa}}$	51	3G	$\overline{\text{SWEc}}$
17	4L	$\overline{\text{K}}$	52	4D	ZQ
18	4K	K	53	4E	$\overline{\text{SS}}$
19	4F	$\overline{\text{G}}$	54	4G	NC
20	5G	$\overline{\text{SWEb}}$	55	4H	NC
21	7H	DQb1	56	4M	$\overline{\text{SWE}}$
22	6H	DQb0	57	3L	$\overline{\text{SWEd}}$
23	7G	DQb3	58	1K	DQd1
24	6G	DQb2	59	2K	DQd0
25	6F	DQb4	60	1L	DQd3
26	7E	DQb5	61	2L	DQd2
27	6E	DQb6	62	2M	DQd4
28	7D	DQb7	63	1N	DQd5
29	6D	DQb8	64	2N	DQd6
30	6A	SA7	65	1P	DQd7
31	6C	SA8	66	2P	DQd8
32	5C	SA4	67	3T	SA18
33	5A	SA6	68	2R	SA10
34	6B	SA9	69	4N	SA17
35	5B	SA5	70	3R	M1

HM64YLB36514 Series

- Notes:
1. Bit#1 is the first scan bit to exit the chip.
 2. The NC pads listed in this table are indeed no connects, but are represented in the boundary scan register by a "Place Holder". Place holder registers are internally connected to V_{SS} .
 3. In boundary scan mode, differential input K and \bar{K} are referenced to each other and must be at the opposite logic levels for the reliable operation.
 4. ZZ must remain V_{IL} during boundary scan.
 5. In boundary scan mode, ZQ must be driven to V_{DDQ} or V_{SS} supply rail to ensure consistent results.
 6. M1 and M2 must be driven to V_{DD} , V_{DDQ} or V_{SS} supply rail to ensure consistent results.

ID Register

Part	Revision number (31:28)	Device density and configuration (27:18)	Vendor definition (17:12)	Vendor JEDEC code (11:1)	Start bit (0)
HM64YLB36514	0000	0011100100	000000	00000000111	1

TAP Controller State Diagram

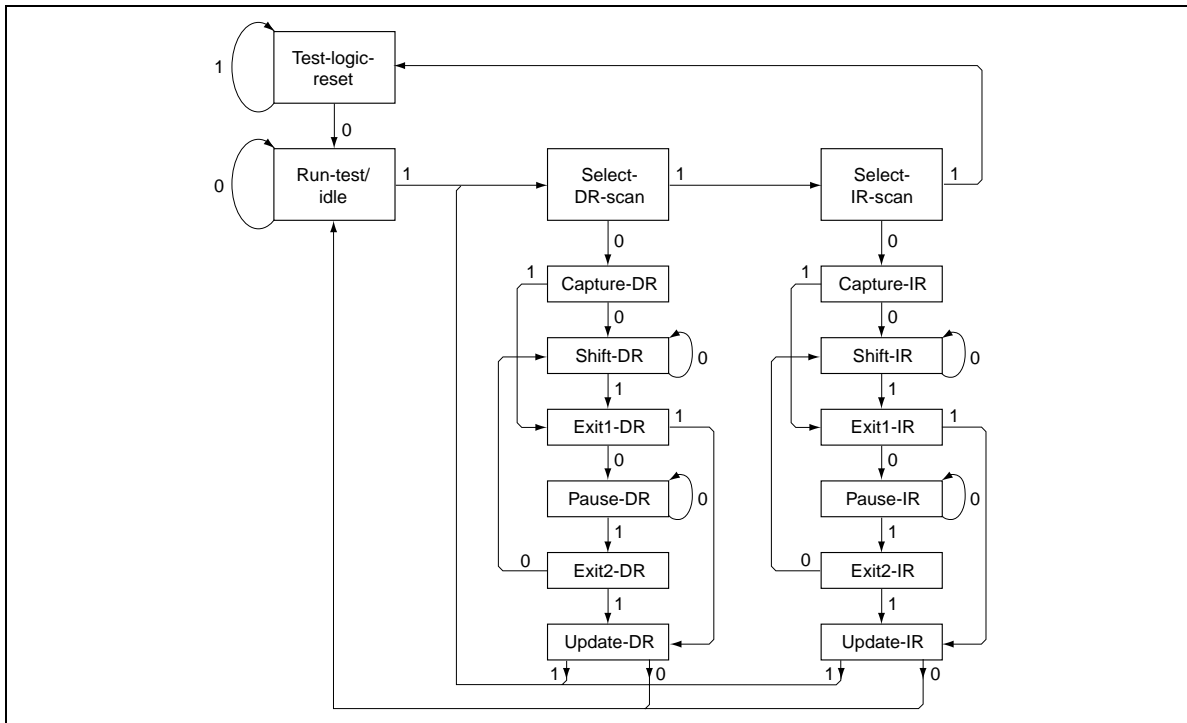

Note: The value adjacent to each state transition in this figure represents the signal present at TMS at the time of a rising edge at TCK.

No matter what the original state of the controller, it will enter Test-logic-reset when TMS is held high for at least five rising edges of TCK.

HM64YLB36514 Series

Package Dimensions

HM64YLB36514BP Series (BP-119E)

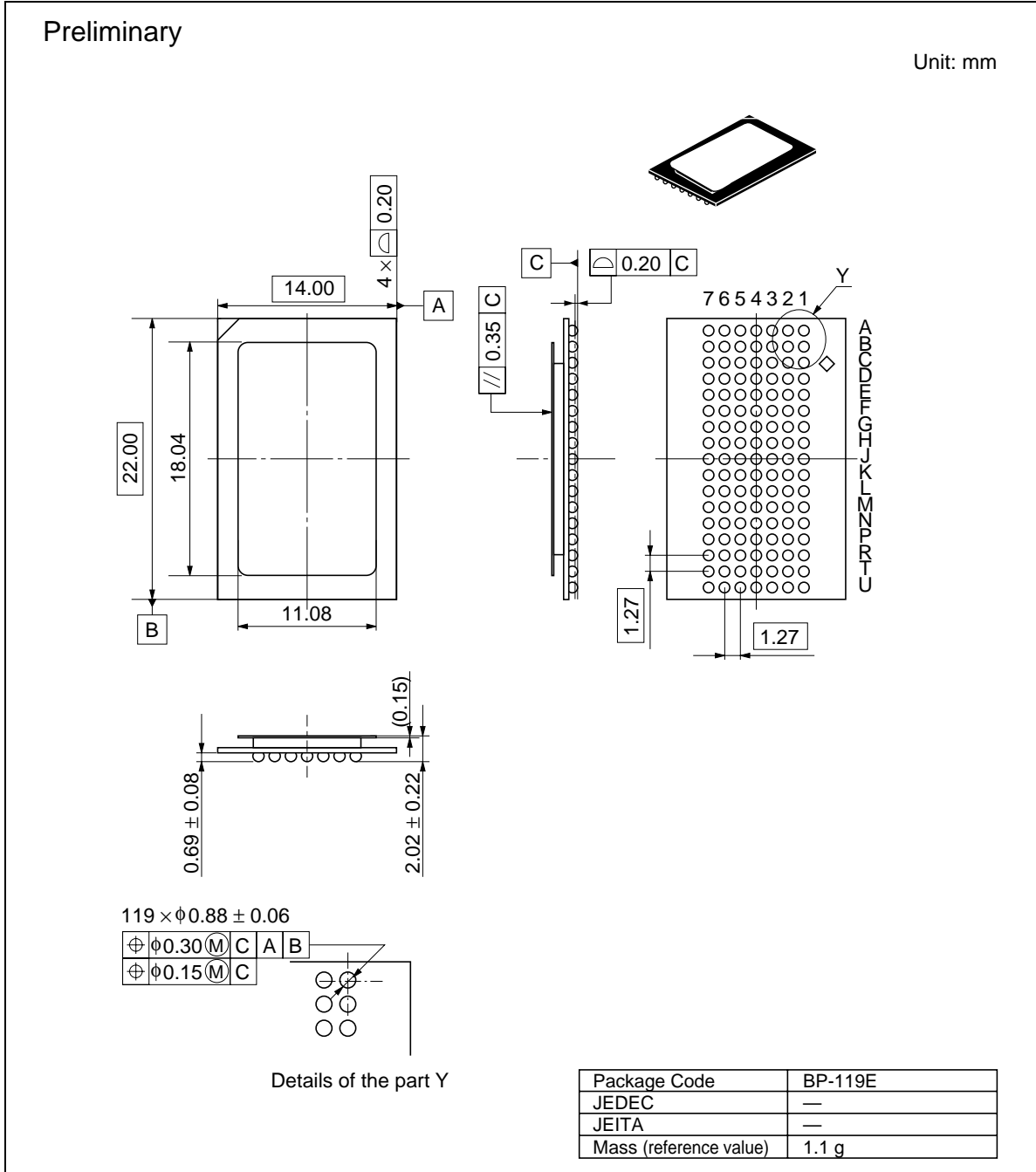

Renesas Technology Corp. Sales Strategic Planning Div. Nippon Bldg., 2-6-2, Ohte-machi, Chiyoda-ku, Tokyo 100-0004, Japan

Keep safety first in your circuit designs!

1. Renesas Technology Corporation puts the maximum effort into making semiconductor products better and more reliable, but there is always the possibility that trouble may occur with them. Trouble with semiconductors may lead to personal injury, fire or property damage.
Remember to give due consideration to safety when making your circuit designs, with appropriate measures such as (i) placement of substitutive, auxiliary circuits, (ii) use of nonflammable material or (iii) prevention against any malfunction or mishap.

Notes regarding these materials

1. These materials are intended as a reference to assist our customers in the selection of the Renesas Technology Corporation product best suited to the customer's application; they do not convey any license under any intellectual property rights, or any other rights, belonging to Renesas Technology Corporation or a third party.
 2. Renesas Technology Corporation assumes no responsibility for any damage, liability, or infringement of any third-party's rights, originating in the use of any product data, diagrams, charts, programs, algorithms, or circuit application examples contained in these materials.
 3. All information contained in these materials, including product data, diagrams, charts, programs and algorithms represents information on products at the time of publication of these materials, and are subject to change by Renesas Technology Corporation without notice due to product improvements or other reasons. It is therefore recommended that customers contact Renesas Technology Corporation or an authorized Renesas Technology Corporation product distributor for the latest product information before purchasing a product listed herein.
The information described here may contain technical inaccuracies or typographical errors.
Renesas Technology Corporation assumes no responsibility for any damage, liability, or other loss rising from these inaccuracies or errors.
Please also pay attention to information published by Renesas Technology Corporation by various means, including the Renesas Technology Corporation Semiconductor home page (<http://www.renesas.com>).
 4. When using any or all of the information contained in these materials, including product data, diagrams, charts, programs, and algorithms, please be sure to evaluate all information as a total system before making a final decision on the applicability of the information and products. Renesas Technology Corporation assumes no responsibility for any damage, liability or other loss resulting from the information contained herein.
 5. Renesas Technology Corporation semiconductors are not designed or manufactured for use in a device or system that is used under circumstances in which human life is potentially at stake. Please contact Renesas Technology Corporation or an authorized Renesas Technology Corporation product distributor when considering the use of a product contained herein for any specific purposes, such as apparatus or systems for transportation, vehicular, medical, aerospace, nuclear, or undersea repeater use.
 6. The prior written approval of Renesas Technology Corporation is necessary to reprint or reproduce in whole or in part these materials.
 7. If these products or technologies are subject to the Japanese export control restrictions, they must be exported under a license from the Japanese government and cannot be imported into a country other than the approved destination.
Any diversion or reexport contrary to the export control laws and regulations of Japan and/or the country of destination is prohibited.
 8. Please contact Renesas Technology Corporation for further details on these materials or the products contained therein.
-



<http://www.renesas.com>

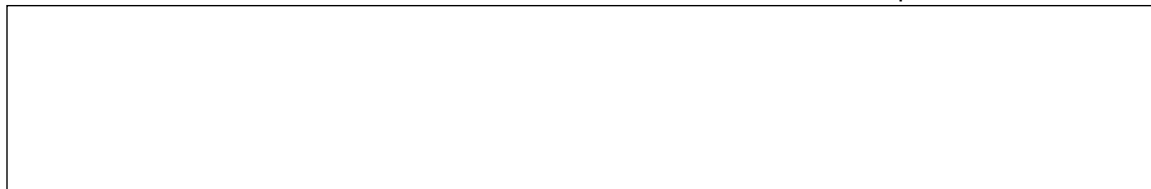

Copyright © 2003. Renesas Technology Corporation, All rights reserved. Printed in Japan.
Colophon 0.0