

N-Channel Enhancement Mode MOSFET

Feature

- 60V/0.2A, $R_{DS(ON)} = 7.5\Omega$ (MAX) @ $V_{GS} = 10V$, $I_D = 0.4A$
 $R_{DS(ON)} = 7.5\Omega$ (MAX) @ $V_{GS} = 5V$, $I_D = 0.05A$
- Super High dense cell design for extremely low $R_{DS(ON)}$.
- Reliable and Rugged.
- SOT-23 for Surface Mount Package.

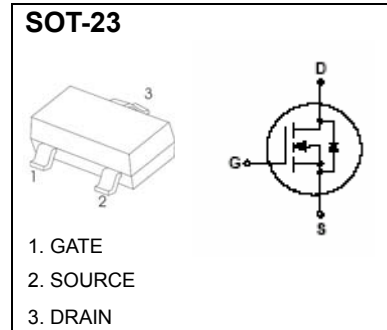

Applications

- Power Management in Desktop Computer or DC/DC Converters .

Absolute Maximum Ratings

$T_A=25^\circ C$ Unless Otherwise noted

Parameter	Symbol	Limit	Units
Drain-Source Voltage	V_{DS}	60	V
Gate-Source Voltage	V_{GS}	± 20	V
Drain Current-Continuous	I_D	0.2	A
Power Dissipation	P_D	0.225	W
Thermal Resistance from Junction to Ambient	$R_{\theta JA}$	556	$^\circ C/W$
Junction Temperature	T_J	150	$^\circ C$
Storage Temperature	T_{stg}	-50~+150	

Electrical Characteristics

$T_A=25^\circ C$ Unless Otherwise noted

Parameter	Symbol	Test Conditions	Min	Typ.	Max	Units
Off Characteristics						
Drain to Source Breakdown Voltage	BVDSS	$V_{GS}=0V, I_D=250\mu A$	60	-	-	V
Zero-Gate Voltage Drain Current	I_{DSS}	$V_{DS}=60V, V_{GS}=0V$	-	-	1	μA
Gate Body Leakage Current, Forward	I_{GSSF}	$V_{GS}=20V, V_{DS}=0V$	-	-	100	nA
Gate Body Leakage Current, Reverse	I_{GSSR}	$V_{GS}=-20V, V_{DS}=0V$	-	-	-100	nA
On Characteristics						
Gate Threshold Voltage	$V_{GS(th)}$	$V_{GS}=V_{DS}, I_D=250\mu A$	1	-		V
Static Drain-source On-Resistance *	$R_{DS(ON)}$	$V_{GS}=10V, I_D=0.4A$	-		7.5	Ω
		$V_{GS}=5V, I_D=0.05A$	-		7.5	Ω
Drain-Source Diode Characteristics and Maximum Ratings						
Drain-Source Diode Forward Voltage	VSD	$V_{GS}=0V, I_S=0.2A$			2.5	V

Notes :

*Pulse Test : Pulse Width $\leq 300\mu s$, Duty Cycle $\leq 2\%$.

N-Channel Enhancement Mode MOSFET

Typical Characteristics

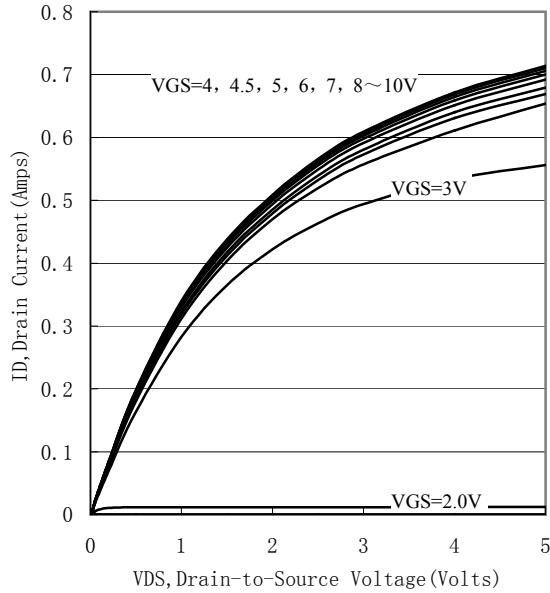

Figure 1. Output Characteristics

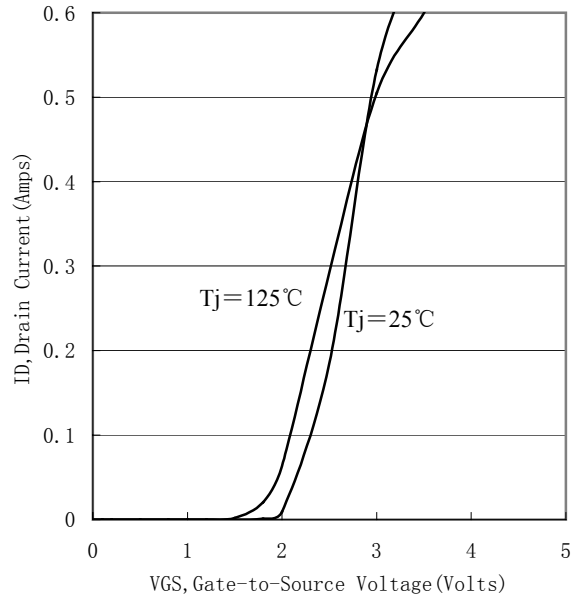

Figure 2. Transfer Characteristics

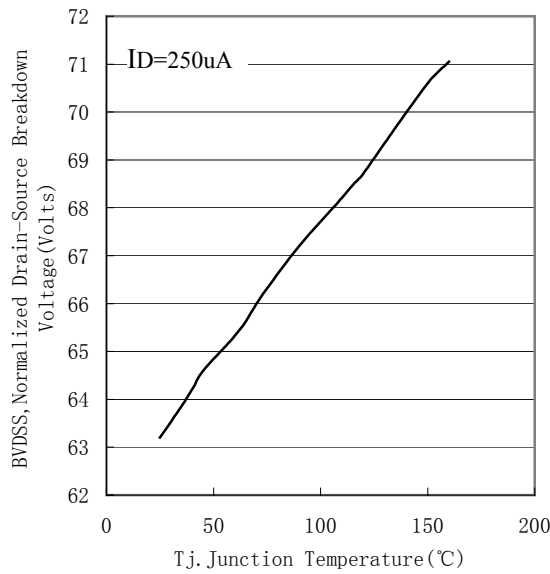

Figure 3. Breakdown Voltage Variation with Temperature

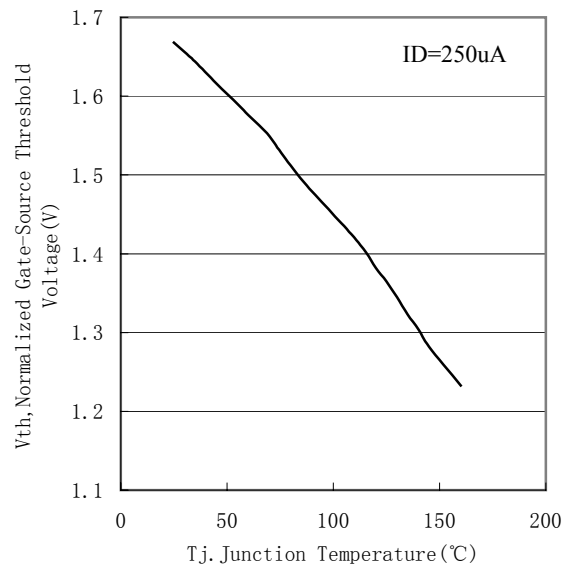

Figure 4. Gate Threshold Variation with Temperature

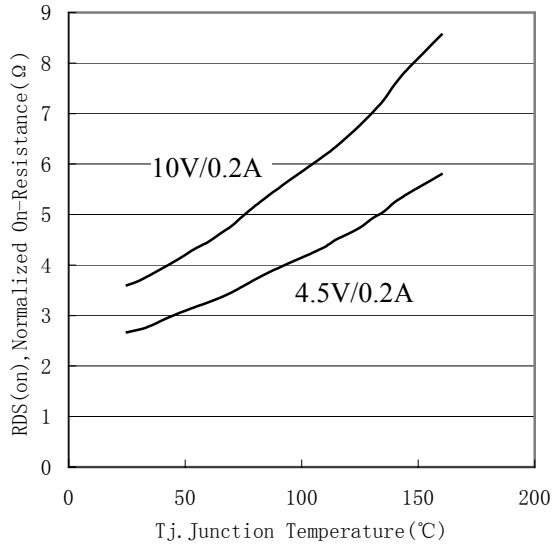

Figure 5. On-Resistance Variation with Temperature

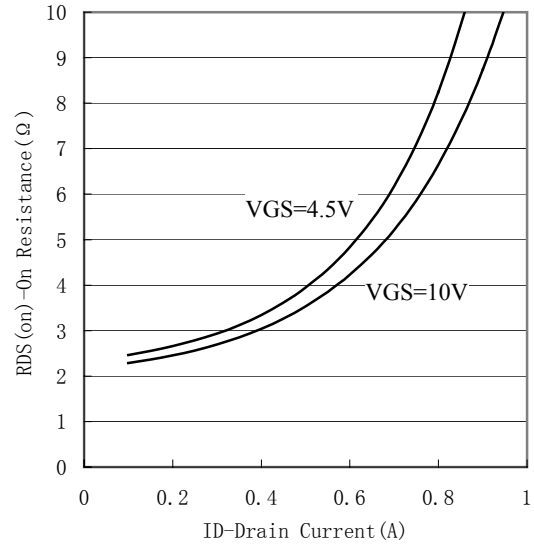

Figure 6. On-Resistance vs. Drain Current

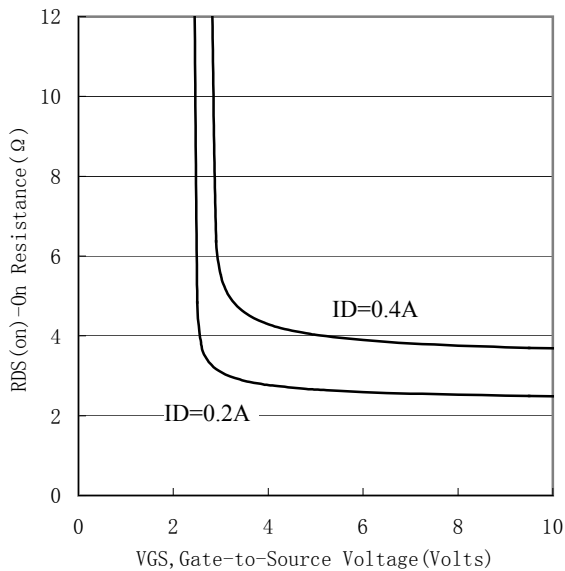

Figure 7. On-Resistance vs. Gate-to-Source Voltage

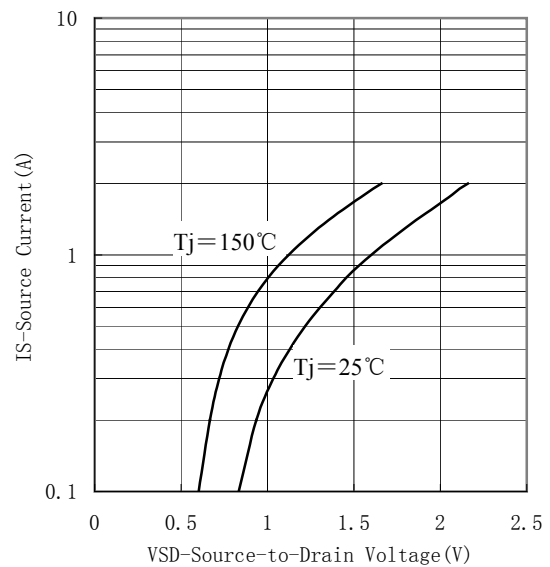

Figure 8. Source-Drain Diode Forward Voltage