

Features

- Low power consumption
- Low voltage drop
- Low temperature coefficient
- Ultra low quiescent current: 2 μ A(typ.)
- High input voltage (up to 15V)
- Maximum output current: 10mA
- Output voltage accuracy: tolerance $\pm 2\%$
- TO92, SOT89 and SOT23 package

Applications

- Battery-powered equipment
- Communication equipment
- Audio/Video equipment

General Description

The HT 73XX series is a set of three-terminal low power high voltage regulators implemented in CMOS technology. They allow input voltages as high as 15V. The series features extremely low quiescent current which is typically 2 μ A. They are available with several fixed output voltages ranging from 2.1V to 5.0V. CMOS technology ensures low voltage drop and low quiescent current. Although designed primarily as fixed voltage regulators, these devices can be used with external components to obtain variable voltages and currents.

Selection Table

Part No.	Output Voltage	Package	Marking
HO 7325xx	2.5V	TO92 SOT89 SOT23	"95ZZ/C"(for TO92) "95ZZ/C"(for SOT89) "5ZZ"(for SOT23)
HO 7327xx	2.7V		
HO 7330xx	3.0V		
HO 7333xx	3.3V		
HO 7336xx	3.6V		
HO 7340xx	4.0V		
HO 7344xx	4.4V		
HO 7350xx	5.0V		

Note:"XX" stands for output voltages.

SOT89 & SOT23 packages will add a "#" mark at the end of the marking.

Order Information

HM73①②③④

Designator	Symbol	Description
① ②	Integer	Output Voltage(2.5~5.0V)
③	T	Package:TO-92
	P	Package:SOT89
	M	Package:SOT23
④	R	RoHS / Pb Free
	G	Halogen Free

Block Diagram

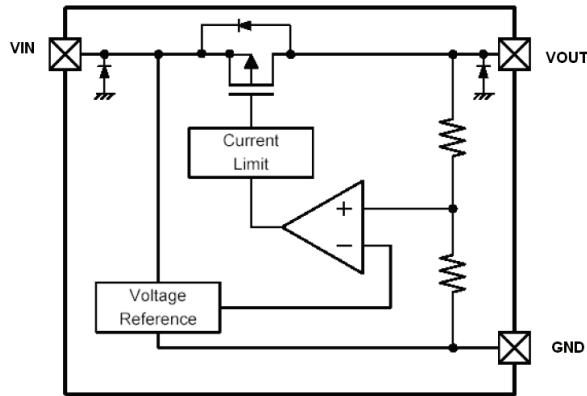

*Diodes inside the circuit are an ESD protection diode and a parasitic diode.

Pin Assignment

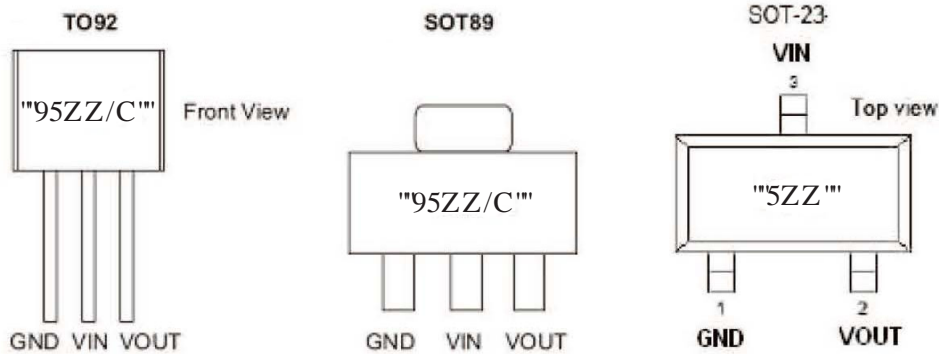

Absolute Maximum Ratings

Supply Voltage-0.3V to 18V Storage Temperature-50°C to 125°C
 Operating Temperature-40°C to 85°C

Note: These are stress ratings only. Stresses exceeding the range specified under “Absolute Maximum Ratings” may cause substantial damage to the device. Functional operation of this device at other conditions beyond those listed in the specification is not implied and prolonged exposure to extreme conditions may affect device reliability.

Thermal Information

Symbol	Parameter	Package	Max.	Unit
θ_{JA}	Thermal Resistance (Junction to Ambient) (Assume no ambient airflow, no heat sink)	SOT23	500	°C/W
		SOT89	200	°C/W
		TO92	200	°C/W
P_D	Power Dissipation	SOT23	0.20	W
		SOT89	0.50	W
		TO92	0.50	W

Note: P_D is measured at $T_a = 25^\circ\text{C}$

Electrical Characteristics

HA 7325xx, +2.5V Output Type

Symbol	Parameter	Test Conditions		Min.	Typ.	Max.	Unit
		V _{IN}	Conditions				
V _{OUT}	Output Voltage	3.5V	I _{OUT} =40mA	2.45	2.500	2.55	V
I _{OUT}	Output Current	3.5V	-	180	250	-	mA
ΔV _{OUT}	Load Regulation	3.5V	1mA ≤ I _{OUT} ≤ 60mA	-	45	90	mV
V _{DIF}	Voltage Drop(Note)	-	I _{OUT} =40mA, ΔV _{OUT} =2%	-	100	-	mV
ISS	Current Consumption	3.5V	No load	-	2.5	3	μA
$\frac{\Delta V_{OUT}}{\Delta V_{IN} \times V_{OUT}}$	Line Regulation	-	3.5V ≤ V _{IN} ≤ 12V I _{OUT} =40mA	-	0.2	-	%/V
V _{IN}	Input Voltage	-	-	-	-	15	V
$\frac{\Delta V_{OUT}}{\Delta Ta}$	Temperature Coefficient	3.5V	I _{OUT} =40mA -40°C < Ta < 85°C	-	±0.5	-	mV/°C

Note: Dropout voltage is defined as the input voltage minus the output voltage that produces a 2% change in the output voltage from the value at V_{IN} = V_{OUT}+1V with a fixed load.

HA 7327xx, +2.7V Output Type

Symbol	Parameter	Test Conditions		Min.	Typ.	Max.	Unit
		V _{IN}	Conditions				
V _{OUT}	Output Voltage	3.7V	I _{OUT} =10mA	2.646	2.700	2.754	V
I _{OUT}	Output Current	3.7V	-	200	250	-	mA
ΔV _{OUT}	Load Regulation	3.7V	1mA ≤ I _{OUT} ≤ 60mA	-	45	90	mV
V _{DIF}	Voltage Drop(Note)	-	I _{OUT} =40mA, ΔV _{OUT} =2%	-	100	-	mV
ISS	Current Consumption	3.7V	No load	-	2.5	3	μA
$\frac{\Delta V_{OUT}}{\Delta V_{IN} \times V_{OUT}}$	Line Regulation	-	3.7V ≤ V _{IN} ≤ 12V I _{OUT} =40mA	-	0.2	-	%/V
V _{IN}	Input Voltage	-	-	-	-	15	V
$\frac{\Delta V_{OUT}}{\Delta Ta}$	Temperature Coefficient	3.7V	I _{OUT} =10mA -40°C < Ta < 85°C	-	±0.5	-	mV/°C

Note: Dropout voltage is defined as the input voltage minus the output voltage that produces a 2% change in the output voltage from the value at V_{IN} = V_{OUT}+1V with a fixed load.

HA 7330xx, +3.0V Output Type

Symbol	Parameter	Test Conditions		Min.	Typ.	Max.	Unit
		V _{IN}	Conditions				
V _{OUT}	Output Voltage	4V	I _{OUT} =40mA	2.94	3.00	2.06	V
I _{OUT}	Output Current	4V	-	250	-	-	mA
ΔV _{OUT}	Load Regulation	4V	1mA ≤ I _{OUT} ≤ 80mA	-	45	90	mV
V _{DIF}	Voltage Drop(Note)	-	I _{OUT} =40mA, ΔV _{OUT} =2%	-	100	-	mV
ISS	Current Consumption	4V	No load	-	2.5	3	μA
$\frac{\Delta V_{OUT}}{\Delta V_{IN} \times V_{OUT}}$	Line Regulation	-	4V ≤ V _{IN} ≤ 12V I _{OUT} =40mA	-	0.2	-	%/V
V _{IN}	Input Voltage	-	-	-	-	15	V
$\frac{\Delta V_{OUT}}{\Delta Ta}$	Temperature Coefficient	4V	I _{OUT} =40mA -40°C < Ta < 85°C	-	±0.5	-	mV/°C

Note: Dropout voltage is defined as the input voltage minus the output voltage that produces a 2% change in the output voltage from the value at V_{IN} = V_{OUT}+1V with a fixed load.

HA 7333xx, +3.3V Output Type

Symbol	Parameter	Test Conditions		Min.	Typ.	Max.	Unit
		V _{IN}	Conditions				
V _{OUT}	Output Voltage	4.3V	I _{OUT} =40mA	3.234	3.300	3.366	V
I _{OUT}	Output Current	4.3V	-	250	-	-	mA
ΔV _{OUT}	Load Regulation	4.3V	1mA ≤ I _{OUT} ≤ 80mA	-	45	90	mV
V _{DIF}	Voltage Drop(Note)	-	I _{OUT} =40mA, ΔV _{OUT} =2%	-	100	-	mV
ISS	Current Consumption	4.3V	No load	-	2.5	3	μA
$\frac{\Delta V_{OUT}}{\Delta V_{IN} \times V_{OUT}}$	Line Regulation	-	4.3V ≤ V _{IN} ≤ 12V I _{OUT} =40mA	-	0.2	-	%/V
V _{IN}	Input Voltage	-	-	-	-	15	V
$\frac{\Delta V_{OUT}}{\Delta Ta}$	Temperature Coefficient	4.3V	I _{OUT} =40mA -40°C < Ta < 85°C	-	±0.5	-	mV/°C

Note: Dropout voltage is defined as the input voltage minus the output voltage that produces a 2% change in the output voltage from the value at V_{IN} = V_{OUT}+1V with a fixed load.

HA 7336xx, +3.6V Output Type

Symbol	Parameter	Test Conditions		Min.	Typ.	Max.	Unit
		V _{IN}	Conditions				
V _{OUT}	Output Voltage	4.6V	I _{OUT} =40mA	3.528	3.600	3.672	V
I _{OUT}	Output Current	4.6V	-	250	-	-	mA
ΔV _{OUT}	Load Regulation	4.6V	1mA ≤ I _{OUT} ≤ 80mA	-	45	90	mV
V _{DIF}	Voltage Drop(Note)	-	I _{OUT} =40mA, ΔV _{OUT} =2%	-	80	-	mV
ISS	Current Consumption	4.6V	No load	-	2.5	3.0	μA
$\frac{\Delta V_{OUT}}{\Delta V_{IN} \times V_{OUT}}$	Line Regulation	-	4.6V ≤ V _{IN} ≤ 12V I _{OUT} =40mA	-	0.2	-	%/V
V _{IN}	Input Voltage	-	-	-	-	15	V
$\frac{\Delta V_{OUT}}{\Delta T_a}$	Temperature Coefficient	4.6V	I _{OUT} =40mA -40°C < T _a < 85°C	-	±0.5	-	mV/°C

Note: Dropout voltage is defined as the input voltage minus the output voltage that produces a 2% change in the output voltage from the value at V_{IN} = V_{OUT}+1V with a fixed load.

HA 7340xx, +4.0V Output Type

Symbol	Parameter	Test Conditions		Min.	Typ.	Max.	Unit
		V _{IN}	Conditions				
V _{OUT}	Output Voltage	5.0V	I _{OUT} =40mA	3.920	4.000	4.080	V
I _{OUT}	Output Current	5.0V	-	250	-	-	mA
ΔV _{OUT}	Load Regulation	5.0V	1mA ≤ I _{OUT} ≤ 80mA	-	45	90	mV
V _{DIF}	Voltage Drop(Note)	-	I _{OUT} =40mA, ΔV _{OUT} =2%	-	80	-	mV
ISS	Current Consumption	5.0V	No load	-	2.5	3.0	μA
$\frac{\Delta V_{OUT}}{\Delta V_{IN} \times V_{OUT}}$	Line Regulation	-	5V ≤ V _{IN} ≤ 12V I _{OUT} =40mA	-	0.2	-	%/V
V _{IN}	Input Voltage	-	-	-	-	15	V
$\frac{\Delta V_{OUT}}{\Delta T_a}$	Temperature Coefficient	5.0V	I _{OUT} =40mA -40°C < T _a < 85°C	-	±0.5	-	mV/°C

Note: Dropout voltage is defined as the input voltage minus the output voltage that produces a 2% change in the output voltage from the value at V_{IN} = V_{OUT}+1V with a fixed load.

HA 7344xx, +4.4V Output Type

Symbol	Parameter	Test Conditions		Min.	Typ.	Max.	Unit
		V _{IN}	Conditions				
V _{OUT}	Output Voltage	5.4V	I _{OUT} =40mA	4.312	4.400	4.488	V
I _{OUT}	Output Current	5.4V	-	250	-	-	mA
ΔV _{OUT}	Load Regulation	5.4V	1mA ≤ I _{OUT} ≤ 80mA	-	45	90	mV
V _{DIF}	Voltage Drop(Note)	-	I _{OUT} =40mA, ΔV _{OUT} =2%	-	80	-	mV
ISS	Current Consumption	5.4V	No load	-	2.5	3.0	μA
$\frac{\Delta V_{OUT}}{\Delta V_{IN} \times V_{OUT}}$	Line Regulation	-	5.4V ≤ V _{IN} ≤ 12V I _{OUT} =40mA	-	0.2	-	%/V
V _{IN}	Input Voltage	-	-	-	-	15	V
$\frac{\Delta V_{OUT}}{\Delta T_a}$	Temperature Coefficient	5.4V	I _{OUT} =40mA -40°C < T _a < 85°C	-	±0.5	-	mV/°C

Note: Dropout voltage is defined as the input voltage minus the output voltage that produces a 2% change in the output voltage from the value at V_{IN} = V_{OUT}+1V with a fixed load.

HA 7350xx, +5.0V Output Type

Symbol	Parameter	Test Conditions		Min.	Typ.	Max.	Unit
		V _{IN}	Conditions				
V _{OUT}	Output Voltage	6V	I _{OUT} =40mA	4.9	5.00	5.1	V
I _{OUT}	Output Current	6V	-	250	-	-	mA
ΔV _{OUT}	Load Regulation	6V	1mA ≤ I _{OUT} ≤ 80mA	-	45	90	mV
V _{DIF}	Voltage Drop(Note)	-	I _{OUT} =40mA, ΔV _{OUT} =2%	-	80	-	mV
ISS	Current Consumption	6V	No load	-	2.5	3.0	μA
$\frac{\Delta V_{OUT}}{\Delta V_{IN} \times V_{OUT}}$	Line Regulation	-	6V ≤ V _{IN} ≤ 12V I _{OUT} =40mA	-	0.2	-	%/V
V _{IN}	Input Voltage	-	-	-	-	15	V
$\frac{\Delta V_{OUT}}{\Delta T_a}$	Temperature Coefficient	6V	I _{OUT} =40mA -40°C < T _a < 85°C	-	±0.5	-	mV/°C

Note: Dropout voltage is defined as the input voltage minus the output voltage that produces a 2% change in the output voltage from the value at V_{IN} = V_{OUT}+1V with a fixed load.

Typical Performance Characteristics

(1) Output Voltage vs Input voltage

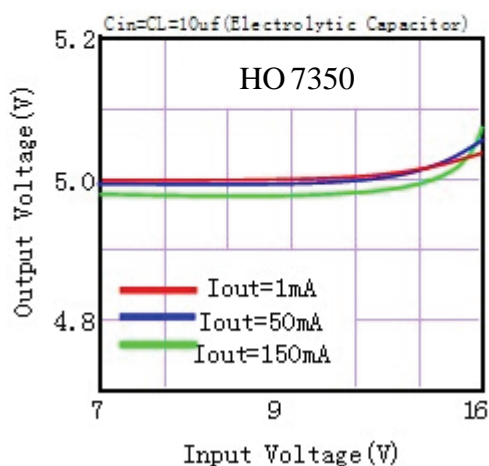
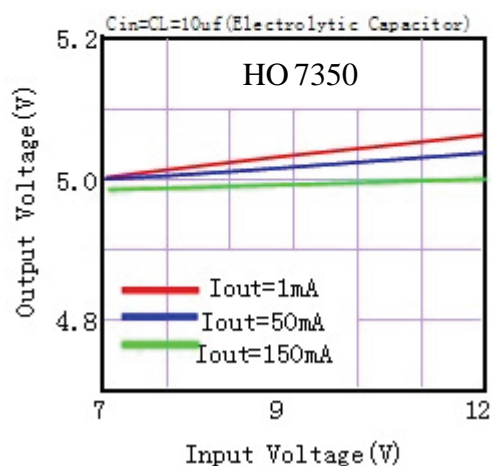
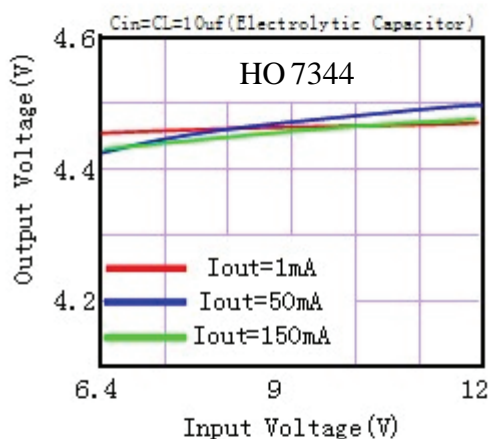
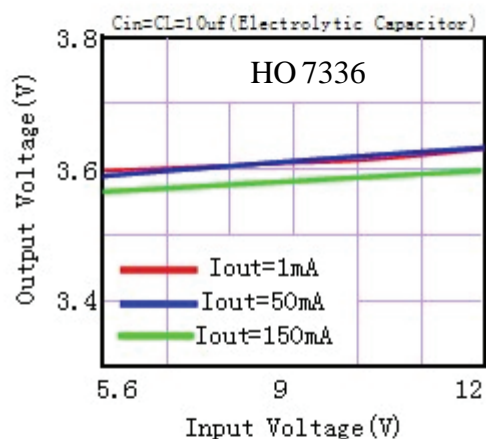
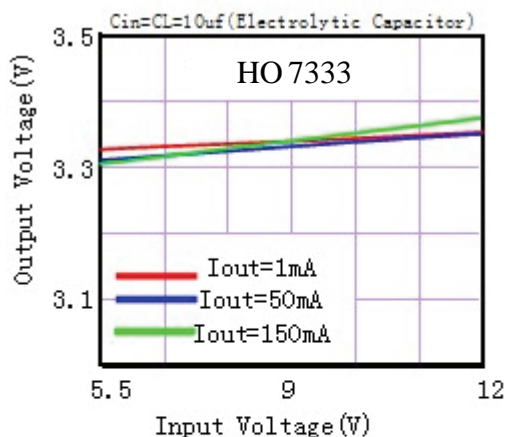
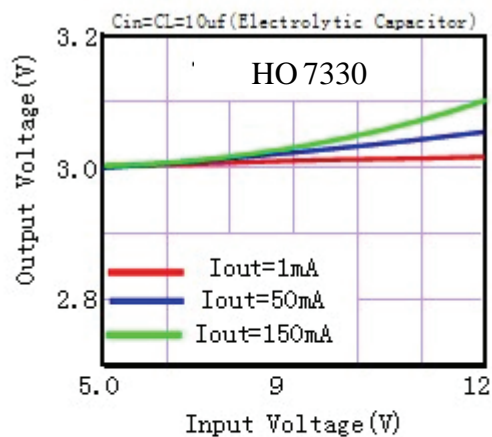

(2) Output Voltage vs. Output Current

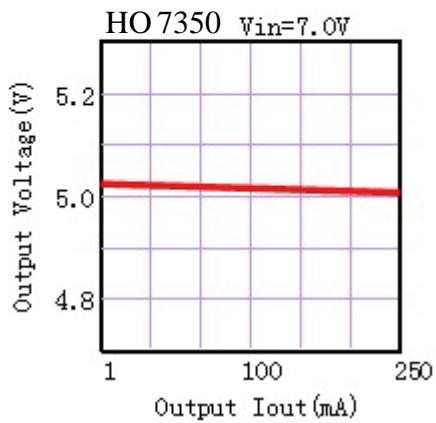
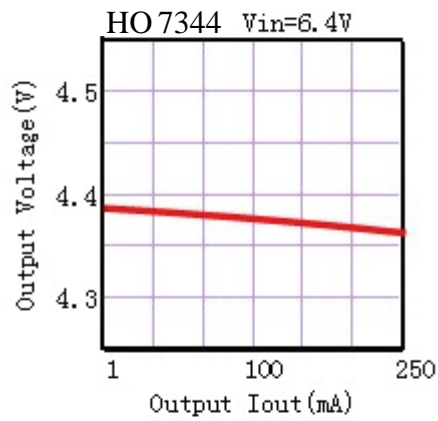
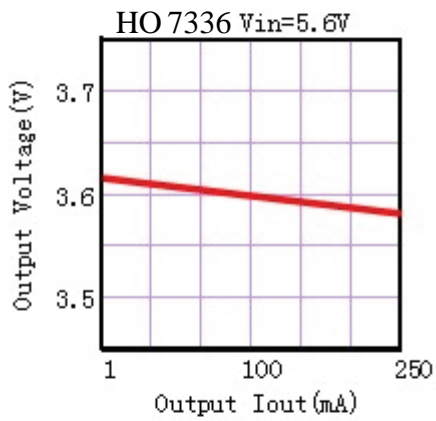
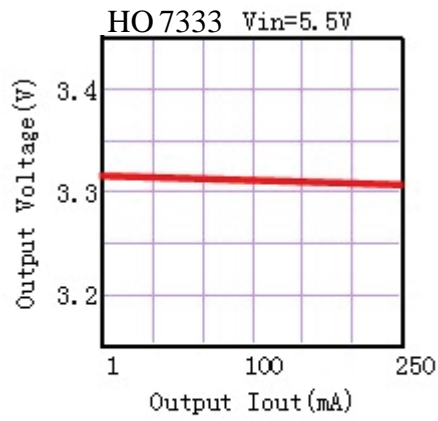
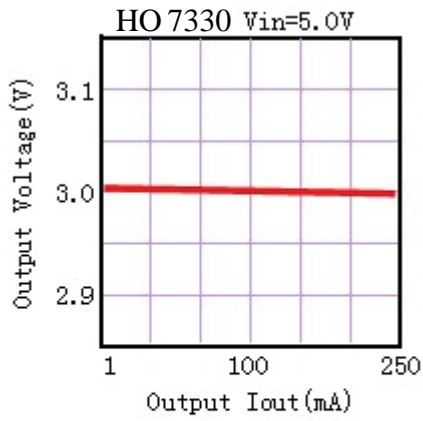

(3) Input Transient Response

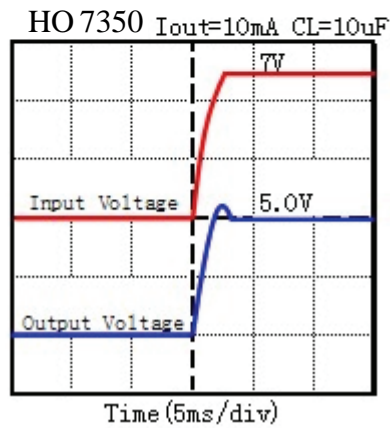
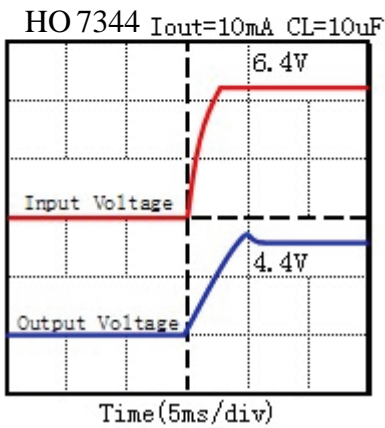
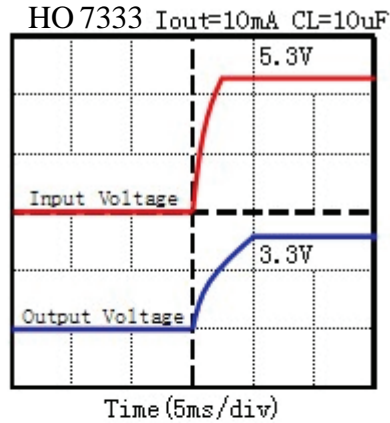
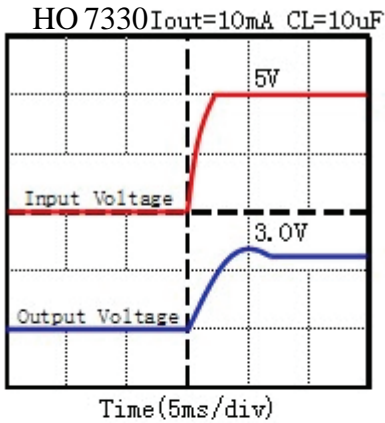

(4) Output Voltage vs.Ambient Temperature

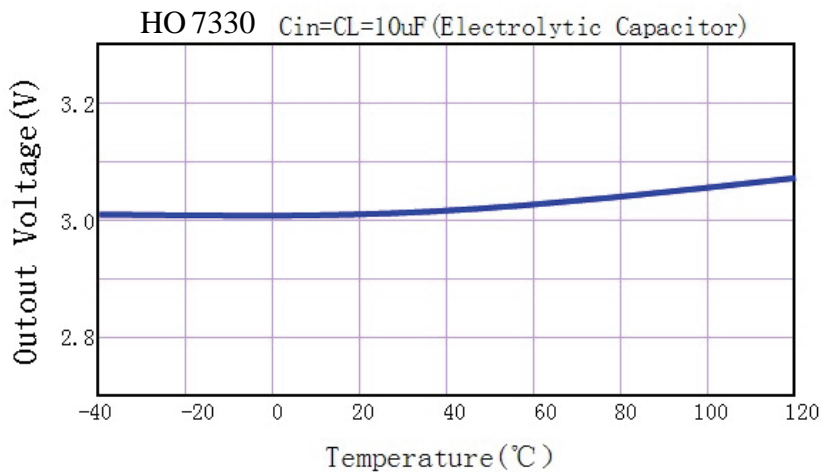

(5) MAX Output Current Vs. Input Voltage

HO 7330

Input Voltage	Max Output Current
5V	0mA
9V	200mA
12V	150mA
15V	100mA

HO 7333

Input Voltage	Max Output Current
5.3V	0mA
9V	200mA
12V	150mA
15V	100mA

HO 7350

Input Voltage	Max Output Current
7V	0mA
9V	200mA
12V	150mA
15V	100mA

Application Circuits

Basic Circuits

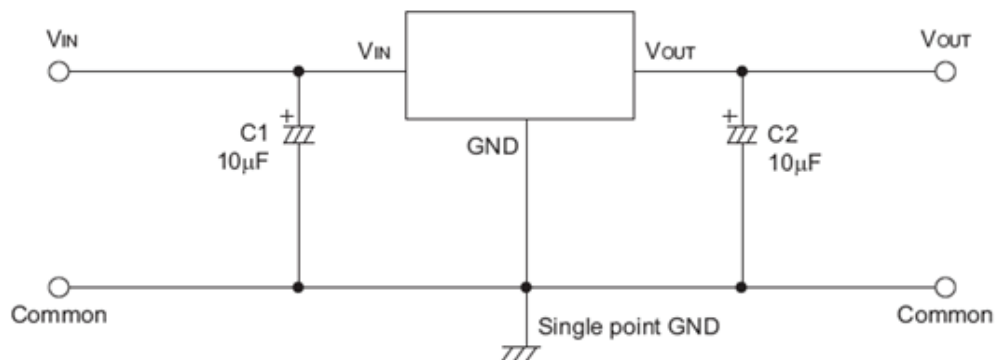

Package Information
3-pin TO92 Outline Dimensions

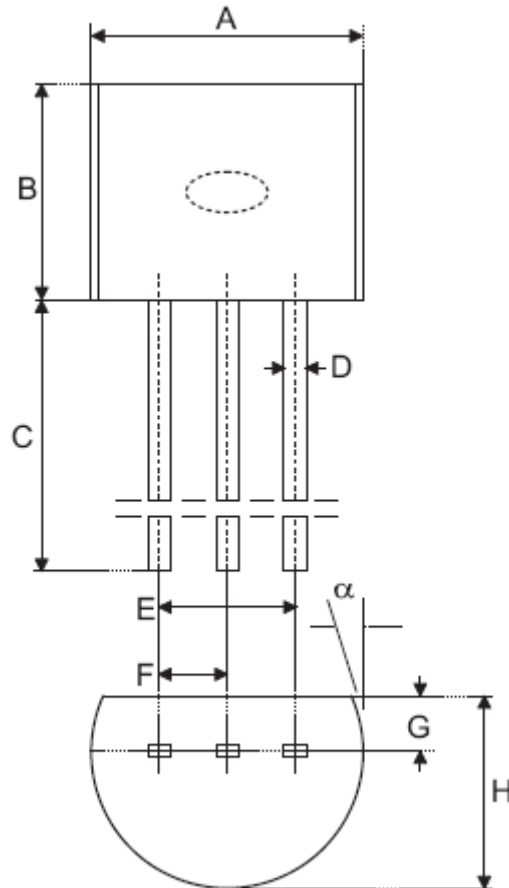

Symbol	Dimensions in mil		
	Min.	Nom.	Max.
A	170	—	200
B	170	—	200
C	500	—	—
D	11	—	20
E	90	—	110
F	45	—	55
G	45	—	65
H	130	—	160
I	8	—	18
α	4°	—	6°

3-pin SOT89 Outline Dimensions

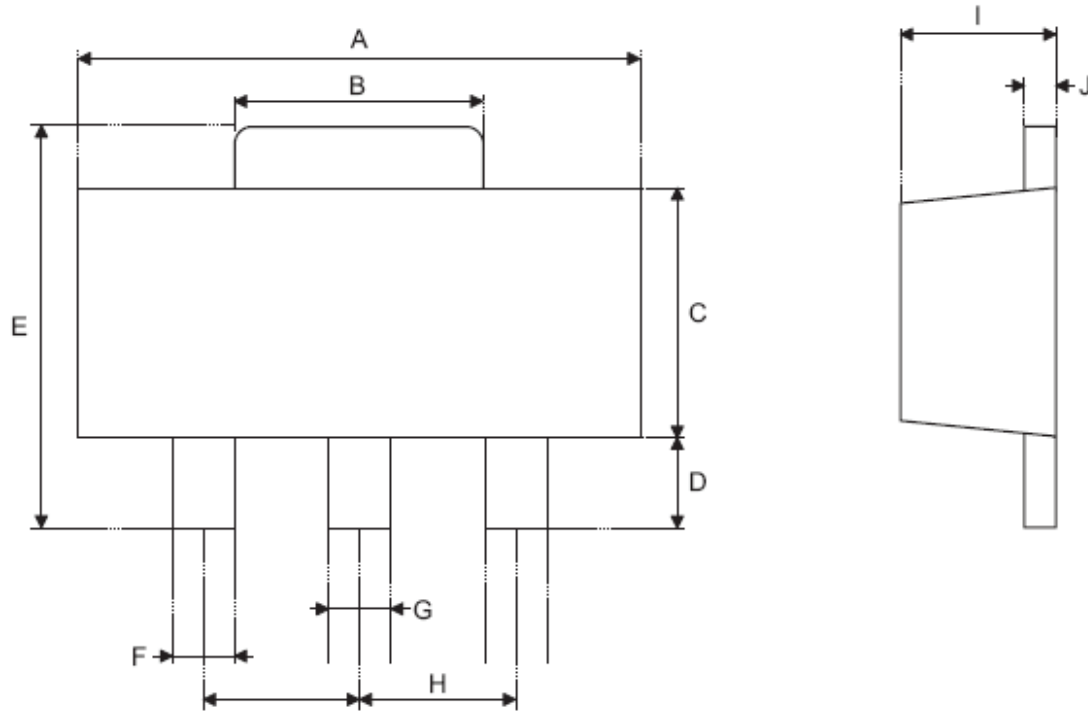

Symbol	Dimensions in mil		
	Min.	Nom.	Max.
A	173	—	181
B	59	—	72
C	90	—	102
D	35	—	47
E	155	—	167
F	14	—	19
G	17	—	22
H	—	59	—
I	55	—	63
J	14	—	17

3-pin SOT23 Outline Dimensions

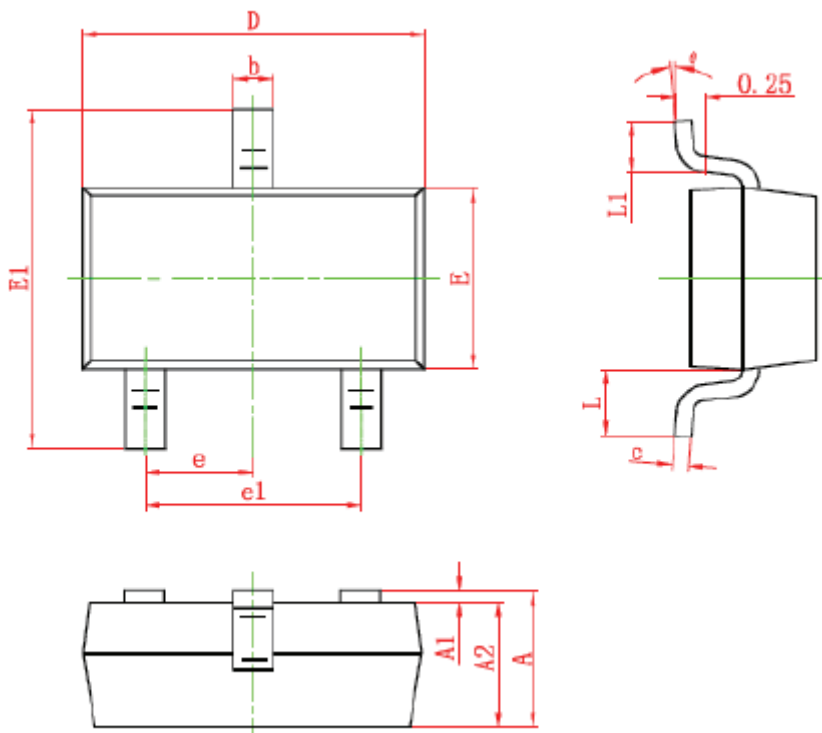

Symbol	Dimensions In Millimeters		Dimensions In Inches	
	Min	Max	Min	Max
A	0.900	1.150	0.035	0.045
A1	0.000	0.100	0.000	0.004
A2	0.900	1.050	0.035	0.041
b	0.300	0.500	0.012	0.020
c	0.080	0.150	0.003	0.006
D	2.800	3.000	0.110	0.118
E	1.200	1.400	0.047	0.055
E1	2.250	2.550	0.089	0.100
e	0.950 TYP		0.037 TYP	
e1	1.800	2.000	0.071	0.079
L	0.550 REF		0.022 REF	
L1	0.300	0.500	0.012	0.020
θ	0°	8°	0°	6°

Product Tape and Reel Specifications
3-pin TO92 Reel Dimensions (Unit: mm)

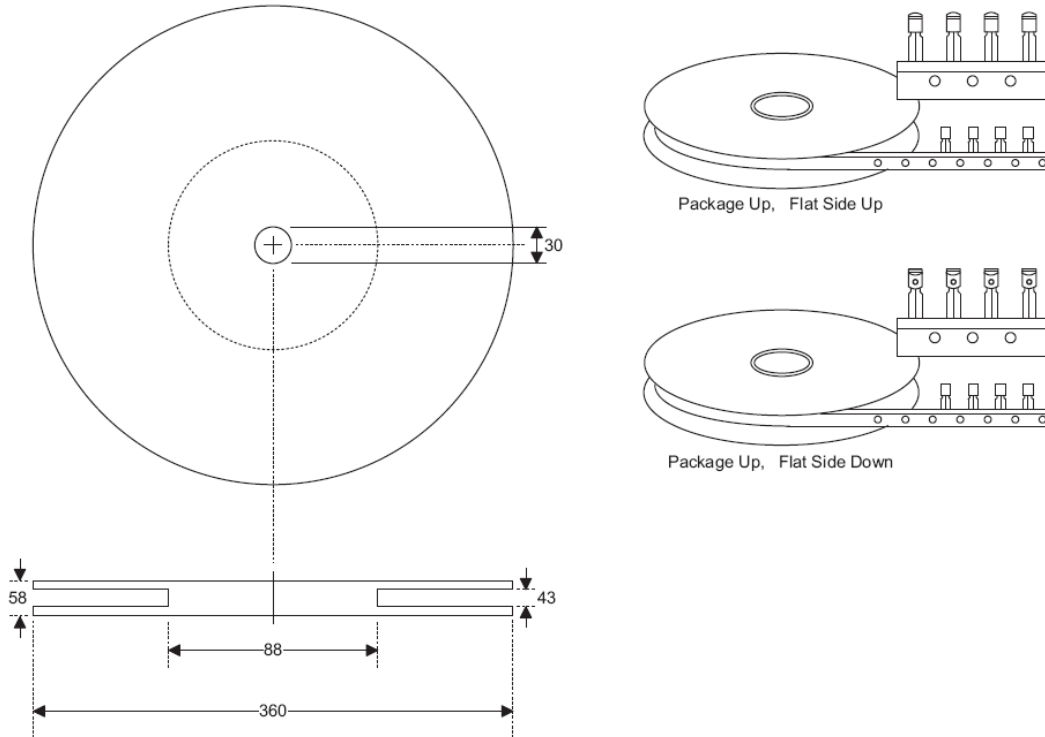

Reel Dimensions

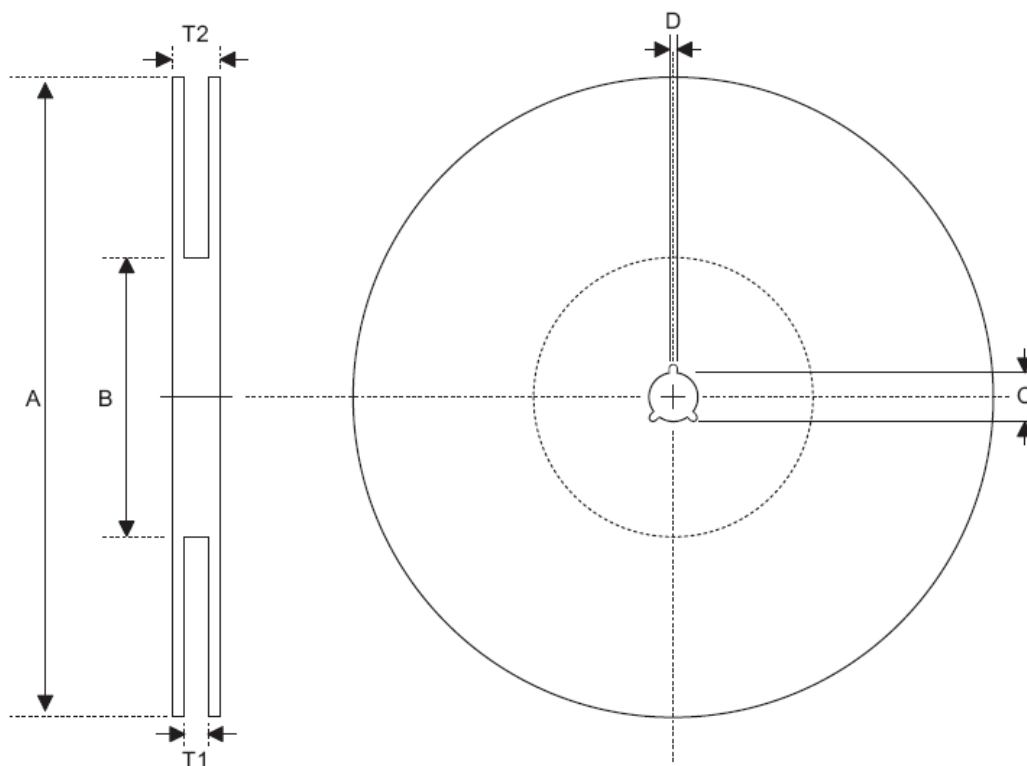

SOT89

Symbol	Description	Dimensions in mm
A	Reel Outer Diameter	180.0±1.0
B	Reel Inner Diameter	62.0±1.5
C	Spindle Hole Diameter	12.75 ^{+0.15/-0.00}
D	Key Slit Width	1.90±0.15
T1	Space Between Flange	12.4 ^{+0.2/-0.00}
T2	Reel Thickness	17.0 ^{+0.0/-0.4}

SOT23-5

Symbol	Description	Dimensions in mm
A	Reel Outer Diameter	178.0±1.0
B	Reel Inner Diameter	62.0±1.0
C	Spindle Hole Diameter	13.0±0.2
D	Key Slit Width	2.50±0.25
T1	Space Between Flange	8.4 ^{+1.5/-0.0}
T2	Reel Thickness	11.4 ^{+1.5/-0.0}

Carrier Tape Dimensions

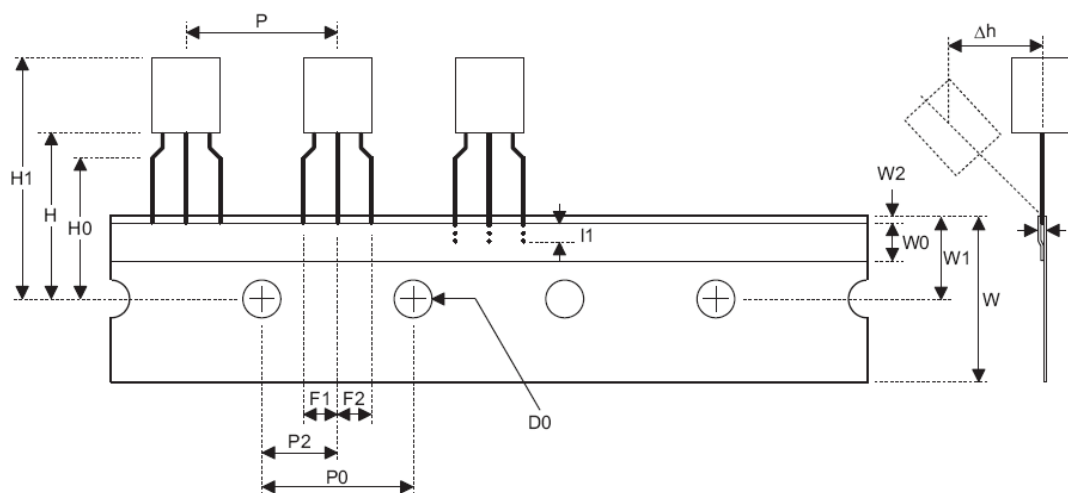

TO92

Symbol	Description	Dimensions in mm
I1	Taped Lead Length	(2.5)
P	Component Pitch	12.7±1.0
P ₀	Perforation Pitch	12.7±0.3
P ₂	Component to Perforation (Length Direction)	6.35±0.40
F ₁	Lead Spread	2.5 ^{+0.4/-0.1}
F ₂	Lead Spread	2.5 ^{+0.4/-0.1}
Δh	Component Alignment	0.0±0.1
W	Carrier Tape Width	18.0 ^{+1.0/-0.5}
W ₀	Hold-down Tape Width	6.0±0.5
W ₁	Perforation Position	9.0±0.5
W ₂	Hold-down Tape Position	(0.5)
H ₀	Lead Clinch Height	16.0±0.5
H ₁	Component Height	Less than 24.7
D ₀	Perforation Diameter	4.0±0.2
t	Taped Lead Thickness	0.7±0.2
H	Component Base Height	19.0±0.5

Note: Thickness less than 0.38_0.05mm~0.5mm

P0 Accumulated pitch tolerance: _1mm/20itches.

() Bracketed figures are for consultation only

Carrier Tape Dimensions

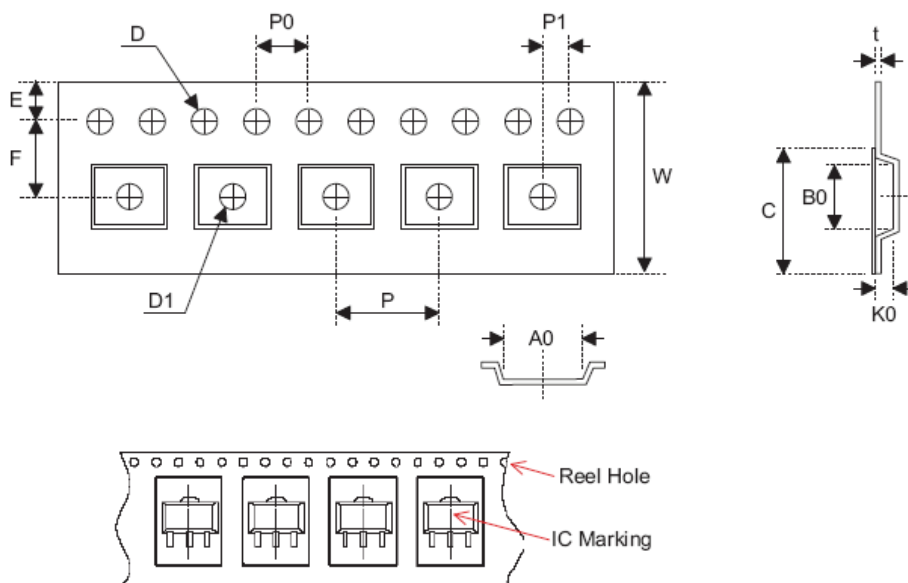

SOT89

Symbol	Description	Dimensions in mm
W	Carrier Tape Width	12.0 ^{+0.3/-0.1}
P	Cavity Pitch	8.0±0.1
E	Perforation Position	1.75±0.10
F	Cavity to Perforation (Width Direction)	5.50±0.05
D	Perforation Diameter	1.5 ^{+0.1/-0.0}
D1	Cavity Hole Diameter	1.5 ^{+0.1/-0.0}
P0	Perforation Pitch	4.0±0.1
P1	Cavity to Perforation (Length Direction)	2.0±0.1
A0	Cavity Length	4.8±0.1
B0	Cavity Width	4.5±0.1
K0	Cavity Depth	1.8±0.1
t	Carrier Tape Thickness	0.300±0.013
C	Cover Tape Width	9.3±0.1

SOT23-5

Symbol	Description	Dimensions in mm
W	Carrier Tape Width	8.0±0.3
P	Cavity Pitch	4.0±0.1
E	Perforation Position	1.75±0.10
F	Cavity to Perforation (Width Direction)	3.50±0.05
D	Perforation Diameter	1.5 ^{+0.1/-0.0}
D1	Cavity Hole Diameter	1.5 ^{+0.1/-0.0}
P0	Perforation Pitch	4.0±0.1
P1	Cavity to Perforation (Length Direction)	2.00±0.05
A0	Cavity Length	3.15±0.10
B0	Cavity Width	3.2±0.1
K0	Cavity Depth	1.4±0.1
t	Carrier Tape Thickness	0.20±0.03
C	Cover Tape Width	5.3±0.1