



GaAs MMIC I/Q UPCONVERTER 21 - 27 GHz

Typical Applications

The HMC815BLC5 is ideal for:

- Point-to-Point and Point-to-Multi-Point Radios
- Military Radar, EW & ELINT
- Satellite Communications
- Sensors

Features

- Conversion Gain: 12 dB
- Sideband Rejection: 25 dBc
- 2x LO to RF Isolation: 8 dB
- 2x LO to IF Isolation: 11 dB
- Output Third-Order Intercept (IP3): 27 dBm
- Output Power for 1 dB Compression (P1dB): 20 dBm
- 32 Lead 5x5mm SMT Ceramic Package

Functional Diagram

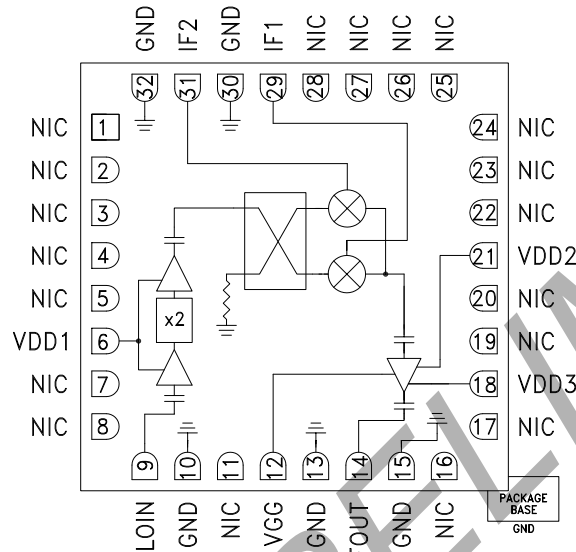

General Description

The HMC815BLC5 is a compact GaAs MMIC I/Q upconverter in a leadless RoHS compliant SMT package. This device provides a small signal conversion gain of 12 dB and 25 dBc of sideband rejection. The HMC815BLC5 utilizes a driver amplifier preceded by an I/Q mixer where the LO is driven by an active x2 multiplier. IF1 and IF2 mixer inputs are provided and an external 90° hybrid is needed to select the required sideband. The I/Q mixer topology reduces the need for filtering of the unwanted sideband. The HMC815BLC5 is a much smaller alternative to hybrid style single sideband upconverter assemblies and it eliminates the need for wire bonding by allowing the use of surface mount manufacturing techniques.

**Electrical Specifications, $T_A = +25^\circ\text{C}$,
IF = 2500 MHz, LO = 4 dBm, VDD1, 2, 3 = 4.5V, IDD1 = 90 mA, IDD2 + IDD3 = 270 mA [1][2]**

Parameter	Min.	Typ.	Max.	Units
Frequency Range	21		27	GHz
1x LO Frequency Range	10.5		14.5	GHz
IF Frequency Range	0		3.75	GHz
LO Drive Range	1		6	dBm
Conversion Gain	10	12		dB
Sideband Rejection	15	25		dBc
2x LO to RF Isolation		8		dB
2x LO to IF Input Isolation		11		dB
Output Third-Order Intercept (IP3)		27		dBm
Output Power for 1 dB Compression (P1dB)	17	20		dBm
Supply Current (IDD1)		95		mA
Supply Current (IDD2 + IDD3)		270		mA

[1] Unless otherwise noted all measurements performed as upconverter with lower sideband selected and external 90° IF hybrid at the IF ports.

[2] Adjust VGG between -2 V to 0 V to achieve IDD2 + IDD3 = 270 mA.

HMC815B* PRODUCT PAGE QUICK LINKS

Last Content Update: 02/23/2017

COMPARABLE PARTS

View a parametric search of comparable parts.

EVALUATION KITS

- HMC815B Evaluation Board

DOCUMENTATION

Data Sheet

- HMC815BLC5: GaAs MMIC I/Q Upconverter 21 to 27 GHz Preliminary Data Sheet

DESIGN RESOURCES

- HMC815B Material Declaration
- PCN-PDN Information
- Quality And Reliability
- Symbols and Footprints

DISCUSSIONS

View all HMC815B EngineerZone Discussions.

SAMPLE AND BUY

Visit the product page to see pricing options.

TECHNICAL SUPPORT

Submit a technical question or find your regional support number.

DOCUMENT FEEDBACK

Submit feedback for this data sheet.

Absolute Maximum Ratings

Drain Bias Voltage (VDD1, 2, 3)	5.5 V
Gate Bias Voltage Range (VGG)	-3 V to 0 V
IF Input Power	20 dBm
LO Drive	13 dBm
Continuous P _{diss} (T = 85°C) (derate (TBD) W / °C above 85 °C)	(TBD) mW
Thermal Resistance (R _{TH}) (junction to ground paddle)	(TBD) °C/W
Operating Temperature Range	-40°C to +85°C
Storage Temperature Range	-65°C to +150°C
ESD Sensitivity (HBM)	TBD



ELECTROSTATIC SENSITIVE DEVICE
OBSERVE HANDLING PRECAUTIONS

Outline Drawing

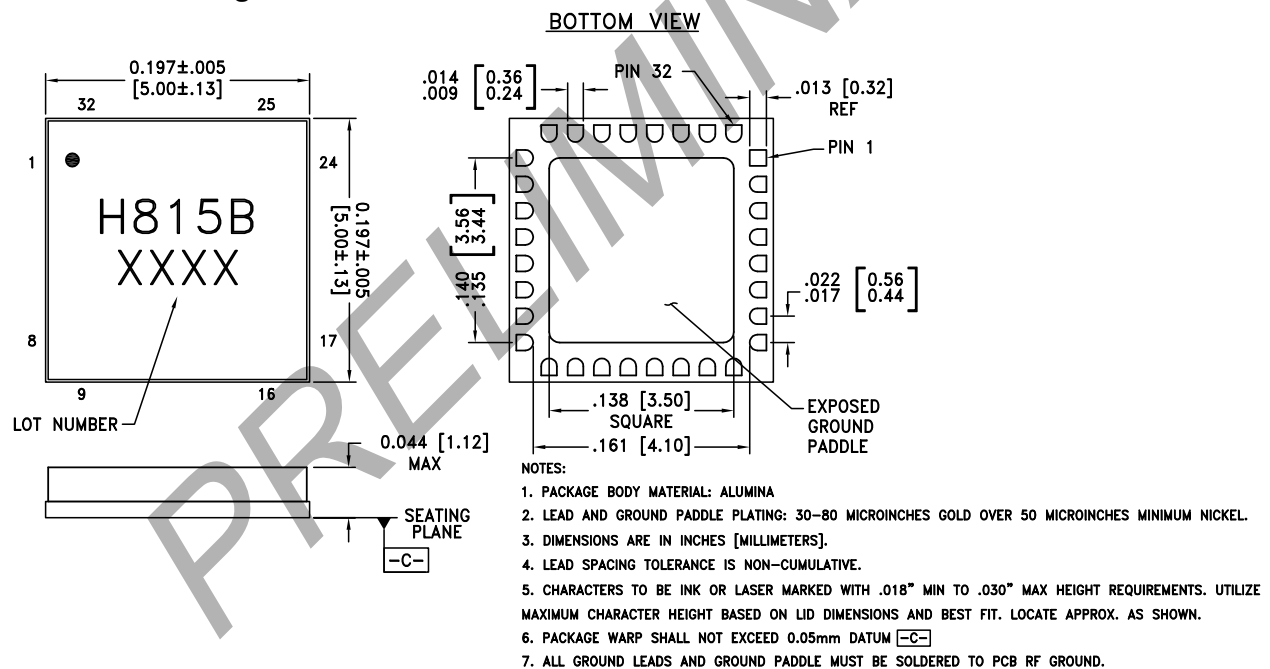

Package Information

Part Number	Package Body Material	Lead Finish	MSL Rating	Package Marking ^[2]
HMC815BLC5	Alumina, White	Gold over Nickel	MSL3 ^[1]	H815B XXXX

[1] Max peak reflow temperature of 260 °C

[2] 4-Digit lot number XXXX



Pin Descriptions

Pin Number	Function	Description	Interface Schematic
1 - 5, 7, 8, 11, 16, 17, 19, 20, 22 - 28	NIC	No Internal Connection. These pins are not connected internally.	
6	VDD1	Power supply voltage for the multiplier. See application circuit for required external components.	
9	LOIN	Local Oscillator Input. This pin is ac coupled and matched to 50 Ohms.	
10, 13, 15, 30, 32	GND	Ground Connect. These pins and package bottom must be connected to RF/dc ground.	
12	VGG	Gate Bias for the RF amplifier. See application circuit for required external components.	
14	RFOUT	Radio Frequency Output. This pin is ac coupled and matched to 50 Ohms.	
18, 21	VDD3, VDD2	Power supply voltage for RF amplifier. See application circuit for required external components.	
29	IF1	First and Second Quadrature Intermediate Frequency input pins. For applications not requiring operation to dc, an off chip dc blocking capacitor should be used. For operation to dc these pins must not source/sink more than 3 mA of current or part non function and possible part failure will result.	
31	IF2		



Typical Application

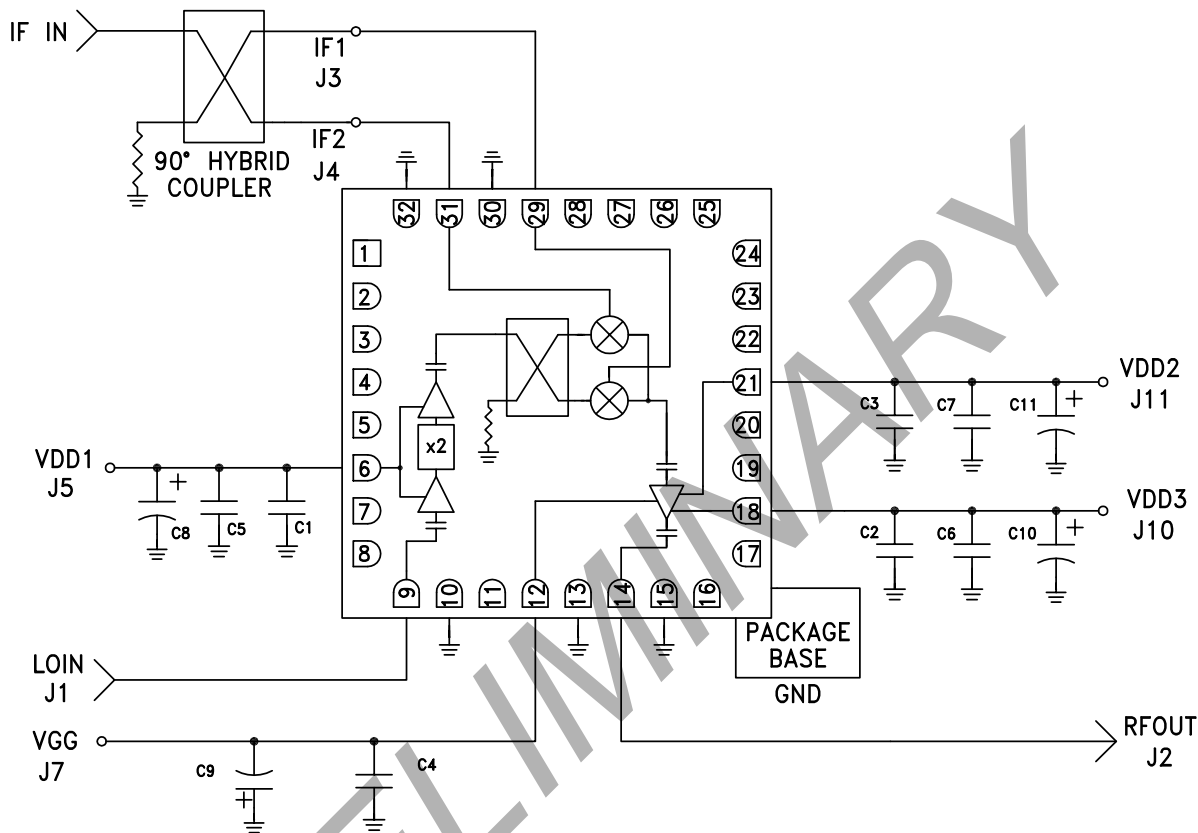

C1 - C3	100 pF
C4 - C7	1000 pF
C8 - C11	2.2 μ F

Evaluation PCB

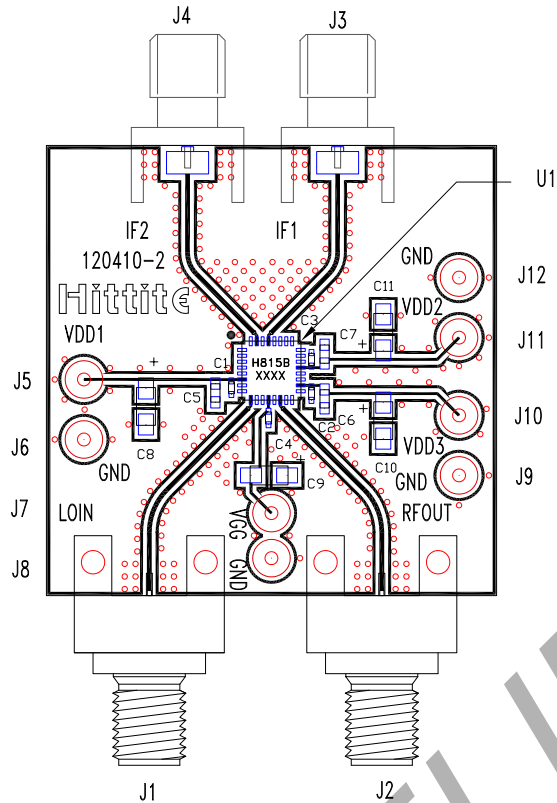

Evaluation Order Information

Item	Contents	Part Number
Evaluation PCB Only	HMC815BLC5 Evaluation PCB	EV1HMC815BLC5 [1]

[1] Reference this number when ordering Evaluation PCB Only

List of Materials for Evaluation PCB

Item	Description
J1, J2	PCB Mount 2.99mm Connector
J3, J4	PCB Mount SMA Connector
J5 - J12	DC Pin
C1 - C3	100 pF Capacitor, 0402 Pkg.
C4	1000 pF Capacitor, 0402 Pkg.
C5 - C7	1000 pF Capacitor, 0603 Pkg.
C8 - C11	2.2 μF Tantalum Capacitor Case A
U1	HMC815BLC5 Upconverter
PCB [2]	120410 Evaluation Board

[1] Reference this number when ordering complete evaluation PCB

[2] Circuit Board Material: Arlon 25FR, FR4 or Rogers 4350

The circuit board used in the final application should use RF circuit design techniques. Signal lines should have 50 Ohm impedance while the package ground leads and exposed paddle should be connected directly to the ground plane similar to that shown. A sufficient number of via holes should be used to connect the top and bottom ground planes. The evaluation circuit board shown is available from Analog Devices upon request.



Notes:

PRELIMINARY