

GENERAL DESCRIPTION

The HMD4M32M2E is a 4M x 32 bit dynamic RAM high-density memory module. The module consists of two CMOS 4M x 16 bit DRAMs in 50-pin TSOP packages mounted on a 72-pin. A 0.1 or 0.22uF decoupling capacitor is mounted on the printed circuit board for each DRAM components. The module is a single In-line memory module with edge connections and is intended for mounting in to 72-pin edge connector sockets. All module components may be powered from a single 5V DC power supply. All inputs and outputs are TTL-compatible.

FEATURES

- w Part Identification
 HMD4M32M2E----4K Cycles/64ms Ref. Solder
 HMD4M32M2EG- 4K Cycles/64ms Ref. Gold
- w Access times : 50, 60ns
- w High-density 16MByte design
- w Single +5V± 0.5V power supply
- w JEDEC standard pinout
- w EDO Mode operation
- w TTL compatible inputs and outputs
- w FR4-PCB design

PIN ASSIGNMENT

PIN	SYMBOL	PIN	SYMBOL	PIN	SYMBOL
1	Vss	25	DQ22	49	DQ8
2	DQ0	26	DQ7	50	DQ24
3	DQ16	27	DQ23	51	DQ9
4	DQ1	28	A7	52	DQ25
5	DQ17	29	A11	53	DQ10
6	DQ2	30	Vcc	54	DQ26
7	DQ18	31	A8	55	DQ11
8	DQ3	32	A9	56	DQ27
9	DQ19	33	NC	57	DQ12
10	Vcc	34	NC	58	DQ28
11	NC	35	NC	59	Vcc
12	A0	36	NC	60	DQ29
13	A1	37	NC	61	DQ13
14	A2	38	NC	62	DQ30
15	A3	39	Vss	63	DQ14
16	A4	40	/CAS0	64	DQ31
17	A5	41	/CAS2	65	DQ15
18	A6	42	/CAS3	66	NC
19	A10	43	/CAS1	67	PD1
20	DQ4	44	/RAS0	68	PD2
21	DQ20	45	NC	69	PD3
22	DQ5	46	NC	70	PD4
23	DQ21	47	/WE	71	NC
24	DQ6	48	NC	72	Vss

OPTIONS

MARKING

- w Timing
 50ns access -5
 60ns access -6
- w Packages
 72-pin SIMM M

PRESENCE DETECT PINS

Pin	50ns	60ns
PD1	Vss	Vss
PD2	NC	NC
PD3	Vss	NC
PD4	Vss	NC

PERFORMANCE RANGE

Speed	tRAC	tCAC	tRC	tHPC
5	50ns	13ns	90ns	26ns
6	60ns	15ns	110ns	30ns

FUNCTIONAL BLOCK DIAGRAM

www.DataSheet4U.com

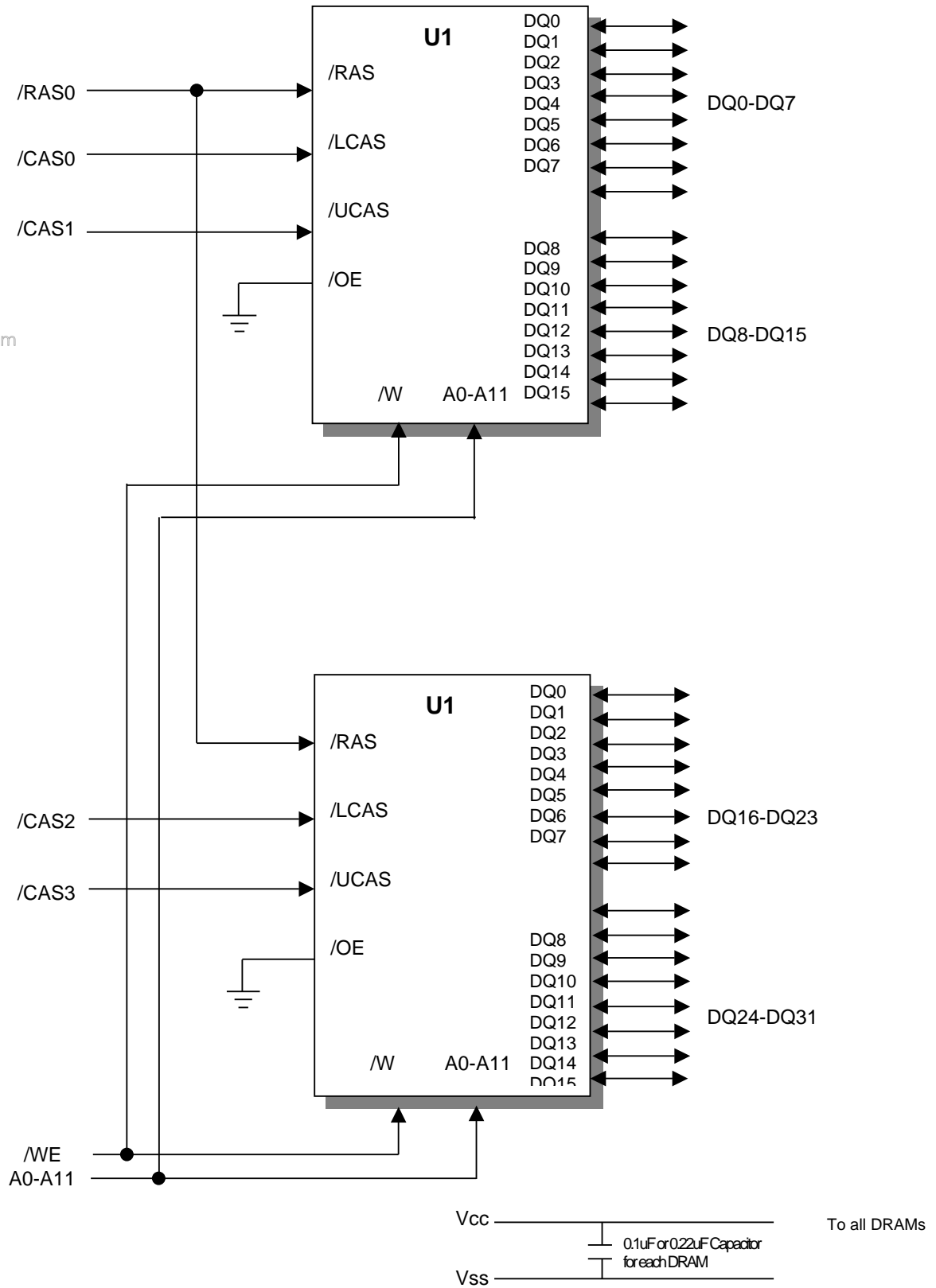

ABSOLUTE MAXIMUM RATINGS

PARAMETER	SYMBOL	RATING
Voltage on Any Pin Relative to V _{SS}	V _{IN,OUT}	-1V to 7.0V
Voltage on V _{CC} Supply Relative to V _{SS}	V _{CC}	-1V to 7.0V
Power Dissipation	P _D	2W
Storage Temperature	T _{STG}	-55°C to 150°C
Short Circuit Output Current	I _{OS}	50mA

w Permanent device damage may occur if " Absolute Maximum Ratings" are exceeded. Functional operation should be restricted to the conditions as detailed in the operational sections of this data sheet. Exposure to absolute maximum rating conditions for extended periods may affect device reliability.

RECOMMENDED DC OPERATING CONDITIONS

(Voltage reference to V_{SS}, T_A=0 to 70 ° C)

PARAMETER	SYMBOL	MIN	TYP.	MAX	UNIT
Supply Voltage	V _{CC}	4.5	5.0	5.5	V
Ground	V _{SS}	0	0	0	V
Input High Voltage	V _{IH}	2.4	-	V _{CC} +1	V
Input Low Voltage	V _{IL}	-1.0	-	0.8	V

DC AND OPERATING CHARACTERISTICS

SYMBOL	SPEED	MIN	MAX	UNITS
I _{CC1}	-5	-	880	mA
	-6	-	800	mA
I _{CC2}	-5	-	16	mA
	-6	-	16	mA
I _{CC3}	-5	-	880	mA
	-6	-	800	mA
I _{CC4}	-5	-	880	mA
	-6	-	800	mA
I _{CC5}	-5	-	8	mA
	-6	-	8	mA
I _{CC6}	-5	-	880	mA
	-6	-	800	mA
I _{I(L)}		-40	40	μA
I _{O(L)}		-5	5	μA
V _{OH}		2.4	-	V
V _{OL}		-	0.4	V

I_{CC1} : Operating Current * (/RAS , /CAS , Address cycling @t_{RC}=min.)

I_{CC2} : Standby Current (/RAS=/CAS=V_{IH})

I_{CC3} : /RAS Only Refresh Current * (/CAS= V_{IH} , /RAS, Address cycling @ $t_{RC}=\min$)

I_{CC4} : EDO Mode Current * (/RAS= V_{IL} , /CAS, Address cycling @ $t_{PC}=\min$)

I_{CC5} : Standby Current (/RAS=/CAS= $V_{CC}-0.2V$)

I_{CC6} : /CAS-Before-/RAS Refresh Current * (/RAS and /CAS cycling @ $t_{RC}=\min$)

I_{IL} : Input Leakage Current (Any input $0V \leq V_{IN} \leq 6.5V$, all other pins not under test = $0V$)

I_{OL} : Output Leakage Current (Data out is disabled, $0V \leq V_{OUT} \leq 5.5V$)

V_{OH} : Output High Voltage Level ($I_{OH} = -5mA$)

V_{OL} : Output Low Voltage Level ($I_{OL} = 4.2mA$)

* **NOTE:** I_{CC1} , I_{CC3} , I_{CC4} and I_{CC6} are dependent on output loading and cycle rates. Specified values are obtained with the output open. I_{CC} is specified as an average current. In I_{CC1} and I_{CC3} , address can be changed maximum once while /RAS= V_{IL} . In I_{CC4} , address can be changed maximum once within one page mode cycle.

CAPACITANCE ($T_A=25^\circ C$, $V_{CC} = 5V$, $f = 1Mz$)

DESCRIPTION	SYMBOL	MIN	MAX	UNITS
Input Capacitance (A0-A10)	C_{IN1}	-	64	pF
Input Capacitance (/W)	C_{IN2}	-	70	pF
Input Capacitance (/RAS0)	C_{IN3}	-	42	pF
Input Capacitance (/CAS0-/CAS3)	C_{IN4}	-	30	pF
Input/Output Capacitance (DQ0-31)	C_{DQ1}	-	17	pF

AC CHARACTERISTICS ($0^\circ C \leq T_A \leq 70^\circ C$, $V_{CC} = 5V \pm 10\%$, See notes 1,2.)

STANDARD OPERATION	SYMBOL	-5		-6		UNIT
		MIN	MAX	MIN	MAX	
Random read or write cycle time	t_{RC}	90		110		ns
Access time from /RAS	t_{RAC}		50		60	ns
Access time from /CAS	t_{CAC}		13		15	ns
Access time from column address	t_{AA}		25		30	ns
/CAS to output in Low-Z	t_{CLZ}	3		3		ns
Output buffer turn-off delay from /CAS	t_{CEZ}	3	13	3	15	ns
Transition time (rise and fall)	t_T	2	50	2	50	ns
/RAS precharge time	t_{RP}	30		40		ns
/RAS pulse width	t_{RAS}	50	10K	60	10K	ns
/RAS hold time	t_{RSH}	13		15		ns
/CAS hold time	t_{CSH}	38		45		ns
/CAS pulse width	t_{CAS}	8	10K	10	10K	ns
/RAS to /CAS delay time	t_{RCD}	20	37	20	45	ns
/RAS to column address delay time	t_{RAD}	15	25	15	30	ns
/CAS to /RAS precharge time	t_{CRP}	5		5		ns

Row address set-up time	t_{ASR}	0		0		ns
Row address hold time	t_{RAH}	10		10		ns
Column address set-up time	t_{ASC}	0		0		ns
Column address hold time	t_{CAH}	8		10		ns
Column address hold referenced to /RAS	t_{AR}	40		45		ns
Column Address to /RAS lead time	t_{RAL}	25		30		ns
Read command set-up time	t_{RCS}	0		0		ns
Read command hold referenced to /CAS	t_{RCH}	0		0		ns
Read command hold referenced to /RAS	t_{RRH}	0		0		ns
Write command hold time	t_{WCH}	10		10		ns
Write command hold referenced to /RAS	t_{WCR}	40		45		ns
Write command pulse width	t_{WP}	10		10		ns
Write command to /RAS lead time	t_{RWL}	13		15		ns
Write command to /CAS lead time	t_{CWL}	8		10		ns
Data-in set-up time	t_{DS}	0		0		ns
Data-in hold time	t_{DH}	8		10		ns
Data-in hold referenced to /RAS	t_{DHR}	40		45		ns
Refresh period	t_{REF}		64		64	ns
Write command set-up time	t_{WCS}	0		0		ns
/CAS to /W delay time	t_{CWD}	36		40		ns
/RAS to /W delay time	t_{RWD}	73		85		ns
/CAS precharge(C-B-R counter test)	t_{CPT}	20		20		ns
Column address to /W delay time	t_{AWD}	48		55		ns
Access time from /CAS precharge	t_{CPA}		30		35	ns
/CAS precharge time (Hyper Page cycle)	t_{CP}	8		10		ns
/RAS pulse width (Hyper Page cycle)	t_{RASP}	50	200K	60	200K	ns
/W to /RAS precharge time (C-B-R refresh)	t_{WRP}	10		10		ns
/W to /RAS hold time (C-B-R refresh)	t_{WRH}	10		10		ns

NOTES

1. An initial pause of 200 μ s is required after power-up followed by any 8 /RAS-only or /CAS-before-/RAS refresh cycles before proper device operation is achieved.
2. $V_{IH(min)}$ and $V_{IL(max)}$ are reference levels for measuring timing of input signals. Transition times are measured between $V_{IH(min)}$ and $V_{IL(max)}$ and are assumed to be 5ns for all inputs.
3. Measured with a load equivalent to 1TTL loads and 100pF
4. Operation within the $t_{RCD(max)}$ limit insures that $t_{RAC(max)}$ can be met. $t_{RCD(max)}$ is specified as a reference point only. If t_{RCD} is greater than the specified $t_{RCD(max)}$ limit, then access time is controlled exclusively by t_{CAC} .
5. Assumes that $t_{RCD} \geq t_{RCD(max)}$
6. t_{AR} , t_{WCR} , t_{DHR} are referenced to $t_{RAD(max)}$
7. This parameter defines the time at which the output achieves the open circuit condition and is not referenced to V_{OH}

or V_{OL} .

8. t_{WCS} , t_{RWD} , t_{CWD} and t_{AWD} are non restrictive operating parameter.

They are included in the data sheet as electrical characteristic only. If $t_{WCS} \geq t_{WCS(min)}$ the cycle is an early write cycle and the data out pin will remain high impedance for the duration of the cycle.

9. Either t_{RCH} or t_{RRH} must be satisfied for a read cycle.

10. These parameters are referenced to the $/CAS$ leading edge in early write cycles and to the $/W$ leading edge in read-write cycles.

11. Operation within the $t_{RAD(max)}$ limit insures that $t_{RAC(max)}$ can be met. $t_{RAD(max)}$ is specified as a reference point only. If t_{RAD} is greater than the specified $t_{RAD(max)}$ limit, then access time is controlled by t_{AA} .

TIMING DIAGRAM

www.DataSheet4U.com

Please refer to attached timing diagram chart (I)

PACKAGING INFORMATION

SIMM Design

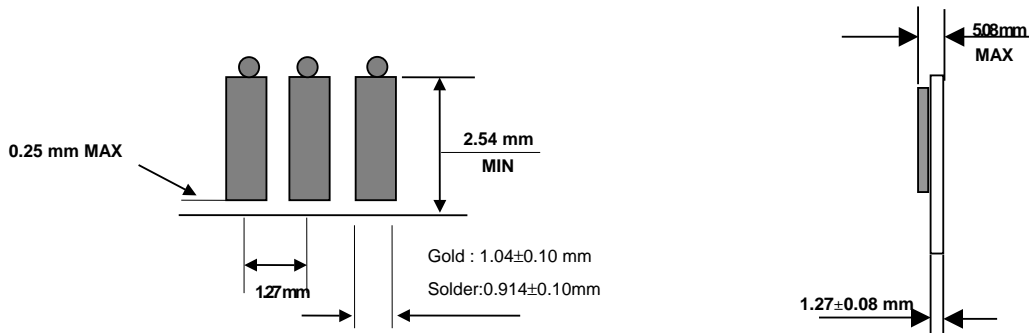
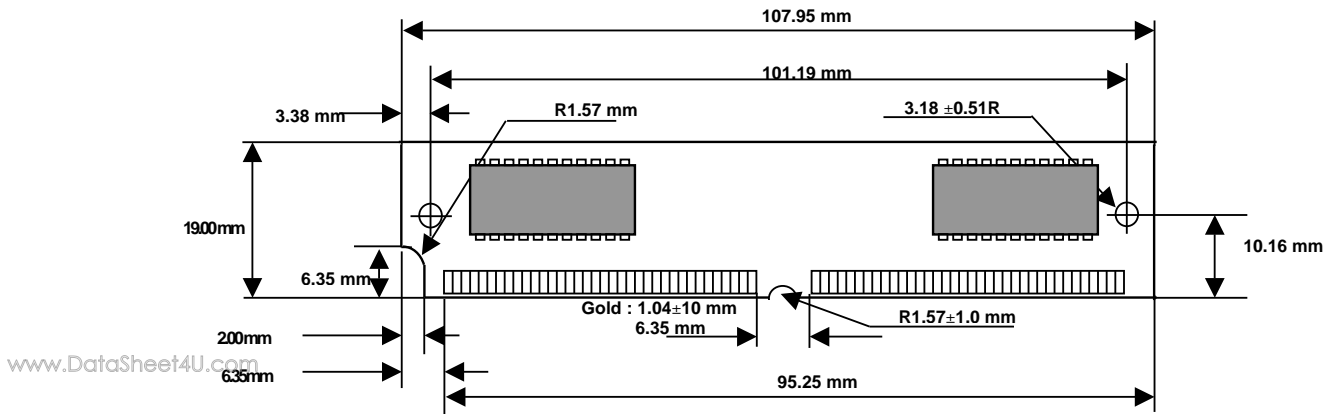

ORDERING INFORMATION

Part Number	Density	Org.	Package	Refresh Cycle	Vcc	SPEED
HMD4M32M2EG-5	16MByte	4MX 32bit	72 Pin-SIMM	4,096 Cycles 64ms Ref.	5.0V	50ns
HMD4M32M2EG-6	16MByte	4MX 32bit	72 Pin-SIMM	4,096 Cycles 64ms Ref.	5.0V	60ns