



5.0 or 3.3V, 64K bit (8 Kbit x 8) TIMEKEEPER NVSRAM

Part No. HMNR88D(V)

GENERAL DESCRIPTION

The HMNR88D(V) TIMEKEEPER SRAM is a 8Kbit x 8 non-volatile static RAM and real time clock organized as 8,192 words by 8 bits. The special DIP package provides a fully integrated battery back-up memory and real time clock solution. The HMNR88D(V) directly replaces industry standard 8Kbit x 8 SRAMs. It also provides the non-volatility of Flash without any requirement for special WRITE timing or limitations on the number of WRITES that can be performed.

FEATURES

- INTEGRATED LOW POWER SRAM, REAL TIME CLOCK, POWER-FAIL CONTROL CIRCUIT, BATTERY and CRYSTAL
- BCD CODED YEAR, MONTH, DAY, DATE, HOURS, MINUTES, and SECONDS
- AUTOMATIC POWER-FAIL CHIP DESELECT and WRITE PROTECTION VOLTAGES :
(V_{PFD} = Power-fail Deselect Voltage)
 - HMNR88D(V) : $V_{CC} = 4.5$ to $5.5V$
 $4.2V \leq V_{PFD} \leq 4.5V$
 - HMNR88D(V)V : $V_{CC} = 3.0$ to $3.6V$
 $2.7V \leq V_{PFD} \leq 3.0V$
- CONVENTIONAL SRAM OPERATION : UNLIMITED WRITE CYCLES
- SOFTWARE CONTROLLED CLOCK CALIBRATION FOR HIGH ACCURACY APPLICATIONS
- 10 YEARS OF DATA RETENTION and CLOCK OPERATION IN THE ABSENCE OF POWER PIN and FUNCTION COMPATIBLE WITH INDUSTRY STANDARD 8K x 8 SRAMS
- SELF-CONTAINED BATTERY and CRYSTAL IN DIP PACKAGE

OPTIONS

- ◆ Timing
 - 70 ns
 - 85 ns

MARKING

-70
-85

PIN ASSIGNMENT

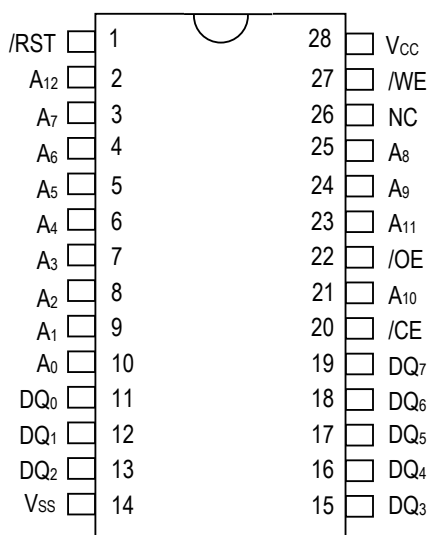

28-pin Encapsulated Package

FUNCTIONAL DESCRIPTION

The HMNR88D(V) is a full function, year 2000 compliant (Y2KC), real-time clock/calendar (RTC) and 8k x 8 non-volatile static RAM. User access to all registers within the HMNR88D(V) is accomplished with a byte-wide interface. The Real-time clock (RTC) information and control bits reside in the sixteen upper most RAM locations. The RTC registers contain century, year, month, date, day, hours, minutes, and seconds data in 24-hour BCD format. Corrections for the date of each month and leap year are made automatically. The RTC clock registers are double buffered to avoid access of incorrect data that can occur during clock update cycles. The double buffered system also prevents time loss as the timekeeping countdown continues unabated by access to time register data. The HMNR88D(V) also contains its own power-fail circuitry which deselected the device when the V_{CC} supply is in an out of tolerance condition. This feature prevents loss of data from unpredictable system operation brought on by low V_{CC} as errant access and update cycles are avoided.

BLOCK DIAGRAM

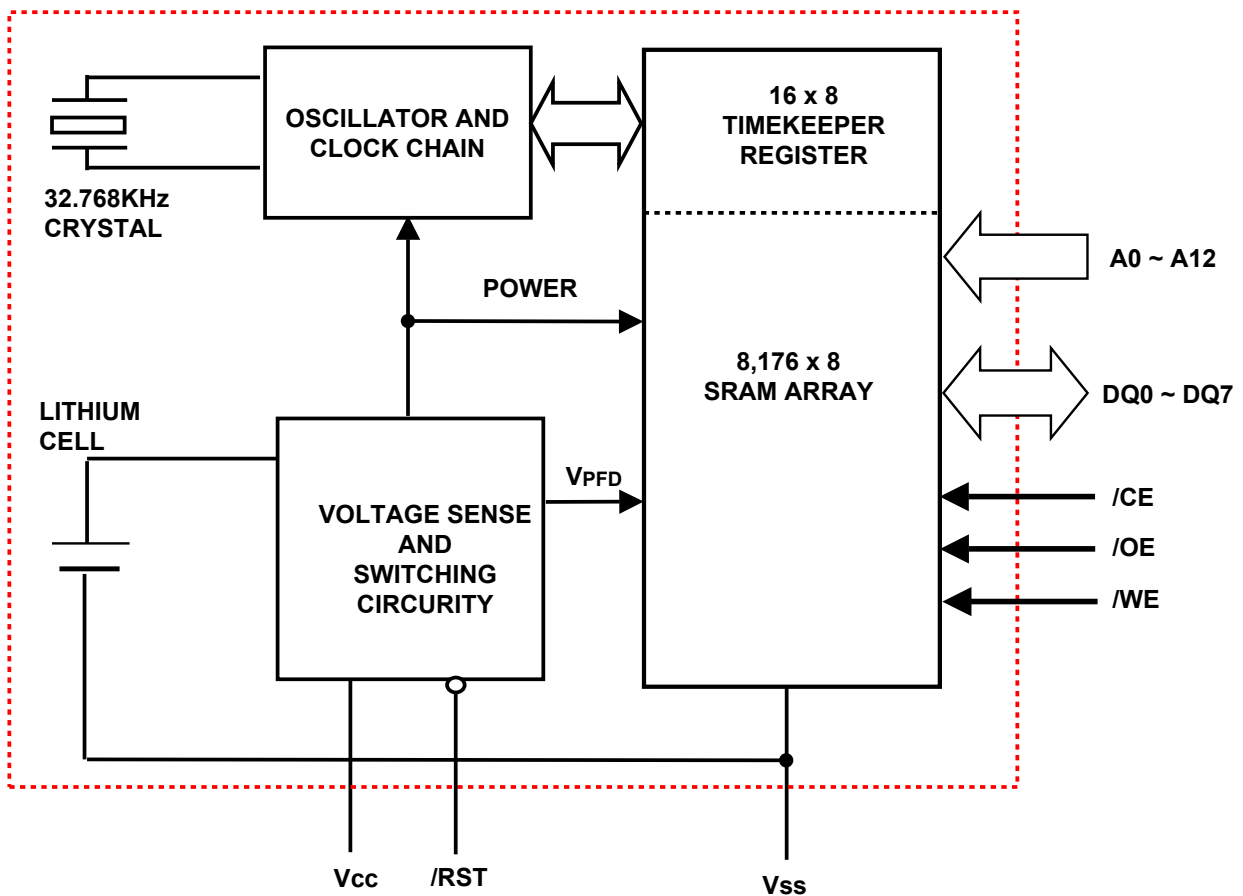

A0-A12 : Address Input	/WE : Write Enable
/CE : Chip Enable, Low Active	/OE : Output Enable
DQ0-DQ7 : Data In / Data Out	V_{CC} : Power (+5V or +3.3V)
NC : No Connection	V_{SS} : Ground
/RST : Reset Output (Open drain)	

Absolute Maximum Ratings

Symbol	Parameter	Value	Unit	
T_A	Ambient Operating Temperature	0 to 70	°C	
T_{STG}	Storage Temperature (Vcc Off, Oscillator Off)	-40 to 70	°C	
$T_{SLD}^{(1)}$	Lead Solder Temperature for 10 seconds	260	°C	
V_{IO}	Input or Output Voltage	-0.3 to Vcc+0.3	V	
V_{CC}	Supply Voltage	HMNR88D	4.5 to 5.5	V
		HMNR88DV	3.0 to 3.6	V
I_O	Output Current	20	mA	
P_D	Power Dissipation	1	W	

Note : Permanent device damage may occur if Absolute Maximum Ratings are exceeded.

Functional operation should be restricted to the Recommended DC Operating Conditions detailed in this data sheet.

Exposure to higher than recommended voltage for extended periods of time could affect device reliability.

(1) Soldering temperature not to exceed 260°C for 10 seconds (Total thermal budget not to exceed 150°C for longer than 30 seconds).

Caution : Negative undershoots below -0.3V are not allowed on any pin while in the Battery Back-up mode.

Operating and AC Measurement Conditions

Parameter	HMNR88D	HMNR88DV	Unit
V_{CC} Supply Voltage	4.5 to 5.5	3.0 to 3.6	V
Ambient Operating Temperature	0 to 70	0 to 70	°C
Load Capacitance (C_L)	100	50	pS
Input Rise and Fall Times	≤ 5	≤ 5	nS
Input Pulse Voltages	0 to 3	0 to 3	V
Input and Output Timing Ref. Voltages	1.5	1.5	V

AC Measurement Load Circuit

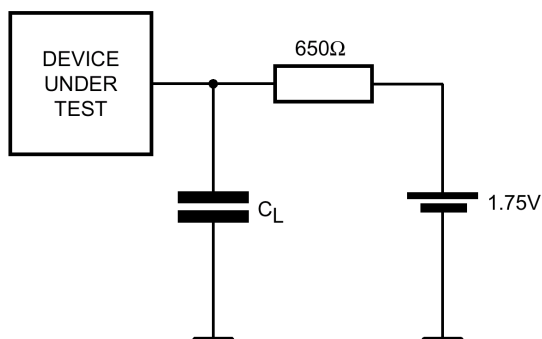

C_L includes JIG capacitance

Note : 50pF for HMNR88DV

Capacitance

Symbol	Parameter ^(1,2)	Min	Max	Unit
C_{IN}	Input Capacitance		10	pF
$C_{OUT}^{(3)}$	Input/Output Capacitance		10	pF

Note : Effective capacitance measured with power supply at 5V (HMNR88D) or 3.3V (HMNR88DV). Sampled only, not 100% tested. At 25°C, f = 1MHz. Outputs deselected.

DC Characteristics

Symbol	Parameter	Test Condition ⁽¹⁾	HMNR88D			HMNR88DV			Unit
			Min	Typ	Max	Min	Typ	Max	
I_{LI}	Input Leakage Current	$0V \leq V_{IN} \leq V_{CC}$			±1			±1	uA
$I_{LO}^{(2)}$	Output Leakage Current	$0V \leq V_{OUT} \leq V_{CC}$			±1			±1	uA
I_{CC}	Supply Current	Outputs open		8	15		4	10	mA
I_{CC1}	Supply Current (Standby) TTL	$/CE=V_{IH}$			5			3	mA
I_{CC2}	Supply Current (Standby) CMOS	$/CE=V_{CC}-0.2$			3			2	mA
I_{BAT}	Battery Current OSC ON			575	800		575	800	nA
	Battery Current OSC OFF			100				100	nA
V_{IL}	Input Low Voltage		-0.3		0.8	-0.3		0.8	V
V_{IH}	Input High Voltage		2.2		VCC+ 0.3	2.0		VCC+ 0.3	V
V_{OL}	Output Low Voltage	$I_{OL}=2.1mA$			0.4			0.4	V
	Output Low Voltage (open drain) (4)	$I_{OL}=10mA$			0.4			0.4	V
V_{OH}	Output High Voltage	$I_{OH}=-1.0mA$	2.4			2.4			V
V_{OHB}	V_{OH} Battery Back-up	$I_{OUT2}=-1.0uA$	2.0		3.6	2.0		3.6	V
I_{OUT1}	V_{OUT} Current (Active)	$V_{OUT1} > V_{CC}-0.3$			100			70	mA
I_{OUT2}	V_{OUT} Current (Battery Back-up)	$V_{OUT2} > V_{BAT}-0.3$			100			100	uA
V_{PFD}	Power-fail Deselect Voltage		4.1	4.35	4.5	2.7	2.9	3.0	V
V_{SO}	Battery Back-up Switchover Voltage			3.0			$V_{PFD}-100$ mV		V
V_{BAT}	Battery Voltage			3.0			3.0		V

Note: 1. Valid for Ambient Operating Temperature: $T_A = 0$ to 70°C or 40 to 85°C ;

$V_{CC} = 4.5$ to $5.5V$ or 3.0 to $3.6V$ (except where noted).

2. Outputs deselected.

OPERATING MODES

The 28-pin, 600mil DIP Hybrid houses a controller chip, SRAM, quartz crystal, and a long life lithium button cell in a single package. The clock locations contain the year, month, date, day, hour, minute, and second in 24 hour BCD format. Corrections for 28, 29 (leap year-compliant until the year 2100), 30, and 31 day months are made automatically. Byte 1FF8h is the clock control register. This byte controls user access to the clock information and also stores the clock calibration setting. The seven clock bytes (1FFFh-1FF9h) are not the actual clock counters, they are memory locations consisting of READ/WRITE memory cells within the static RAM array. The HMNR88D(V) includes a clock control circuit which updates the clock bytes with current information once per second. The information can be accessed by the user in the same manner as any other location in the static memory array. The HMNR88D(V) also has its own Power-Fail Detect circuit. This control circuitry constantly monitors the supply voltage for an out of tolerance condition.

When V_{CC} is out of tolerance, the circuit write protects the TIMEKEEPER register data and SRAM, providing data security in the midst of unpredictable system operation. As V_{CC} falls, the control circuitry automatically switches to the battery, maintaining data and clock operation until valid power is restored.

Operating Modes

Mode	VCC	/CE	/OE	/WE	DQ7 – DQ0	Power
Deselect	4.5V to 5.5V or 3.0V to 3.6V	VIH	X	X	High-Z	Standby
WRITE		VIL	X	VIL	DIN	Active
READ		VIL	VIL	VIH	DOUT	Active
READ		VIL	VIH	VIH	High	Active
Deselect	V_{SO} to V_{PFD} (min)	X	X	X	High	CMOS Standby
Deselect	$\leq V_{SO}$ (1)	X	X	X	High	Battery Back-up

Note : X = V_{IH} or V_{IL} ; V_{SO} = Battery Back-up Switchover Voltage.

READ Mode

The HMNR88D(V) is in the READ Mode whenever /WE (WRITE Enable) is high and /CE (Chip Enable) is low. The unique address specified by the 15 Address Inputs defines which one of the 32,768 bytes of data is to be accessed. Valid data will be available at the Data I/O pins within Address Access Time (t_{AVQV}) after the last address input signal is stable, providing the /CE and /OE access times are also satisfied. If the /CE and /OE access times are not met, valid data will be available after the latter of the Chip Enable Access Times (t_{ELQV}) or Output Enable Access Time (t_{GLQV}). The state of the eight three-state Data I/O signals is controlled by /CE and /OE. If the outputs are activated before t_{AVQV} , the data lines will be driven to an indeterminate state until t_{AVQV} . If the Address Inputs are changed while /CE and /OE remain active, output data will remain valid for Output Data Hold Time (t_{AXQX}) but will go indeterminate until the next Address Access.

READ Mode AC Waveforms

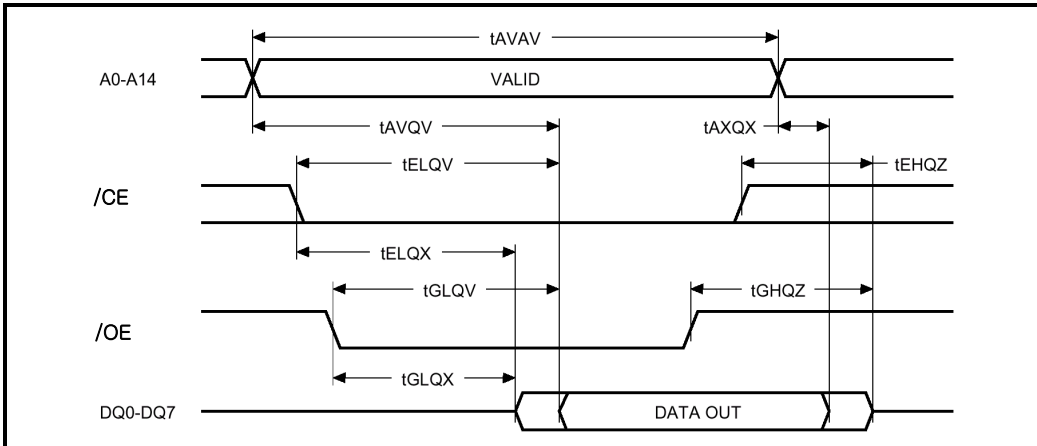

Note : /WE = High.

READ Mode AC Characteristics

Symbol	Parameter	HMNR88D		HMNR88D(V)V		Unit
		-70		-85		
		Min	Max	Min	Max	
t_{AVAV}	READ Cycle Time	70		85		nS
t_{AVQV}	Address Valid to Output Valid		70		85	nS
t_{ELQV}	Chip Enable Low to Output Valid		70		85	nS
t_{GLQV}	Output Enable Low to Output Valid		25		35	nS
$t_{ELOX}^{(2)}$	Chip Enable Low to Output Transition	5		5		nS
$t_{GLQX}^{(2)}$	Output Enable Low to Output Transition	0		0		nS
$t_{EHQZ}^{(2)}$	Chip Enable High to Output Hi-Z		20		25	nS
$t_{GHQZ}^{(2)}$	Output Enable High to Output Hi-Z		20		25	nS
t_{AXQX}	Address Transition to Output Transition	5		5		nS

Note: 1. Valid for Ambient Operating Temperature: $T_A = 0$ to 70°C ; $V_{CC} = 4.5$ to 5.5V or 3.0 to 3.6V (except where noted).
 2. $C_L = 5\text{pF}$.

WRITE Mode

The HMNR88D(V) is in the WRITE Mode whenever /WE (WRITE Enable) and /CE (Chip Enable) are low state after the address inputs are stable. The start of a WRITE is referenced from the latter occurring falling edge of /WE or /CE. A WRITE is terminated by the earlier rising edge of /WE or /CE. The addresses must be held valid throughout the cycle. /CE or /WE must return high for a minimum of t_{EHAX} from Chip Enable or t_{WHAX} from WRITE Enable prior to the initiation of another READ or WRITE cycle. Data-in must be valid t_{DVWH} prior to the end of WRITE and remain valid for t_{WHDX} afterward. /OE should be kept high during WRITE cycles to avoid bus contention; although, if the output bus has been activated by a low on /CE and /OE a low on /WE will disable the outputs t_{WLQZ} after /WE falls.

WRITE AC Waveforms, WRITE Enable Controlled

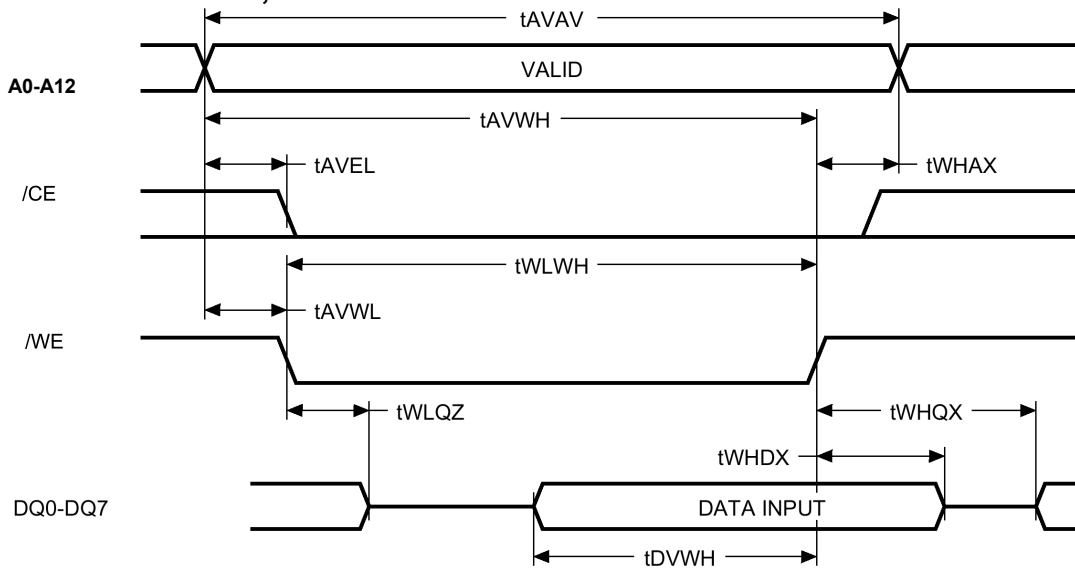

WRITE AC Waveforms, Chip Enable Controlled

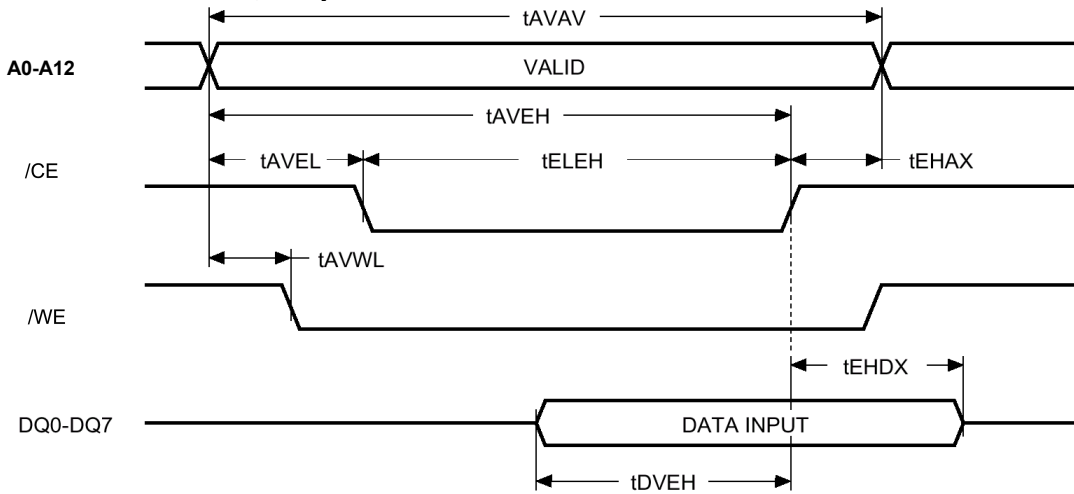

WRITE Mode AC Characteristics

Symbol	Parameter ⁽¹⁾	HMNR88D		HMNR88DV		Unit
		-70		-85		
		Min	Max	Min	Max	
t_{AVAV}	WRITE Cycle Time	70		85		nS
t_{AVWL}	Address Valid to WRITE Enable Low	0		0		nS
t_{AVEL}	Address Valid to Chip Enable Low	0		0		nS
t_{WLWH}	WRITE Enable Pulse Width	45		55		nS
t_{ELEH}	Chip Enable Low to Chip Enable High	50		60		nS
t_{WHAX}	WRITE Enable High to Address Transition	0		0		nS
t_{EHAX}	Chip Enable High to Address Transition	0		0		nS
t_{DVWH}	Input Valid to WRITE Enable High	25		30		nS
t_{DVEH}	Input Valid to Chip Enable High	25		30		nS
t_{WHDX}	WRITE Enable High to Input Transition	0		0		nS
t_{EHDX}	Chip Enable High to Input Transition	0		0		nS
$t_{WLQZ}^{(2,3)}$	WRITE Enable Low to Output High-Z		20		25	nS
t_{AVWH}	Address Valid to WRITE Enable High	55		65		nS
t_{AVEH}	Address Valid to Chip Enable High	55		65		nS
$t_{WHQX}^{(2,3)}$	WRITE Enable High to Output Transition	5		5		nS

Note :

1. Valid for Ambient Operating Temperature: TA = 0 to 70°C; VCC = 4.5 to 5.5V or 3.0 to 3.6V (except where noted).
2. CL = 5pF.
3. If /CE goes low simultaneously with /WE going low, the outputs remain in the high impedance state.

Data Retention Mode

With valid V_{CC} applied, the HMNR88D(V) operates as a conventional Byte-wide static RAM. Should the supply voltage decay, the RAM will automatically deselect, write protecting itself when V_{CC} falls between V_{PF D} (max), V_{PF D} (min) window. All outputs become high impedance and all inputs are treated as "Don't care."

Note : A power failure during a WRITE cycle may corrupt data at the current addressed location, but does not jeopardize the rest of the RAM's content. At voltages below V_{PF D} (min), the memory will be in a write protected state, provided the V_{CC} fall time is not less than t_F. The HMNR88D(V) may respond to transient noise spikes on V_{CC} that cross into the deselect window during the time the device is sampling V_{CC}. Therefore, decoupling of the power supply lines is recommended. When V_{CC} drops below V_{SO}, the control circuit switches power to the internal battery, preserving data and powering the clock. The internal energy source will maintain data in the HMNR88D(V) for an accumulated period of at least 10 years at room temperature. As system power rises above V_{SO}, the battery is disconnected, and the power supply is switched to external V_{CC}. Write protection continues until V_{CC} reaches V_{PF D} (min) plus t_{REC} (min). Normal RAM operation can resume t_{REC} after V_{CC} exceeds V_{PF D} (max).

Power Down/Up Mode AC Waveforms

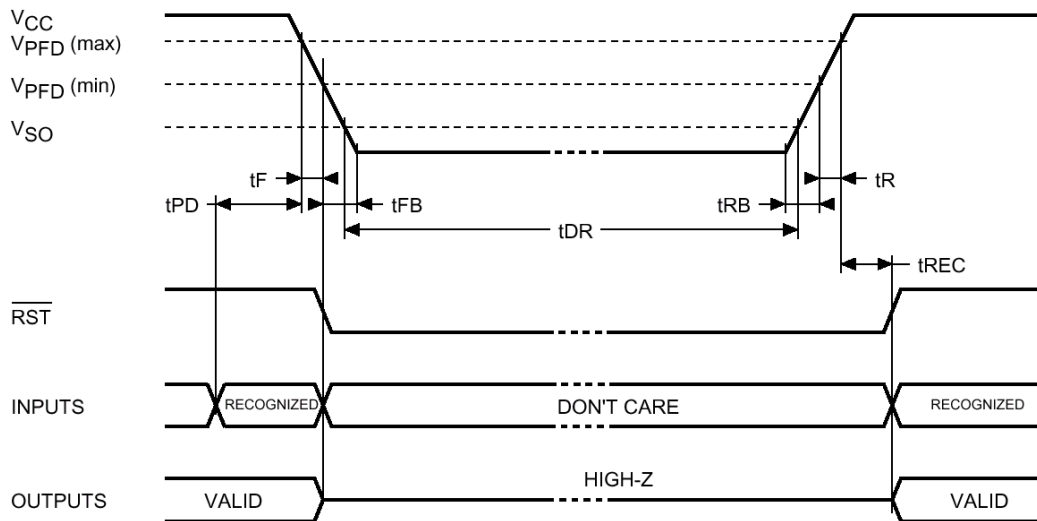

Power Down/Up AC Characteristics

Symbol	Parameter	Min	Max	Unit
$t_F^{(2)}$	$V_{PFD} (max)$ to $V_{PFD} (min)$ V_{CC} Fall Time	300		μS
$t_{FB}^{(3)}$	$V_{PFD} (min)$ to V_{SS} V_{CC} Fall Time	HMNR88D	10	μS
		HMNR88DV	150	μS
t_R	$V_{PFD} (min)$ to $V_{PFD} (max)$ V_{CC} Rise Time	10		μS
$t_{REC}^{(4)}$	$V_{PFD} (max)$ to RST High	40	200	μS
t_{RB}	V_{SS} to $V_{PFD} (min)$ V_{CC} Rise Time	5		μS

Note :

- Valid for Ambient Operating Temperature: $T_A = 0$ to $70^\circ C$; $V_{CC} = 4.5$ to $5.5V$ or 3.0 to $3.6V$ (except where noted).
- $V_{PFD} (max)$ to $V_{PFD} (min)$ fall time of less than t_F may result in deselection/write protection not occurring until $200\mu s$ after V_{CC} passes $V_{PFD} (min)$.
- $V_{PFD} (min)$ to V_{SS} fall time of less than t_{FB} may cause corruption of RAM data.

Power Down/Up Trip Points DC Characteristics

Symbol	Parameter ^(1,2)	Min	Typ	Max	Unit	
V_{PFD}	Power-fail Deselect Voltage	HMNR88D	4.2	4.35	4.5	V
		HMNR88DV	2.7	2.9	3.0	V
V_{SO}	Battery Back-up Switchover Voltage	HMNR88D		3.0		V
		HMNR88DV		$V_{PFD}-100mV$		V
$T_{DR}^{(3)}$	Expected Data Retention Time	10			YEARS	

Note:

- All voltages referenced to V_{SS} .
- Valid for Ambient Operating Temperature: $T_A = 0$ to $70^\circ C$; $V_{CC} = 4.5$ to $5.5V$ or 3.0 to $3.6V$ (except where noted).
- At $25^\circ C$.

Register Map

Address	Data								Funtion / Range BCD Format	
	D7	D6	D5	D4	D3	D2	D1	D0		
1FFFh	10Years				Year				Year	00-99
1FFEh	0	0	0	10M	Month				Month	01-12
1FFDh	0	0	10 Date		Date : Day of Month				Date	01-31
1FFCh	0	0	0	0	0	Day			Day	01-07
1FFBh	0	0	10 Hours		Hours(24 Hour Format)				Hours	00-23
1FFAh	0	10 Minutes			Minutes				Minutes	00-59
1FF9h	ST	10 Seconds			Seconds				Seconds	00-59
1FF8h	W	R	S	Calibration					Control	
1FF7h	0	0	0	0	0	0	0	0		
1FF6h	0	0	0	0	0	0	0	0		
1FF5h	0	0	0	0	0	0	0	0		
1FF4h	0	0	0	0	0	0	0	0		
1FF3h	0	0	0	0	0	0	0	0		
1FF2h	0	0	0	0	0	0	0	0		
1FF1h	1000 Years				100 Years				Century	00-99
1FF0h	0	0	0	BL	Z	Z	Z	Z	Flag	

Keys :

S = Sign Bit
 R = READ Bit
 W= WRITE Bit
 ST = Stop Bit

BL = Battery Low Flag(Read only)
 Z = '0' and are Read only
 0 = Must be set to '0'
 Y = '1' or '0'

CLOCK OPERATIONS

The HMNR88D(V) offers 16 internal registers which contain TIMEKEEPER, and Control data. These registers are memory locations which contain external (user accessible) and internal copies of the data. The external copies are independent of internal functions except that they are updated periodically by the simultaneous transfer of the incremented internal copy. TIMEKEEPER Registers store data in BCD. Control Registers store data in Binary Format.

Reading the Clock

Updates to the TIMEKEEPER registers should be halted before clock data is read to prevent reading data in transition. The TIMEKEEPER cells in the RAM array are only data registers and not the actual clock counters, so updating the registers can be halted without disturbing the clock itself. Updating is halted when a '1' is written to the READ Bit, D6 in the Control Register (1FF8h). As long as a '1' remains in that position, updating is halted. After a halt is issued, the registers reflect the count; that is, the day, date, and time that were current at the moment the halt command was is-sued. All of the TIMEKEEPER registers are updated simultaneously. A halt will not interrupt an update in progress. Updating occurs approximately 1 second after the READ Bit is reset to a '0.'

Setting the Clock

Bit D7 of the Control Register (1FF8h) is the WRITE Bit. Setting the WRITE Bit to a '1,' like the READ Bit, halts updates to the TIMEKEEPER registers. The user can then load them with the correct day, date, and time data in 24-hour BCD format. Resetting the WRITE Bit to a '0' then transfers the values of all time registers (1FFh-1FF9h, 1FF1h) to the actual TIMEKEEPER counters and allows normal operation to resume. After the WRITE Bit is reset, the next clock update will occur approximately one second later.

Note: Upon power-up following a power failure, both the WRITE Bit and the READ Bit will be reset to '0.'

Stopping and Starting the Oscillator

The oscillator may be stopped at any time. If the device is going to spend a significant amount of time on the shelf, the oscillator can be turned off to minimize current drain on the battery. The STOP Bit is located at Bit D7 within the Seconds Register (1FF9h). Setting it to a '1' stops the oscillator. When reset to a '0,' the HMNR88D(V) oscillator starts within one second.

Note : It is not necessary to set the WRITE Bit when setting or resetting the STOP Bit (ST).

Power-on Reset

The HMNR88D(V) continuously monitors VCC .When VCC falls to the power fail detect trip point, the /RST pulls low (open drain) and remains low on power-up for t_{REC} after VCC passes V_{PFD} (max). /RST is valid for all VCC conditions. The /RST pin is an open drain output and an appropriate resistor to VCC should be chosen to control rise time.

Calibrating the Clock

The HMNR88D(V) is driven by a quartz controlled oscillator with a nominal frequency of 32,768Hz. The devices are factory calibrated at 25°C and tested for accuracy. Clock accuracy will not exceed 35 ppm (parts per million) oscillator frequency error at 25°C, which equates to about ± 1.53 minutes per month. When the Calibration circuit is properly employed, accuracy improves to better than $\pm 1/2$ ppm at 25°C. The oscillation rate of crystals changes with temperature. The HMNR88D(V) design employs periodic counter correction. The calibration circuit adds or subtracts counts from the oscillator divider circuit at the divide by 256 stage. The number of times pulses are blanked (subtracted, negative calibration) or split (added, positive calibration) depends upon the value loaded into the five Calibration bits found in the Control Register.

Adding counts speeds the clock up, subtracting counts slows the clock down. The Calibration bits occupy the five lower order bits (D4-D0) in the Control Register 1FF8h. These bits can be set to represent any value between 0 and 31 in binary form. Bit D5 is a Sign bit; '1' indicates positive calibration, '0' indicates negative calibration. Calibration occurs within a 64 minute cycle. The first 62 minutes in the cycle may, once per minute, have one second either shortened by 128 or lengthened by 256 oscillator cycles. If a binary '1' is loaded into the register, only the first 2 minutes in the 64 minute cycle will be modified; if a binary 6 is loaded, the first 12 will be affected, and so on. Therefore, each calibration step has the effect of adding 512 or subtracting 256 oscillator cycles for every 125, 829, 120 actual oscillator cycles; that is, +4.068 or -2.034 ppm of adjustment per calibration step in the calibration register. Assuming that the oscillator is running at exactly 32,768Hz, each of the 31 increments in the Calibration byte would represent +10.7 or -5.35 seconds per month which corresponds to a total range of +5.5 or -2.75 minutes per month. One method for ascertaining how much calibration a given HMNR88D(V) may require involves setting the clock, letting it run for a month and comparing it to a known accurate reference and recording deviation over a fixed period of time. This allows the designer to give the end user the ability to calibrate the clock as the environment requires, even if the final product is packaged in a nonuser serviceable enclosure. The designer could provide a simple utility that accesses the Calibration bits.

Battery Low Warning

The HMNR88D(V) automatically performs battery voltage monitoring upon power-up and at factory-programmed time intervals of approximately 24 hours. The Battery Low (BL) Bit, Bit D4 of Flags Register 1FF0h, will be asserted if the battery voltage is found to be less than approximately 2.5V. The BL Bit will remain asserted until completion of battery replacement and subsequent battery low monitoring tests, either during the next power-up sequence or the next scheduled 24hour interval. If a battery low is generated during a power-up sequence, this indicates that the battery is below approximately 2.5V and may not be able to maintain data integrity in the SRAM. Data should be considered suspect and verified as correct. A fresh battery should be installed. If a battery low indication is generated during the 24-hour interval check, this indicates that the battery is near end of life. However, data is not compromised due to the fact that a nominal V_{CC} is supplied.

Power Supply Decoupling and Undershoot Protection

Note: I_{CC} transients, including those produced by output switching, can produce voltage fluctuations, resulting in spikes on the V_{CC} bus. These transients can be reduced if capacitors are used to store energy which stabilizes the V_{CC} bus. The energy stored in the bypass capacitors will be released as low going spikes are generated or energy will be absorbed when overshoots occur. A ceramic bypass capacitor value of 0.1 μ F is recommended in order to provide the needed filtering. In addition to transients that are caused by normal SRAM operation, power cycling can generate negative voltage spikes on V_{CC} that drive it to values below V_{SS} by as much as one volt. These negative spikes can cause data corruption in the SRAM while in battery backup mode. To

protect from these voltage spikes, ST recommends connecting a schottky diode from V_{CC} to V_{SS} (cathode connected to V_{CC} , anode to V_{SS}). (Schottky diode 1N5817 is recommended for through hole and MBR5120T3 is recommended for surface mount).

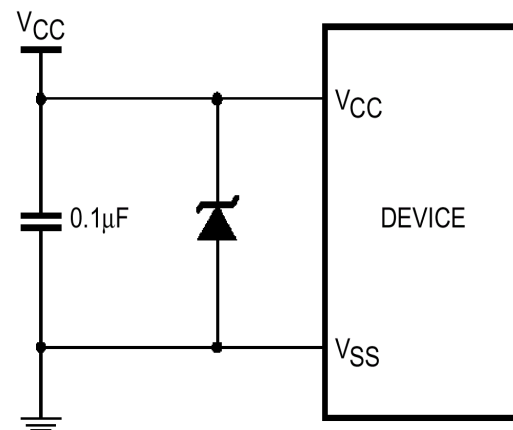

PACKAGE DIMENSION

Dimension	Min	Max
A	1.470	1.500
B	0.710	0.740
C	0.365	0.375
D	0.012	-
E	0.008	0.013
F	0.590	0.630
G	0.017	0.023
H	0.090	0.110
I	0.075	0.110
J	0.120	0.150

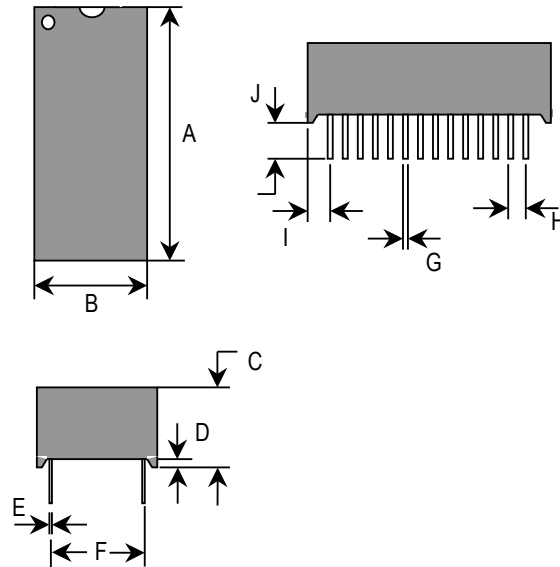

ORDERING INFORMATION

H M N R 88 D V - 70 I

