

DIGITAL COMPASS SOLUTION

Features

- 5° Heading Accuracy, 0.5° Resolution
- 2-axis Capability
- Small Size (19mm x 19mm x 4.5mm), Light Weight
- Advanced Hard Iron Calibration Routine for Stray Fields and Ferrous Objects
- 0° to 70°C Operating Temperature Range
- 2.6 to 5 volt DC Single Supply Operation

General Description

The Honeywell HMR3100 is a low cost, two-axis electronic compassing solution used to derive heading output. Honeywell's magnetoresistive sensors are utilized to provide the reliability and accuracy of these small, solid state compass designs. The HMR3100 communicates through binary data and ASCII characters at four selectable baud rates of 2400, 4800, 9600, or 19200. This compass solution is easily integrated into systems using a simple USART interface.

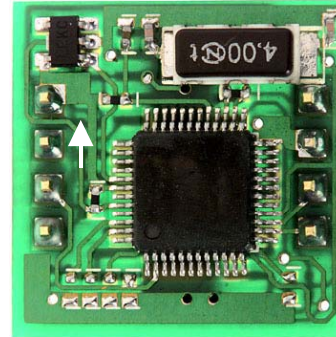

Top Side

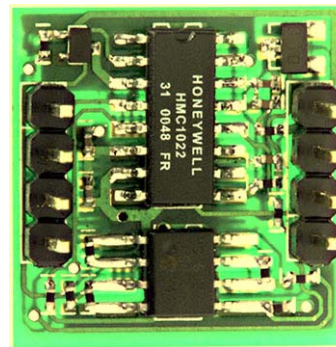

Bottom Side

APPLICATIONS

- Vehicle Compassing
- Hand-Held Electronics
- Telescope Positioning
- Navigation Systems

Block Diagram

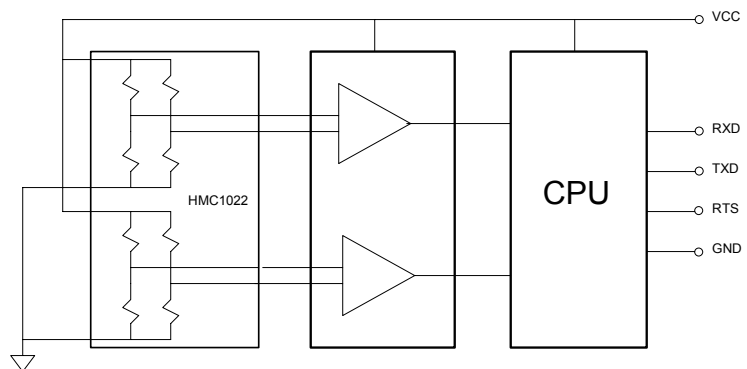

SPECIFICATIONS

Characteristics	Conditions	Min	Typ	Max	Units
-----------------	------------	-----	-----	-----	-------

Heading

Accuracy	Level		± 5		deg RMS
Resolution			0.5		deg
Repeatability			± 3		deg

Magnetic Field

Range	Maximum Magnetic Flux Density		± 2		gauss
Resolution			6		milli-gauss

Electrical

Input Voltage	Unregulated	2.6	3	5	volts DC
Current	Normal Mode (Average 1Hz Sampling)	0.1	0.2	0.5	mA
	Sleep Mode			1	µA
	Calibration	6.1	7.3	17.3	mA

Digital Interface

USART	USART 9600.N.8.1	2400	9600	19200	Baud
Update Rate	Continuous or Polled	-	2	20	Hz
Connector	8-Pin Wide DIP				-

Physical

Dimensions	Circuit Board Assembly		19 x 19 x 4.5		mm
Weight			1.5		grams

Environment

Temperature	Operating	0	-	+70	°C
	Storage	-40	-	+110	°C

Circuit Description

The HMR3100 Digital Compass Solution circuit board includes the basic magnetic sensors and electronics to provide a digital indication of heading. The HMR3100 has a Honeywell HMC1022 two-axis magnetic sensor on board. The HMR3100 allows users to derive compassing (heading) measurements when the board is in a reasonably horizontal (flat) position.

The HMR3100 circuit starts with the HMC1022 two-axis magnetic sensors providing X and Y axis magnetic sensing of the earth's field. These sensors are supplied power by a switching transistor to conserve power with battery operated products. The sensor output voltages are provided to a dual operational amplifier and then to analog to digital converters (ADC) onboard a microcontroller (µC) integrated circuit. The microcontroller integrated circuit periodically samples the amplified sensor voltages, performs the offset corrections, and computes the heading. This microcontroller also performs the external serial data interface and other housekeeping functions such as the calibration routine.

The power supply for the HMR3100 circuit board is to be about a +3 to +5 volt range allowing the user to provide a single lithium battery to logic level supply voltages. The power supply architecture is a single ground system for single ended supply sources (+ and ground return).

Note the “North Arrow” printed on the HMR3100 circuit board top side. This is the mechanical reference for product alignment purposes. When placed on the development kit’s RS-232 motherboard assembly, this arrow also points toward the 9-volt battery pin block on the motherboard (away from the RJ-11 jack).

Pin Configuration

Pin Number	Pin Name	Description
1	VCC	Power Supply Input
2	NC	No Connection
3	RTS	Ready To Send Input
4	NC	No Connection
5	TXD	Transmit Data Output
6	RXD	Receive Data Input
7	GND	Power and Signal Ground
8	NC	No Connection

The HMR3100 board is 0.77” on each side with eight pins in groups of four spaced at 0.6” apart in wide-DIP format. Seated height is approximately 0.275”. See Figure 1 for further mechanical details.

USART Communication Protocol

HMR3100 module communicates through binary data and ASCII characters at four selectable baud rates of 2400, 4800, 9600, or 19200. The default data bit format is USART 9600.N.8.1. The baud rate selection is determined by the position of jumpers J1 and J3. These jumpers are zero ohm SMT resistors (jumpers) and are normally high (logic 1) when removed, and grounded (logic 0) when in place. At 2400 baud, no jumpers are present for a 1,1 logic presentation. At 4800 baud J3 is present for a 1,0 logic presentation. The factory default setting of 9600 baud is created by a jumper present on J1 for a 0,1 logic presentation. With J1 and J3 jumpers present for a 0,0 logic presentation, the compass module works at 19200 baud. See Figure 1 for jumper locations. Jumper J2 is for factory testing, and J4 is for Y-axis inversion should the end-item mount of the HMR3100 module be upside down (pins up).

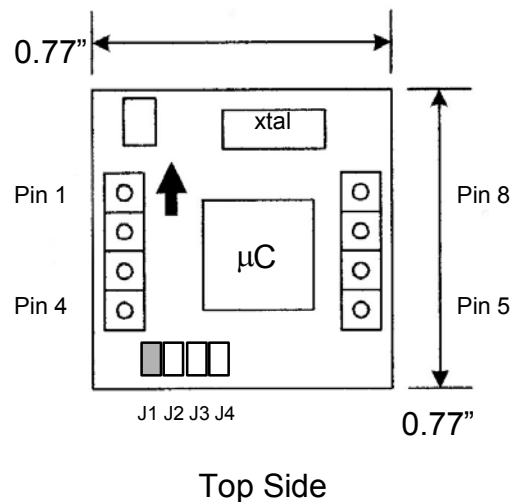

Figure 1
HMR3100 Pinout

The HMR3100 sends data via the TXD line (Pin 5) in standard serial bus form at logic levels, but uses the RTS (Pin 3) and RXD (Pin 6) to select the three active modes of operation. Normally RTS and RXD input lines are left high until data or hard-iron calibration is needed from the HMR3100. The RXD line is left high unless a calibration is requested. The RTS line will be either be pulsed low or held low to initiate an active mode. Otherwise a low-power sleep mode is the default state. The RXD and RTS data inputs are passively pulled high via the microcontroller if left open.

Normal Mode

When the host processor (external to the HMR3100), sends a RTS low pulse to the RTS pin, the HMR3100 will send status/heading data via the TXD pin. The host shall hold the RXD pin high during this mode. The RTS shall be held high when not pulsed. The HMR3100 will return to sleep mode when RTS is left high after the three-byte status/heading data packet is sent. Up to 20 heading queries per second can be accomplished given fast enough baud rates. A caution is advised that average current draw is proportional to supply voltage and amount of queries handled. At the 20 Hz rate, 1 to 5 milliamperes of current is consumed with lesser query rates taking advantage of the less than one-microampere sleep mode current draw between queries. Figure 2 shows the normal mode timing diagram.

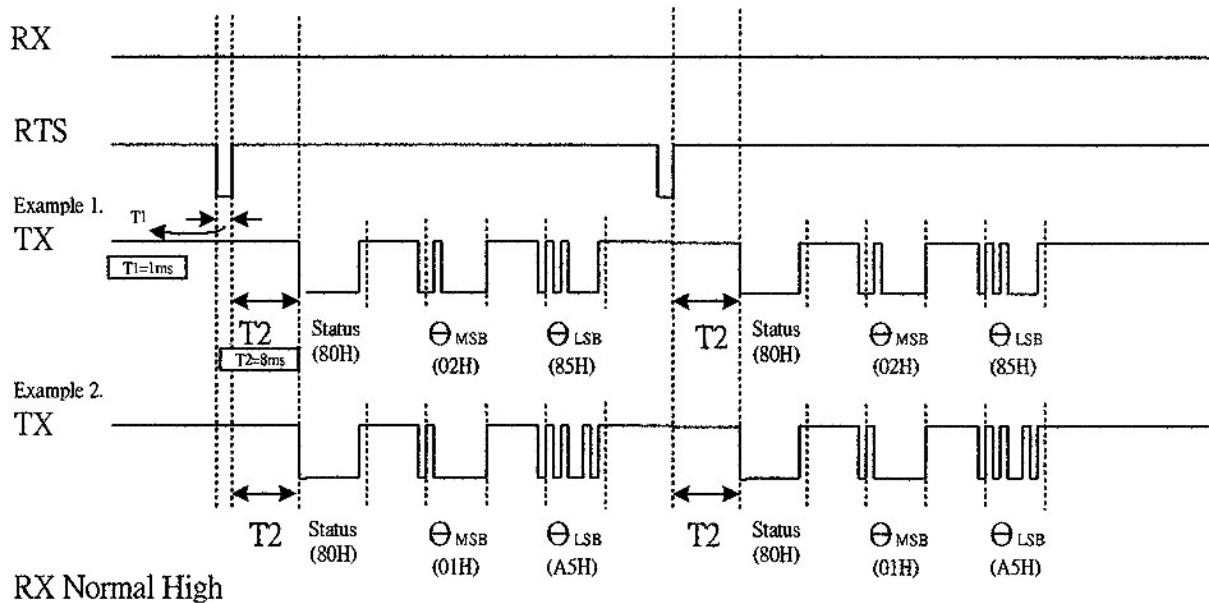

Figure 2
Normal Mode Timing Diagram

Continuous Mode

When the host processor (external to the HMR3100), holds the RTS input low, the HMR3100 will continuously send heading data via the TXD pin. The host shall hold the RXD pin high during this mode. The HMR3100 shall output the three-byte status/heading data packet at about a 2Hz rate. The HMR3100 will return to sleep mode when RTS is returned high. Figure 3 shows the continuous mode timing diagram.

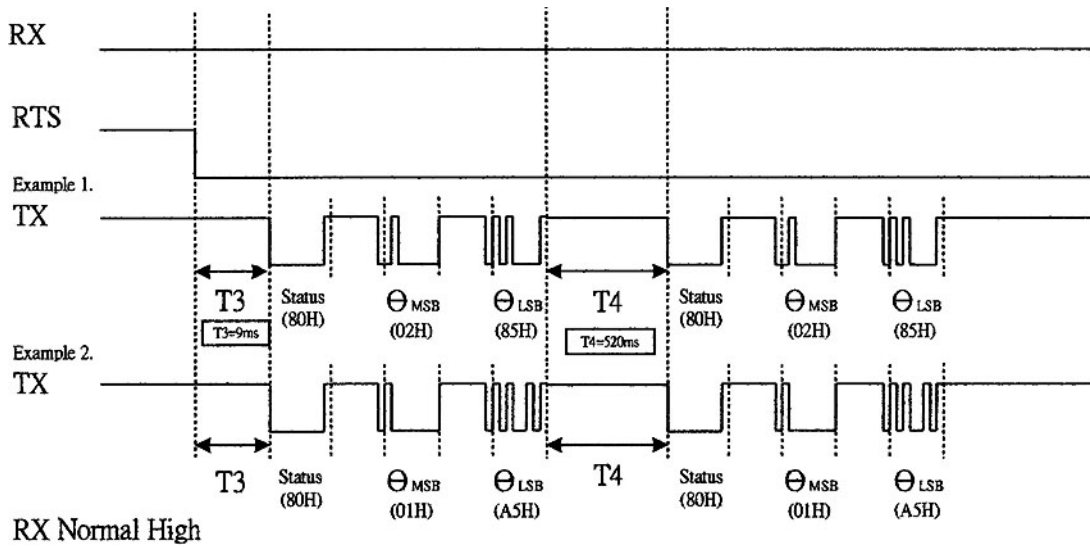

Figure 3
Continuous Mode Timing Diagram

Calibration Mode

When the host processor pulses low the RTS pin, and sends the RXD pin to a low logic level, the HMR3100 is in hard-iron calibration mode. This calibration is only for nearby magnetized metals (hard-iron) that are fixed in position with the HMR3100. At a moderate rate (5 seconds or more per rotation), rotate the HMR3100/host assembly two complete circles (on a flat, non-magnetic surface if possible) to allow the HMR3100 to take measurements for compass calibration. At the completion of the rotations, return the RXD to a high logic level. The HMR3100 will return to sleep mode until another active mode has been initiated. Upon initiation of the calibration mode, the microcontroller shall output an ASCII STA (53 54 41 hex) indicating a start of calibration and then an ASCII RDY (52 44 59 hex) at the completion of the rotations and the RXD line returned high. Figure 4 shows the calibration mode timing diagram.

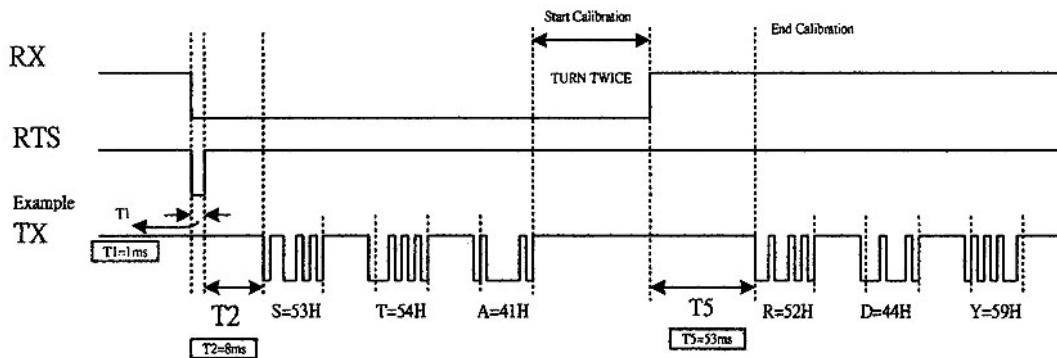

Figure 4
Calibration Mode Timing Diagram

Data Description

The HMR3100's onboard microcontroller sends a three byte status/heading data packet reply as the RTS line is brought low. The data is normally formatted in binary with the first byte being either 80(hex) or 81(hex).

If that first byte LSbit is flagged high (81 hex), it means magnetic distortion maybe present and a hard-iron calibration should be performed. Many end users may choose to ignore this indication in portable applications.

The remaining two bytes are the heading (in degrees) in MSB to LSB format. There is some data interpretation needed to derive the heading. For example, the 80 02 85 (hex) Byte pattern correlates to 322.5 degrees.

This is done by taking the MSB hex value, converting it to decimal (base ten) representation (e.g. 02 decimal) and multiplying it by 256. Then the LSB is decimalized (e.g. 85(hex) to 133(decimal)) and added to the 512(decimal) MSB. The total (512+133=645) is then divided by two to arrive at a 322.5 degree heading. This data format permits the 0.5° resolution in two bytes by doing the binary to decimal conversion and division by two.

Development Kit

The HMR3100 Development Kit includes additional hardware and Windows demo program software to form a development kit for electronic compassing. This kit includes the appropriate HMR3100 Printed Circuit Board (PCB) module soldered to an intermediate circuit board using a 0.8" spacing pin arrangement. The intermediate board assembly plugs into an RS-232 motherboard with a serial port connector. In addition, a four-foot serial port cable (RJ-11 to D-9F), nine-volt battery clip, demo program software, and user's guide is included. The RS-232 motherboard incorporates a 5-volt regulator integrated circuit to provide the necessary voltages to the onboard RS-232 converter integrated circuit and the HMR3100 daughter-board. A nine-volt battery clip is included, but other DC input voltages between 7 and 15 volts may be used. Supply currents are nominally around 8mA plus the HMR3100 current draw.

The RS-232 motherboard also contains a six-contact modular jack (RJ-11) for a compact RS-232 interface to a personal computer serial port. Ground, RTS, RXD, and TXD data lines are brought out to the jack with two contacts left open. The demo software stimulates the RTS and RXD lines and reads the data from the TXD line for graphical display on the host computer. No other support software is available. Figure 5 shows the kit board assemblies.

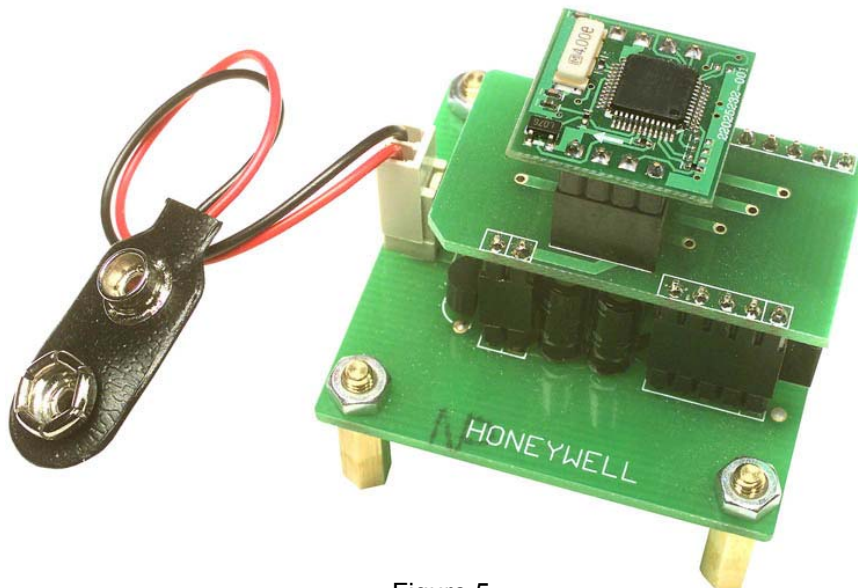

Figure 5
HMR3100 Kit Hardware

Ordering Information

Ordering Number	Product
HMR3100 HMR3100-Demo-232	PCB Module Only PCB Module with Development Kit

Honeywell reserves the right to make changes to improve reliability, function or design. Honeywell does not assume any liability arising out of the application or use of any product or circuit described herein; neither does it convey any license under its patent rights nor the rights of others.

900268 02-04 Rev. A