HN27C256HG Series

32768-word × 8-bit CMOS UV Erasable and Programmable
ROM

HITACHI

ADE-203-
Maintenance only
Rev. 0.0
Dec. 1, 1995

Description

The Hitachi HN27C256HG is a 256-kbit ultraviolet erasable and electrically programmable ROM, featuring sub-100-ns access times. The HN27C256HG realizes access time of 70 ns and 85 ns, employing the advanced fine process and high speed circuitry technique. The timing conditions such as access time or output hold time are designed as same as our byte-wide SRAMs', allowing to use with SRAMs on the same memory board by the same read timings. So its board design in 16-bit microprocessor systems is easy. Also, the HN27C256HG realizes faster programming time than our conventional 256-kbit EPROM by Hitachi's Fast High-Reliability Programming Algorithm. Pin arrangement, pin configuration and programming voltage are compatible with our 256-kbit EPROM series, therefore existing programmers can be used with the HN27C256HG.

Features

- High speed: Access time 70/85 ns (max)
- Low power dissipation
Active mode: 30 mW (typ) (f = 1 MHz)
- High reliability and fast programming
Programming voltage: +12.5 V DC
Fast High-Reliability Programming Algorithm available
- Device identifier mode
Manufacturer code and device code

Ordering Information

Type No.	Access Time	Package
HN27C256HG-70	70 ns	600-mil 28-pin cerdip (DG-28)
HN27C256HG-85	85 ns	

Note: This device is not available for new application.

HN27C256HG Series

Pin Arrangement

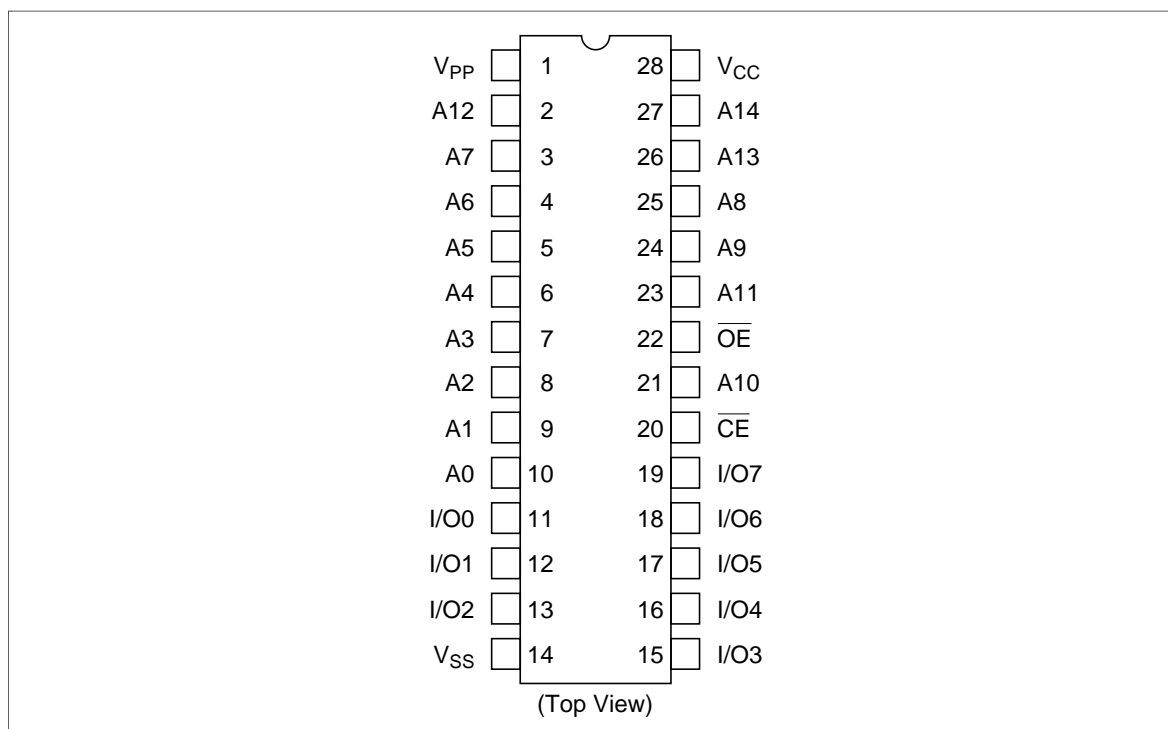

Pin Description

Pin Name	Function
A0 – A14	Address
I/O0 – I/O7	Input/output
\overline{CE}	Chip enable
\overline{OE}	Output enable
V_{CC}	Power supply
V_{PP}	Programming power supply
V_{SS}	Ground

Block Diagram

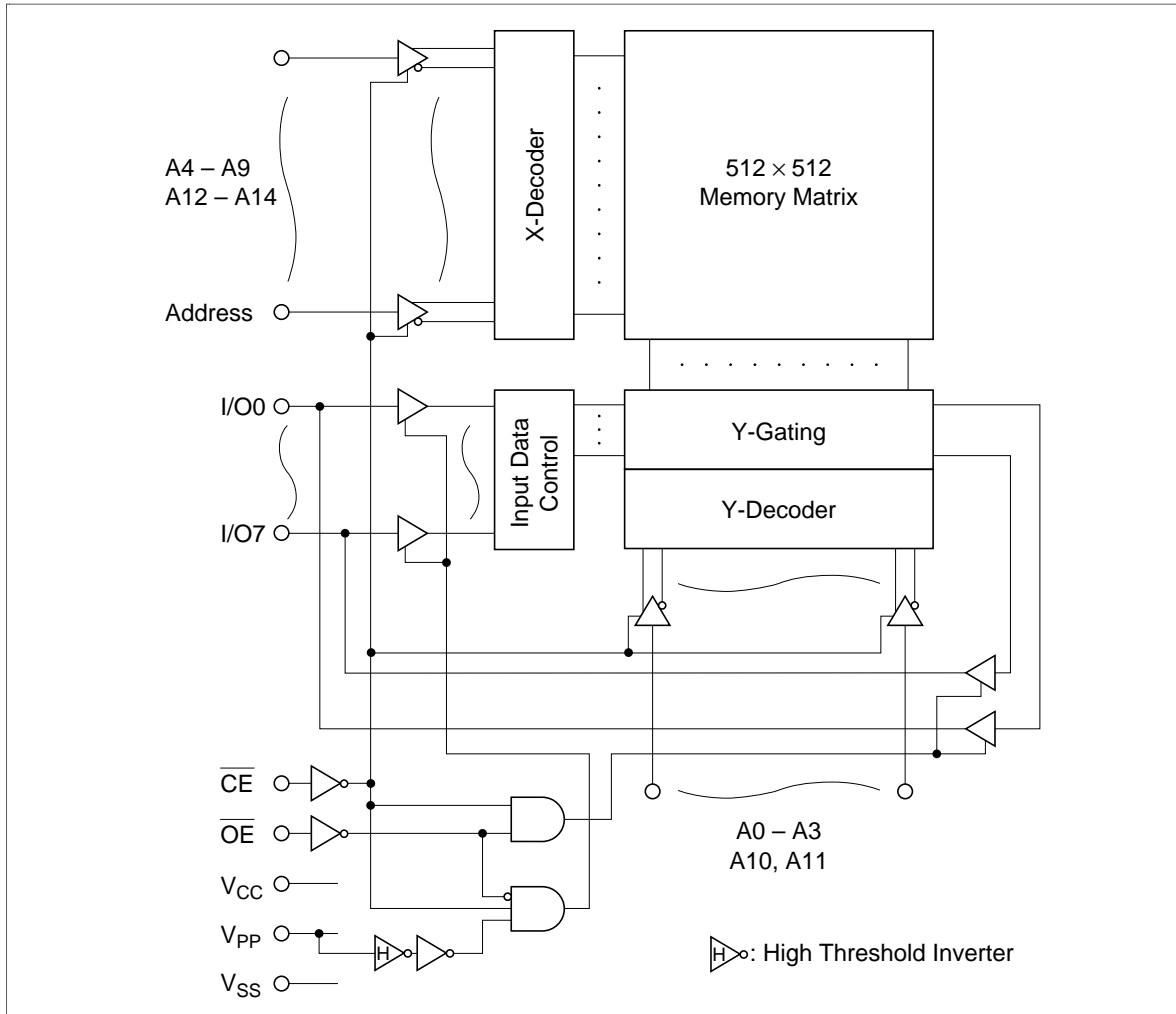

HN27C256HG Series

Mode Selection

Mode	$\overline{\text{CE}}$ (20)	$\overline{\text{OE}}$ (22)	A9 (24)	V_{PP} (1)	V_{CC} (28)	I/O (11 – 13, 15 – 19)
Read	V_{IL}	V_{IL}	X	V_{CC}	V_{CC}	Dout
Output disable	V_{IL}	V_{IH}	X	V_{CC}	V_{CC}	High-Z
Standby	V_{IH}	X	X	V_{CC}	V_{CC}	High-Z
Program	V_{IL}	V_{IH}	X	V_{PP}	V_{CC}	Din
Program verify	V_{IH}	V_{IL}	X	V_{PP}	V_{CC}	Dout
Optional verify	V_{IL}	V_{IL}	X	V_{PP}	V_{CC}	Dout
Program inhibit	V_{IH}	V_{IH}	X	V_{PP}	V_{CC}	High-Z
Identifier	V_{IL}	V_{IL}	V_{H}^2	V_{CC}	V_{CC}	Code

Notes: 1. X : Don't care.
2. V_{H} : 12.0 V \pm 0.5 V.

Absolute Maximum Ratings

Parameter	Symbol	Value	Unit
All input and output voltage ^{*1}	$V_{\text{in}}, V_{\text{out}}$	-0.6 ^{*2} to +7.0	V
A9 input voltage ^{*1}	V_{ID}	-0.6 ^{*2} to +13.5	V
V_{PP} voltage ^{*1}	V_{PP}	-0.6 to +13.5	V
V_{CC} voltage ^{*1}	V_{CC}	-0.6 to +7.0	V
Operating temperature range	T_{opr}	0 to +70	°C
Storage temperature range	T_{stg}	-65 to +125	°C
Storage temperature range under bias	T_{bias}	-10 to +80	°C

Notes: 1. Relative to V_{SS} .
2. $V_{\text{in}}, V_{\text{out}}, V_{\text{ID}}$ min = -1.0 V for pulse width \leq 50 ns.

Capacitance ($T_{\text{a}} = 25^{\circ}\text{C}$, $f = 1 \text{ MHz}$)

Parameter	Symbol	Min	Typ	Max	Unit	Test Conditions
Input capacitance	C_{in}	—	4	8	pF	$V_{\text{in}} = 0 \text{ V}$
Output capacitance	C_{out}	—	8	12	pF	$V_{\text{out}} = 0 \text{ V}$

Read Operation
DC Characteristics ($T_a = 0$ to $+70^\circ\text{C}$, $V_{CC} = 5\text{ V} \pm 10\%$, $V_{PP} = V_{CC}$)

Parameter	Symbol	Min	Typ	Max	Unit	Test Conditions
Input leakage current	I_{LI}	—	—	2	μA	$V_{in} = 0\text{ V to } V_{CC}$
Output leakage current	I_{LO}	—	—	2	μA	$V_{out} = 0\text{ V to } V_{CC}$
V_{PP} current	I_{PP1}	—	1	100	μA	$V_{PP} = 5.5\text{ V}$
Standby V_{CC} current	I_{SB}	—	—	15	mA	$\overline{CE} = V_{IH}$
Operating V_{CC} current	I_{CC1}	—	—	30	mA	$\overline{CE} = V_{IL}$, $I_{out} = 0\text{ mA}$
	I_{CC2}	—	—	50	mA	$f = 15\text{ MHz}$, $I_{out} = 0\text{ mA}$
	I_{CC3}	—	5	15	mA	$f = 1\text{ MHz}$, $I_{out} = 0\text{ mA}$
Input low voltage ³	V_{IL}	-0.3^{*1}	—	0.8	V	
Input high voltage ³	V_{IH}	2.2	—	$V_{CC} + 1.0^{*2}$	V	
Output low voltage	V_{OL}	—	—	0.45	V	$I_{OL} = 2.1\text{ mA}$
Output high voltage	V_{OH1}	2.4	—	—	V	$I_{OH} = -1.0\text{ mA}$
	V_{OH2}	$V_{CC} - 0.7$	—	—	V	$I_{OH} = -100\ \mu\text{A}$

- Notes: 1. V_{IL} min = -1.0 V for pulse width $\leq 50\text{ ns}$.
 2. V_{IH} max = $V_{CC} + 1.5\text{ V}$ for pulse width $\leq 20\text{ ns}$.
 If V_{IH} is over the specified maximum value, read operation cannot be guaranteed.
 3. Only defined for DC function test. V_{IL} max = 0.45 V , V_{IH} min = 2.4 V for AC function test.

HN27C256HG Series

AC Characteristics ($T_a = 0$ to $+70^\circ\text{C}$, $V_{CC} = 5\text{ V} \pm 10\%$, $V_{PP} = V_{CC}$)

Test Conditions

- Input pulse levels: 0.45 V to 2.4 V
- Input rise and fall time: ≤ 10 ns
- Output load: 1TTL gate + 100 pF
- Reference levels for measuring timing: Inputs; 1.5 V
Outputs; 1.5 V

		HN27C256HG					
		-70		-85			
Parameter	Symbol	Min	Max	Min	Max	Unit	Test Conditions
Address to output delay	t_{ACC}	—	70	—	85	ns	$\overline{CE} = \overline{OE} = V_{IL}$
\overline{CE} to output delay	t_{CE}	—	70	—	85	ns	$\overline{OE} = V_{IL}$
\overline{OE} to output delay	t_{OE}	—	40	—	45	ns	$\overline{CE} = V_{IL}$
\overline{OE} high to output float	t_{DF}	0	30	0	30	ns	$\overline{CE} = V_{IL}$
Address to output hold	t_{OH}	5	—	5	—	ns	$\overline{CE} = \overline{OE} = V_{IL}$

Note: t_{DF} is defined as the time at which the output achieves the open circuit condition and data is no longer driven.

Read Timing Waveform

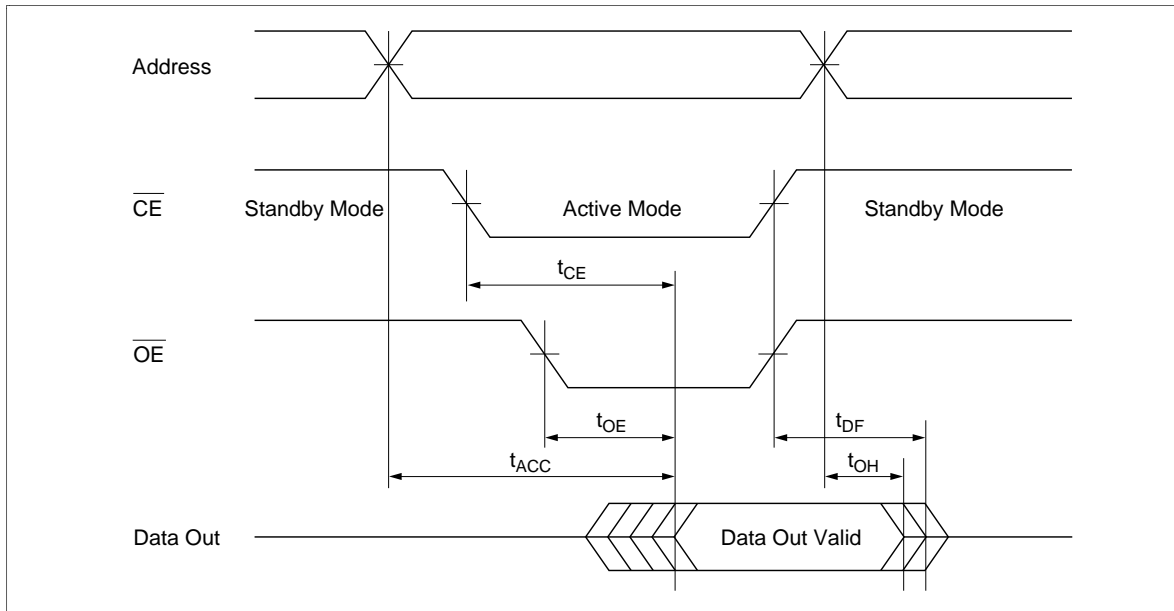

Fast High-Reliability Programming

This device can be applied the Fast High-Reliability Programming Algorithm shown in following flowchart. This algorithm offers both faster programming time and high reliability data retention. A theoretical programming time (except blank checking and verifying time) is one-tenth of conventional high performance programming algorithm's. Regarding the model and software version of the programmers available this algorithm, please contact programmer maker.

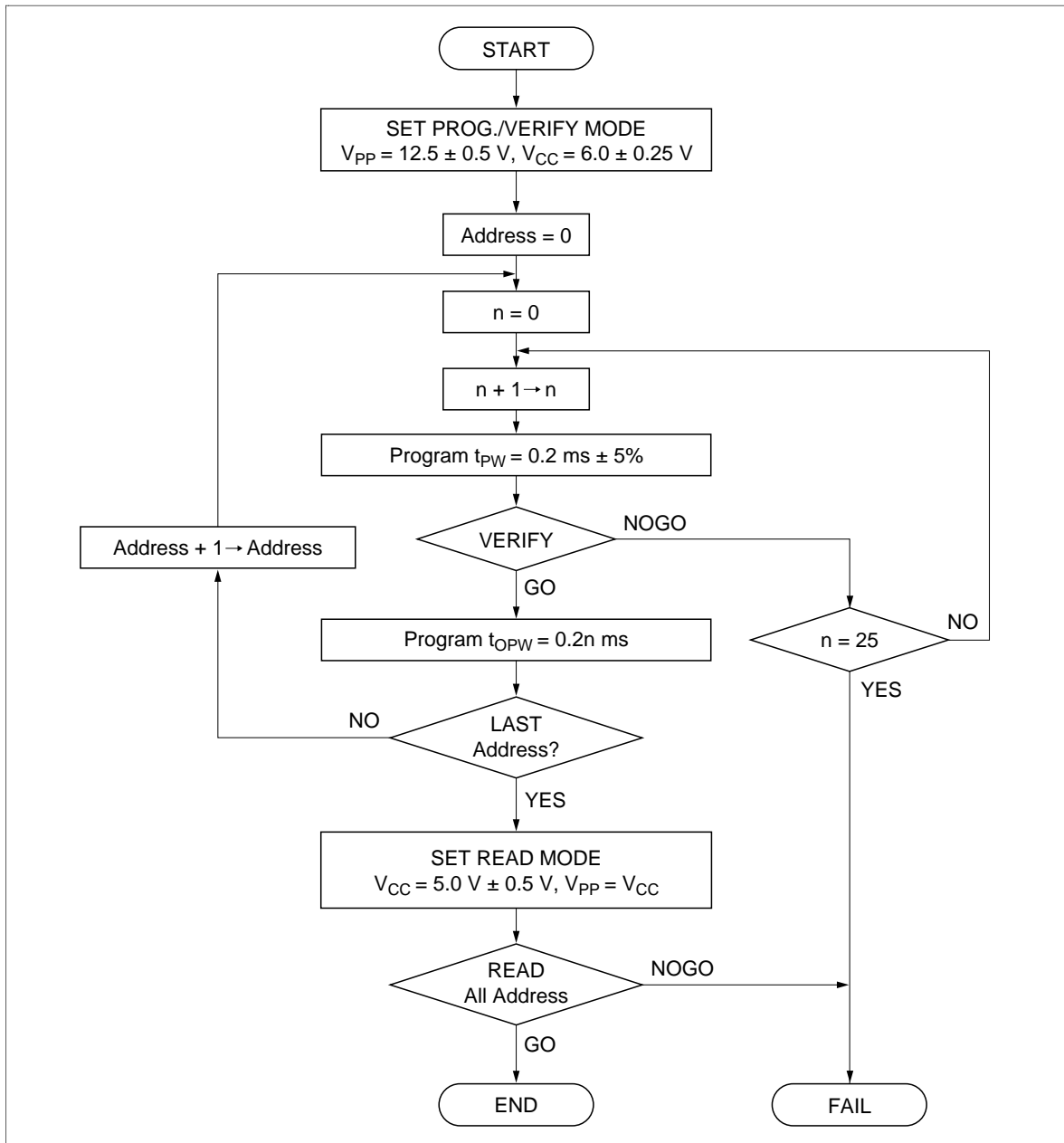

HN27C256HG Series

DC Characteristics ($T_a = 25^\circ\text{C} \pm 5^\circ\text{C}$, $V_{CC} = 6\text{ V} \pm 0.25\text{ V}$, $V_{PP} = 12.5\text{ V} \pm 0.5\text{ V}$)

Parameter	Symbol	Min	Typ	Max	Unit	Test Conditions
Input leakage current	I_{LI}	—	—	2	μA	$V_{in} = 0\text{ V to } V_{CC}$
V_{PP} supply current	I_{PP}	—	—	30	mA	$\overline{CE} = V_{IL}$
Operating V_{CC} current	I_{CC}	—	—	30	mA	
Input low level	V_{IL}	-0.1^{*5}	—	0.8	V	
Input high level	V_{IH}	2.2	—	$V_{CC} + 0.5^{*6}$	V	
Output low voltage during verify	V_{OL}	—	—	0.45	V	$I_{OL} = 2.1\text{ mA}$
Output high voltage during verify	V_{OH}	2.4	—	—	V	$I_{OH} = -400\ \mu\text{A}$

- Notes:
1. V_{CC} must be applied simultaneously or before V_{PP} and removed simultaneously or after V_{PP} .
 2. V_{PP} must not exceed 13.5 V including overshoot.
 3. An influence may be had upon device reliability if the device is installed or removed while $V_{PP} = 12.5\text{ V}$.
 4. Do not alter V_{PP} either V_{IL} to 12.5 V or 12.5 V to V_{IL} when $\overline{CE} = \text{Low}$.
 5. V_{IL} min = -0.6 V for pulse width $\leq 20\text{ ns}$.
 6. If V_{IH} is over the specified maximum value, programming operation cannot be guaranteed.

HN27C256HG Series

AC Characteristics ($T_a = 25^\circ\text{C} \pm 5^\circ\text{C}$, $V_{CC} = 6\text{ V} \pm 0.25\text{ V}$, $V_{PP} = 12.5\text{ V} \pm 0.5\text{ V}$)

Test Conditions

- Input pulse levels: 0.45 V to 2.4 V
- Input rise and fall time: $\leq 20\text{ ns}$
- Reference levels for measuring timing: Inputs; 0.8 V and 2.0 V
Outputs; 0.8 V and 2.0 V

Parameter	Symbol	Min	Typ	Max	Unit	Test Conditions
Address setup time	t_{AS}	2	—	—	μs	
\overline{OE} setup time	t_{OES}	2	—	—	μs	
Data setup time	t_{DS}	2	—	—	μs	
Address hold time	t_{AH}	0	—	—	μs	
Data hold time	t_{DH}	2	—	—	μs	
V_{PP} setup time	t_{VPS}	2	—	—	μs	
V_{CC} setup time	t_{VCS}	2	—	—	μs	
\overline{CE} initial programming pulse width	t_{PW}	0.19	0.20	0.21	ms	
\overline{CE} over programming pulse width	t_{OPW}^{*1}	0.19	—	5.25	ms	
Data valid from \overline{OE}	t_{OE}	0	—	150	ns	
\overline{OE} to output float delay	t_{DF}^{*2}	—	—	130	ns	

Notes: 1. Refer to the Fast High-Reliability Programming Flowchart for t_{OPW} .

2. t_{DF} is defined as the time at which the output achieves the open circuit condition and data is no longer driven.

HN27C256HG Series

Fast High-Reliability Programming Timing Waveform

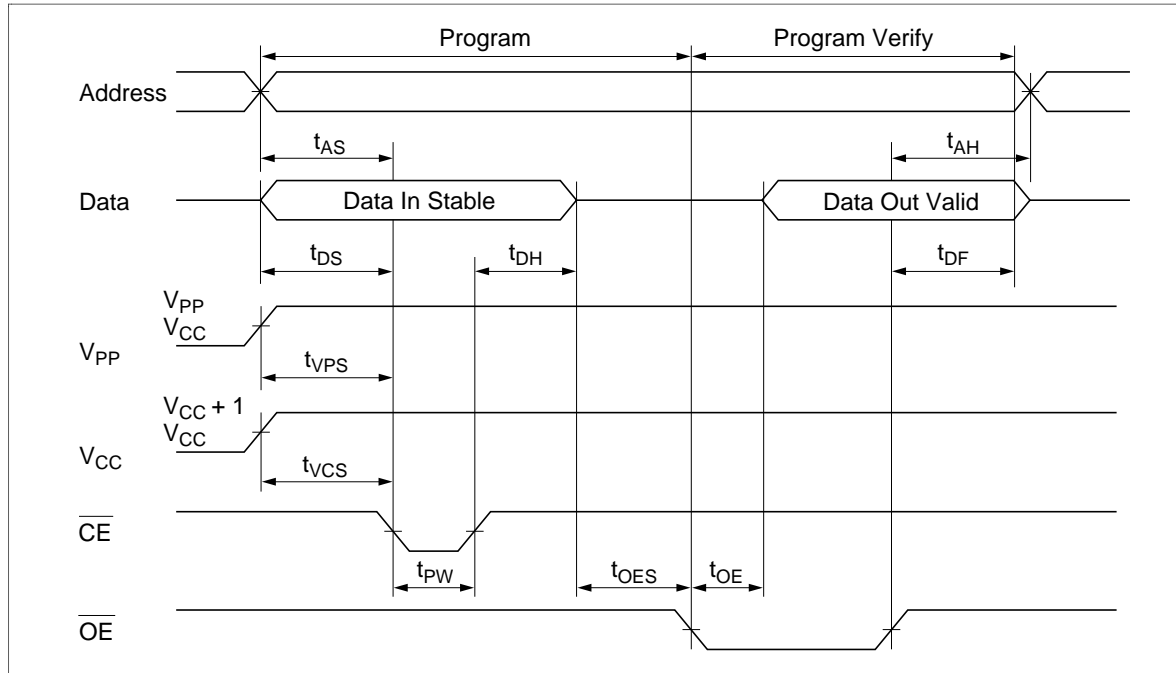

High Performance Programming

This device can be applied the high performance programming algorithm shown in following flowchart. This algorithm is as same as our 256-kbit EPROM series, so existing programmers can be used with this device. This algorithm allows to obtain faster programming time without any voltage stress to the device nor deterioration in reliability of programmed data.

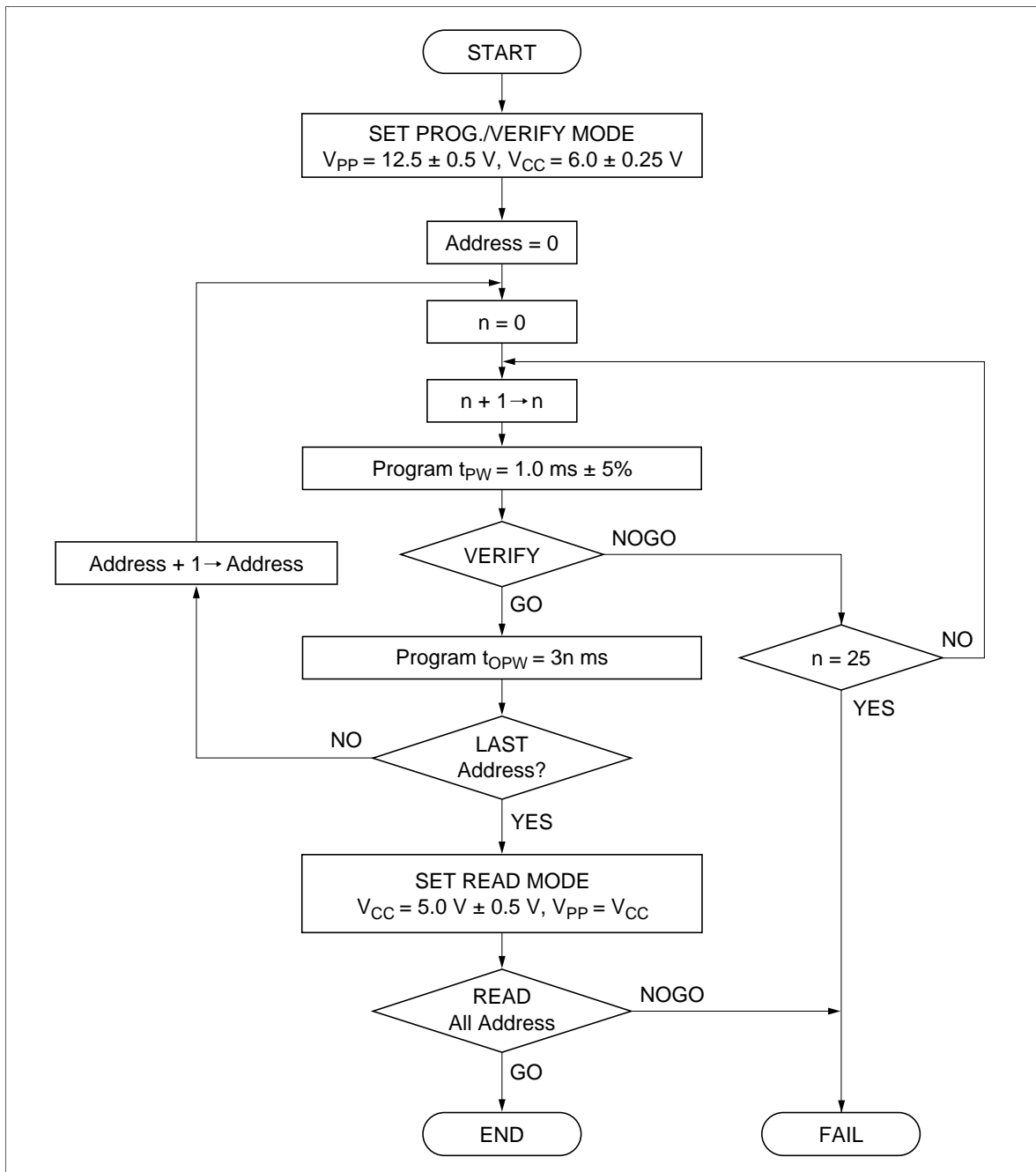

HN27C256HG Series

DC Characteristics ($T_a = 25^\circ\text{C} \pm 5^\circ\text{C}$, $V_{CC} = 6\text{ V} \pm 0.25\text{ V}$, $V_{PP} = 12.5\text{ V} \pm 0.5\text{ V}$)

Parameter	Symbol	Min	Typ	Max	Unit	Test Conditions
Input leakage current	I_{LI}	—	—	2	μA	$V_{in} = 0\text{ V to } V_{CC}$
V_{PP} supply current	I_{PP}	—	—	30	mA	$\overline{CE} = V_{IL}$
Operating V_{CC} current	I_{CC}	—	—	30	mA	
Input low level	V_{IL}	-0.1^{*5}	—	0.8	V	
Input high level	V_{IH}	2.2	—	$V_{CC} + 0.5^{*6}$	V	
Output low voltage during verify	V_{OL}	—	—	0.45	V	$I_{OL} = 2.1\text{ mA}$
Output high voltage during verify	V_{OH}	2.4	—	—	V	$I_{OH} = -400\ \mu\text{A}$

- Notes:
- V_{CC} must be applied simultaneously or before V_{PP} and removed simultaneously or after V_{PP} .
 - V_{PP} must not exceed 13.5 V including overshoot.
 - An influence may be had upon device reliability if the device is installed or removed while $V_{PP} = 12.5\text{ V}$.
 - Do not alter V_{PP} either V_{IL} to 12.5 V or 12.5 V to V_{IL} when $\overline{CE} = \text{Low}$.
 - V_{IL} min = -0.6 V for pulse width $\leq 20\text{ ns}$.
 - If V_{IH} is over the specified maximum value, programming operation cannot be guaranteed.

HN27C256HG Series

AC Characteristics ($T_a = 25^\circ\text{C} \pm 5^\circ\text{C}$, $V_{CC} = 6\text{ V} \pm 0.25\text{ V}$, $V_{PP} = 12.5\text{ V} \pm 0.5\text{ V}$)

Test Conditions

- Input pulse levels: 0.45 V to 2.4 V
- Input rise and fall time: $\leq 20\text{ ns}$
- Reference levels for measuring timing: Inputs; 1.5 V
Outputs; 1.5 V

Parameter	Symbol	Min	Typ	Max	Unit	Test Conditions
Address setup time	t_{AS}	2	—	—	μs	
\overline{OE} setup time	t_{OES}	2	—	—	μs	
Data setup time	t_{DS}	2	—	—	μs	
Address hold time	t_{AH}	0	—	—	μs	
Data hold time	t_{DH}	2	—	—	μs	
V_{PP} setup time	t_{VPS}	2	—	—	μs	
V_{CC} setup time	t_{VCS}	2	—	—	μs	
\overline{CE} initial programming pulse width	t_{PW}	0.95	1.0	1.05	ms	
\overline{CE} over programming pulse width	t_{OPW}^{*1}	2.85	—	78.75	ms	
Data valid from \overline{OE}	t_{OE}	0	—	150	ns	
\overline{OE} to output float delay	t_{DF}^{*2}	—	—	130	ns	

Notes: 1. Refer to the high performance programming flowchart for t_{OPW} .

2. t_{DF} is defined as the time at which the output achieves the open circuit condition and data is no longer driven.

HN27C256HG Series

High Performance Programming Timing Waveform

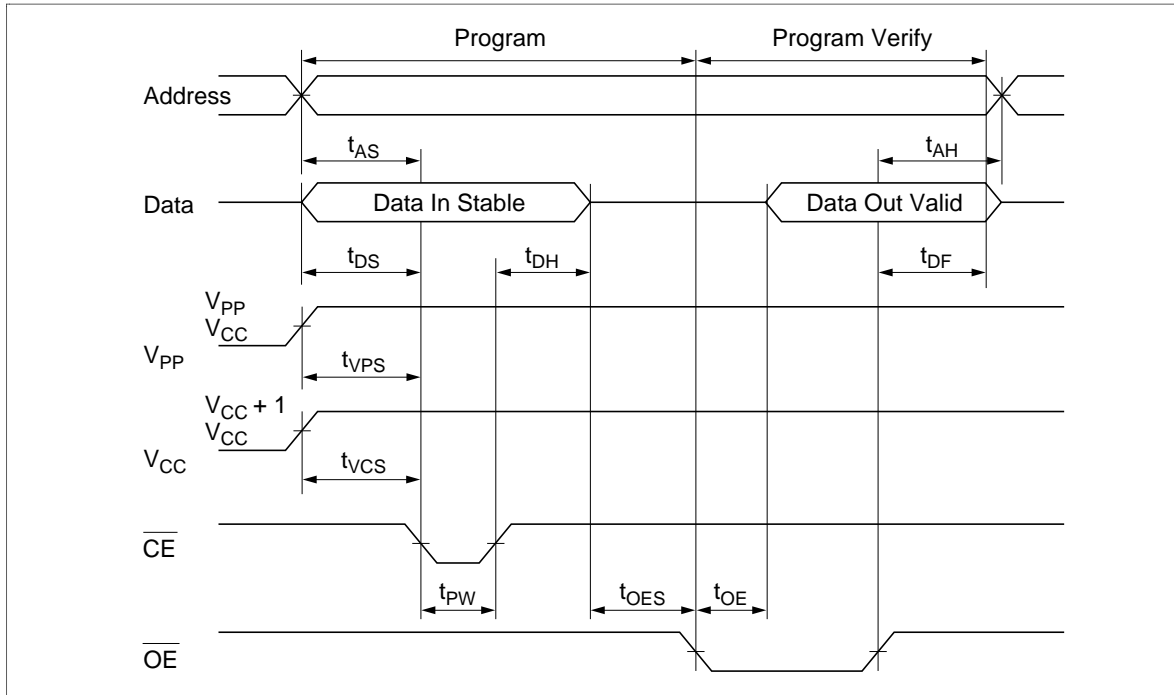

Erase

Erase of HN27C256HG is performed by exposure to ultraviolet light of 2537 Å and all the output data are changed to „1“ after this erasure procedure. The minimum integrated dose (i.e. UV intensity × exposure time) for erasure is 15 W•sec/cm².

Mode Description

Device Identifier Mode

Programming condition of EPROM is various according to EPROM manufacturers and device types. It may cause miss operation. To countermeasure it, some EPROMs provide maker identifier code. Users can write EPROM by reading out write condition coded before shipped. Some commercial programmers can set write condition by recognizing this code. This function enables effective program. Regarding commercial programmers that can recognize this device's identifier code, please contact programmer maker.

HN27C256HG Series Identifier Code

Identifier	A0 (10)	I/O7 (19)	I/O6 (18)	I/O5 (17)	I/O4 (16)	I/O3 (15)	I/O2 (13)	I/O1 (12)	I/O0 (11)	Hex Data
Manufacturer code	V _{IL}	0	0	0	0	0	1	1	1	07
Device code	V _{IH}	0	0	1	1	0	0	0	1	31

Notes: 1. A9 = 12.0 V ± 0.5 V.

2. A1 – A8, A10 – A14, \overline{CE} , \overline{OE} = V_{IL}.

Electric Characteristics Curves

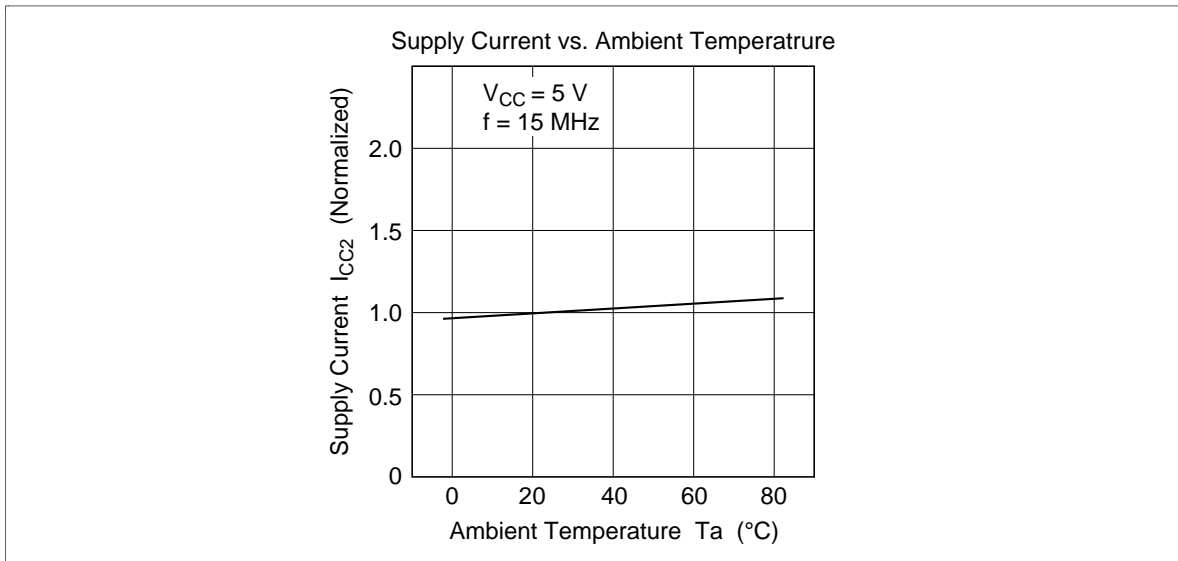
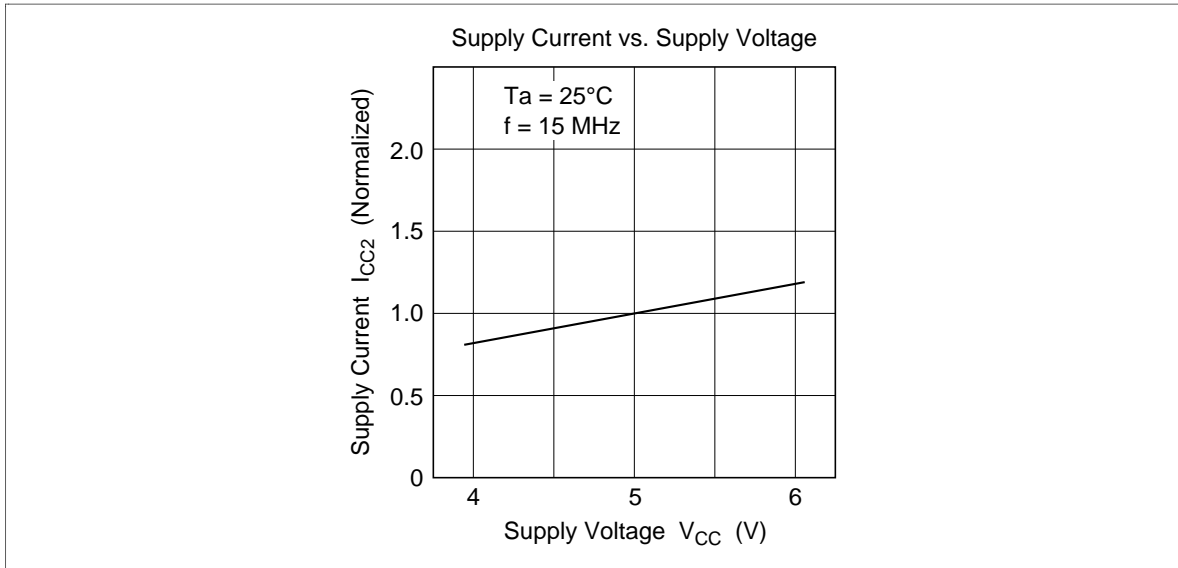

HN27C256HG Series

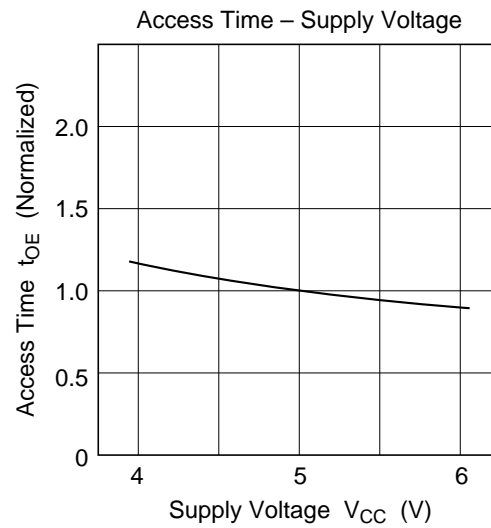
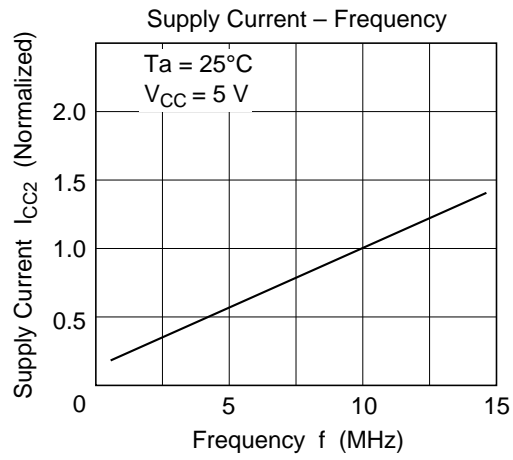

Electrical Characteristics Curves (Cont)

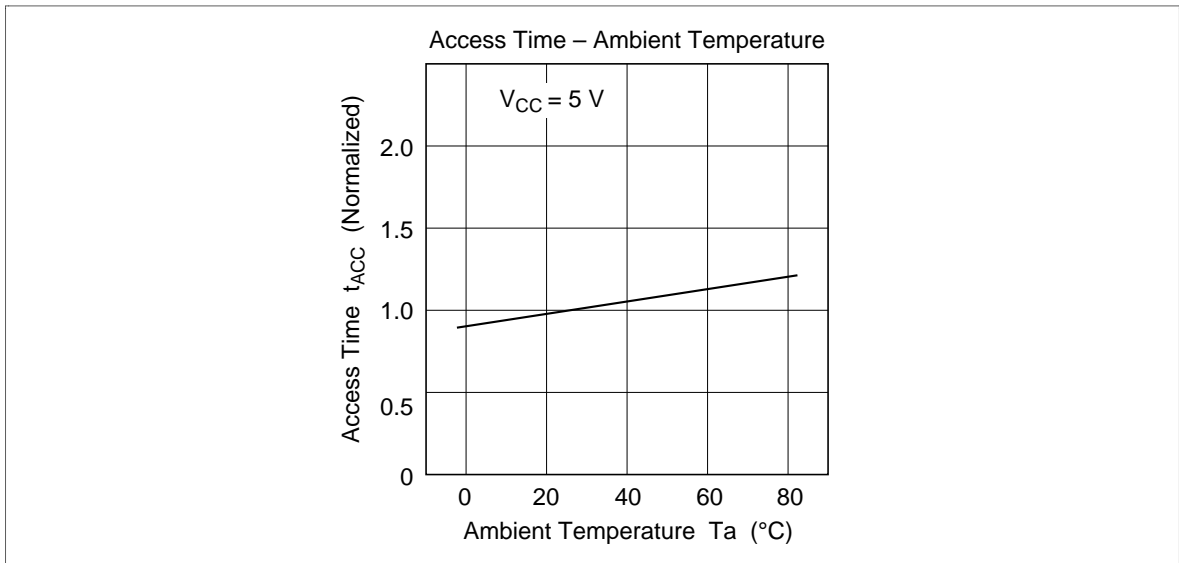
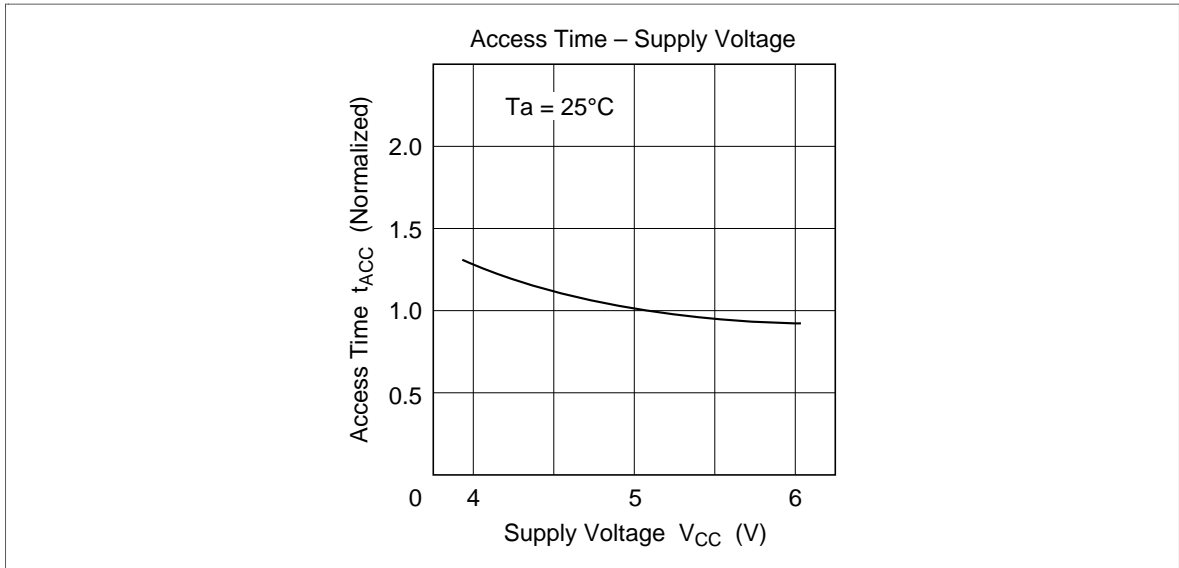

HN27C256HG Series

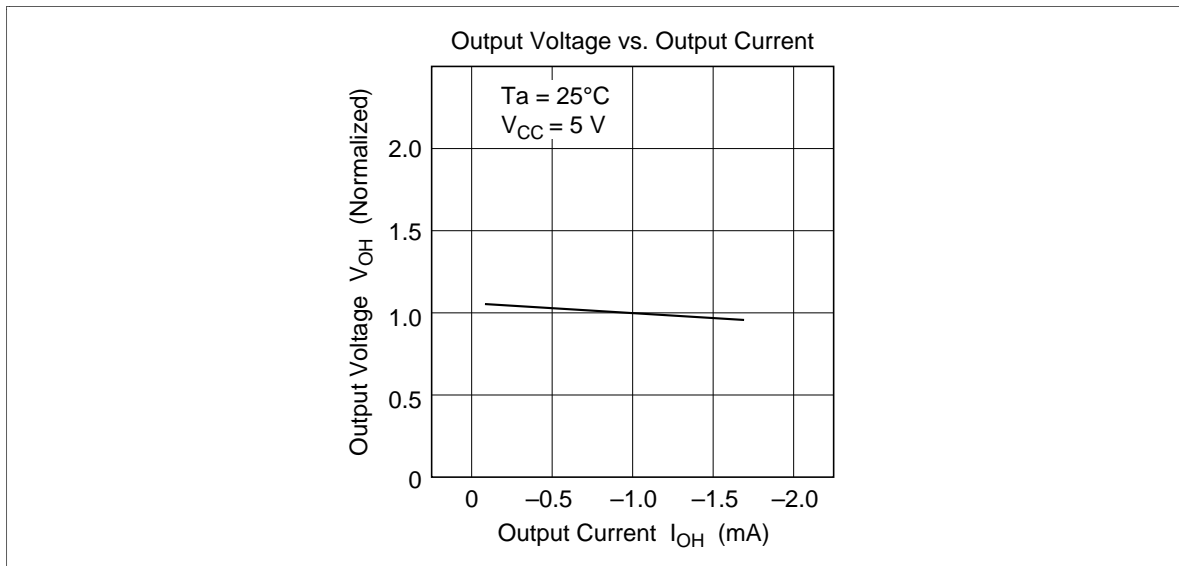
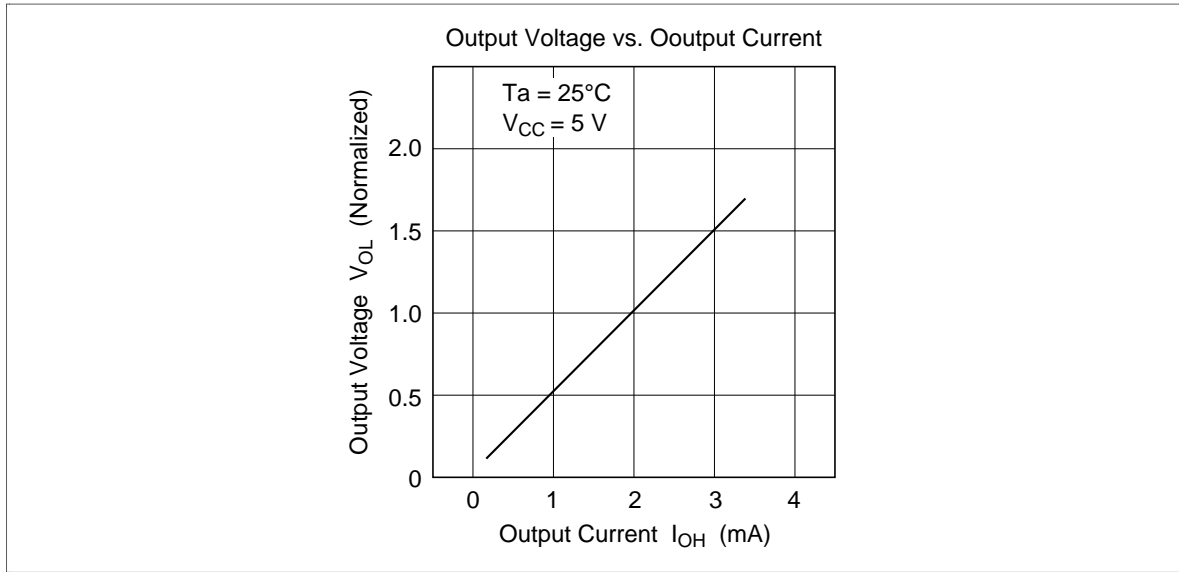

Electrical Characteristics Curves (Cont)

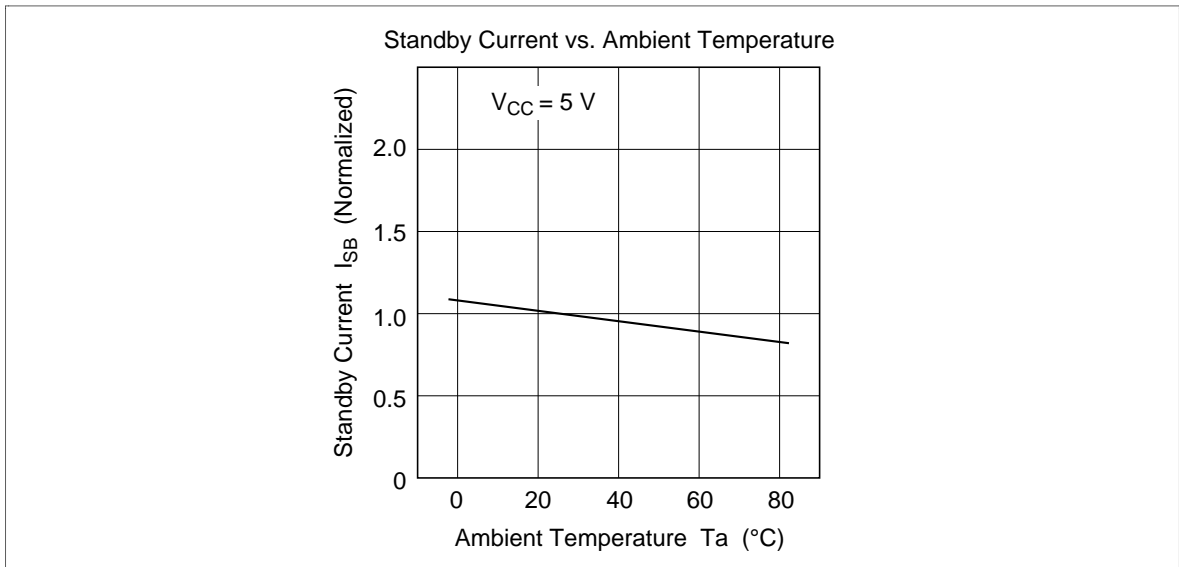
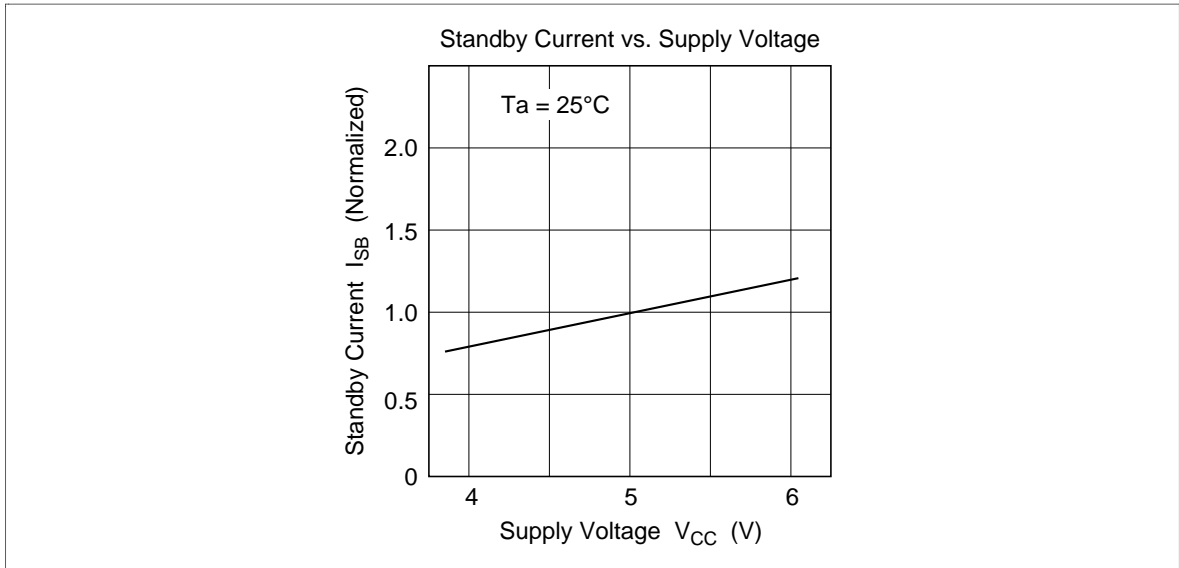

HN27C256HG Series

Package Dimensions

HN27C256HG Series (DG-28)

Unit: mm

