HN27C4096AG/ACC Series

262144-word × 16-bit CMOS UV Erasable and Programmable
ROM

HITACHI

Description

The Hitachi HN27C4096AG/ACC is a 4-Mbit ultraviolet erasable and electrically programmable ROM, featuring high speed and low power dissipation. Fabricated on advanced fine process and high speed circuitry technique, the HN27C4096A makes high speed access time possible. Therefore, it is suitable for 16-bit microcomputer systems using high speed microcomputer such as the 80286 and 68020. The HN27C4096A offers high speed programming using page programming mode. This device has the package variation of cerdip-40pin and JLCC-44pin.

Features

- High speed: Access time 100 ns/120 ns/150 ns (max)
- Low power dissipation:
 - Standby mode; 5 μ W (typ)
 - Active mode; 35 mW/MHz (typ)
- Fast high reliability page programming and fast high-reliability programming
 - Programming voltage; +12.5 V D.C.
 - Program time; 3.5 sec (min) (Theoretical in Page programming)
- Inputs and outputs TTL compatible during both read and program modes
- Pin arrangement: 40-pin JEDEC standard
 - 44-pin JLCC JEDEC standard
- Device identifier mode: Manufacturer code and device code
- Fully compatible with the HN27C4096G/CC Series

HN27C4096AG/ACC Series

Ordering Information

Type No.	Access Time	Package
HN27C4096AG-10	100 ns	600-mil 40-pin cerdip (DG-40A)
HN27C4096AG-12	120 ns	
HN27C4096AG-15	150 ns	
HN27C4096ACC-10	100 ns	44-pin J-bend leaded chip carrier (CC-44)
HN27C4096ACC-12	120 ns	
HN27C4096ACC-15	150 ns	

Pin Arrangement

HN27C4096AG Series

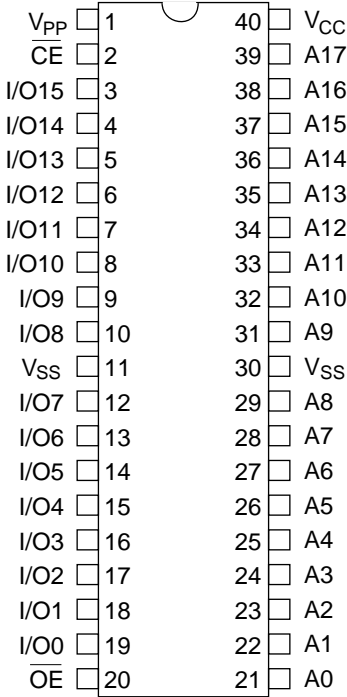

(Top view)

HN27C4096ACC Series

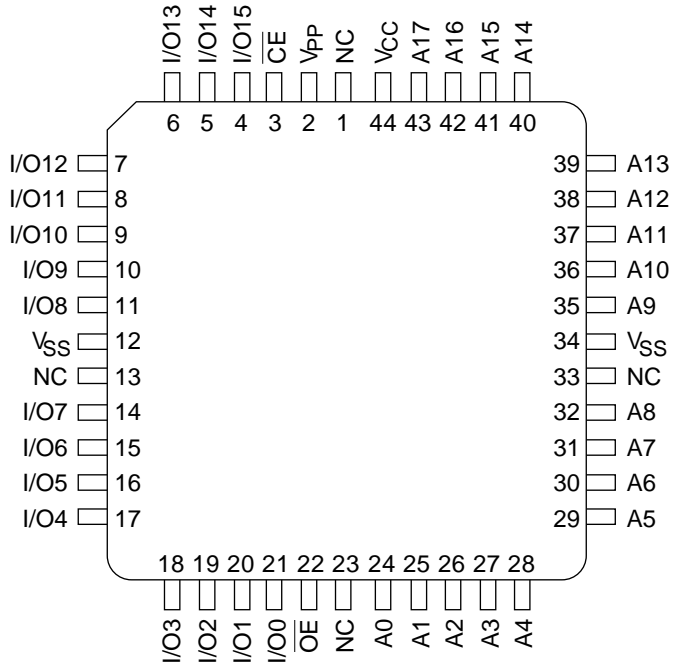

(Top view)

Pin Description

Pin Name	Function
A0 – A17	Address
I/O0 – I/O15	Input/output
$\overline{\text{CE}}$	Chip enable
$\overline{\text{OE}}$	Output enable
V _{CC}	Power supply
V _{PP}	Programming power supply
V _{SS}	Ground

Block Diagram

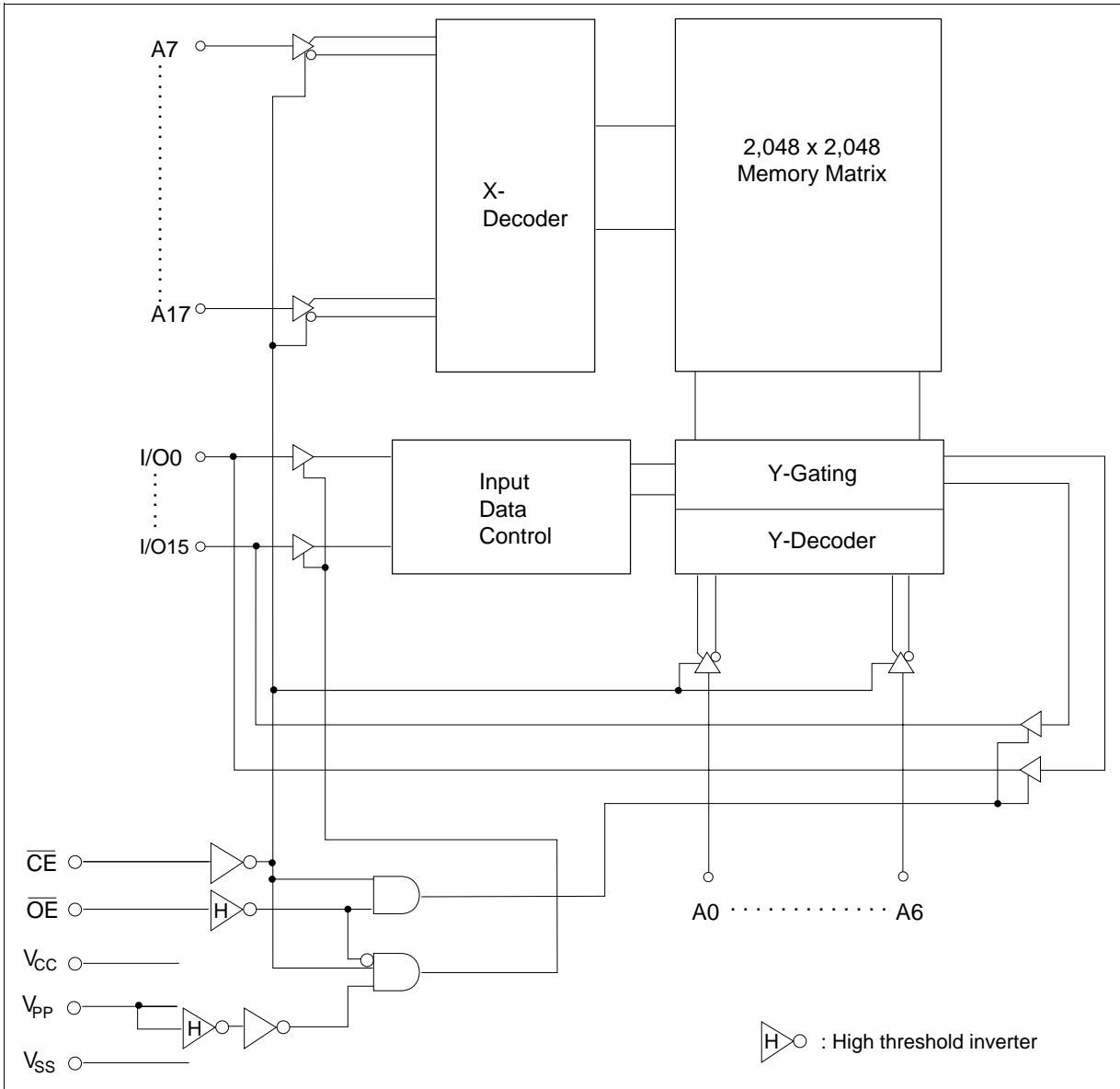

Mode Selection

	Pin	\overline{CE}	\overline{OE}	A9	V_{PP}	V_{CC}	I/O
	CC-44	(3)	(22)	(35)	(2)	(44)	(4 – 11, 14 – 21)
Mode	DG-40A	(2)	(20)	(31)	(1)	(40)	(3 – 10, 12 – 19)
Read		V_{IL}	V_{IL}	X	$V_{SS} - V_{CC}$	V_{CC}	Dout
Output disable		V_{IL}	V_{IH}	X	$V_{SS} - V_{CC}$	V_{CC}	High-Z
Standby		V_{IH}	X	X	$V_{SS} - V_{CC}$	V_{CC}	High-Z
Page program	Page program set	V_{IH}	V_H^{*2}	X	V_{PP}	V_{CC}	High-Z
	Page data latch	V_{IL}	V_H^{*2}	X	V_{PP}	V_{CC}	Din
	Page program	V_{IL}	V_{IH}	X	V_{PP}	V_{CC}	High-Z
	Page program verify	V_{IH}	V_{IL}	X	V_{PP}	V_{CC}	Dout
	Page program reset	V_{IH}	V_{IH}	X	V_{CC}	V_{CC}	High-Z
Word program	Program	V_{IL}	V_{IH}	X	V_{PP}	V_{CC}	Din
	Program verify	V_{IH}	V_{IL}	X	V_{PP}	V_{CC}	Dout
	Optional verify	V_{IL}	V_{IL}	X	V_{PP}	V_{CC}	Dout
	Program inhibit	V_{IH}	V_{IH}	X	V_{PP}	V_{CC}	High-Z
Identifier		V_{IL}	V_{IL}	V_H^{*2}	$V_{SS} - V_{CC}$	V_{CC}	Code

- Notes: 1. X: Don't care.
 2. V_H : 12.0 V \pm 0.5 V

Absolute Maximum Ratings

Parameter	Symbol	Value	Unit
All input and output voltages ¹	V_{in}, V_{out}	-0.6 ² to +7.0	V
Voltage on pin A9 and \overline{OE}	V_{ID}	-0.6 ² to +13.0	V
V_{PP} voltage ¹	V_{PP}	-0.6 to +13.5	V
V_{CC} voltage ¹	V_{CC}	-0.6 to +7.0	V
Operating temperature range	T_{opr}	0 to +70	°C
Storage temperature range ³	T_{stg}	-65 to +125	°C
Storage temperature under bias	T_{bias}	-20 to +80	°C

- Notes: 1. Relative to V_{SS} .
 2. V_{in}, V_{out}, V_{ID} min = -2.0 V for pulse width \leq 20 ns
 3. Storage temperature range of device before programming.

HN27C4096AG/ACC Series

Capacitance ($T_a = 25^\circ\text{C}$, $f = 1\text{ MHz}$)

Parameter	Symbol	Min	Typ	Max	Unit	Test Conditions
Input capacitance	C_{in}	—	—	12	pF	$V_{in} = 0\text{ V}$
Output capacitance	C_{out}	—	—	20	pF	$V_{out} = 0\text{ V}$

Read Operation

DC Characteristics ($V_{CC} = 5\text{ V} \pm 10\%$, $V_{PP} = V_{SS}$ to V_{CC} , $T_a = 0$ to $+70^\circ\text{C}$)

Parameter	Symbol	Min	Typ	Max	Unit	Test Conditions
Input leakage current	I_{LI}	—	—	2	μA	$V_{in} = 5.5\text{ V}$
Output leakage current	I_{LO}	—	—	2	μA	$V_{out} = 5.5\text{ V}/0.45\text{ V}$
V_{PP} current	I_{PP1}	—	1	20	μA	$V_{PP} = 5.5\text{ V}$
Standby V_{CC} current	I_{SB1}	—	—	1	mA	$\overline{CE} = V_{IH}$
	I_{SB2}	—	1	20	μA	$\overline{CE} = V_{CC} \pm 0.3\text{ V}$
Operating V_{CC} current	I_{CC1}	—	—	30	mA	$I_{out} = 0\text{ mA}$, $f = 1\text{ MHz}$
	I_{CC2}	—	—	100	mA	$I_{out} = 0\text{ mA}$, $f = 10\text{ MHz}$
Input voltage	V_{IL}	-0.3^{11}	—	0.8	V	
	V_{IH}	2.2	—	$V_{CC}+1^{12}$	V	
Output voltage	V_{OL}	—	—	0.45	V	$I_{OL} = 2.1\text{ mA}$
	V_{OH}	2.4	—	—	V	$I_{OH} = -400\text{ }\mu\text{A}$

Notes: 1. V_{IL} min = -1.0 V for pulse width $\leq 50\text{ ns}$

V_{IL} min = -2.0 V for pulse width $\leq 20\text{ ns}$

2. V_{IH} max = $V_{CC} + 1.5\text{ V}$ for pulse width $\leq 20\text{ ns}$

If V_{IH} is over the specified maximum value, read operation cannot be guaranteed.

AC Characteristics ($V_{CC} = 5\text{ V} \pm 10\%$, $V_{PP} = V_{SS}$ to V_{CC} , $T_a = 0$ to $+70^\circ\text{C}$)

Test Conditions

- Input pulse levels: 0.45 to 2.4 V
- Input rise and fall time: ≤ 10 ns
- Output load: 1 TTL gate +100 pF
- Reference levels for measuring timing: 0.8 V, 2.0 V

		HN27C4096A							
		-10		-12		-15			
Parameter	Symbol	Min	Max	Min	Max	Min	Max	Unit	Test Conditions
Address to output delay	t_{ACC}	—	100	—	120	—	150	ns	$\overline{CE} = \overline{OE} = V_{IL}$
\overline{CE} to output delay	t_{CE}	—	100	—	120	—	150	ns	$\overline{OE} = V_{IL}$
\overline{OE} to output delay	t_{OE}	—	60	—	60	—	70	ns	$\overline{CE} = V_{IL}$
\overline{OE} high to output float*1	t_{DF}	0	35	0	40	0	50	ns	$\overline{CE} = V_{IL}$
Address to output hold	t_{OH}	5	—	5	—	5	—	ns	$\overline{CE} = \overline{OE} = V_{IL}$

Note: 1. t_{DF} is defined as the time at which the output achieves the open circuit condition and data is no longer driven.

Read Timing Waveform

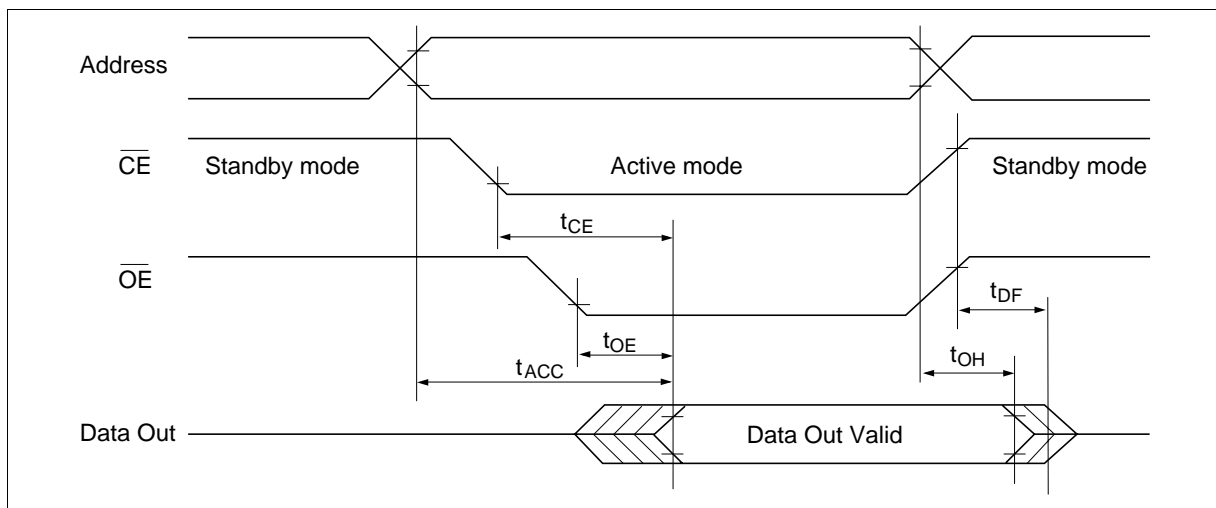

Fast High-Reliability Page Programming

This device can be applied the high performance page programming algorithm shown in the following flowchart. This algorithm allows to obtain faster programming time without any voltage stress to the device nor deterioration in reliability of programmed data.

Page Program Set

Apply 12 V to $\overline{\text{OE}}$ pin after applying 12.5 V to V_{pp} to set a page program mode.

The device operates in a page program mode until reset.

Page Program Reset

Set V_{PP} to V_{CC} level or less to reset a page program mode.

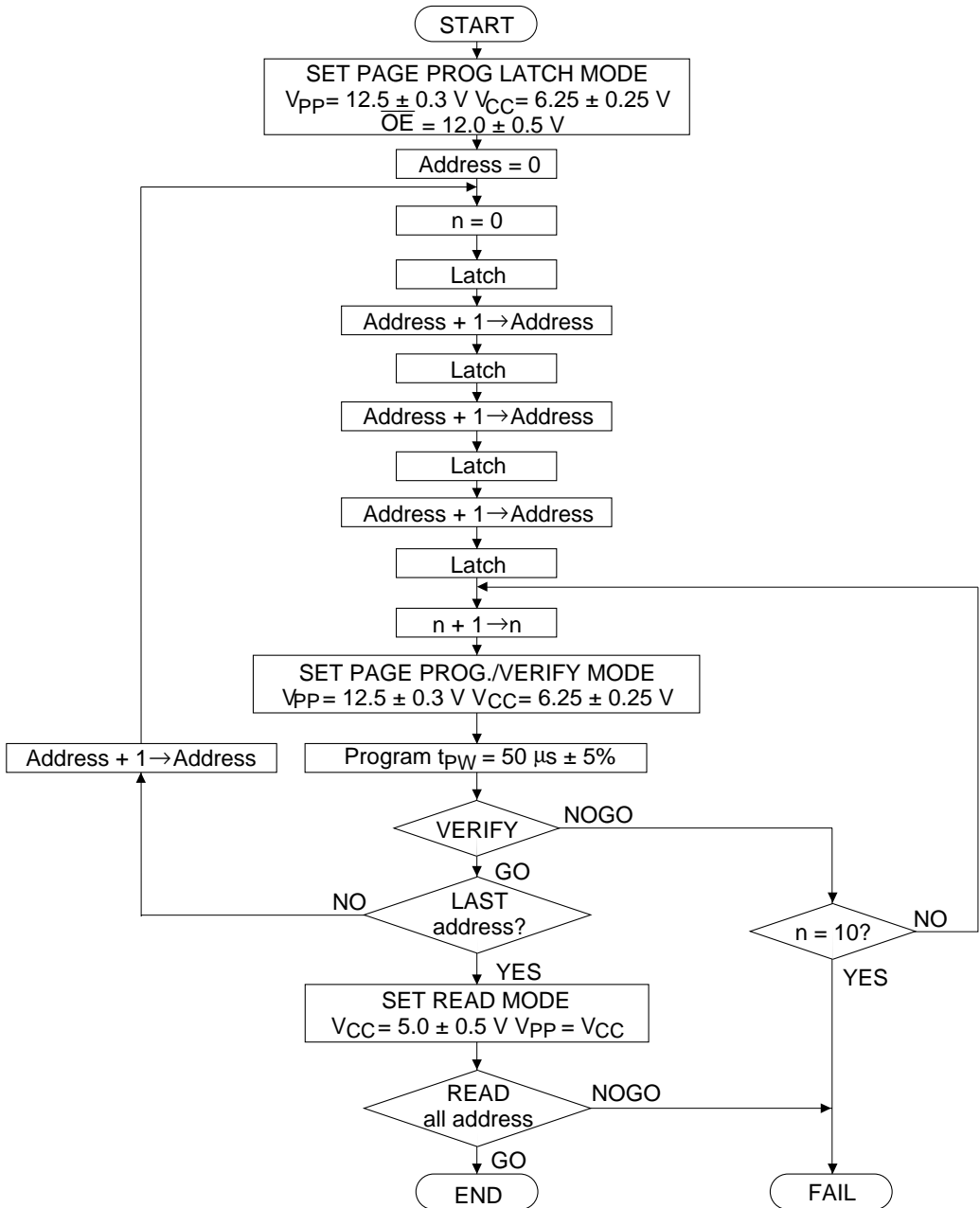

Fast High-Reliability Page Programming Flowchart

HN27C4096AG/ACC Series

DC Characteristics ($V_{CC} = 6.25 \text{ V} \pm 0.25 \text{ V}$, $V_{PP} = 12.5 \text{ V} \pm 0.3 \text{ V}$, $T_a = 25^\circ\text{C} \pm 5^\circ\text{C}$)

Parameter	Symbol	Min	Typ	Max	Unit	Test Conditions
Input leakage current	I_{LI}	—	—	2	μA	$V_{in} = 6.5 \text{ V}/0.45 \text{ V}$
Output voltage during verify	V_{OL}	—	—	0.45	V	$I_{OL} = 2.1 \text{ mA}$
	V_{OH}	2.4	—	—	V	$I_{OH} = -400 \mu\text{A}$
Operating V_{CC} current	I_{CC}	—	—	50	mA	
Input voltage	V_{IL}	-0.1^{*5}	—	0.8	V	
	V_{IH}	2.2	—	$V_{CC}+0.5^{*6}$	V	
	V_H	11.5	12.0	12.5	V	
V_{PP} supply current	I_{PP}	—	—	70	mA	$\overline{CE} = V_{IL}$

- Notes:
1. V_{CC} must be applied before V_{PP} and removed after V_{PP} .
 2. V_{PP} must not exceed 13 V including overshoot.
 3. An influence may be had upon device reliability if the device is installed or removed while $V_{PP} = 12.5 \text{ V}$.
 4. Do not alter V_{PP} either V_{IL} to 12.5 V or 12.5 V to V_{IL} when $\overline{CE} = \text{low}$.
 5. $V_{IL} \text{ min} = -0.6 \text{ V}$ for pulse width $\leq 20 \text{ ns}$.
 6. If V_{IH} is over the specified maximum value, programming operation cannot be guaranteed.

AC Characteristics ($V_{CC} = 6.25 \text{ V} \pm 0.25 \text{ V}$, $V_{PP} = 12.5 \text{ V} \pm 0.3 \text{ V}$, $T_a = 25^\circ\text{C} \pm 5^\circ\text{C}$)

Test Conditions

- Input pulse levels: 0.45 to 2.4 V
- Input rise and fall time: $\leq 20 \text{ ns}$
- Reference levels for measuring timing:
Inputs; 0.8 V, 2.0 V,
Outputs; 0.8 V, 2.0 V

Parameter	Symbol	Min	Typ	Max	Unit	Test Conditions
Address setup time	t_{AS}	2	—	—	μs	
\overline{OE} setup time	t_{OES}	2	—	—	μs	
Data setup time	t_{DS}	2	—	—	μs	
Address hold time	t_{AH}	0	—	—	μs	
Data hold time	t_{DH}	2	—	—	μs	
\overline{OE} high to output float delay	t_{DF}^{*1}	0	—	130	ns	
V_{PP} setup time	t_{VPS}	2	—	—	μs	
V_{CC} setup time	t_{VCS}	2	—	—	μs	
\overline{CE} programming pulse width	t_{PW}	47.5	50.0	52.5	μs	
\overline{CE} setup time	t_{CES}	2	—	—	μs	
Data valid from \overline{OE}	t_{OE}	0	—	150	ns	
\overline{CE} pulse width during data latch	t_{LW}	1	—	—	μs	
$\overline{OE} = V_H$ setup time	t_{OHS}	2	—	—	μs	
$\overline{OE} = V_H$ hold time	t_{OHH}	2	—	—	μs	
V_{PP} hold time ^{*2}	t_{VRS}	1	—	—	μs	

Notes: 1. t_{DF} is defined as the time at which the output achieves the open circuit condition and data is no longer driven.

2. Page program mode will be reset when V_{PP} is set to V_{CC} or less.

Fast High-Reliability Page Programming Timing Waveform

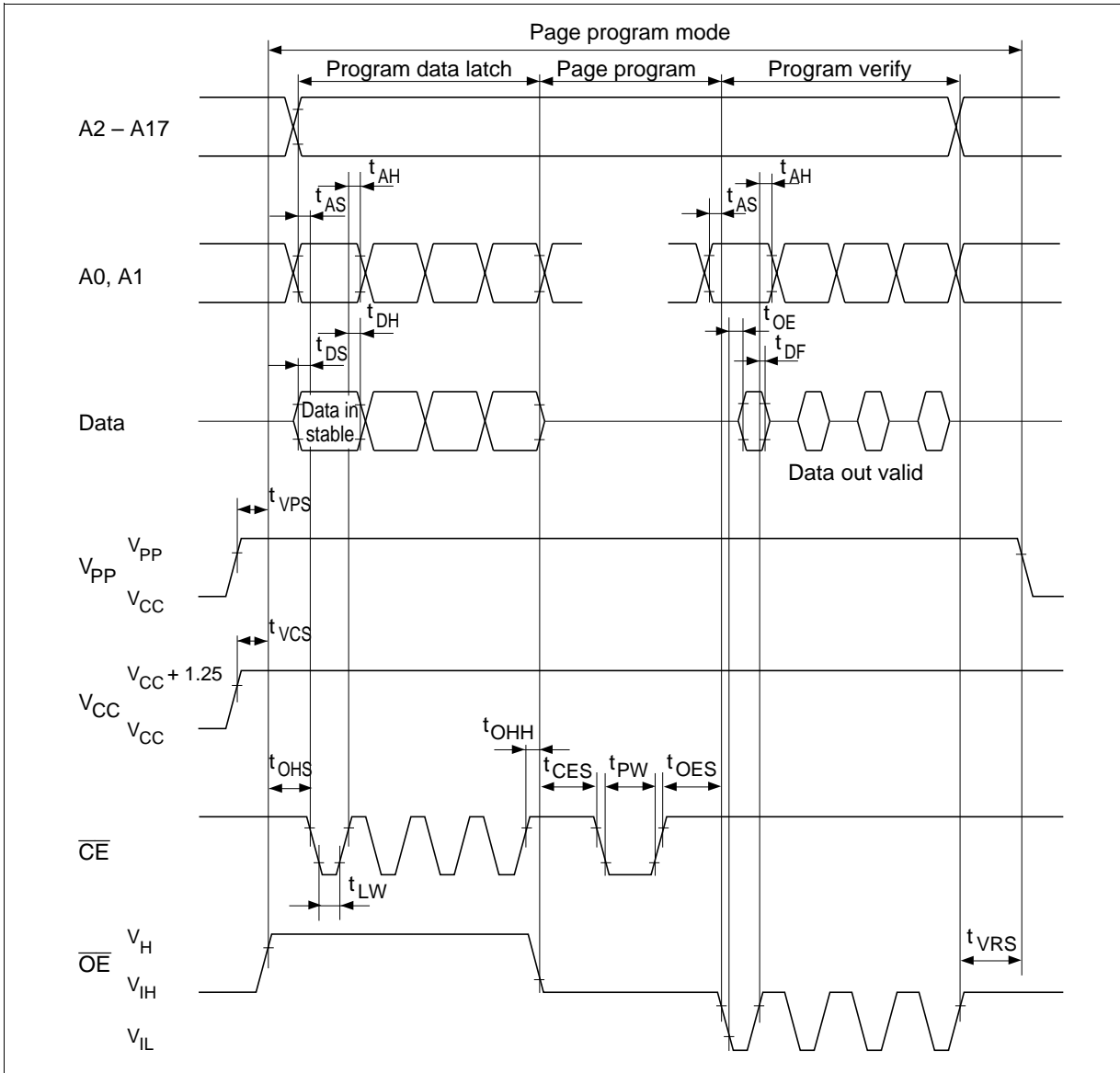

Fast High-Reliability Programming

This device can be applied the fast high-reliability programming algorithm shown in the following flowchart. This algorithm allows to obtain faster programming time without any voltage stress to the device nor deterioration in reliability of programmed data.

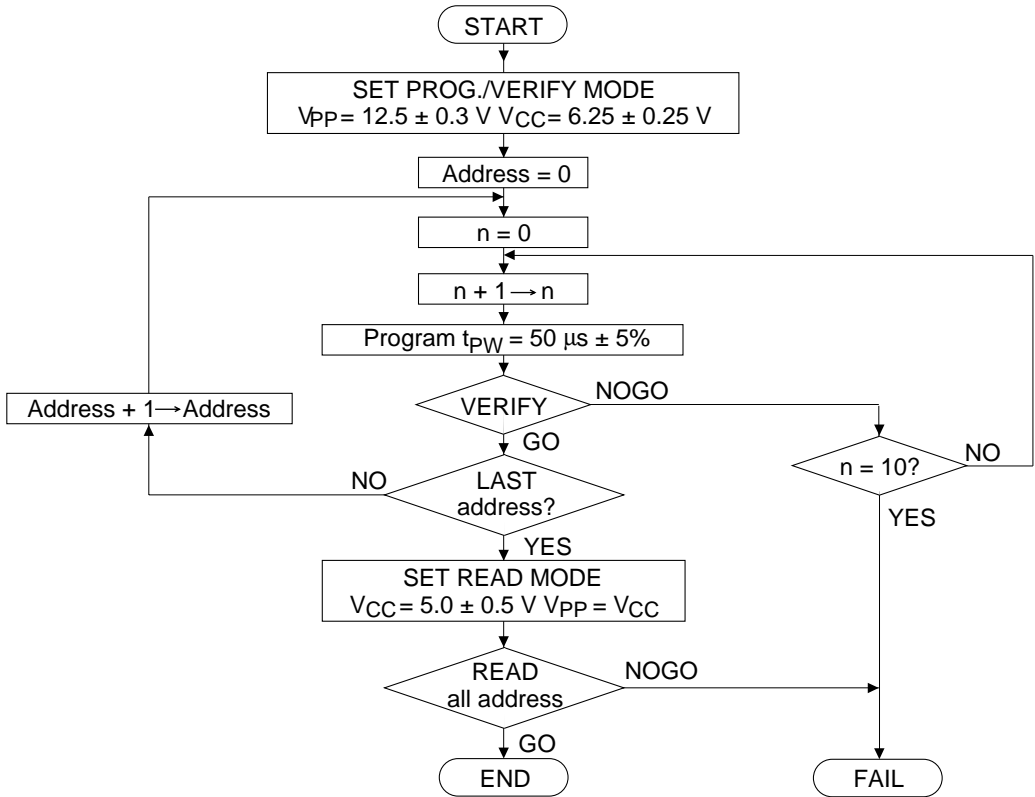

Fast High-Reliability Programming Flowchart

DC Characteristics ($V_{CC} = 6.25 \text{ V} \pm 0.25 \text{ V}$, $V_{PP} = 12.5 \text{ V} \pm 0.3 \text{ V}$, $T_a = 25^\circ\text{C} \pm 5^\circ\text{C}$)

Parameter	Symbol	Min	Typ	Max	Unit	Test Conditions
Input leakage current	I_{LI}	—	—	2	μA	$V_{in} = 6.5 \text{ V}/0.45 \text{ V}$
V_{PP} supply current	I_{PP}	—	—	40	mA	$\overline{CE} = V_{IL}$
Operating V_{CC} current	I_{CC}	—	—	50	mA	
Input voltage	V_{IL}	-0.1^{*5}	—	0.8	V	
	V_{IH}	2.2	—	$V_{CC} + 0.5^{*6}$	V	
Output voltage	V_{OL}	—	—	0.45	V	$I_{OL} = 2.1 \text{ mA}$
	V_{OH}	2.4	—	—	V	$I_{OH} = -400 \mu\text{A}$

- Notes:
1. V_{CC} must be applied before V_{PP} and removed after V_{PP} .
 2. V_{PP} must not exceed 13 V including overshoot.
 3. An influence may be had upon device reliability if the device is installed or removed while $V_{PP} = 12.5 \text{ V}$.
 4. Do not alter V_{PP} either V_{IL} to 12.5 V or 12.5 V to V_{IL} when $\overline{CE} = \text{low}$.
 5. $V_{IL} \text{ min} = -0.6 \text{ V}$ for pulse width $\leq 20 \text{ ns}$.
 6. If V_{IH} is over the specified maximum value, programming operation cannot be guaranteed.

AC Characteristics ($V_{CC} = 6.25\text{ V} \pm 0.25\text{ V}$, $V_{PP} = 12.5\text{ V} \pm 0.3\text{ V}$, $T_a = 25^\circ\text{C} \pm 5^\circ\text{C}$)

Test Conditions

- Input pulse levels: 0.45 to 2.4 V
- Input rise and fall time: $\leq 20\text{ ns}$
- Reference levels for measuring timings:
 Inputs: 0.8 V, 2.0 V
 Outputs: 0.8 V, 2.0 V

Parameter	Symbol	Min	Typ	Max	Unit	Test Conditions
Address setup time	t_{AS}	2	—	—	μs	
\overline{OE} setup time	t_{OES}	2	—	—	μs	
Data setup time	t_{DS}	2	—	—	μs	
Address hold time	t_{AH}	0	—	—	μs	
Data hold time	t_{DH}	2	—	—	μs	
\overline{OE} to output float delay	t_{DF}^{*1}	0	—	130	ns	
V_{PP} setup time	t_{VPS}	2	—	—	μs	
V_{CC} setup time	t_{VCS}	2	—	—	μs	
\overline{CE} programming pulse width	t_{PW}	47.5	50.0	52.5	μs	
Data valid from \overline{OE}	t_{OE}	0	—	150	ns	

Note: 1. t_{DF} is defined as the time at which the output achieves the open circuit condition and data is no longer driven.

Fast High-Reliability Programming Timing Waveform

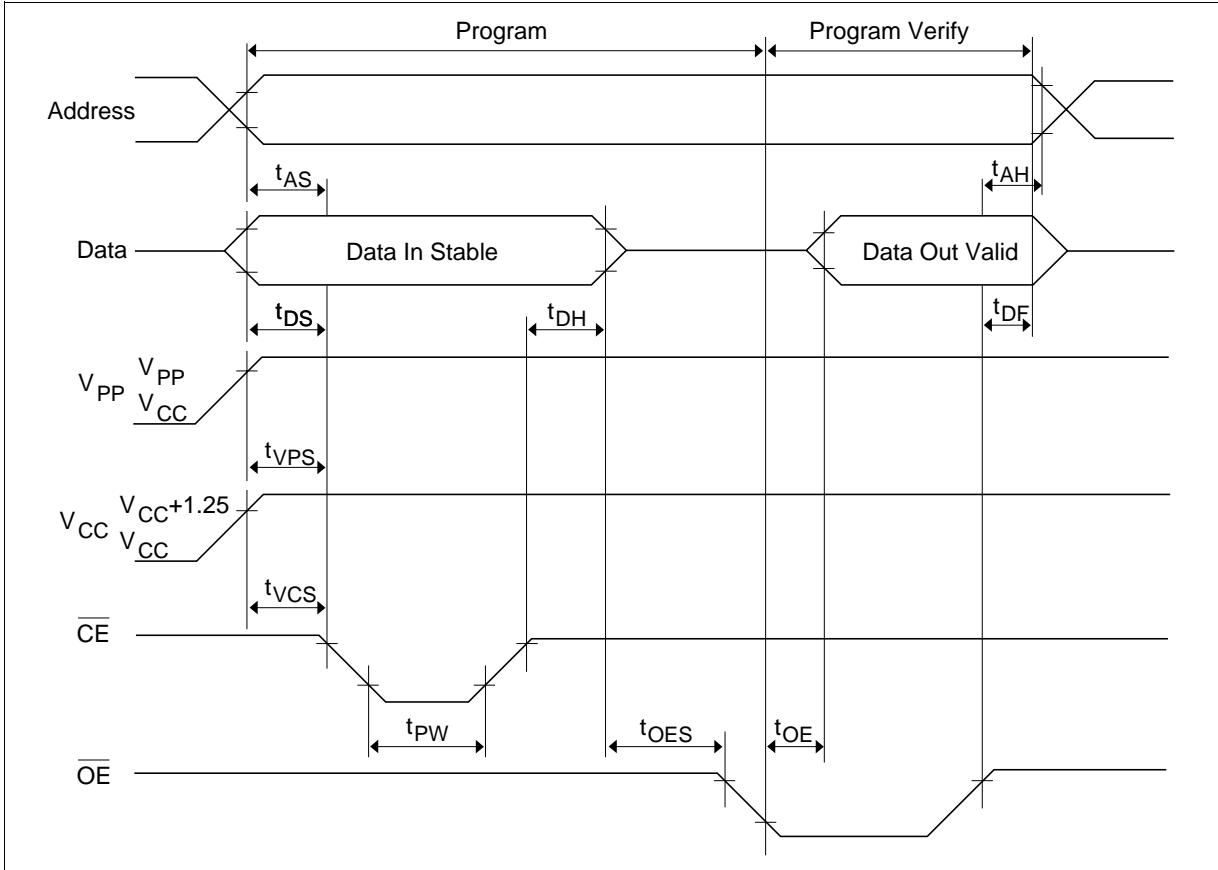

Optional Page Programming

This device can be applied the optional page programming algorithm shown in the following flowchart. This algorithm allows to obtain faster programming time without any voltage stress to the device nor deterioration in reliability of programmed data.

This programming algorithm is the combination of page programming and word verify. It can avoid the increase of programming verify time when a programmer with slow machine cycle is used, and shorten the total programming time.

Regarding the timing specifications for page programming and word verify, please refer to the specifications for fast high-reliability page programming and fast high-reliability programming.

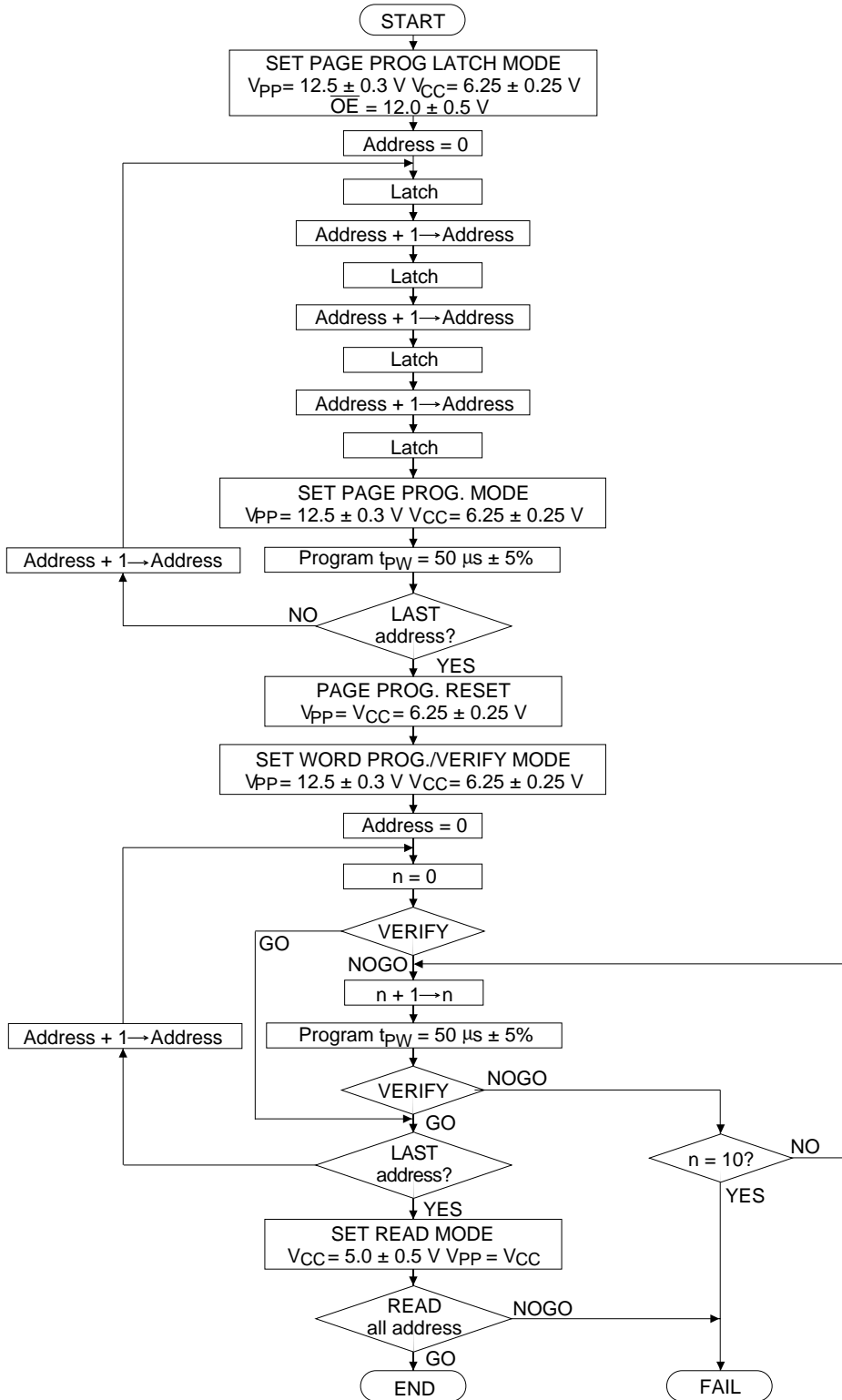

Optional Page Programming Flowchart

HN27C4096AG/ACC Series

DC Characteristics ($V_{CC} = 6.25 \text{ V} \pm 0.25 \text{ V}$, $V_{PP} = 12.5 \text{ V} \pm 0.3 \text{ V}$, $T_a = 25^\circ\text{C} \pm 5^\circ\text{C}$)

Parameter	Symbol	Min	Typ	Max	Unit	Test Conditions
Input leakage current	I_{LI}	—	—	2	μA	$V_{in} = 6.5 \text{ V}/0.45 \text{ V}$
Output voltage during verify	V_{OL}	—	—	0.45	V	$I_{OL} = 2.1 \text{ mA}$
	V_{OH}	2.4	—	—	V	$I_{OH} = -400 \mu\text{A}$
Operating V_{CC} current	I_{CC}	—	—	50	mA	
Input voltage	V_{IL}	-0.1^{15}	—	0.8	V	
	V_{IH}	2.2	—	$V_{CC} + 0.5^{16}$	V	
	V_H	11.5	12.0	12.5	V	
V_{PP} supply current	I_{PP}	—	—	70	mA	$\overline{CE} = V_{IL}$

- Notes:
1. V_{CC} must be applied before V_{PP} and removed after V_{PP} .
 2. V_{PP} must not exceed 13 V including overshoot.
 3. An influence may be had upon device reliability if the device is installed or removed while $V_{PP} = 12.5 \text{ V}$.
 4. Do not alter V_{PP} either V_{IL} to 12.5 V or 12.5 V to V_{IL} when $\overline{CE} = \text{low}$.
 5. $V_{IL} \text{ min} = -0.6 \text{ V}$ for pulse width $\leq 20 \text{ ns}$.
 6. If V_{IH} is over the specified maximum value, programming operation cannot be guaranteed.

AC Characteristics ($V_{CC} = 6.25 \text{ V} \pm 0.25 \text{ V}$, $V_{PP} = 12.5 \text{ V} \pm 0.3 \text{ V}$, $T_a = 25^\circ\text{C} \pm 5^\circ\text{C}$)

Test Conditions

- Input pulse levels: 0.45 to 2.4 V
- Input rise and fall time: $\leq 20 \text{ ns}$
- Reference levels for measuring timings:
 Inputs; 0.8 V, 2.0 V
 Outputs; 0.8 V, 2.0 V

Parameter	Symbol	Min	Typ	Max	Unit	Test Conditions
Address setup time	t_{AS}	2	—	—	μs	
$\overline{\text{OE}}$ setup time	t_{OES}	2	—	—	μs	
Data setup time	t_{DS}	2	—	—	μs	
Address hold time	t_{AH}	0	—	—	μs	
Data hold time	t_{DH}	2	—	—	μs	
$\overline{\text{OE}}$ high to output float delay	t_{DF}^{*1}	0	—	130	ns	
V_{PP} setup time	t_{VPS}	2	—	—	μs	
V_{CC} setup time	t_{VCS}	2	—	—	μs	
$\overline{\text{CE}}$ initial programming pulse width	t_{PW}	47.5	50.0	52.5	μs	
$\overline{\text{CE}}$ setup time	t_{CES}	2	—	—	μs	
Data valid from $\overline{\text{OE}}$	t_{OE}	0	—	150	ns	
$\overline{\text{CE}}$ pulse width during data latch	t_{LW}	1	—	—	μs	
$\overline{\text{OE}} = V_H$ setup time	t_{OHS}	2	—	—	μs	
$\overline{\text{OE}} = V_H$ hold time	t_{OHH}	2	—	—	μs	
Page programming reset time ^{*2}	t_{VLW}	1	—	—	μs	
V_{PP} hold time ^{*2}	t_{VRS}	1	—	—	μs	

Notes: 1. t_{DF} is defined as the time at which the output achieves the open circuit condition and data is no longer driven.

2. Page program mode will be reset when V_{PP} is set to V_{CC} or less.

Option Page Programming Timing Waveform

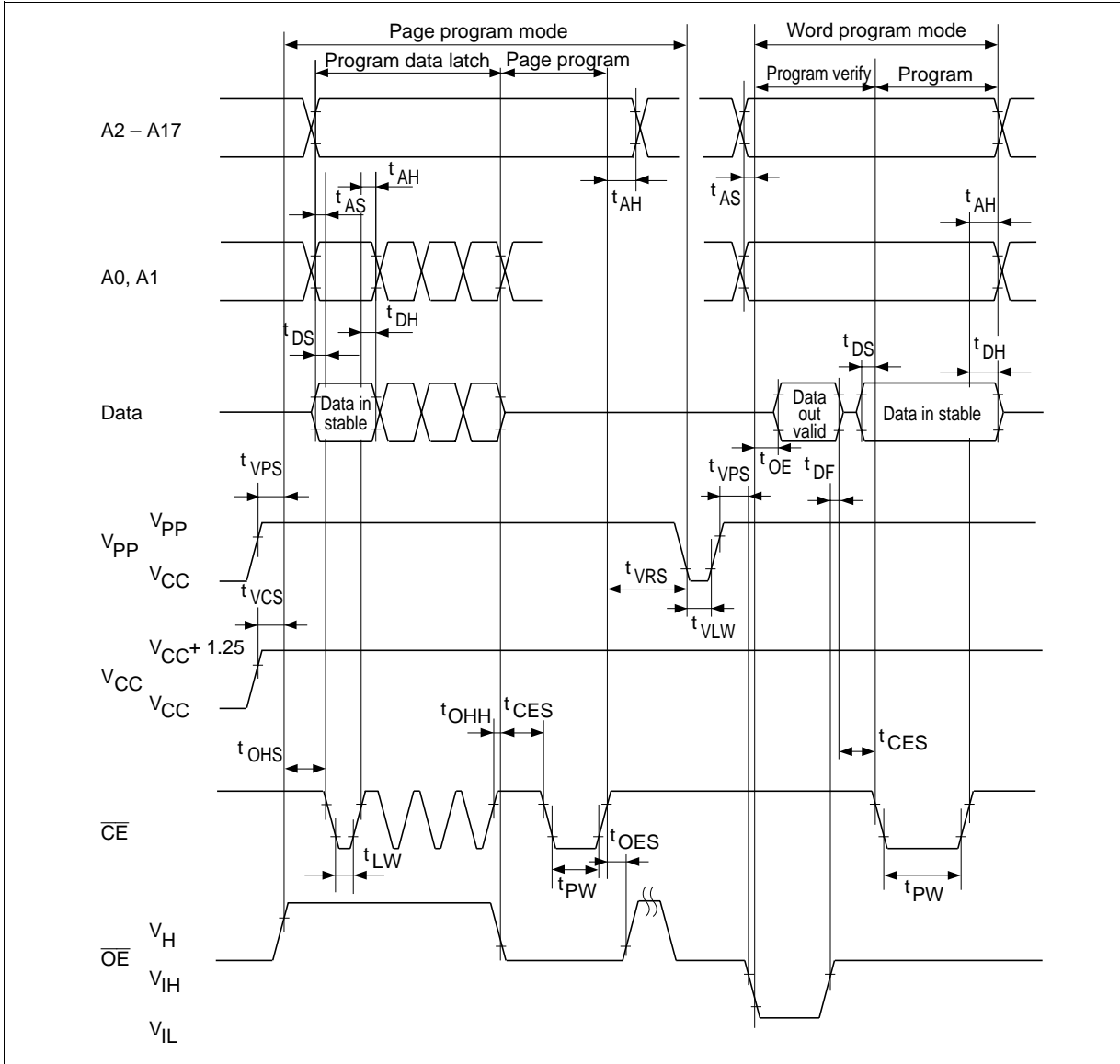

Erase

Erasure of the HN27C4096AG/ACC is performed by exposure to ultraviolet light of 2537 Å and all the output data are changed to "1" after this erasure procedure. The minimum integrated dose (i.e. UV intensity X exposure time) for erasure is 15 W · sec/cm².

Mode Description

Device Identifier Mode

The device identifier mode allows the reading out of binary codes that identify manufacturer and type of device, from outputs of EPROM. By this mode, the device will be automatically matched its own corresponding programming algorithm, using programming equipment.

HN27C4096A Identifier Code

	A0	I/O8 – I/O15	I/O7	I/O6	I/O5	I/O4	I/O3	I/O2	I/O1	I/O0	
	CC-44 (24)	(11 – 4)	(14)	(15)	(16)	(17)	(18)	(19)	(20)	(21)	
Identifier	DG-40A (21)	(10 – 3)	(12)	(13)	(14)	(15)	(16)	(17)	(18)	(19)	Hex Data
Manufacturer code	V_{IL}	X	0	0	0	0	0	1	1	1	07
Device code	V_{IH}	X	1	0	1	0	0	0	1	0	A2

- Notes: 1. $V_{CC} = 5.0\text{ V} \pm 10\%$
 2. $A9 = 12.0\text{ V} \pm 0.5\text{ V}$
 3. $A1 - A8, A10 - A17, \overline{CE}, \overline{OE} = V_{IL}$
 4. X: Don't care.

HN27C4096AG/ACC Series

Package Dimensions

HN27C4096HG Series (DG-40A)

Unit: mm

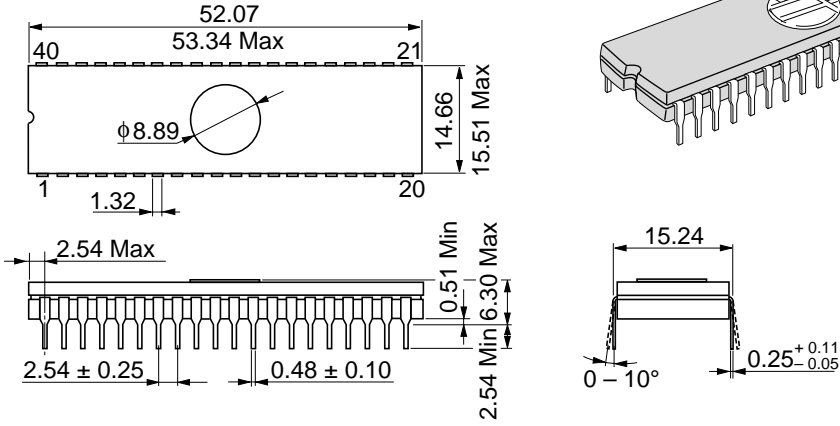

HN27C4096HCC Series (CC-44)

Unit: mm

