

HN462532

4096-word X 8-bit UV Erasable and Programmable Read Only Memory

The HN462532 is a 4096 word by 8 bit erasable and electrically programmable ROM. This device is packaged in a 24-pin, dual-in-line package with transparent lid. The transparent lid allows the user to expose the chip to ultraviolet light to erase the bit pattern, whereby a new pattern can then be written into the device.

■ FEATURES

- Single Power Supply +5V \pm 5%
- Simple Programming Program Voltage: +25V D.C.
Program with One 50ms Pulse
- Static No Clocks Required
- Inputs and Outputs TTL Compatible During Both Read and Program Modes
- Fully Decoded On-Chip Address Decode
- Access Time 450ns (Max.)
- Low Power Dissipation 858mW (Max.) Active Power
201mW (Max.) Standby Power
- Three State Output OR-Tie Capability
- Compatible with TMS2532

■ BLOCK DIAGRAM

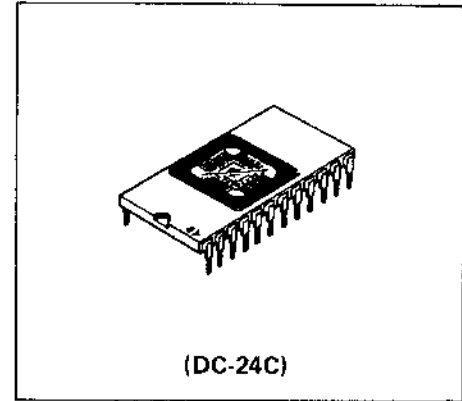
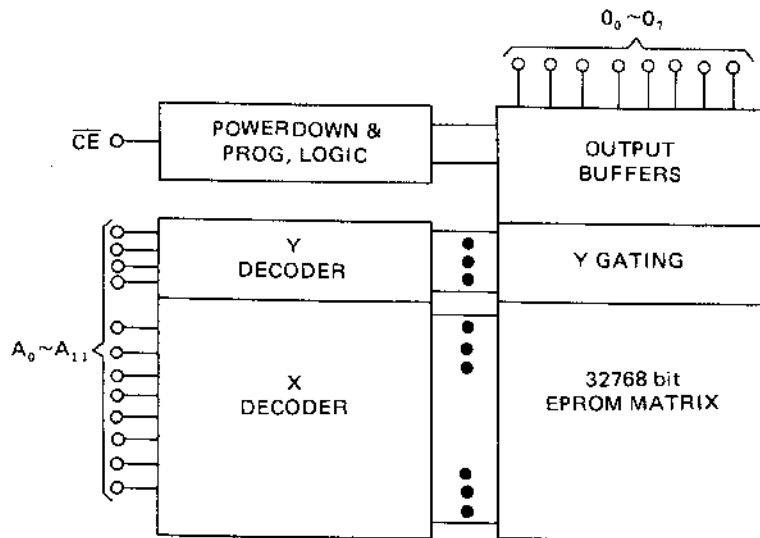

■ PIN ARRANGEMENT

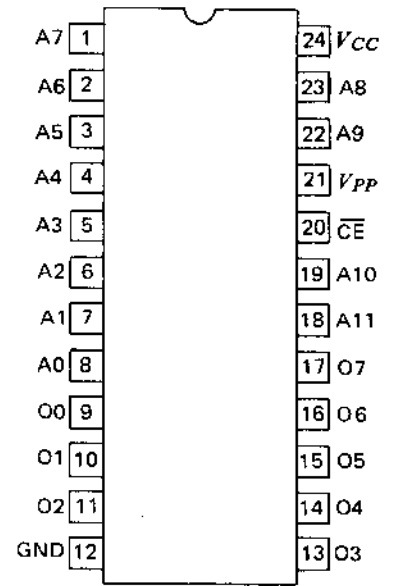

(Top View)

MODE SELECTION

Mode	Pins	\overline{CE} (20)	V_{PP} (21)	V_{CC} (24)	Outputs (9 to 11, 13 to 17)
Read		V_{IL}	+5	+5	Dout
Stand by		V_{IH}	+5	+5	High Z
Program		Pulsed V_{IH} to V_{IL}	+25	+5	Din
Program Inhibit		V_{IH}	+25	+5	High Z

ABSOLUTE MAXIMUM RATINGS

Item	Symbol	Value	Unit
All Input and Output Voltages*	V_{IN}, V_{out}	-0.3 to +7	V
V_{PP} Voltage*	V_{PP}	-0.3 to +28	V
Operating Temperature Range	T_{opr}	0 to +70	°C
Storage Temperature Range	T_{stg}	-65 to +125	°C

*with respect to GND.

READ OPERATION

D.C. AND OPERATING CHARACTERISTICS ($T_a = 0$ to +70°C, $V_{CC} = 5V \pm 5\%$, $V_{PP} = V_{CC} \pm 0.6V$)

Parameter	Symbol	Test Conditions	min.	typ.	max.	Unit
Input Leakage Current	I_{LI}	$V_{in} = 5.25V$	-	-	10	μA
Output Leakage Current	I_{LO}	$V_{out} = 5.25V / 0.4V$	-	-	10	μA
V_{PP} Current	I_{PP1}	$V_{PP} = 5.85V$	-	-	12	mA
V_{CC} Current (Standby)	I_{CC1}	$\overline{CE} = V_{IH}$	-	-	25	mA
V_{CC} Current (Active)	I_{CC2}	$\overline{CE} = V_{IL}$	-	-	150	mA
Input Low Voltage	V_{IL}		-0.1	-	0.8	V
Input High Voltage	V_{IH}		2.0	-	$V_{CC} + 1$	V
Output Low Voltage	V_{OL}	$I_{OL} = 2.1 mA$	-	-	0.4	V
Output High Voltage	V_{OH}	$I_{OH} = -400\mu A$	2.4	-	-	V

Notes: V_{CC} must be applied simultaneously or before V_{PP} and removed simultaneously or after V_{PP} .

AC CHARACTERISTICS ($T_a = 0$ to +70°C, $V_{CC} = 5V \pm 5\%$, $V_{PP} = V_{CC} \pm 0.6V$)

Parameter	Symbol	Test Conditions	min.	typ.	max.	Unit
Address to Output Delay	t_{ACC}	$\overline{CE} = V_{IL}$	-	-	450	ns
\overline{CE} to Output Delay	t_{CE}		-	-	450	ns
\overline{CE} High to Output Float	t_{DF}		0	-	100	ns
Address to Output Hold	t_{OH}	$\overline{CE} = V_{IL}$	0	-	-	ns

● SWITCHING CHARACTERISTICS

Test Conditions

Input Pulse Levels: 0.8V to 2.2V
 Input Rise and Fall Times: $\leq 20\text{ns}$
 Output Load: 1TTL Gate + 100pF
 Reference Level for Measuring Timing: Inputs; 1V and 2V, Outputs; 0.8V and 2V

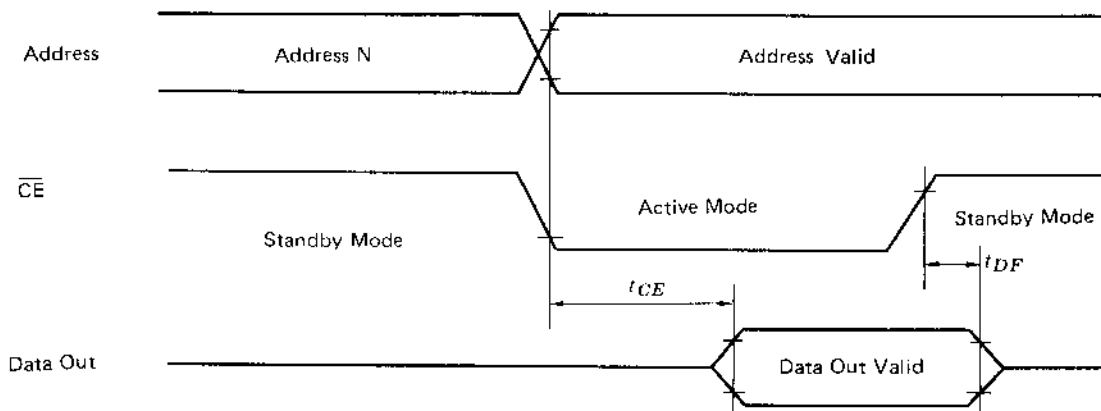

● CAPACITANCE ($T_a = 25^\circ\text{C}, f = 1\text{ MHz}$)

Parameter	Symbol	Test Conditions	min.	typ.	max.	Unit
Input Capacitance	C_{in}	$V_{in} = 0\text{V}$	—	—	6	pF
Output Capacitance	C_{out}	$V_{out} = 0\text{V}$	—	—	12	pF

■ PROGRAMMING OPERATION

● DC PROGRAMMING CHARACTERISTICS ($T_a = 25^\circ\text{C} \pm 5^\circ\text{C}, V_{CC} = 5\text{V} \pm 5\%, V_{PP} = 25\text{V} \pm 1\text{V}$)

Parameter	Symbol	Test Conditions	min.	typ.	max.	Unit
Input Leakage Current	I_{LI}	$V_{in} = 5.25\text{V} / 0.4\text{V}$	—	—	10	μA
V_{PP} Supply Current During Programming	I_{PP2}	$\overline{CE} = V_{IL}$	—	—	30	mA
V_{CC} Supply Current	I_{CC}		—	—	150	mA
Input Low Level	V_{IL}		-0.1	—	0.8	V
Input High Level	V_{IH}		2.0	—	$V_{CC} + 1$	V

● **AC PROGRAMMING CHARACTERISTICS** ($T_a = 25^\circ\text{C} \pm 5^\circ\text{C}$, $V_{CC} = 5\text{V} \pm 5\%$, $V_{PP} = 25\text{V} \pm 1\text{V}$)

Parameter	Symbol	Test Conditions	min.	typ.	max.	Unit
Address Setup Time	t_{AS}		2	—	—	μs
Data Setup Time	t_{DS}		2	—	—	μs
Address Hold Time	t_{AH}		2	—	—	μs
Data Hold Time	t_{DH}		2	—	—	μs
Setup Time from V_{PP}	t_{VPPS}		0	—	—	ns
Program Pulse Hold Time	t_{PRH}		0	—	—	ns
V_{PP} Hold Time	t_{VPPH}		0	—	—	ns
Program Pulse Width	t_{PW}		45	50	55	ms
Program Pulse Time	t_{PRT}		5	—	—	ns
Program Pulse Time	t_{PFT}		5	—	—	ns

Note: V_{CC} must be applied simultaneously or before V_{PP} and removed simultaneously or after V_{PP} .

● **SWITCHING CHARACTERISTICS**

Test Conditions

- Input Pulse Level: 0.8V to 2.2V
- Input Rise and Fall Times: $\leq 20\text{ns}$
- Output Load: 1TTL Gate + 100pF
- Reference Level for Measuring Timing: Inputs; 1V and 2V, Outputs; 0.8V and 2V

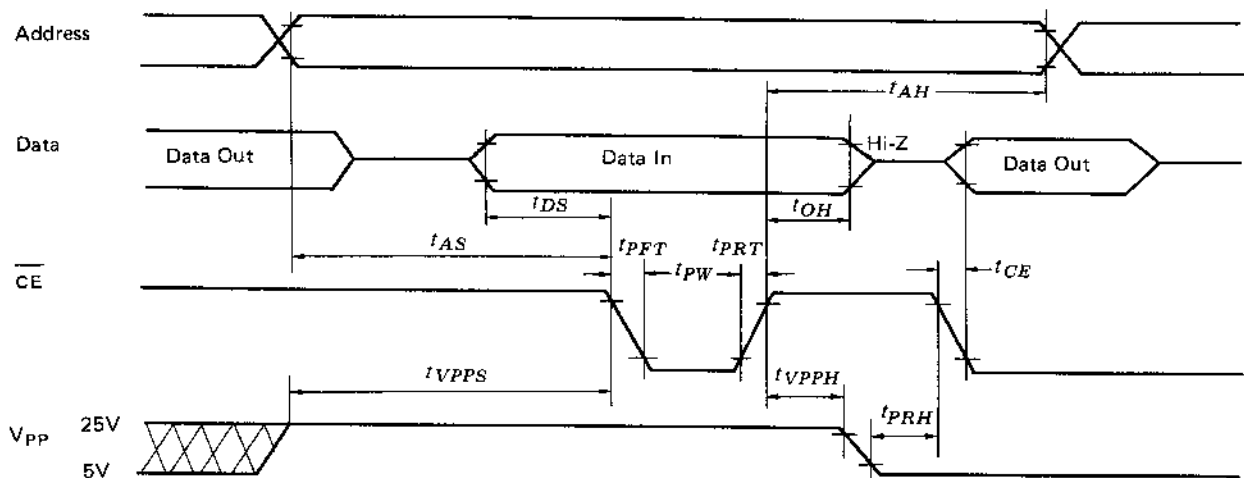

● **ERASE**

Erase of HN462532 is performed by exposure to ultraviolet light with a wavelength of 2537Å, and all the output data are changed to "1" after this erasure procedure.

The minimum integrated dose (i.e., UV intensity x exposure time) for erasure is 15W·sec/cm².