

**ALTIMETER**

**BAROMETER**

**THERMOMETER**

# I<sup>2</sup>C Precision Barometer and Altimeter Sensor

## Key Features

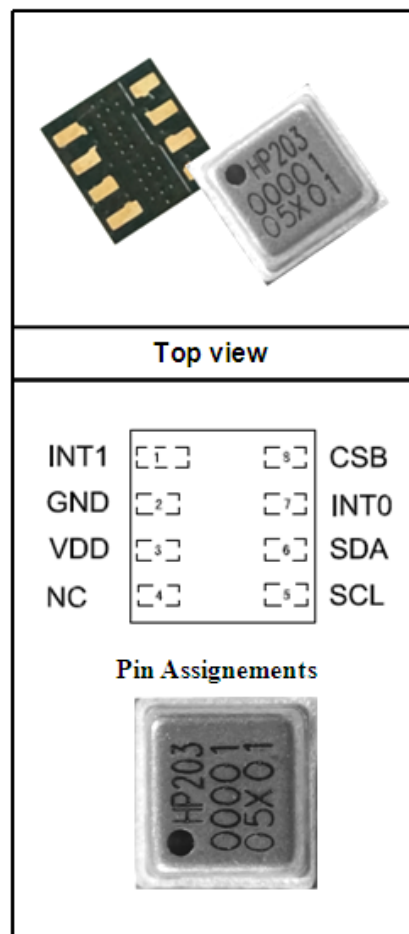
- ◆ Supply voltage 1.8V to 3.6V
- ◆ Pressure range: 300mbar~1200mbar
- ◆ Operation temperature: -40 to +85°C
- ◆ Programmable events and interrupt controls
- ◆ Altitude resolution: 0.1 meter
- ◆ High-speed I<sup>2</sup>C digital output interface (Up to 10 MHz)
- ◆ Fast conversion down to 2ms
- ◆ Standby current < 0.1uA, low conversion power, 2uA at 1 sample/sec.
- ◆ Size: 3.6 mm × 3.8 mm × 1.2 mm

## Applications

- ◆ Mobile altimeter / barometer
- ◆ Industrial pressure and temperature sensor system
- ◆ Adventure and sports watches
- ◆ Weather station equipment
- ◆ Indoor navigation and map assist
- ◆ Data loggers for pressure, temperature and altitude.
- ◆ Panel computer.

## Descriptions

The HP203B employs a MEMS pressure sensor with an I<sup>2</sup>C interface to provide accurate temperature, pressure or altitude data. The sensor pressure and temperature outputs are digitized by a high resolution 24-bit ADC. The altitude value is calculated by a specific patented algorithm according to the pressure and temperature data. Data compensation is integrated internally to save the effort of the external host MCU system. Easy command-based data acquisition interface and programmable interrupt control is available. Typical active supply current is 5.3 uA per measurement-second while the ADC output is filtered and decimated by 256. Pressure output can be resolved with output in fractions of a Pascal, and altitude can be resolved in 0.01 meter. The HP203B is offered in a 3.6mm x 3.8 mm x 1.2 mm package and specified for operation from -40°C to +85°C.



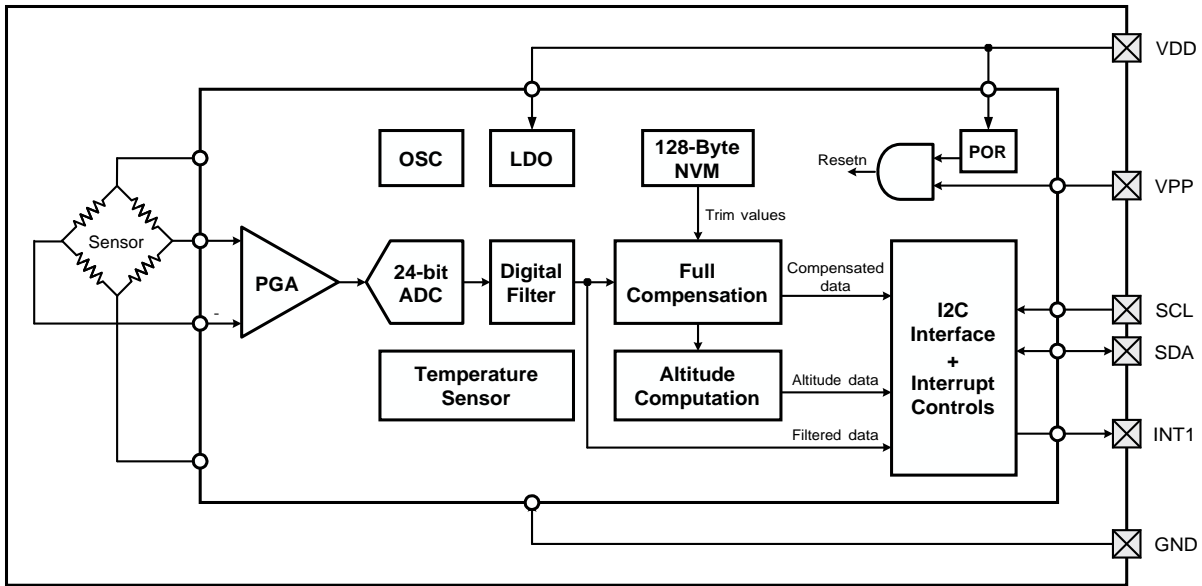


Figure 1: Functional block diagram

Table.1 – Pin Descriptions

Pin	Name	I/O	Function
1	INT1	O	Interrupt 1 output pin
2	GND	I	Ground input pin
3	VDD	I	1.8-3.6V power supply input pin
4	NC	-	NO Connect
5	SCL	I	I <sup>2</sup> C serial clock input pin
6	SDA	IO	I <sup>2</sup> C serial bi-directional data pin
7	INT0	O	Interrupt 0 output pin
8	CSB	I	I <sup>2</sup> C device address select pin (GND:0x77; VDD:0x76)

## 1. Electrical Characteristics

$V_{DD}=3\text{ V}$ ,  $T=25^{\circ}\text{C}$  unless otherwise noted

**Table 2: DC Characteristics**

Parameter	Symbol	Conditions	Min	Typ	Max	Unit
Operation Supply Voltage	$V_{DD}$		1.8	3.3	3.6	V
Operation Temperature	$T_{OP}$		-40	25	85	$^{\circ}\text{C}$
Average Operation Current (Pressure Measurement under One Conversion per Second)	$I_{DDAVP}$	OSR*	4096	91.8		uA
			2048	45.9		
			1024	22.9		
			512	11.4		
			256	5.7		
			128	2.9		
Average Operation Current (Temperature Measurement under One Conversion per Second)	$I_{DDAVT}$	OSR*	4096	75.4		uA
			2048	37.7		
			1024	18.8		
			512	9.4		
			256	4.7		
			128	2.4		
Conversion Time of Pressure or Temperature	$t_{CONV}$	OSR*	4096	65.6	78.7	ms
			2048	32.8	39.4	
			1024	16.4	19.7	
			512	8.2	9.8	
			256	4.1	4.9	
			128	2.1	2.5	
Peak Current	$I_{PEAK}$	During conversion		1.3		mA
Standby Supply Current	$I_{DDSTB}$	At $25^{\circ}\text{C}$			0.1	uA
Serial Data Clock Frequency	$f_{SCLK}$	I <sup>2</sup> C protocol, pull-up resistor of 10k			400	kHz
Digital Input High Voltage	$V_{IH}$		0.8			$V_{DD}$
Digital Input Low Voltage	$V_{IL}$				0.2	$V_{DD}$
Digital Output High Voltage	$V_{OH}$	$I_O = 0.5\text{ mA}$	0.9			$V_{DD}$
Digital Output Low Voltage	$V_{OL}$	$I_O = 0.5\text{ mA}$			0.1	$V_{DD}$
Input Capacitance	$C_{IN}$				10	pF

\*OSR stands for Over Sampling Rate.

**Table 3: Pressure Output Characteristics**

Parameter	Symbol	Conditions	Min	Typ	Max	Unit
Pressure Measurement Range	$P_{FS}$	Calibration range	300		1200	mbar
Pressure Absolute Accuracy		700 to 1100 mbar from 0°C to 50°C	-1.5		+1.5	mbar
		700 to 1100 mbar from -20°C to 70°C	-3		+3	mbar
Pressure Relative Accuracy		700 to 1100 mbar at 25°C		±0.5		mbar
		From 0°C to 50°C, under		±1.5		mbar
Max Error with Power Supply		Power supply from 1.8V to 3.6V	-2		+2	mbar
Pressure Resolution of Output Data		OSR = 4096		0.01		mbar
Altimeter Resolution of Output Data		OSR = 4096		0.1		m

**Table 4: Temperature Output Characteristics**

Parameter	Symbol	Conditions	Min	Typ	Max	Unit
Operation Temperature Range	$T_{OP}$		-40	25	85	°C
Temperature Measurement Range	$T_{FS}$	Calibration range	-20		60	°C
Temperature Absolute Accuracy		25°C		±0.3	±0.5	°C
		-10°C to +70°C		±0.6	±1.0	°C
		-40°C to +85°C		±1.0	±0.3	°C
Max Error with Power Supply		Power supply from 1.8V to 3.6V			±0.5	°C
Temperature Resolution of Output Data		OSR = 256		0.01		°C

**Table 5: Absolute Maximum Rating**

Parameter	Symbol	Conditions	Min	Max	Unit
Overpressure	$P_{MAX}$			2	bar
Supply Voltage	$V_{DD}$		-0.3	3.6	V
Interface Voltage	$V_{IF}$		-0.3	$V_{DD}+0.3$	V
Operation Temperature Range	$T_{OP}$		-40	125	°C
Storage Temperature Range	$T_{STG}$		-50	150	°C
Maximum Soldering Temperature	$T_{MS}$	40 second maximum		250	°C
ESD Rating		Human body model	-2	+2	kV
Latch-up Current		At 85°C	-100	100	mA

Stresses above those listed as “absolute maximum ratings” may cause permanent damage to the device. This is a stress rating only and functional operation of the device under these conditions is not implied. Exposure to maximum rating conditions for extended periods may affect device reliability.

## 2. Function Descriptions

### General

The HP203B is a high precision barometer and altimeter that measures the pressure and the temperature by an internal 24-bit ADC and compensates them by a patented algorithm. The fully-compensated values can be read out via the I<sup>2</sup>C interface by external MCU. The uncompensated values can also be read out in case the user wants to perform their own data compensation. The devices can also compute the value of altitude according to the measured pressure and temperature.

Furthermore, the device allows the user to setup the temperature, pressure and altitude threshold values for various events. Once the device detects that a certain event has happened, a corresponding interrupt will be generated and sent to the external MCU. Also, multiple useful interrupt options are available to be used by the user.

### Automatic Power-up

Once the device detects a valid VDD is externally supplied, an internal Power-On-Reset (POR) is generated and the device will automatically enter the power-up initialization sequence. After that the device will enter the sleep state. Normally the entire power-up sequence consumes about 400 us.

The user can scan a DEV\_RDY bit in the INT\_SRC register in order to know whether the device has finished its power-up sequence. This bit appears to 1 when the sequence is done. The device stays in the sleep state unless it receives a proper command from the external MCU. This will help to achieve minimum power consumptions.

### Sensor Output Conversion

For each pressure measurement, the temperature is always being measured prior to pressure measurement automatically, while the temperature measurement can be done individually. The conversion results are stored into the embedded memories that retain their contents when the device is in the sleep state.

The conversion time depends on the value of the OSR parameter sent to the device within the ADC\_CVT command. Six options of the OSR can be chosen, range from 128, 256 ... to 4096. The below table shows the conversion time according to the different values of OSR:

**Table 6: Conversion Time VS OSR**

OSR	Conversion Time (ms)	
	Temperature	Temperature and Pressure (or Altitude)
128	2.1	4.1
256	4.1	8.2
512	8.2	16.4
1024	16.4	32.8
2048	32.8	65.6
4096	65.6	131.1

The higher OSR will normally achieve higher measuring precision, but consume more time and power. The conversion results can be compensated or uncompensated. The user can enable/disable the compensation by setting the PARA register before performing the conversions.

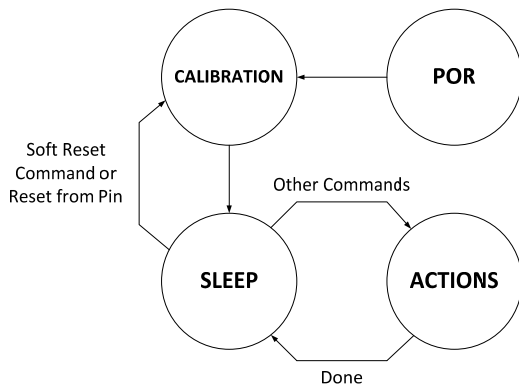
### Altitude Computation

The device can compute the altitude according to the measured pressure and temperature. The altitude value is updated and available to read as soon as the temperature and pressure measurement is done.

## 3. Access Modes & Commands

### Operation Flow

During each power-up/reset cycle, the device will only perform one calibration. After that it will enter the SLEEP state waiting for any incoming commands. It will take actions after receiving different proper commands, and re-enters the SLEEP state when it finishes the jobs.



### Command Set

The Command Set (Table 7) allows the user to control the device to perform the measuring, results reading and the miscellaneous normal operations.

#### SOFT\_RST (0x06)

Once the user issues this command, the device will immediately be reset no matter what it is working on. Once the command is received and executed, all the memories (except the NVM) will be reset to their default values following by a complete power-up sequence to be automatically performed.

#### ADC\_CVT (010, 3-bit OSR, 2-bit CHNL)

This command let the device to convert the sensor output to the digital values with or without compensation depends on the PARA register setting. The 2-bit channel (CHNL) parameter tells the device the data from which channel(s) shall be converted by the internal ADC. The options are shown below:

- 00: sensor pressure and temperature channel
- 10: temperature channel

The 3-bit OSR defines the decimation rate of the internal digital filter as shown below:

- |      |            |      |           |
|------|------------|------|-----------|
| 000: | OSR = 4096 | 011: | OSR = 512 |
| 001: | OSR = 2048 | 100: | OSR = 256 |
| 010: | OSR = 1024 | 101: | OSR = 128 |

Setting the CHNL bits to the value of 01 or 11, or the OSR bits to the values of 110 or 111 will lead to failure of conversion.

#### READ\_PT (0x10)

This command allows the user to read out the 24-bit temperature conversion result and 24-bit pressure conversion result in sequence, starting from the MSB of the temperature data and ending with the LSB of the pressure data.

#### READ\_AT (0x11)

This command allows the user to read out the 24-bit temperature conversion result and 24-bit altitude conversion result in sequence, starting from the MSB of the temperature data and ending with the LSB of the altitude data.

#### READ\_P (0x30)

This command allows the user to read out the 24-bit pressure conversion result, starting from the MSB.

### READ\_A (0x31)

This command allows the user to read out the 24-bit altitude conversion result, starting from the MSB.

**Example:** OSR = 256, CHNL = 10, the ADC conversion command code is 0x52.

### READ\_T (0x32)

This command allows the user to read out the 24-bit temperature conversion result, starting from the MSB.

### ANA\_CAL (0x28)

This command allows the user to re-calibrate the internal circuitries in a shorter time compare to soft resetting the device. It is designed for the applications where the device needs to work in a rapidly changed environment. In those environments, since the temperature and supply voltage may have changed significantly since the first power-up sequence during which the calibrations have been performed, the circuitries may not adept to the world as better as they were just calibrated. Therefore, in this case, re-calibrating the circuitries before performing any sensor conversions can give a more accurate result. Once the device received this command, it calibrates all the circuitries and enters the sleep state when it finishes. The user can simply send this command to the device before sending the ADC\_CVT command. However, it is not necessary to use this command when the environment is stable.

### READ\_REG (10, 6-bit register address)

This command allows the user to read out the control registers.

### WRITE\_REG (11, 6-bit register address)

This command allows the user to write in the control registers.

**Table 7: The Command Set**

Name	Hex Code	Binary Code	Descriptions
SOFT_RST	0x06	0000 0110	Soft reset the device
ADC_CVT	NA	010_OSR_chnl	Perform ADC conversion
READ_PT	0x10	0001 0000	Read the temperature and pressure values
READ_AT	0x11	0001 0001	Read the temperature and altitude values
READ_P	0x30	0011 0000	Read the pressure value only
READ_A	0x31	0011 0001	Read the altitude value only
READ_T	0x32	0011 0010	Read the temperature value only
ANA_CAL	0x28	0010 1000	Re-calibrate the internal analog blocks
READ_REG	NA	10_addr	Read out the control registers
WRITE_REG	NA	11_addr	Write in the control registers



## 4. The I<sup>2</sup>C Interface

The I<sup>2</sup>C interface is fully compatible to the official I<sup>2</sup>C protocol specification. All the data are sent starting from the MSB. Successful communication between the host and the device via the I<sup>2</sup>C bus can be done using the four types of protocol introduced below.

### The 1<sup>st</sup> TYPE: the host issuing a single byte command to the device

The host shall issue the Device Address (ID) followed by a Write Bit before sending a Command byte. The device will reply an ACK after it received a correct SOFT\_RST command.

	1	1	1	0	1	1	/CSB	0	0	0	0	0	0	0	1	1	0	0	
S	Device Address							W	A	Command							A	P	

### The 2<sup>nd</sup> TYPE: the host writing a register inside the device

The host shall issue the Device Address (ID) followed by a Write Bit before sending a command byte and a data byte. This format only applies while the user wants to send the WRITE\_REG command.

	1	1	1	0	1	1	/CSB	0	0	1	1	0	0	1	0	1	0	0	0	0	0	0	1	1	0	0	
S	Device Address							W	A	Command							A	Data							A	P	

### The 3<sup>rd</sup> TYPE: the host reading a register from the device

In this activity there are two frames that are sent separately. The first frame is to send the READ\_REG command which contains a 2-bit binary number of 10 followed by a 6-bit register address. The format of the first frame is identical to the 1<sup>st</sup> type activity. In the second frame, the device will send back the register data after receiving the correct Device Address followed by a Read Bit. This format only applies while the user wants to use the READ\_REG command.

	1	1	1	0	1	1	/CSB	0	0	1	0	0	0	0	1	1	0	0	
S	Device Address							W	A	Command							A	P	

	1	1	1	0	1	1	/CSB	1	0	1	0	0	1	0	1	1	0	1	
S	Device Address							R	A	Data							N	P	

### The 4th TYPE: the host reading the 3-byte or 6-byte ADC data from the device

In this activity there are two frames that are sent separately. The first frame is identical to sending a single command, which can be one of the conversion result reading commands. In the second frame, the device will send back the ADC data (either 3 bytes or 6 bytes depending on the commands) after receiving the correct Device Address followed by a Read Bit.

	1	1	1	0	1	1	/CSB	0	0	0	0	0	0	0	1	1	0	0	
S	Device Address							W	A	Command							A	P	

	1	1	1	0	1	1	//CSB	1	0	0	1	0	0	0	1	1	0	0	
S	Device Address							R	A	Data Byte 6 or 3							A		
									0	0	1	1	0	1	0	0	0	1	
									Data Byte 0							N	P		

### Bit Descriptions

- From Host     From Chip
- S Start Bit     P Stop Bit
- W Write     R Read
- A ACK     N NACK
- CSB Sensor CSB PIN

Note: The LSB of the Device Address is determined by the status of the CSB pin. For example, if the CSB pin is connected to VDD, the user should send logic 0 in the LSB.

**CSB PIN=0, device address with 'W' are 0xEE; CSB PIN=1 device address with 'W' are 0xEC**

## 5. Control Registers

The control registers allow the user to set the threshold values for various event detections, configure the interrupt setting, and enable/disable the data compensation. It is recommended for the user to set these registers to the desired values before performing the conversions or any other command-based operations. The following is a table of all the control registers.

The registers from 0x00 to 0x0A are designed for the user to setup the parameters (offset and thresholds) for pressure (or altitude) and temperature event detections. The registers from 0x0B to 0x0D are used for interrupt controls. The register of 0x0E is dedicated for switching on/off the sensor output compensation function inside the device.

**Table 9: Control Registers List**

Addr	Name	Default	Bit 7	Bit 6	Bit 5	Bit 4	Bit 3	Bit 2	Bit 1	Bit 0
0x00	ALT_OFF_LSB	0x00	ALT_OFF [7:0]							
0x01	ALT_OFF_MSB	0x00	ALT_OFF [15:8]							
0x02	PA_H_TH_LSB	0x00	PA_H_TH [7:0]							
0x03	PA_H_TH_MSB	0x00	PA_H_TH [15:8]							
0x04	PA_M_TH_LSB	0x00	PA_M_TH [7:0]							
0x05	PA_M_TH_MSB	0x00	PA_M_TH [15:8]							
0x06	PA_L_TH_LSB	0x00	PA_L_TH [7:0]							
0x07	PA_L_TH_MSB	0x00	PA_L_TH [15:8]							
0x08	T_H_TH	0x00	T_H_TH [7:0]							
0x09	T_M_TH	0x00	T_M_TH [7:0]							
0x0A	T_L_TH	0x00	T_L_TH [7:0]							
0x0B	INT_EN	0x00	Reserved	Reserved	PA_RDY_EN	T_RDY_EN	PA_TRAV_EN	T_TRAV_EN	PA_WIN_EN	T_WIN_EN
0x0C	INT_CFG	0x00	Reserved	PA_MODE	PA_RDY_CFG	T_RDY_CFG	PA_TRAV_CFG	T_TRAV_CFG	PA_WIN_CFG	T_WIN_CFG
0x0D	INT_SRC	0x00	TH_ERR	DEV_RDY	PA_RDY	T_RDY	PA_TRAV	T_TRAV	PA_WIN	T_WIN
0x0E	INT_DIR	0x00	CMPS_EN	Reserved	Reserved	Reserved	P_TRAV_DIR	T_TRAV_DIR	P_WIN_DIR	T_WIN_DIR
0x0F	PARA	0x80	CMPS_EN	Reserved	Reserved	Reserved	Reserved	Reserved	Reserved	Reserved

## Setup the Altitude Offset Compensation Parameter

### ALT\_OFF\_LSB, ALT\_OFF\_MSB - (RW)

The two registers form the 16-bit value of ALT\_OFF, which saves the altitude offset data used to compensate the altitude calculation. The data is in 2's complement format and the unit is in centimeter. The users need to set these registers if they need to use the altitude computation function of the device.

Normally, the values of the local average standard atmospheric pressure ( $P_{local}$ ) may vary in different places around the world. The varying range is from 1000 mbar to 1026 mbar. The device requires the user to setup the ALT\_OFF to remove the offset. The following table is provided to assist in finding the value of desired altitude offset.

$P_{local}$  has unit in mbar,  $A_{offset}$  has unit in meter

$P_{local}$	<b>1000</b>	<b>1001</b>	<b>1002</b>	<b>1003</b>
$A_{offset}$	-111.18	-102.73	-94.29	-85.85
$P_{local}$	<b>1004</b>	<b>1005</b>	<b>1006</b>	<b>1007</b>
$A_{offset}$	-77.43	-69.02	-60.62	-52.23
$P_{local}$	<b>1008</b>	<b>1009</b>	<b>1010</b>	<b>1011</b>
$A_{offset}$	-43.84	-35.47	-27.11	-18.76
$P_{local}$	<b>1012</b>	<b>1013</b>	<b>1014</b>	<b>1015</b>
$A_{offset}$	-10.41	-2.08	6.24	14.56
$P_{local}$	<b>1016</b>	<b>1017</b>	<b>1018</b>	<b>1019</b>
$A_{offset}$	22.86	31.15	39.44	47.71
$P_{local}$	<b>1020</b>	<b>1021</b>	<b>1022</b>	<b>1023</b>
$A_{offset}$	55.98	64.23	72.48	80.71
$P_{local}$	<b>1024</b>	<b>1025</b>	<b>1026</b>	
$A_{offset}$	88.94	97.16	105.36	

If the users find out that the value of  $P_{local}$  is an integer, they can directly obtain the corresponding altitude offset value in the above table; if the  $P_{local}$  has decimal numbers and the value is larger than  $P_1$  and smaller than  $P_2$  ( $P_1$  and  $P_2$  are two adjacent pressure values in the table), the user shall first obtain the corresponding altitude offset value  $A_1$  and  $A_2$  in the table, then use either of the following two formulas to calculate the desired altitude offset value  $A$ :

$$A = A_1 + 8.326 \times (P_{local} - P_1), \text{ or } A = A_2 - 8.326 \times (P_2 - P_{local})$$

For example, the  $P_{local}$  is 1016.4 mbar, which is between 1016 mbar ( $P_1$ ) and 1017 mbar ( $P_2$ ). Looking up the table,  $A_1$  is 22.86 m and  $A_2$  is 31.15 m. Thus:

$$A = 22.86 + 8.326 \times (1016.4 - 1016) = 26.19 \text{ m, or } A = 31.15 - 8.326 \times (1017 - 1016.4) = 26.15 \text{ m}$$

Either of the results is acceptable. After obtaining the value of  $A$ , no matter by looking up the table directly or by calculation, the user shall multiply the  $A$  by 100 in order to convert the unit from meter to centimeter.

Finally, convert the result to a 2's complement number to obtain ALT\_OFF, and fill it into the two registers. The following table shows 2 examples with the calculated altitude offsets and their corresponding values to fill into the two registers.

### Example:

Offset	Hex Value	ALT_OFF_MSB	ALT_OFF_LSB
50.02 m	0x138A	0x13	0x8A
-100.05 m	0XD8EB	0xD8	0xEB

## Setup the Events Detection Parameters

### PA\_H\_TH\_LSB, PA\_H\_TH\_MSB - (RW)

The two registers form the 16-bit value of PA\_H\_TH which saves the pressure (or altitude) upper bound threshold for event detection. When the PA\_MODE bit in the INT\_CFG register is set to 0, the contents stored in these registers are the pressure thresholds. Its value should be a 16-bit unsigned number and its unit is in 0.02 mbar. When setting the pressure thresholds, the user must divide the actual thresholds by 0.02, and then convert the result to a 2's complement number. When the PA\_MODE bit is set to 1, the contents stored in these registers are the altitude thresholds. Its value should be a 16-bit 2's complement number and its unit is in meter.

#### Example:

PA_MODE = 0 (pressure, unit in 0.02 mbar)			
Threshold	Hex Value	PA_H_TH_MSB	PA_H_TH_LSB
800.06 mbar	0x9C43	0x9C	0x43
900 mbar	0xAFC8	0xAF	0xC8
PA_MODE = 1 (altitude, unit in meter)			
Threshold	Hex Value	PA_H_TH_MSB	PA_H_TH_LSB
5000 m	0x1388	0x13	0x88

These examples are also applied to setting the pressure (or altitude) middle and lower bound threshold registers as introduced below.

### PA\_M\_TH\_LSB, PA\_M\_TH\_MSB - (RW)

The two registers form the 16-bit value of PA\_M\_TH which saves the pressure (or altitude) middle threshold for event detection. Similar to the PA\_H\_TH, the meaning of their values and the data formats are selected by the PA\_MODE bit.

### PA\_L\_TH\_LSB, PA\_L\_TH\_MSB - (RW)

The two registers form the 16-bit value of PA\_L\_TH which saves the pressure (or altitude) lower bound threshold for event detection. Similar to the PA\_H\_TH, the meaning of their values and the data formats are selected by the PA\_MODE bit.

### T\_H\_TH - (RW)

This register stores the 8-bit temperature threshold for event detection. The data is in 2's complement format and the unit is in °C.

#### Example:

Threshold	Hex Value	T_H_TH
45°C	0x2D	0x2D
-20°C	0xEC	0xEC

These examples are also applied for setting the temperature middle and lower bound threshold registers as introduced below.

### T\_M\_TH - (RW)

This register stores the 8-bit temperature middle threshold for event detection. The data is in 2's complement format and the unit is in °C.

### T\_L\_TH - (RW)

This register stores the 8-bit temperature lower bound threshold for event detection. The data is in 2's complement format and the unit is in °C.

### Improper Setting Of Thresholds

Improperly setting the thresholds, such as setting the lower bound threshold to be larger than the upper bound threshold, will lead to unexpected behavior of the device. It is recommended for the user to check the status of the TH\_ERR bit in the INT\_SRC register after setting the thresholds into the device. Logic 1 of this bit indicates that improper setting of the thresholds occurs.

## Configure the Interrupts

There are 6 interrupts that can be generated by the device. They are:

### PA\_RDY

Indicates that the pressure (or altitude) measurement is done and the result is ready to read.

### T\_RDY

Indicate that the temperature measurement is done and the result is ready to read.

### PA\_TRAV

Indicate that the pressure (or altitude) value has traversed the middle threshold during the last measurement.

### T\_TRAV

Indicate that the temperature value has traversed the middle threshold during the last measurement.

### PA\_WIN

Indicate that the pressure (or altitude) value locates outside the pre-defined window (the value in between the upper bound and lower bound thresholds) during the last measurement.

### T\_WIN

Indicate that the temperature value locates outside the pre-defined window (the value in between the upper bound and lower bound thresholds) during the last measurement.

The interrupt names prefixed by a 'PA' relate to the pressure (or altitude) measurement. The interrupt names prefixed by a 'T' relate to the temperature measurement. These interrupts are all active-high and will remain high until the interrupt-clearing conditions happen. The interrupt-clearing conditions are that the device has received a new ADC result-reading command or a new ADC conversion command. There are three registers available for the interrupt controls as shown below.

### INT\_EN - (RW)

The INT\_EN register allows the user to disable/enable each of the 6 interrupts (0: disable, 1: enable). When the users need enable the traversal or window interrupt, they must also enable the corresponding PA\_RDY\_EN or T\_RDY\_EN bit.

### INT\_CFG - (RW)

The INT\_CFG register allows the user to select whether to output the interrupts from the INT1 pin (0: do not output, 1: output). The register also contains a control bit 'PA\_MODE' that selects whether the event detection parameters and the interrupts registers prefixed by a 'PA\_' corresponds to the pressure or the altitude measurement (0: pressure, 1: altitude).

### INT\_SRC - (Read-only)

The INT\_SRC register contains the interrupt flags that allow the user to know the interrupts status, as well as a device status bit 'DEV\_RDY' that tells whether the device is ready for access or not. The device is ready when it is in the sleep state and is not performing the power-up sequence, the data conversions, and any other command-based operations. The external MCU shall only access to the device while the device is ready (DEV\_RDY = 1).

If the INT\_CFG bit is set to 0 while the INT\_EN bit is set to 1, the corresponding interrupt flag will appear in the INT\_SRC register but the interrupt will not be output to the INT1 pin.

### INT\_DIR - (Read-only)

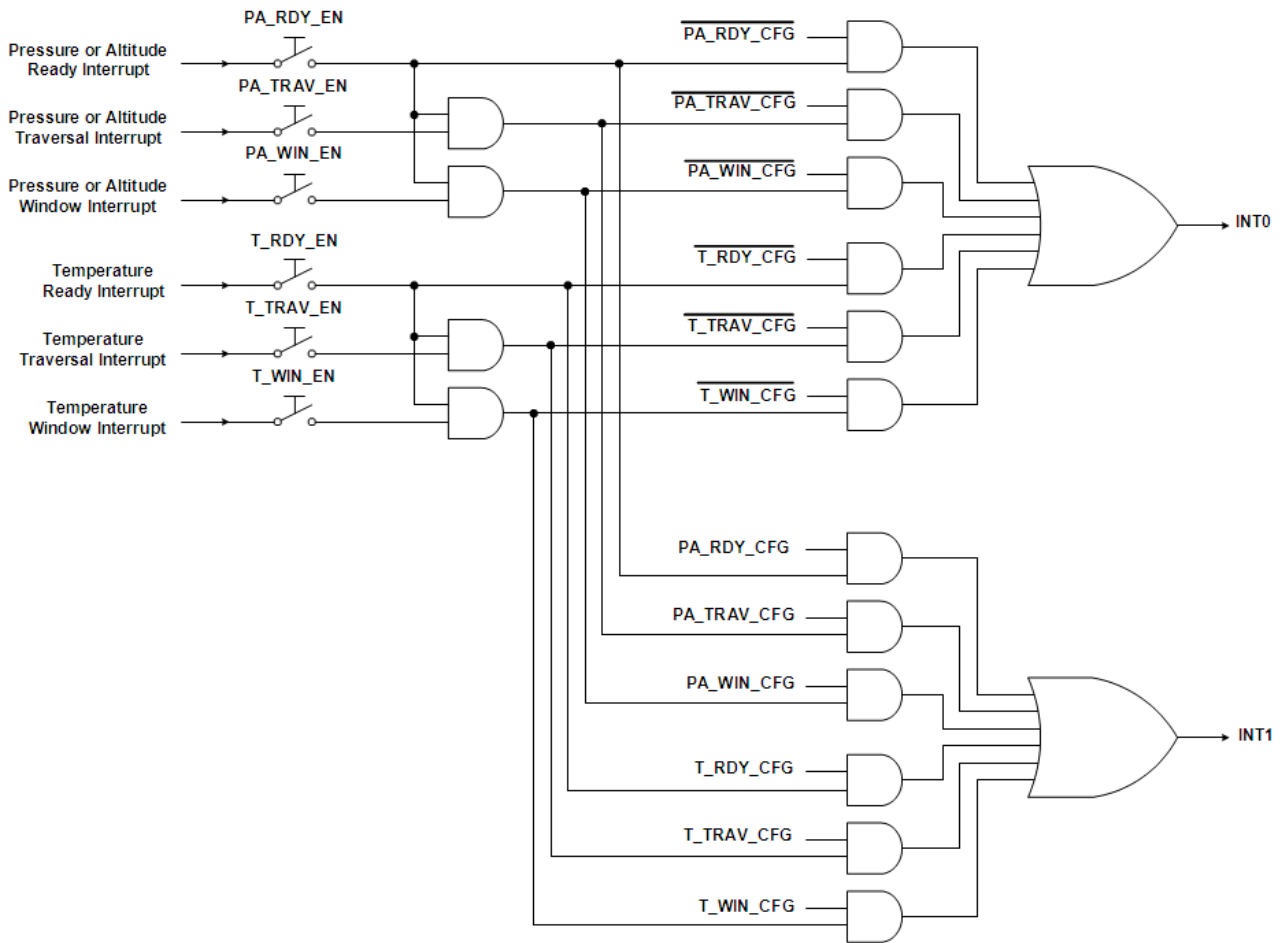
The INT\_DIR register allows the user to check the details of the traversal or window interrupt events.

For the T\_WIN\_DIR and the P\_WIN\_DIR status bits, when the window interrupts happen, if the temperature or pressure value is above the window, the corresponding status bit is read as 1; if the value is below the window, the status bit is read as 0.

For the T\_TRAV\_DIR and the P\_TRAV\_DIR status bits, when the traversal interrupts happen, if the temperature, pressure or altitude value has been rising from low to high, the corresponding status bit is read as 1; if the value has been falling from high to low, the status bit is read as 0.

Figure 2 shows how the 6 interrupts sources are controlled and mapped to the 2 interrupt output pins. It can be seen that, the "traversal" and "window" interrupts can only be set high while the corresponding "ready" interrupts are enabled and set high.

On the other hand, the status of the TH\_ERR, DEV\_RDY and the four INT\_DIR bits are only readable via registers without interrupt signals output to the pins.



**Figure 2: Interrupts mapping diagram**

**INTERRUPTS GENERATION**

The relationship between the conversion and interrupts generation are shown in the Figure 4.

The T related interrupts are generated as soon as the temperature conversion is finished. This means that once the external MCU detect the T interrupts, the temperature conversion result is valid to read.

The PA related interrupts are generated as soon as the pressure conversion is finished. This means that once the external MCU detect the PA interrupts, the pressure conversion result is valid to read.

However, an additional 5 us is required to compute the altitude based on the temperature and pressure conversion results. Therefore, after detecting the PA interrupts, the MCU must wait another 5 us before reading the A computation result.

**INTERRUPTS CLEARING**

The relationship between the commands and the interrupts clearing are shown in the Figure 4.

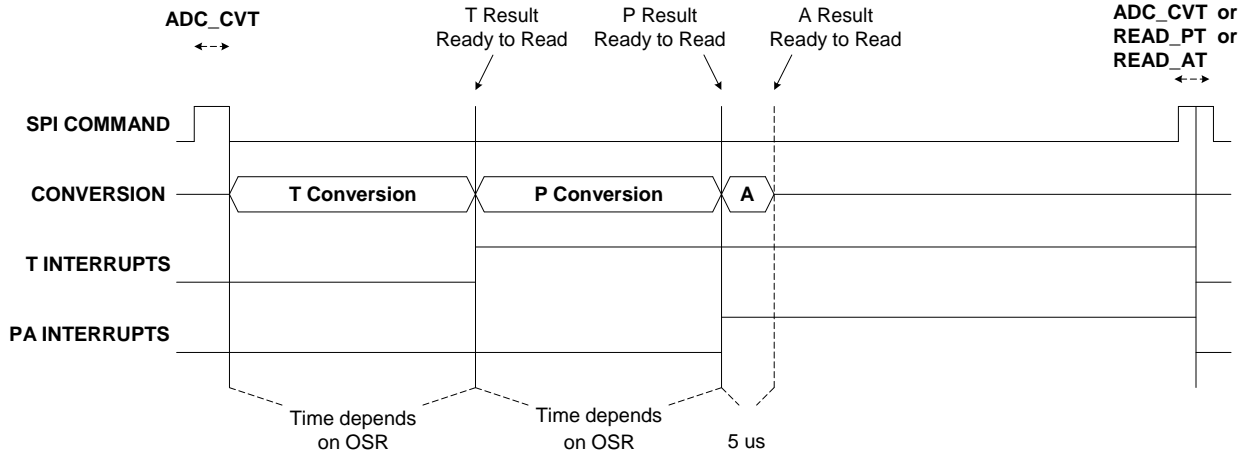
The ADC\_CVT, READ\_PT or READ\_AT command will clear the T\_RDY and PA\_RDY interrupts. As shown in Figure 3, once the “RDY” interrupt is cleared, the “WIN” and “TRAV” interrupts will be cleared at the same time. However, the “WIN”, “TRAV” and “DIR” register bits will remain their values until a new conversion is done.

The READ\_P or READ\_A command will only clear the PA\_RDY interrupt. The T related interrupt and register bits will not be changed by these 2 commands.

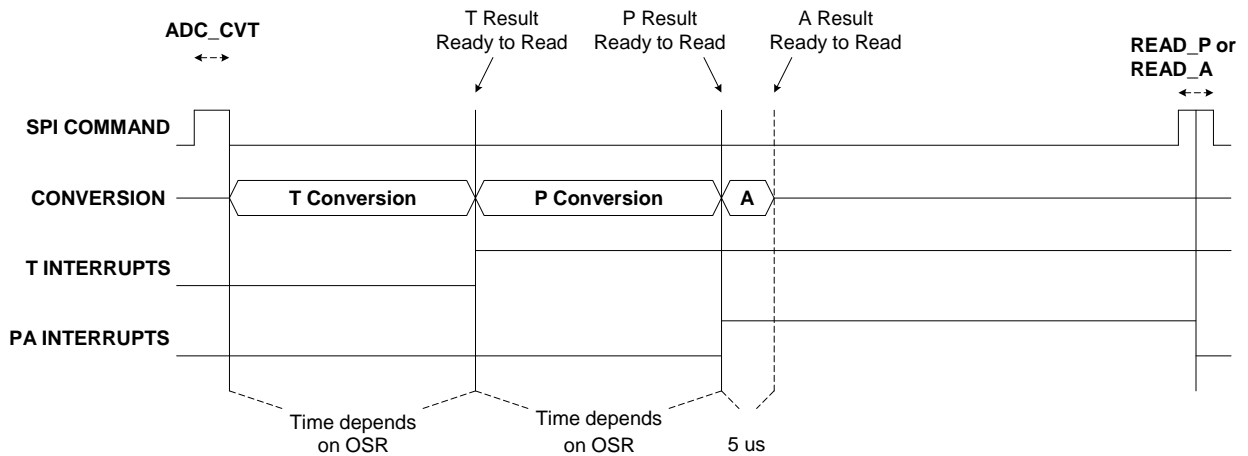
The READ\_T command will only clear the T\_RDY interrupt. The PA related interrupt and register bits will not be changed by this command.

The **SOFT\_RST** will clear all the interrupts as well as the related register bits.

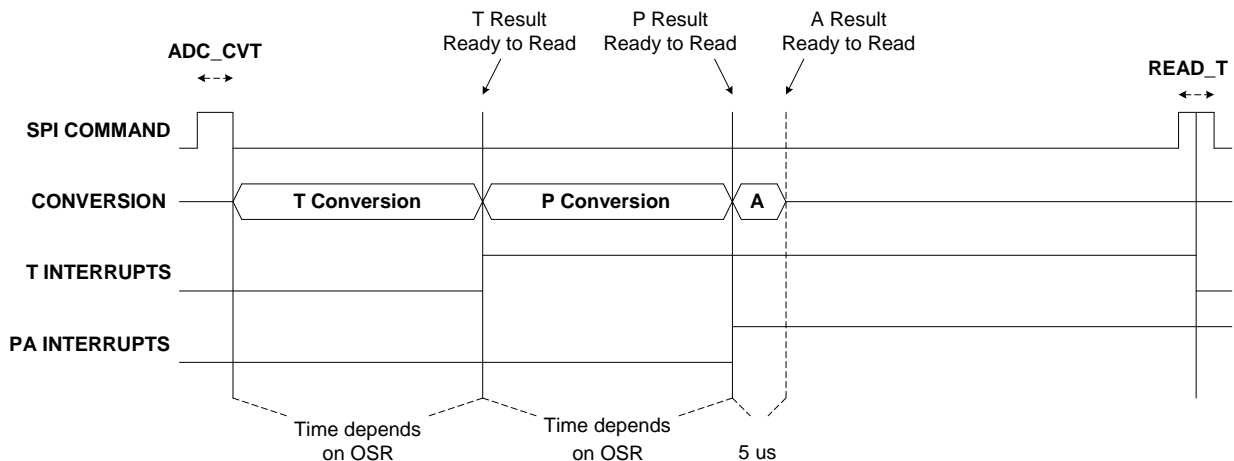
As shown in the Figure 3, the interrupts are cleared once the device has confirmed a valid command is received. However, this does not necessarily mean that an interrupt must go low after a command is fully transmitted. For example, while an interrupt is being cleared by an ADC reading command, it goes low while the data is being sent back from the device to the external MCU.



**Figure 3(a): Timing of T and P conversion and clearing the T and P interrupts**

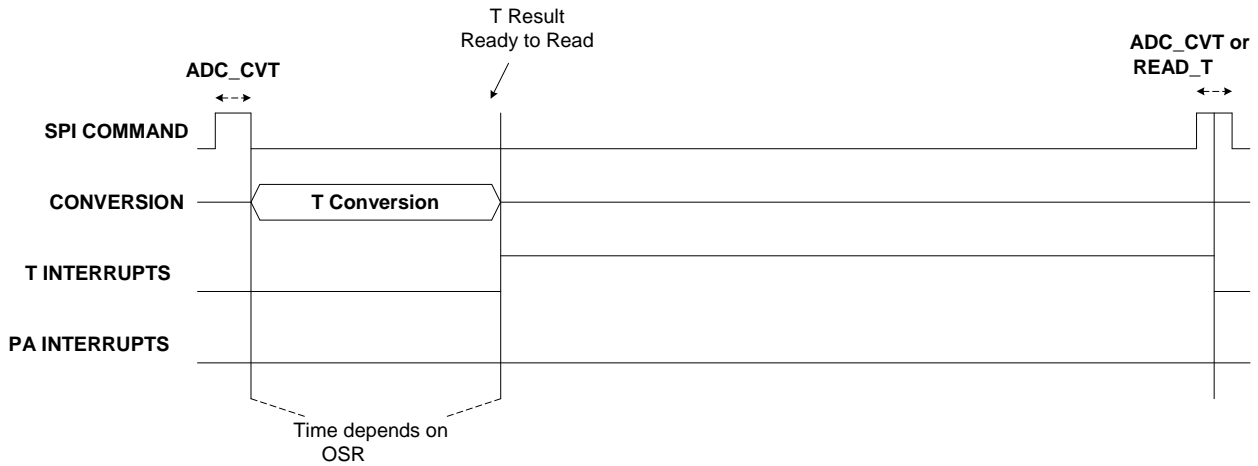


**Figure 3(b): Timing of T and P conversion and clearing the P interrupt**



**Figure 3(c): Timing of T and P conversion and clearing the T interrupt**





**Figure 3(d): Timing of T conversion and clearing the T interrupt**

### Enable the Compensation

#### PARA - (RW)

This register has only one valid bit of CMPS\_EN. The user can use this bit to determine whether to enable the data compensation during the conversion process (0: disable, 1: enable). If it is enabled, the 24-bit or 48-bit data read out by the commands are fully compensated. If it is disabled, the data read out are the raw data output.

## 6. Typical Application Circuit

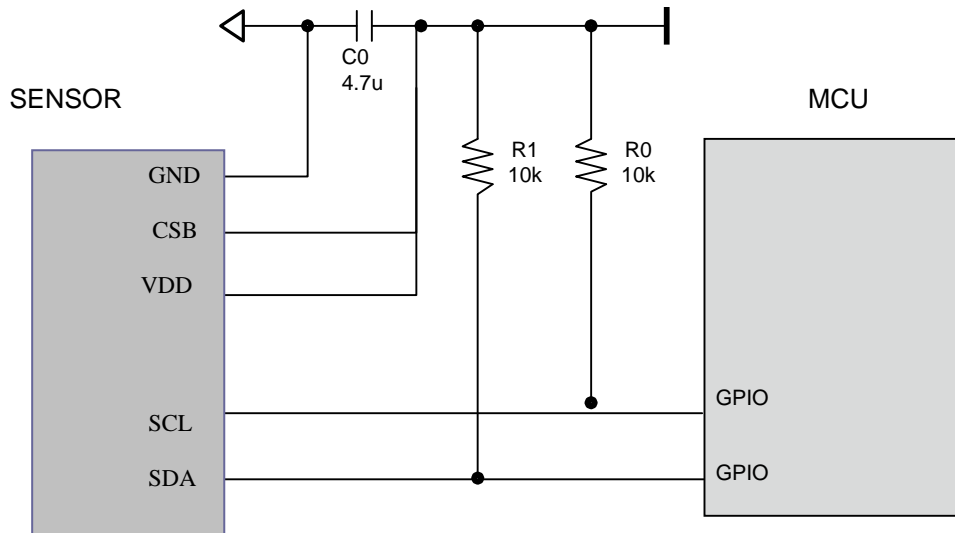


Figure4: Typical application circuit

## 7. Package Information

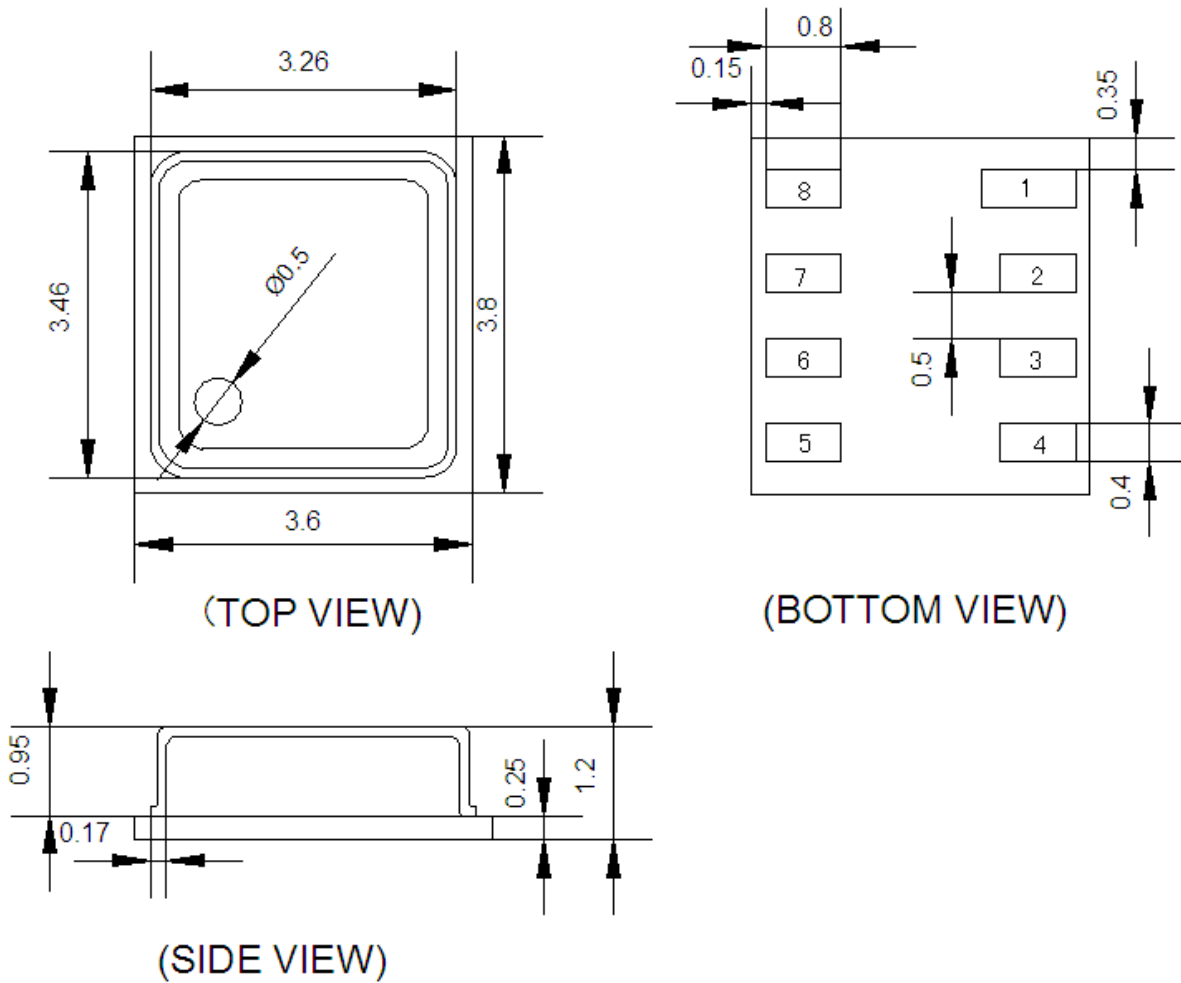


Figure5: HP203B package outline

**Notes:**

Mechanical dimension is mm  
General tolerance  $\pm 0.1$

**HOPE MICROELECTRONICS CO.,LTD**

Add: 2/F, Building 3, Pingshan Private  
Enterprise Science and Technology  
Park, Lishan Road, XiLi Town,  
Nanshan District, Shenzhen,  
Guangdong, China

Tel: +86 755 82973805

Fax: +86 755 82973550

Email: [sales@hoperf.com](mailto:sales@hoperf.com)

Website: <http://www.hoperf.com>

<http://www.hoperf.cn>

This document may contain preliminary information and is subject to change by Hope Microelectronics without notice. Hope Microelectronics assumes no responsibility or liability for any use of the information contained herein. Nothing in this document shall operate as an express or implied license or indemnity under the intellectual property rights of Hope Microelectronics or third parties. The products described in this document are not intended for use in implantation or other direct life support applications where malfunction may result in the direct physical harm or injury to persons. NO WARRANTIES OF ANY KIND, INCLUDING, BUT NOT LIMITED TO, THE IMPLIED WARRANTIES OF MERCHANTABILITY OR FITNESS FOR A PARTICULAR PURPOSE, ARE OFFERED IN THIS DOCUMENT.

©2013, HOPE MICROELECTRONICS CO.,LTD. All rights reserved.