



### General Description:

HPF650R057PF-G, the silicon N-channel Enhanced MOSFETs, is obtained by the super junction technology which reduces the conduction loss, improve switching performance and enhance the avalanche energy. The transistor can be used in various power switching circuit for system miniaturization and higher efficiency. The package type is TO-247, which accords with the RoHS standard.

### Features:

- | Fast Switching
- | Low Gate Charge
- | Low Reverse transfer capacitances
- | 100% Single Pulse avalanche energy Test
- | Halogen Free

### Applications:

PC、Server power.

$V_{DSS}(T_{jmax})$	700	V
$I_D$	50	A
$P_D(T_C=25^\circ C)$	400	W
$R_{DS(ON)Typ}$	52	m $\Omega$
$E_{oss@400V}$	8.7	uJ

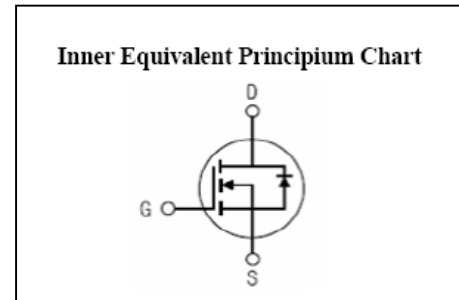
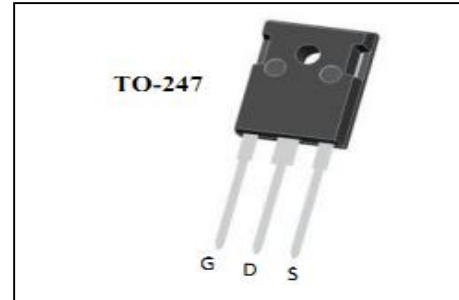

### Absolute ( $T_j=25^\circ C$ unless otherwise specified):

Symbol	Parameter	Rating	Units
$V_{DSS}$	Drain-to-Source Voltage( $V_{GS}=0V$ )	650	V
$I_D^{a1}$	Continuous Drain Current( $T_c=25^\circ C$ )	50	A
$I_{DM}^{a2}$	Pulsed Drain Current( $T_c=25^\circ C$ )	150	A
$V_{GSS}$	Gate-to-Source Voltage	$\pm 30$	V
$E_{AS}^{a3}$	Single Pulse Avalanche Energy	1300	mJ
$dv/dt^{a4}$	Peak Diode Recovery dv/dt	50	V/ns
dv/dt	MOSFET dv/dt ruggedness	100	V/ns
$di_f/dt$	Maximum diode communication speed	500	A/us
$P_D$	Power Dissipation( $T_c=25^\circ C$ )	400	W
$T_J, T_{stg}$	Operating and Storage Temperature Range	-55...+150	$^\circ C$
$T_L$	Maximum Temperature for Soldering	300	$^\circ C$

**Electrical Characteristics** ( $T_J = 25^\circ\text{C}$  unless otherwise specified):

<b>OFF Characteristics</b>						
Symbol	Parameter	Test Conditions	Rating			Units
			Min.	Typ.	Max.	
$V_{DSS}$	Drain to Source Breakdown Voltage	$V_{GS}=0V, I_D=250\mu A$	650	--	--	V
$\Delta BV_{DSS}/\Delta T_J$	Bvdss Temperature Coefficient	$ID=250\mu A, \text{Reference } 25^\circ\text{C}$	--	0.60	--	V/°C
$I_{DSS}$	Drain to Source Leakage Current	$V_{DS} = 650V, V_{GS} = 0V, T_J = 25^\circ\text{C}$	--	--	25	$\mu A$
		$V_{DS} = 520V, V_{GS} = 0V, T_J = 125^\circ\text{C}$	--	--	500	
$I_{GSS(F)}$	Gate to Source Forward Leakage	$V_{GS} = +30V, V_{DS} = 0V,$	--	--	100	nA
$I_{GSS(R)}$	Gate to Source Reverse Leakage	$V_{GS} = -30V, V_{DS} = 0V,$	--	--	-100	nA

<b>ON Characteristics</b>						
Symbol	Parameter	Test Conditions	Rating			Units
			Min.	Typ.	Max.	
$R_{DS(ON)}$	Drain-to-Source On-Resistance	$V_{GS}=10V, I_D=24.6A$	--	52	57	m $\Omega$
$V_{GS(TH)}$	Gate Threshold Voltage	$V_{DS} = V_{GS}, I_D = 250\mu A$	3	4	5	V
Pulse width $t_p \leq 300\mu s, \delta \leq 2\%$						

<b>Dynamic Characteristics</b>						
Symbol	Parameter	Test Conditions	Rating			Units
			Min.	Typ.	Max.	
$R_g$	Gate resistance	$f = 1.0\text{MHz}$	--	5.2	--	$\Omega$
$C_{iss}$	Input Capacitance	$V_{GS} = 0V, V_{DS} = 100V, f = 100\text{KHz}$	--	5535	--	pF
$C_{oss}$	Output Capacitance		--	158	--	
$C_{rss}$	Reverse Transfer Capacitance		--	2.0	--	

<b>Resistive Switching Characteristics</b>						
Symbol	Parameter	Test Conditions	Rating			Units
			Min.	Typ.	Max.	
$t_{d(ON)}$	Turn-on Delay Time	$I_D = 24.6A, V_{DD} = 400V, V_{GS} = 13V, R_G = 10\Omega$	--	38	--	ns
$t_r$	Rise Time		--	36	--	
$t_{d(OFF)}$	Turn-Off Delay Time		--	125	--	
$t_f$	Fall Time		--	8.6	--	
$Q_g$	Total Gate Charge	$I_D = 24.6A, V_{DD} = 400V, V_{GS} = 10V$	--	116	--	nC
$Q_{gs}$	Gate to Source Charge		--	31	--	
$Q_{gd}$	Gate to Drain ("Miller") Charge		--	45	--	
$V_{plateau}$	Gate Plateau Voltage		--	6.0	--	

Source-Drain Diode Characteristics						
Symbol	Parameter	Test Conditions	Rating			Units
			Min.	Typ.	Max.	
$I_S$	Continuous Source Current (Body Diode)	$T_C=25^\circ\text{C}$	--	--	50	A
$I_{SM}$	Maximum Pulsed Current (Body Diode)		--	--	150	A
$V_{SD}$	Diode Forward Voltage	$I_S=25\text{A}, V_{GS}=0\text{V}$	--	--	1.2	V
$T_{rr}$	Reverse Recovery Time	$I_S=24.6\text{A}, T_j = 25^\circ\text{C}$ $dI_F/dt=100\text{A}/\mu\text{s},$ $V_{GS}=0\text{V}$ $V_{dd}=400\text{V}$	--	125	--	ns
$Q_{rr}$	Reverse Recovery Charge		--	503	--	nC
$I_{rrm}$	Reverse Recovery Current		--	8	--	A

**Thermal Restistance**

Symbol	Parameter	Max.	Units
$R_{\theta JC}$	Junction-to-Case	0.31	$^\circ\text{C}/\text{W}$
$R_{\theta JA}$	Junction-to-Ambient	40	$^\circ\text{C}/\text{W}$

- <sup>a1</sup>: Limited by  $T_{jmax}$  Maximum duty cycle  $D=0.75$   
<sup>a2</sup>: Repetitive rating; pulse width limited by maximum junction temperature  
<sup>a3</sup>:  $L=20.0\text{mH}, R_g=25\ \Omega, V_{dd}=50\text{V}, \text{Start } T_j=25^\circ\text{C}$   
<sup>a4</sup>: identical low side and high side switch with identical  $R_g$

Characteristics Curve:

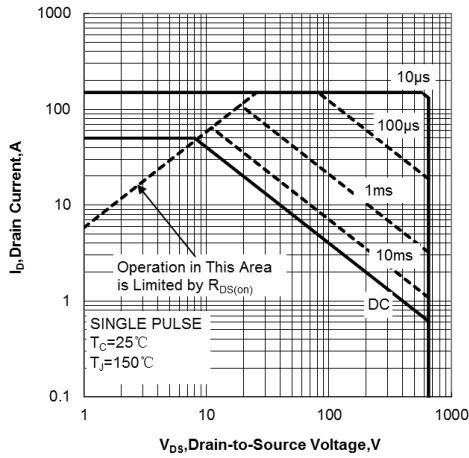

Figure.1 Maximum Forward Bias Safe Operating Area

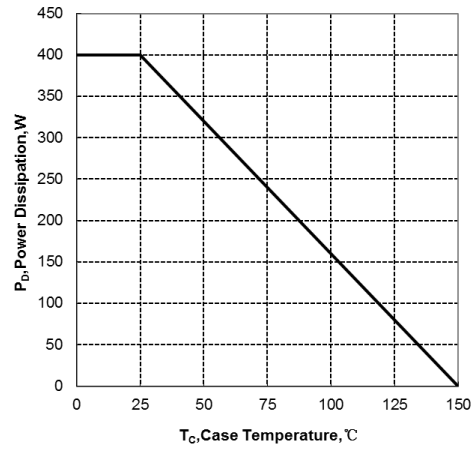

Figure.2 Maximum Power Dissipation vs Case Temperature

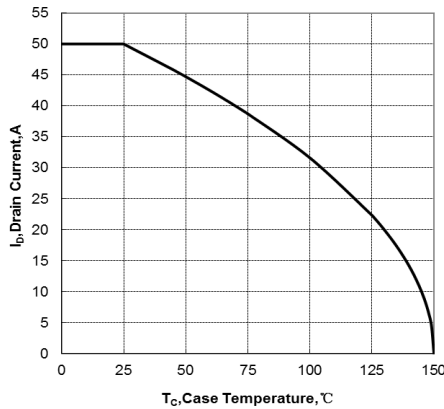

Figure.3 Maximum Continuous Drain Current vs Case Temperature

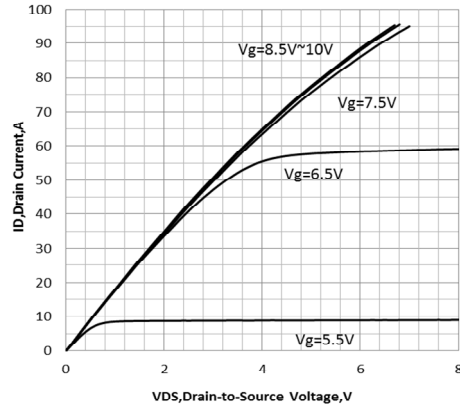

Figure.4 Typical Output Characteristics

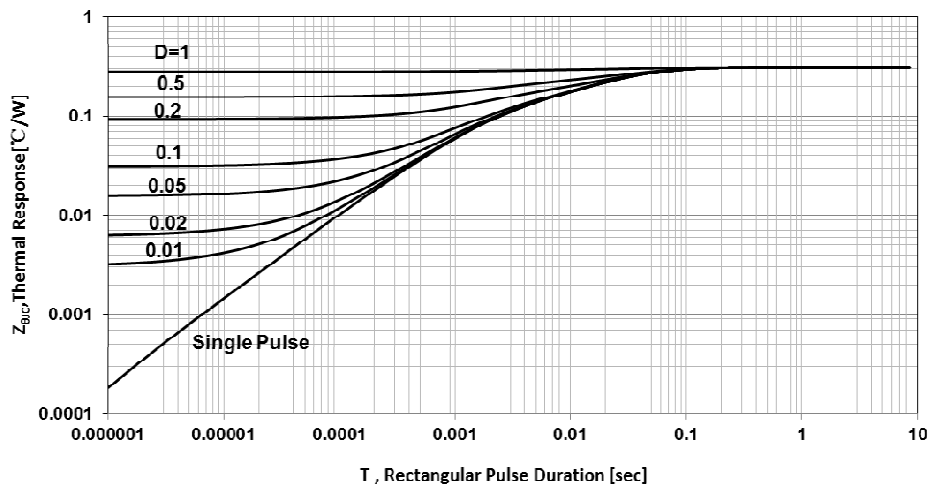

Figure.5 Maximum Effective Thermal Impedance , Junction to Case

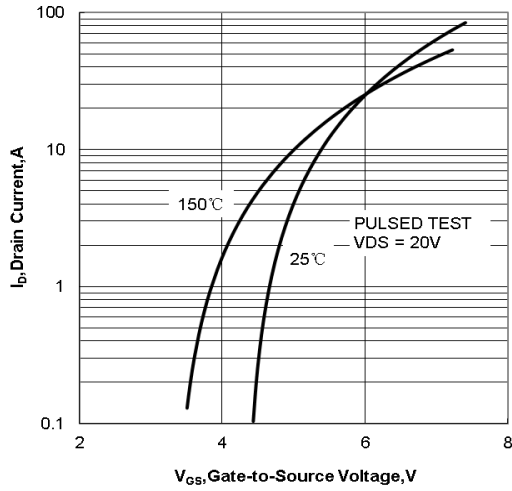

Figure.6 Typical Transfer Characteristics

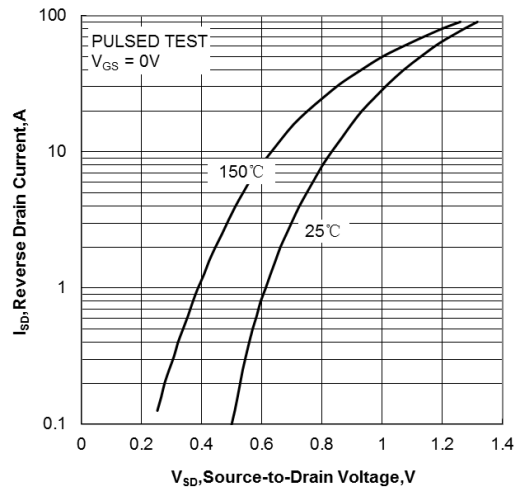

Figure.7 Typical Body Diode Transfer Characteristics

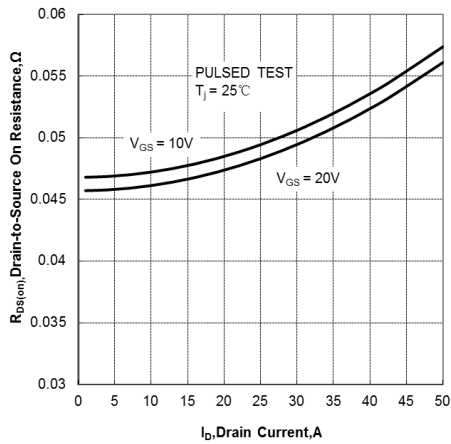

Figure.8 Typical Drain to Source ON Resistance vs Drain Current

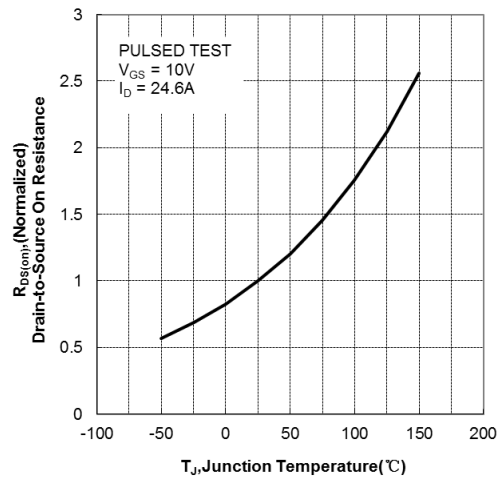

Figure.9 Typical Drain to Source on Resistance vs Junction Temperature

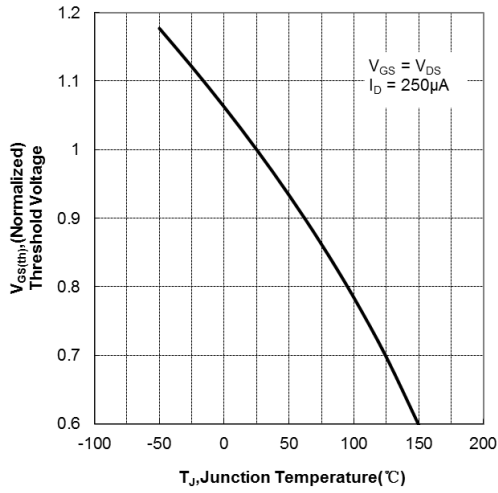

Figure.10 Typical Theshold Voltage vs Junction Temperatu

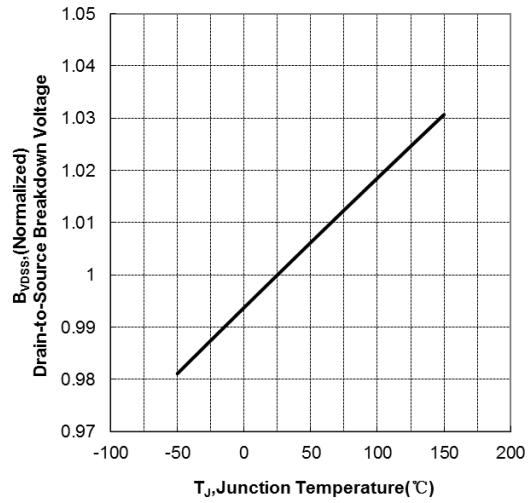

Figure 11 Typical Breakdown Voltage vs Junction Temperature

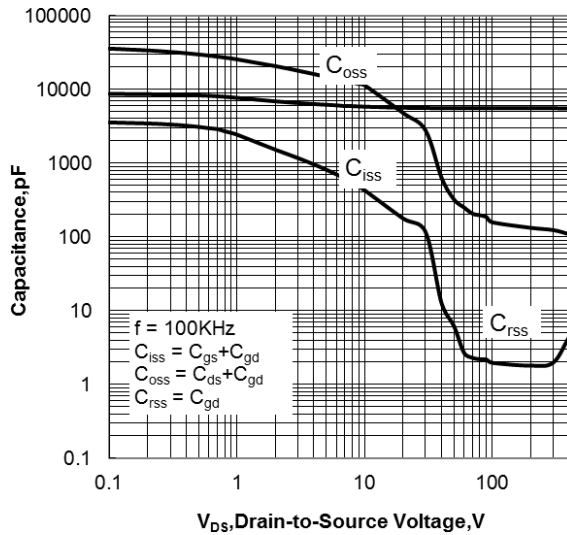

Figure.12 Typical Capacitance vs Drain to Source Voltage

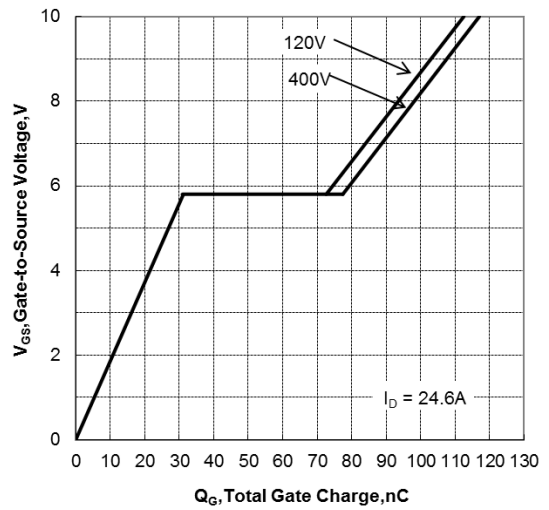

Figure.13 Typical Gate Charge vs Gate to Source Voltage

**Test Circuit and Waveform**

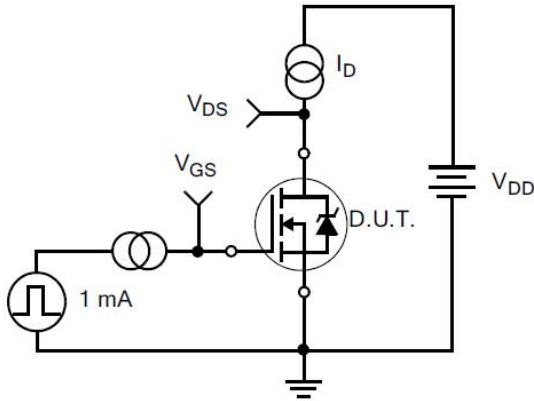

Figure 14. Gate Charge Test Circuit



Figure 15. Gate Charge Waveforms

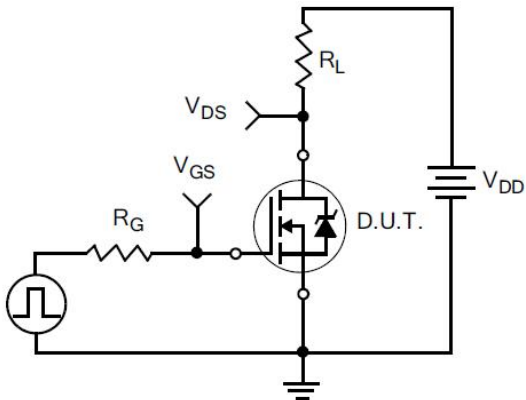

Figure 16. Resistive Switching Test Circuit



Figure 17. Resistive Switching Waveforms

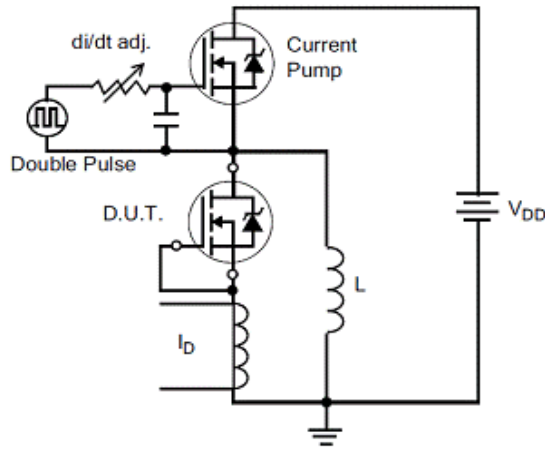

Figure 18. Diode Reverse Recovery Test Circuit

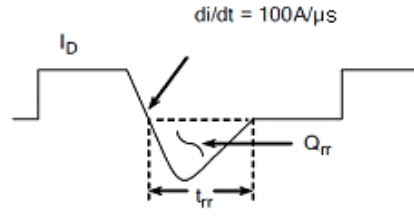

Figure 19. Diode Reverse Recovery Waveform



Figure20.Unclamped Inductive Switching Test Circuit

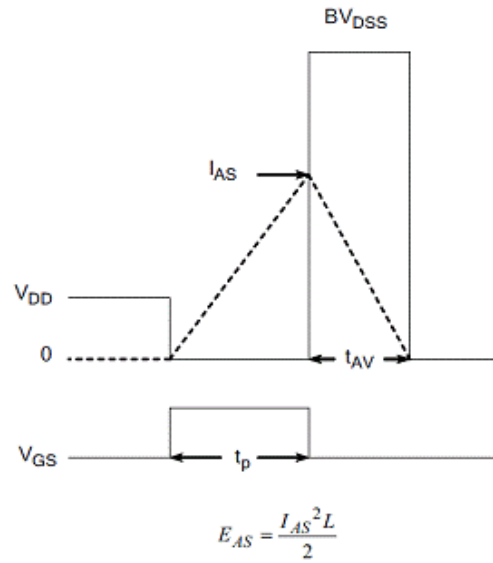
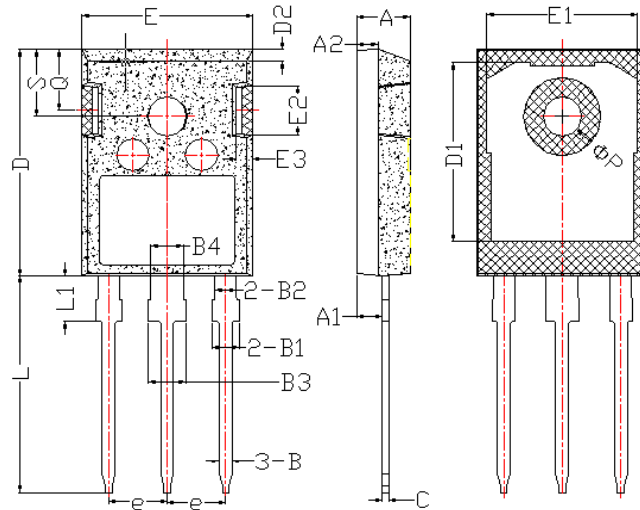

Figure21.Unclamped Inductive Switching Waveform



Package Information



项 目	规范(mm)	
	MIN	MAX
A	4.6	5.2
A1	2.2	2.6
B	0.9	1.4
B1	1.75	2.35
B2	1.75	2.15
B3	2.8	3.35
B4	2.8	3.15
C	0.5	0.7
D	20.60	21.30
D1	16	18
E	15.5	16.10
E1	13	14.7
E2	3.80	5.3
E3	0.8	2.60
e	5.2	5.7
L	19	20.5
L1	3.9	4.6
ΦP	3.3	3.70
Q	5.2	6.00
S	5.8	6.6

TO-247 Package

