

HPI - 6FH

The HPI - 6FH is a high - output, high - speed silicon photodiode mounted in a side - viewing plastic package . This photodiode is both compact and easy to mount.

FEATURES

- Plastic mold package
- High speed response

APPLICATIONS

- Optical pick up

DIMENSIONS

(Unit : mm)

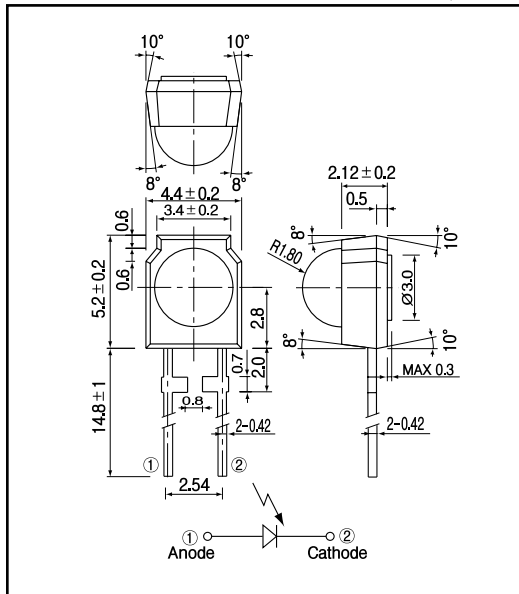

MAXIMUM RATINGS

(Ta=25)

Item	Symbol	Rating	Unit
Reverse voltage	V_R	30	V
Power dissipation	P_D	30	mW
Operating temp.	$T_{opr.}$	- 25 + 85	
Storage temp.	$T_{stg.}$	- 40 + 100	
Soldering temp.*1	$T_{sol.}$	260	

*1.For MAX.5 seconds at the position of 2 mm from the package

ELECTRO-OPTICAL CHARACTERISTICS

(Ta=25)

Item	Symbol	Conditions	Min.	Typ.	Max.	Unit.
Light current	I_L	$V_R=10V, E=1000lx^2$	25			μA
Sensitivity	S	$V_R=10V, p=780nm$	0.43	0.48		A/W
Dark current	I_d	$V_R=10V$			5.0	nA
Capacitance	C_t	$V_R=10V, f=1MHz$		3.0		pF
Spectral sensitivity				450-1050		nm
Peak wavelength	p			800		nm
Half angle				± 40		deg.
Rise time	t_r	$V_R=10V, R=1k$		10		ns
Fall time	t_f	$p=780 800nm$		10		ns

*2.Color temp.=2856K standard Tungsten lamp

PIN Photodiode

HPI - 6FH

Light current Vs. Forward voltage

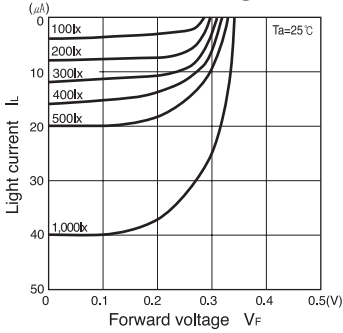

Short circuit current I_sc Vs. Illuminance Ev

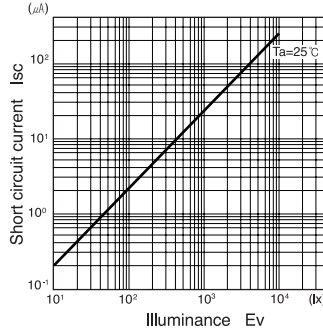

Dark current I_d Vs. Ambient temperature Ta

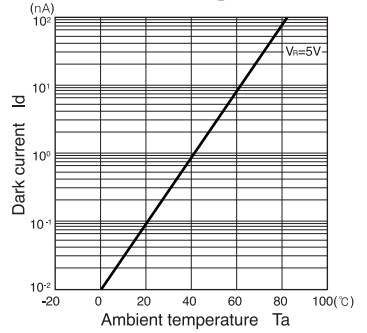

Relative sensitivity Vs. Wavelength

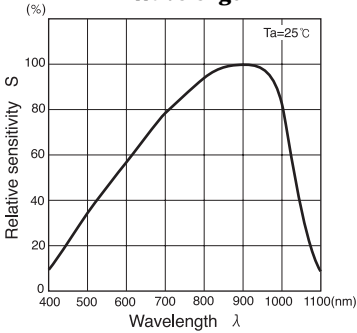

Dark current I_d Vs. Reverse voltage V_R

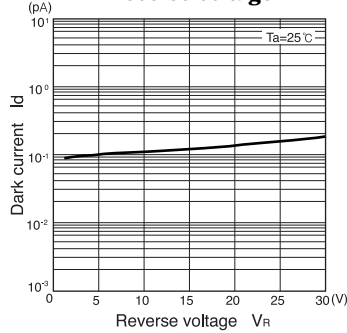

Radiant Pattern

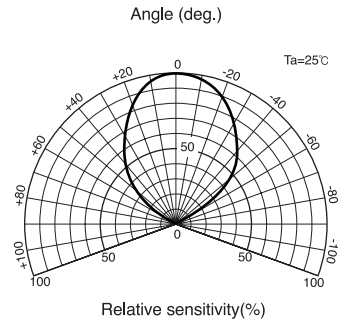

Capacitance between terminals Vs. Reverse voltage

