



The Future of Analog IC Technology®

HR1204

Digital PFC + LLC Combo Controller with Standby Power Input to VCC Programmable Noise Suppression Filter

DESCRIPTION

The HR1204 is a high-performance controller that integrates an advanced, digital, PFC controller and a half-bridge, LLC resonant controller. The HR1204 requires low input power at no-load or ultra-light load, making it compliant with the Energy Using Product Directive (EuP) Lot 6 and Code of Conduct Version 5 Tier 2 specifications.

The PFC of the HR1204 employs a patented average current control scheme, which can operate both in continuous conduction mode (CCM) and discontinuous conduction mode (DCM) according to the instantaneous condition of the input voltage and output load. The IC exhibits excellent efficiency and high power factor (PF) at light load. The performance of the PFC can be optimized by programming multiple parameters through an I²C GUI. Programming can be completed either by the factory or by the customer referring to a detailed user guide.

The half-bridge LLC resonant converter achieves high efficiency with zero-voltage switching (ZVS). The HR1204 implements an adaptive dead-time adjustment (ADTA) function to guarantee ZVS in different load conditions. Additionally, the HR1204 can prevent the LLC converter from operating in capacitive mode, making it more robust and easier to design.

In order to improve the noise immunity, HR1204 implements multiple programmable digital filters on critical signals.

Full protection features include thermal shutdown, open-loop protection (OLP), over-current protection (OCP), over-voltage protection (OVP), and brown-in/-out protection.

The HR1204 is suitable for standby power applications and is available in TSSOP28 and SOIC-28 packages.

FEATURES

General System Features

- Meets EuP Lot 6 and CoC Version 5 Tier 2 Specifications
- Standard I²C Interface
- 1k EEPROM to Store Parameters
- User-Friendly GUI for Digital PFC
- VCC Supplied by External DC Input from Additional Isolated Power Source

PFC Controller

- High Efficiency from Light Load to Full Load by CCM/DCM Multi-Mode Control
- High PF Due to Patented Input Capacitor Current Compensation
- Programmable Filter for Noise Suppression
- Programmable Frequency Jittering
- Programmable Brown-In and Brown-Out
- Programmable Soft Start
- Cycle-by-Cycle Current Limit
- Open-Loop Protection

LLC Controller

- 600V High-Side Gate Driver with Integrated Bootstrap Diode and High dV/dt Immunity
- Adaptive Dead-Time Adjustment of HB LLC with Minimum and Maximum Limit
- Burst Mode Switching
- Safe Start-Up in Case of System Fault
- Two-Level Over-Current Protection (OCP)
- Latch Shutdown Protection
- Over-Temperature Protection (OTP)
- Capacitive Mode Protection

APPLICATIONS

- Notebook Adapters
- All-in-One or Gaming Power Supply
- Desktop PC and ATX Power
- General AC/DC Power Supply up to 600W
- OLED and Large Format LCD TV Power Supply

MPS parts are lead-free, halogen-free, and adhere to the RoHS directive. For MPS green status, please visit the MPS website under quality assurance. "MPS" and "The Future of Analog IC Technology" are registered trademarks of Monolithic Power Systems, Inc.

TYPICAL APPLICATION

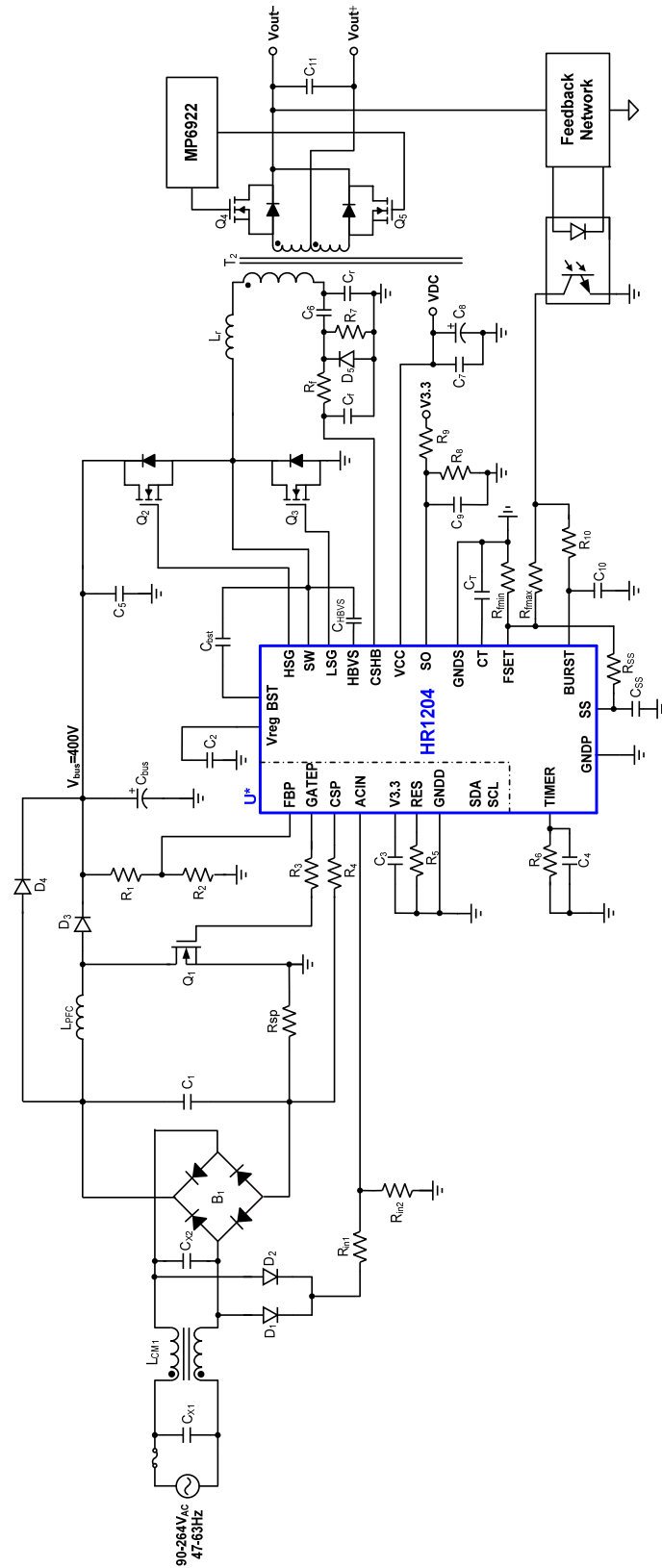

ORDERING INFORMATION

Part Number*	Package	Top Marking
HR1204GM-xxxx*	TSSOP28	See Below
HR1204GY-xxxx*	SOIC-28	

*-xxxx: internal code version control

For customer-specific projects, MPS will assign a special 4-digit suffix to the part number.

**For Tape & Reel, add suffix -Z (e.g.: HR1204GM-xxxx-Z, HR1204GY-xxxx-Z).

TOP MARKING

MPSYYWW
HR1204
LLLLLLLLL

MPS: MPS prefix

YY: Year code

WW: Week code

HR1204: First six digits of the part number

LLLLLLLLL: Lot number

PACKAGE REFERENCE

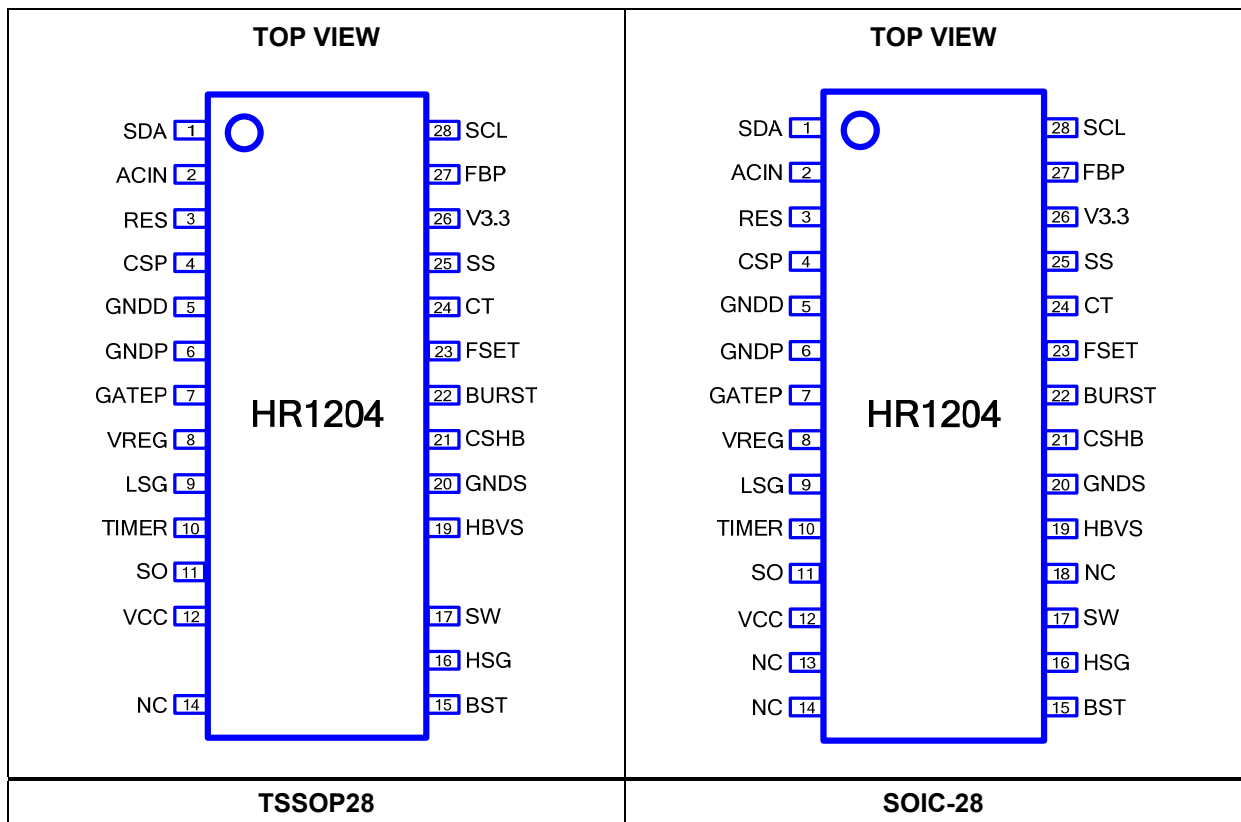

Recommended Operating Conditions ⁽¹⁾
 Supply voltage (V_{CC}) 14V to 30V
 Operating junction temp (T_J).....-40°C to +125°C

Thermal Resistance ⁽⁴⁾ **θ_{JA}** **θ_{JC}**
 TSSOP28 82 20 ... °C/W
 SOIC-28 60 30 ... °C/W

ABSOLUTE MAXIMUM RATINGS ⁽²⁾

Parameter	Symbol	Condition	Min	Max	Units
General					
Total power dissipation ⁽³⁾	P _{total}	T _{amb} = 25°C, TSSOP28		1.52	W
		T _{amb} = 25°C, SOIC-28		2.08	W
Storage temperature	T _{stg}		-55	+150	°C
Junction temperature	T _J		-40	+150	°C
Lead temperature	T _{LEAD}			260	°C
Voltage					
Floating supply voltage	V _{BST}		-1	+618	V
Floating ground voltage	V _{SW}		-3	+618	V
Voltage on high-side gate driver	V _{HSG}			+618	V
Floating ground max slew rate	dV _{SW} /dt			50	V/ns
Voltage on VCC	V _{CC}		-0.5	+38	V
Voltage on VREG	V _{reg}		-0.5	+14	V
VREG Supply Current	I _{reg}			50	mA
V3.3 Supply Current	I _{3v3}			20	mA
Voltage on low-side gate driver	V _{LSG}		-0.5	+14	V
Voltage on PFC gate driver	V _{PFCG}		-0.5	+14	V
Voltage on CS	V _{CS}		-6.5	+6.5	V
Voltage on HBVS	V _{HBVS}		-0.3	Self-limited	V
Other analog pins			-0.5	6.5	V
Others digital pins			-0.5	2	V
Analog ground to digital ground	GNDP/GNDS to GNDD		-0.3	+0.3	V
Current					
Current on HBVS	I _{HBVS}		-65	+65	mA
Source current of FSET	I _{FSET}			2	mA
ESD ⁽⁴⁾					
	All pins	Human body model		2000	V
	All pins	Machine model		200	V
	All pins	Charged device model		500	V

NOTES:

- 1) The device is not guaranteed to function outside of its operating conditions.
- 2) Exceeding these ratings may damage the device.
- 3) The maximum allowable power dissipation is a function of the maximum junction temperature T_J (MAX), the junction-to-ambient thermal resistance θ_{JA}, and the ambient temperature T_A. The maximum allowable continuous power dissipation at any ambient temperature is calculated by P_D (MAX) = (T_J (MAX) – T_A) / θ_{JA}. Exceeding the maximum allowable power dissipation produces an excessive die temperature, causing the regulator to go into thermal shutdown. Internal thermal shutdown circuitry protects the device from permanent damage.
- 4) Measured on JESD51-7, 4-layer PCB.

ELECTRICAL CHARACTERISTICS

$V_{CC} = 25V$, $T_J = -40^{\circ}C$ to $125^{\circ}C$, currents entering the IC are positive, min and max are guaranteed by characterization, typical is tested under $25^{\circ}C$, unless otherwise specified.

Parameter	Symbol	Condition	Min	Typ	Max	Units
IC Power Supply (VCC)						
IC turn-on threshold voltage	V_{CCON}		11.2	12.2	13.1	V
UV protection threshold	V_{CCUVP}		9.1	10	10.8	V
IC release threshold	V_{CCRST}		8.4	9	9.9	V
Operation current at normal	$I_{CC(nor)}$	$R_{RES} = 20k\Omega$, $f_{PFC} = 120kHz$, $f_{LLC} = 200kHz$		14		mA
Start-up current	$I_{CC-start1}$	$V_{CC} = 20V$		0.55	0.7	mA
Current at fault (LLC fault, PFC operation) ⁽⁵⁾	$I_{CC-Disable1}$	TIMER = 4V, PFC burst		4		mA
Current at fault (LLC fault, PFC fault) ⁽⁵⁾	$I_{CC-Disable2}$	TIMER = 4V		0.5		mA
Regulated Power Supply (VREG)						
Regulated output voltage	V_{reg}	$I_{reg} = 0mA$	11	12	12.8	V
		$I_{reg} = 30mA$	10.8	11.8	12.6	V
IC enable threshold	V_{regON}		9.6	10.2	10.8	V
UVP	V_{regUVP}		7.7	8.2	8.8	V
Power Supply for Digital Core (V3.3)						
Voltage regulation range	V_{3V3}	$I_{3V3} = 0mA$	2.95	3.15	3.45	V
		$I_{3V3} = 15mA$	2.85	3.1	3.35	V
PFC Gate Driver						
Sourcing capacity ⁽⁵⁾	I_{gate_sr}	$C_{Gate} = 1nF$		750		mA
Sinking capacity ⁽⁵⁾	I_{gate_sk}	$C_{Gate} = 1nF$		-800		mA
Gate-on resistor	$R_{on(H)}$	Sourcing 20mA		4.5		Ω
	$R_{on(L)}$	Sinking 20mA		2.5		Ω
Voltage fall time	T_f	$C_{Gate} = 1nF$		10		ns
Voltage rise time	T_r	$C_{Gate} = 1nF$		15		ns
Reference Current (RES)						
Voltage regulation range	V_{RT}	$T_J = 25^{\circ}C$	1.245	1.25	1.255	V
System Clock						
Clock frequency	f_{osc_nor}	At normal		19		MHz
	f_{osc_nopwm}	At fault or burst off		1		MHz
AC Input Sensing (ACIN)						
Voltage range		$K_{ACIN} = 0.0032$	0		1.6	V
PFC feedback (FBP)						
Voltage range		$K_{ACIN} = 0.0032$	0		1.6	V
Current Sense (CSP)						
Voltage range		$K_{ACIN} = 0.0032$	0		1.6	V
Bias current in CSP	$I_{csp-bias}$	$R_{RES} = 20k\Omega$	61	62.5	64	μA

ELECTRICAL CHARACTERISTICS (continued)

$V_{CC} = 25V$, $T_J = -40^{\circ}C$ to $125^{\circ}C$, currents entering the IC are positive, min and max are guaranteed by characterization, typical is tested under $25^{\circ}C$, unless otherwise specified.

Parameter	Symbol	Condition	Min	Typ	Max	Units
ADC for ACIN, FB and CSP						
ADC voltage reference		$T_J = 25^{\circ}C$	1.593	1.600	1.607	V
ADC resolution ⁽⁶⁾				10		bits
Acquisition time ⁽⁶⁾					350	ns
Integral non-linearity (INL) ⁽⁶⁾				± 7.0		LSB
Differential non-linearity (DNL) ⁽⁶⁾				± 4.5		LSB
Offset error ⁽⁶⁾				± 0.5		LSB
Gain error ⁽⁶⁾				± 1.5		LSB
DAC for OVP and OCL						
Reference voltage		$T_J = 25^{\circ}C$	1.593	1.600	1.607	V
Resolution ⁽⁶⁾				7		bits
Integral non-linearity (INL) ⁽⁶⁾				± 1.5		LSB
Differential non-linearity (DNL) ⁽⁶⁾				± 0.3		LSB
Offset error ⁽⁶⁾				± 0.2		LSB
Gain error ⁽⁶⁾				± 1.5		LSB
Output setting time ⁽⁶⁾				5		μs
DAC for Set Comparator						
Reference voltage		$T_J = 25^{\circ}C$	1.593	1.600	1.607	V
Resolution ⁽⁶⁾				10		bits
Integral non-linearity (INL) ⁽⁶⁾				± 4.5		LSB
Differential non-linearity (DNL) ⁽⁶⁾				± 2.0		LSB
Offset error ⁽⁶⁾				± 0.5		LSB
Gain error ⁽⁶⁾				± 1.5		LSB
Comparator for Set Signal, OVP, and OCL						
Offset voltage				60	360	mV
I²C Characteristics (SCL/SDA) ⁽⁵⁾						
Input high voltage (VIH)			2.1			V
Input low voltage (VIL)					0.8	V
Output low voltage (VOL)					0.4	V
I²C Timing Characteristics ⁽⁵⁾						
Operating frequency range				100	400	kHz
Bus free time		Between stop and start	4.7			μs
Holding time			4.0			μs
Repeated start condition set-up time			4.7			μs
Stop condition set-up time			4.0			μs
Data hold time			0			ns
Data set-up time			250			ns
Clock low time out			25		35	ms

ELECTRICAL CHARACTERISTICS (continued)

$V_{CC} = 25V$, $T_J = -40^{\circ}C$ to $125^{\circ}C$, currents entering the IC are positive, min and max are guaranteed by characterization, typical is tested under $25^{\circ}C$, unless otherwise specified.

Parameter	Symbol	Condition	Min	Typ	Max	Units
Clock low period			4.7			μs
Clock high period			4.0		50	μs
Clock/data fall time					300	ns
Clock/data rise time					1000	ns
High-Side Floating-Gate-Driver Supply (BST, SW)						
BST leakage current	I_{LKBST}	$V_{BST} = 600V$			10	μA
SW leakage current	I_{LKSW}	$V_{SW} = 582V$			10	μA
Current Sensing of Half-Bridge (CSHB)						
Frequency shift threshold	V_{CS-OCR}	OCR	0.7	0.77	0.83	V
OCP threshold	V_{CS-OCP}	OCP	1.41	1.48	1.55	V
Current polarity comparator reference when HSG is on	V_{CSPR}			80		mV
Current polarity comparator reference when LSG is on	V_{CSNR}			-80		mV
Output Voltage Sense (SO)						
Latch protection on SO	$V_{SO-Latch}$		3.22	3.42	3.6	V
Start-up failure protection on SO	V_{SO-SFP}		1.85	1.96	2.08	V
Pull-up current on SO	I_{SO-PU}			100		nA
Oscillator (FSET, CT)						
Output duty cycle	D	$T_J = 25^{\circ}C$	48	50	52	%
		$T_J = -40^{\circ}C$ to $125^{\circ}C$	47	50	53	%
Oscillation frequency	f_{osc}				600	kHz
CT peak value	V_{CTP}		3.54	3.74	3.94	V
CT valley value	V_{CTV}		0.79	0.87	0.95	V
Voltage reference at FSET	V_{REF}		1.88	1.97	2.06	V
Dead time	t_{DMIN}	$C_{HBVS} = 5pF$		240		ns
	t_{DMAX}		0.82	1.1	1.38	μs
Timer for CMP	t_{D_float}	HBVS floating	230	300	390	ns
	t_{D_CMP}			50		μs
Half-Bridge Voltage Sensing (HBVS)						
Voltage clamp	V_{HBVS-C}			7.5		V
Minimum voltage for the change rate to be detected	dv_{min}/dt	$C_{HBVS} = 5pF$, typically			190	$V/\mu s$
Turn-on delay	T_d	Slope finish to turn-on delay		130		ns
Soft-Start Function (SS)						
Discharge resistance	R_d	$V_{CS} > V_{CS-OCR}$		120		Ω
Threshold for OCP	V_{SS-OCP}	$V_{CS} > V_{CS-OCP}$	1.61	1.72	1.82	V

ELECTRICAL CHARACTERISTICS (continued)

$V_{CC} = 25V$, $T_J = -40^{\circ}C$ to $125^{\circ}C$, currents entering the IC are positive, min and max are guaranteed by characterization, typical is tested under $25^{\circ}C$, unless otherwise specified.

Parameter	Symbol	Condition	Min	Typ	Max	Units
Standby Function (BURST)						
Disable threshold	V_{th}		1.18	1.23	1.28	V
Hysteresis	V_{hys}			40		mV
Delayed Shutdown (TIMER)						
Charge current	I_{CHARGE}	$V_{TIMER} = 1V$, $V_{CS} = 0.85V$, $SO = 3V$	90	140	180	μA
Charge current for SFP	I_{CHARGE_SFP}	$SO < 2.5V$		25		μA
Threshold for forced operation at maximum frequency	V_{th1}		1.87	1.97	2.07	V
Shutdown threshold	V_{th2}		3.25	3.45	3.65	V
Restart threshold	V_{th3}		0.23	0.29	0.35	V
Low-Side Gate Driver (LSG)						
Peak source current ⁽⁵⁾	$I_{sourcepk}$			0.75		A
Peak sink current ⁽⁵⁾	I_{sinkpk}			0.87		A
Sourcing resistor	R_{source}			4		Ω
Sinking resistor	R_{sink}			2		Ω
Fall time	t_f			20		ns
Rise time	t_r			20		ns
High-Side Gate Driver (HSG, Referenced to SW)						
Peak source current ⁽⁵⁾	$I_{sourcepk}$			0.74		A
Peak sink current ⁽⁵⁾	I_{sinkpk}			0.87		A
Sourcing resistor	R_{source}			4		Ω
Sinking resistor	R_{sink}			2		Ω
Fall time	t_f			20		ns
Rise time	t_r			20		ns
Thermal Shutdown						
Thermal shutdown threshold				145		$^{\circ}C$
Thermal shutdown recovery threshold				100		$^{\circ}C$

NOTES:

- 5) Guaranteed by design.
 6) Guaranteed by characterization.

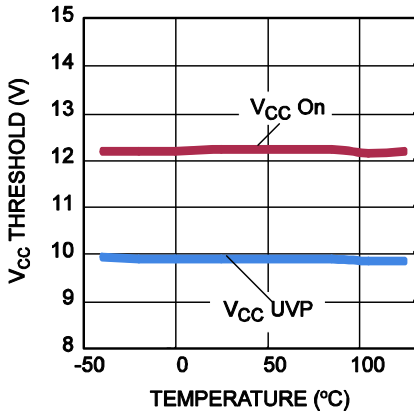
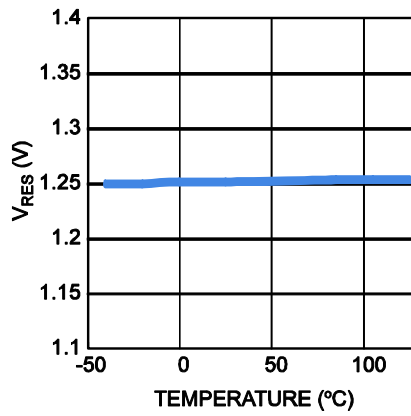
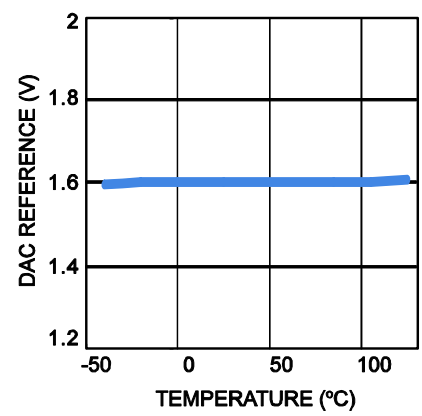
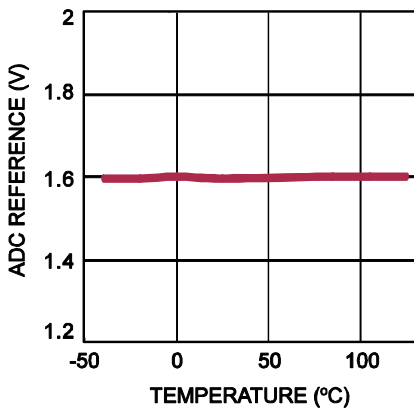
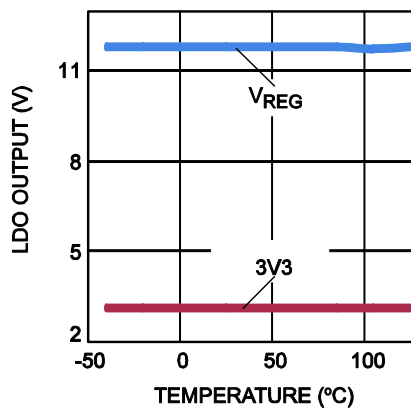
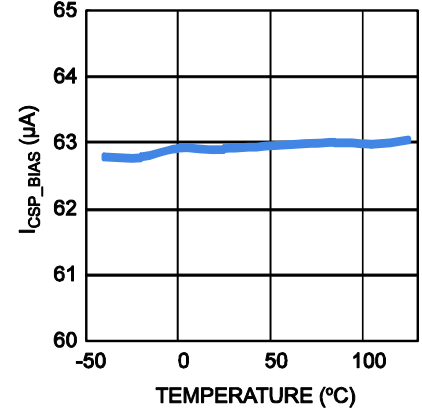
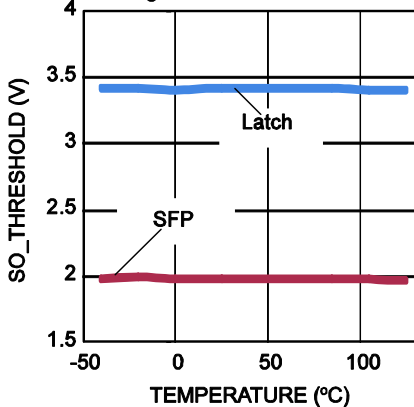
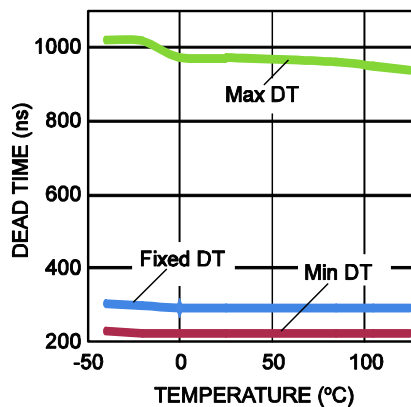
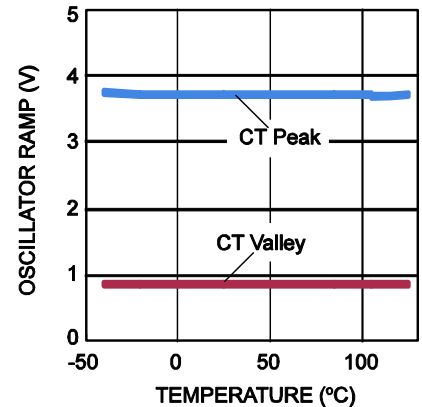
TYPICAL CHARACTERISTICS
V_{CC} On & UVLO vs. T_J

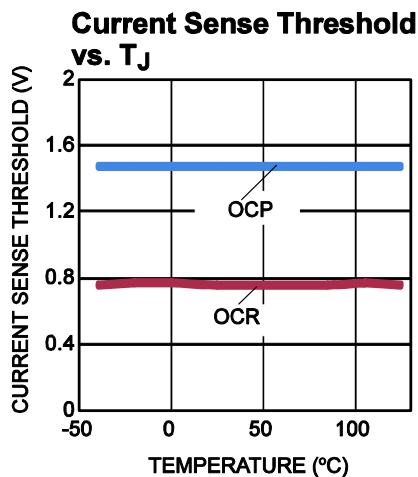
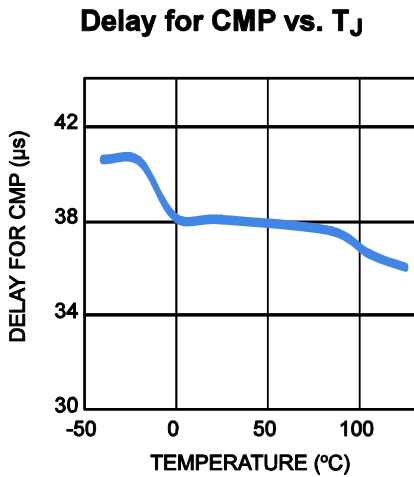
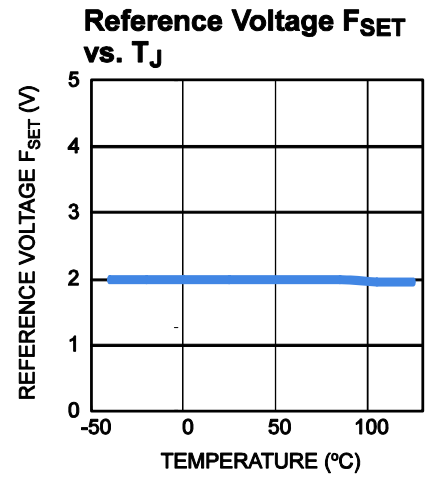
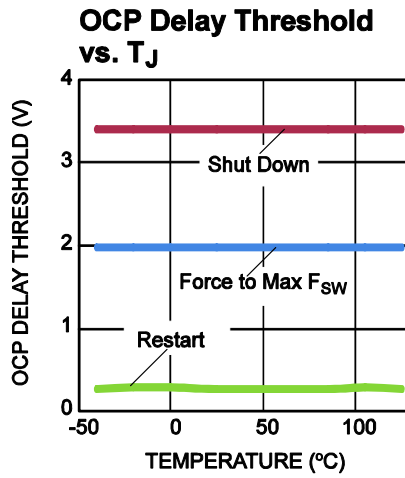
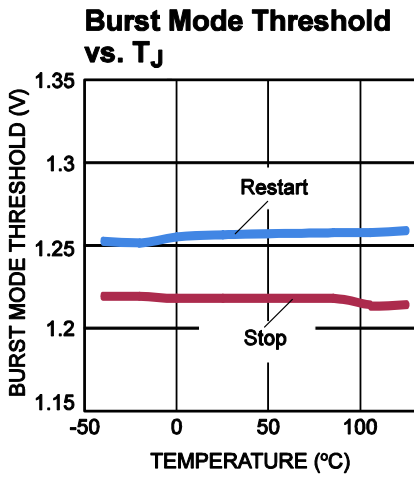
V_{RES} vs. T_J

DAC Reference vs. T_J

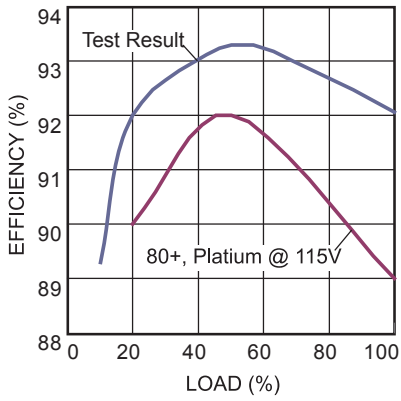
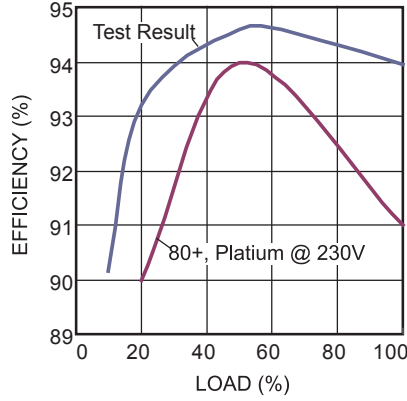
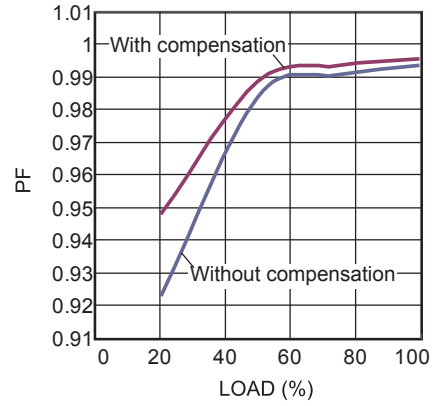
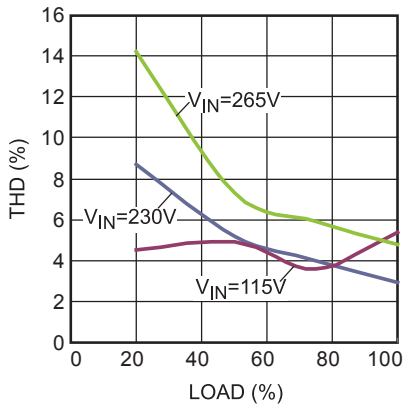
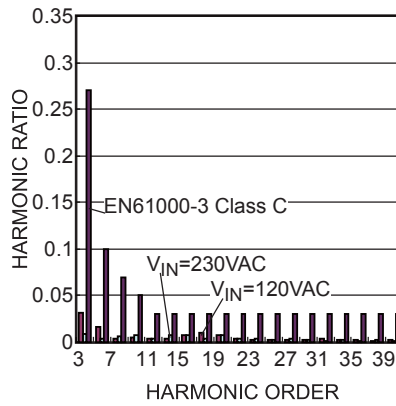
ADC Reference vs. T_J

LDO Output vs. T_J

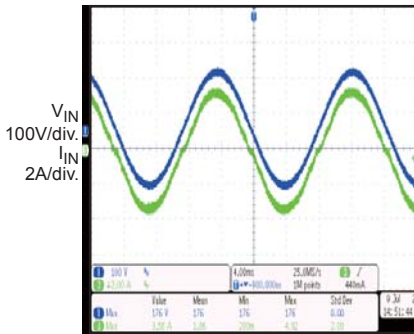
I_{CSP_Bias} vs. T_J

SO Threshold vs. T_J

Dead Time vs. T_J

Oscillator Ramp vs. T_J

TYPICAL CHARACTERISTICS *(continued)*

TYPICAL CHARACTERISTICS (continued)
 $V_{IN} = 85V \text{ to } 265V, V_{OUT} = 12V, I_{OUT} = 20A, T_A = 25^\circ C$, unless otherwise noted.

Efficiency
 $V_{IN}=115V, V_{OUT}=12V, P_{OMAX}=240W$

Efficiency
 $V_{IN}=230V, V_{OUT}=12V, P_{OMAX}=240W$

PF
 $V_{IN}=230V, V_{OUT}=12V, P_{OMAX}=240W$

THD (%)
 $V_{OUT}=12V, P_{OMAX}=240W$

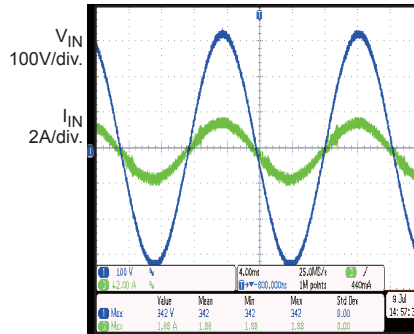
Harmonic
 $V_{IN}=120VAC/60Hz \text{ \& } 230VAC/50Hz, \text{ Full Load}$

TYPICAL CHARACTERISTICS (continued)
 $V_{IN} = 85V \text{ to } 265V, V_{OUT} = 12V, I_{OUT} = 20A, T_A = 25^\circ C$, unless otherwise noted.

Steady State @ Input
 $V_{IN} = 115VAC @ P_{OUT} = 240W$

4ms/div.

Steady State @ Input
 $V_{IN} = 230VAC @ P_{OUT} = 240W$

4ms/div.

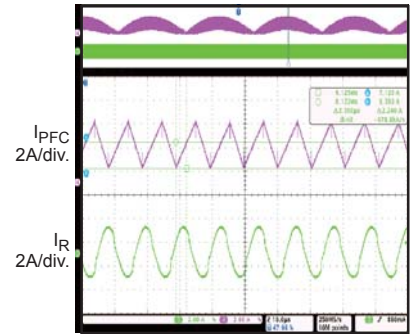
Steady State @ IPFC & IR
 $V_{IN} = 120VAC @ P_{OUT} = 240W$

10µs/div.

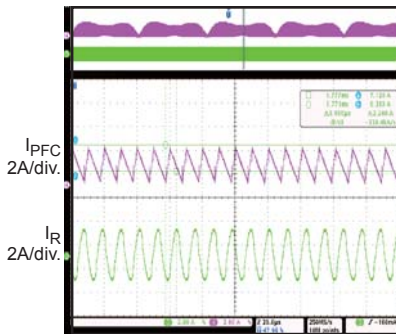
Steady State @ IPFC & IR
 $V_{IN} = 230VAC @ P_{OUT} = 240W$

20µs/div.

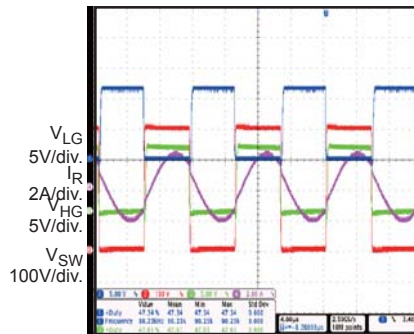
Steady State @ LLC
 $P_{OUT} = 240W$

4µs/div.

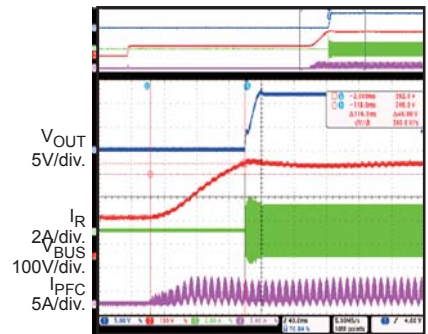
Start-Up
 $V_{IN} = 115VAC @ P_{OUT} = 240W$

40ms/div.

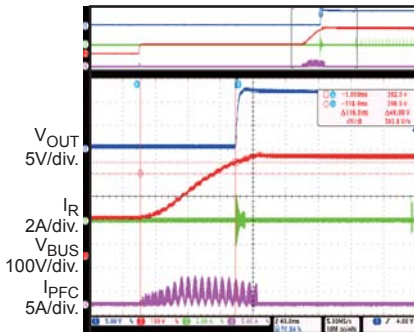
Start-Up
 $V_{IN} = 115VAC @ P_{OUT} = 0W$

40ms/div.

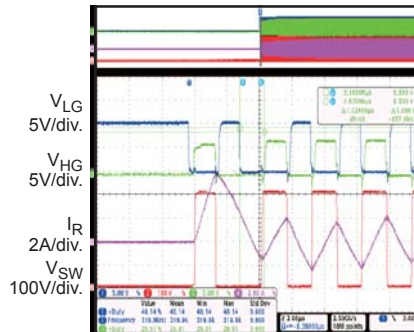
Start-Up @ LLC
 $P_{OUT} = 240W$

2µs/div.

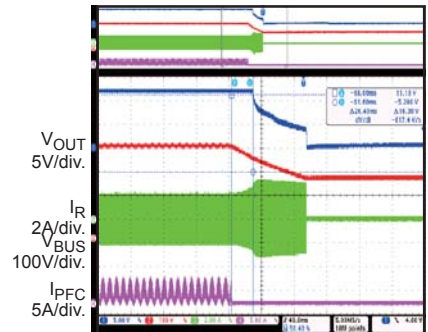
Shutdown
 $V_{IN} = 115VAC @ P_{OUT} = 240W$

40ms/div.

TYPICAL CHARACTERISTICS (continued)
 $V_{IN} = 85V \text{ to } 265V, V_{OUT} = 12V, I_{OUT} = 20A, T_A = 25^\circ C$, unless otherwise noted.

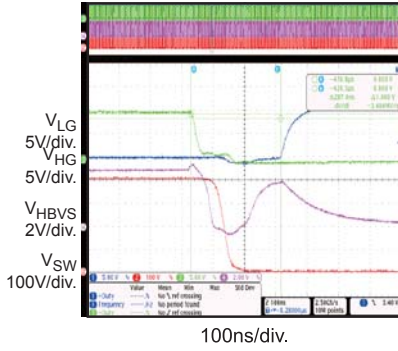
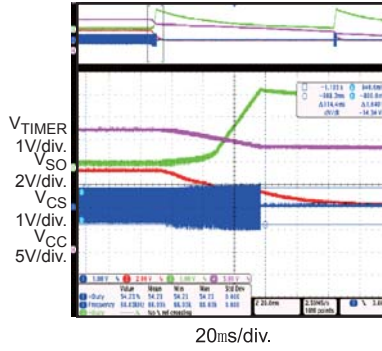
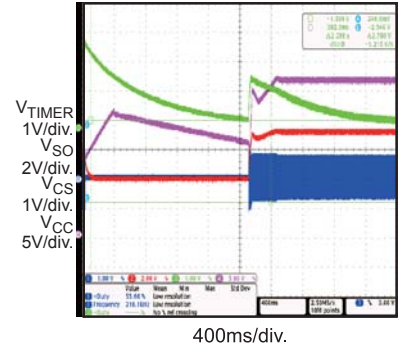
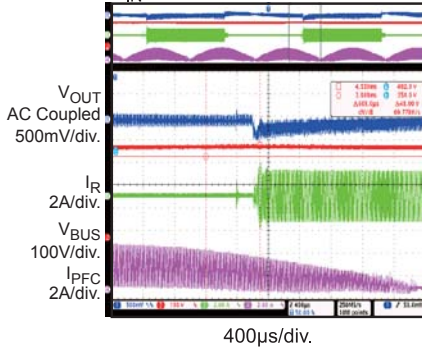
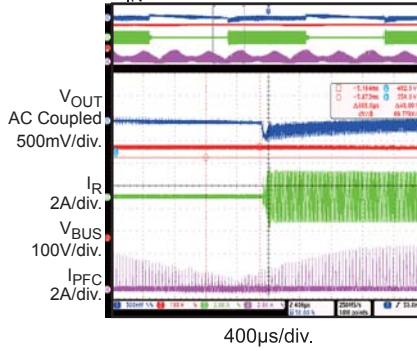
ADTA

Over-Current Protection

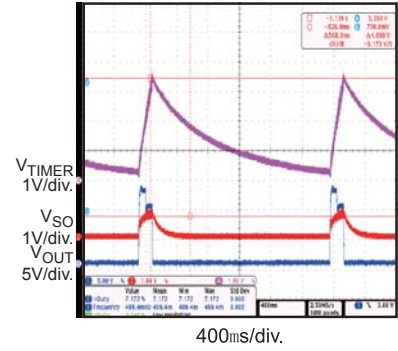
Over-Current Protection Recovery

Load Transient
 $P_{OUT} = 0W \text{ to } 240W, 1A/\mu s,$
 $V_{IN} = 90VAC$

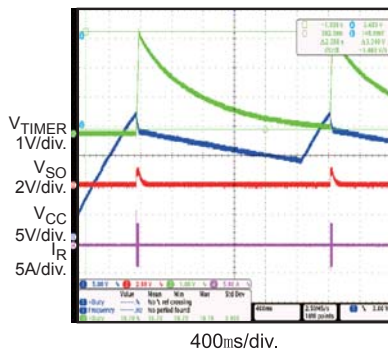
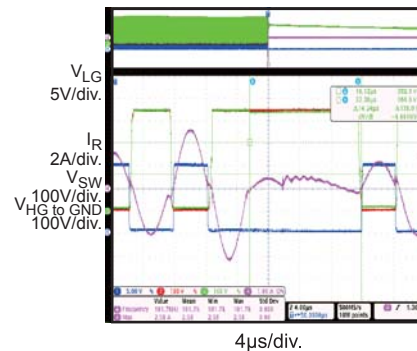
Load Transient
 $P_{OUT} = 0W \text{ to } 240W, 1A/\mu s,$
 $V_{IN} = 265VAC$

Start-Up Failure Protection

SO Pin Open

Start-Up Failure Protection

Output is Short



Capacitive Mode Protection

PIN FUNCTIONS

Package Pin #	Name	Description
1	SDA	I²C data bus. Connect a suitable pull-up resistor from SDA to V3.3.
2	ACIN	Input voltage sensing. ACIN is connected to ADC internally. The voltage is used for on-time calculation and brown-in/brown-out protection. The ratio of the external resistor divider should be 0.0032. It is recommended to connect a 680pF capacitor from ACIN to GNDD.
3	RES	Reference current for producing system clock and bias voltage on CSP. RES connects to a precise reference voltage of 1.25V internally. The reference current is produced by connecting a 20kΩ, 0.5% resistor externally from RES to GNDD.
4	CSP	Sensing of the PFC inductor current. Connect a 20kΩ, 0.5% resistor to CS to produce a bias voltage of 1.25V.
5	GNDD	Ground reference for the digital core of the PFC.
6	GNDP	Ground reference of the PFC gate driver and the LLC low-side gate driver.
7	GATEP	Gate driver output of the PFC MOSFET.
8	VREG	Regulated power supply. VREG provides a regulated power supply for the PFC and LLC gate drivers or external circuits.
9	LSG	Low-side gate driver of HB. The driver is capable of a minimum 0.7A sourcing current and a minimum 0.8A peak sinking current to drive the lower MOSFET of the half-bridge leg. LSG is actively tied to GND during UVLO.
10	TIMER	Setting of protection and recovery time. Connect a capacitor and a resistor from TIMER to GNDS to set both over-current protection delay and recovery delay.
11	SO	Latch protection and start-up failure protection. If the SO voltage exceeds $V_{SO-Latch}$, the IC stops switching immediately and remains latched off until VCC drops below V_{CCRST} . When the LLC is enabled during start-up, if the SO voltage is still below V_{SO-SFP} after the TIMER voltage reaches V_{th2} , the IC stops operating. Connect SO and GNDS with a noise-decoupling capacitor more than 100nF placed as close to the IC as possible.
12	VCC	IC supply power. VCC is connected to a DC supply.
13, 14, 18	NC	Not connected.
15	BST	Voltage bootstrap. BST is connected externally to a capacitor to build a power supply to drive the high-side MOSFET of the HB LLC.
16	HSG	High-side gate driver of HB. HSG is the gate driver output for the high-side MOSFET of the HB LLC.
17	SW	Reference of the high-side gate driver and bootstrap capacitor.
19	HBVS	Slope sensing to achieve adaptive dead-time adjustment. HBVS detects the dV/dt of the half-bridge mid-point. A 5pF high-voltage capacitor is recommended to be placed between SW and HBVS. LLC works with a fixed dead time (about 300ns) when HBVS is floating. Connecting HBVS to GNDS disables the LLC switching.
20	GNDS	Ground reference of LLC and power management circuits.

PIN FUNCTIONS (continued)

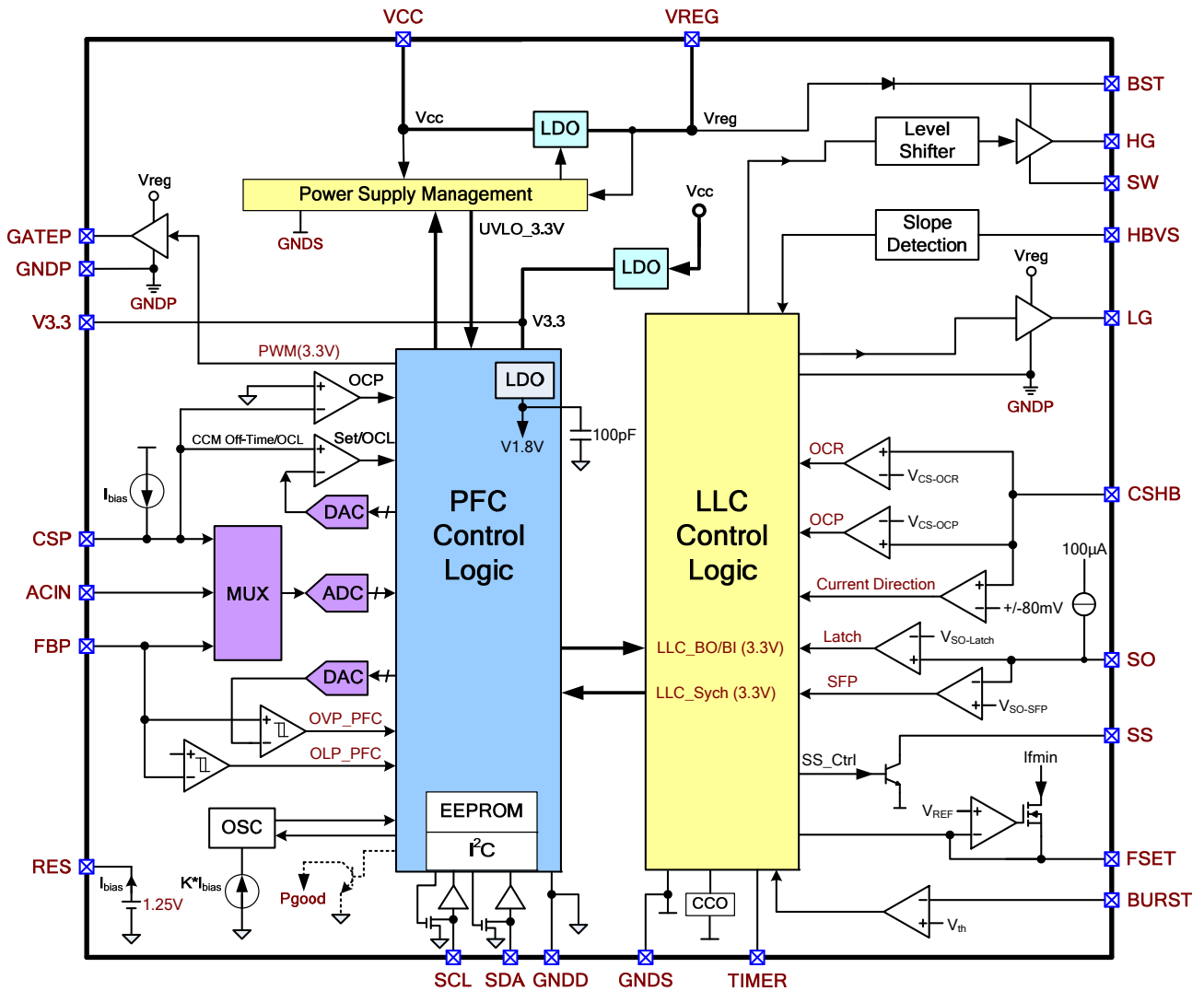
Package Pin #	Name	Description
21	CSHB	<p>Current sense of the half-bridge. The LLC current can be sensed by a sense resistor or a capacitive divider. CSHB has the following functions:</p> <ol style="list-style-type: none"> 1. Over-current regulation: As the voltage exceeds the V_{CS-OCR} threshold, the soft-start capacitor on SS discharges internally. The frequency increases, limiting the output power. An output short circuit results in a nearly constant peak primary current. A timer set on ACIN limits the duration of this condition. 2. Over-current protection: If the current continues to build up (despite the frequency increase) when the CSHB voltage reaches V_{CS-OC}, C_{SS} is discharged continuously, and OCP is not triggered immediately until $V_{SS} < V_{SS-OC}$. If the condition for $V_{CS} > V_{CS-OC}$ remains once V_{SS} drops below V_{SS-OC}, the IC shuts down. C_{TIMER} continues to be charged by an internal 140μA current source until the TIMER voltage reaches V_{th2}. The IC resumes operation when the TIMER voltage falls below V_{th3}. 3. Capacitive mode protection: The moment LSG is turned off, the CSHB voltage level is compared with a -80mV CMP threshold. If $CSHB > -80mV$, it blocks the HSG gate output until the slope comes down or the CMP timer runs out. Once HSG is turned off, CSHB is compared with a +80mV CMP threshold. If $CSHB < +80mV$, the LSG gate output is blocked until the slope comes up or the CMP timer runs out. Once capacitive mode is detected, the soft-start capacitor on SS discharges internally and the frequency increases. <p>All functions are disabled when CSHB is connected to GND.</p>
22	BURST	<p>Burst mode control. If the voltage on BURST is lower than V_{th} (1.23V), the IC is disabled and resumes when the voltage exceeds 1.23V with a hysteresis of about 40mV. During burst mode, soft start is not activated. This function helps reduce power loss at a lighter load.</p>
23	FSET	<p>Switching frequency set. FSET provides a precise and stable reference voltage (1.97V). Current flowing out of FSET regulates the LLC switching frequency and output voltage. The minimum frequency is set via a resistor connected to GND. The resistor connecting the optocoupler and FSET sets the maximum frequency. An R-C series connected from FSET to GND determines the specific operating frequency.</p>
24	CT	<p>Time set. Current flowing out of FSET is mirrored to charge and discharge the capacitor connected from CT to GNDS, which determines the LLC switching frequency.</p>
25	SS	<p>Soft-start for LLC. Connect an external capacitor from SS to GND and a resistor to FSET to set both the maximum oscillating frequency and the time constant for the frequency shift during start-up. An internal switch discharges the capacitor when the chip is turned off to guarantee soft start (all protections are listed except CMP).</p>
26	V3.3	<p>A stable 3.3V voltage for digital PFC core or external circuit. A 10μF decoupling ceramic capacitor is recommended to connect V3.3 and GNDS.</p>
27	FBP	<p>Voltage sensing of PFC output. The voltage of FBP is sampled by ADC. FBP is also used for on-time calculation, OVP, OLP, and digital PI. A 3.3MΩ pull-down resistor is connected internally. It is recommended to connect a 680pF capacitor from FBP to GNDD.</p>
28	SCL	<p>I²C serial clock input. Connect a suitable pull-up resistor from SCL to V3.3.</p>

BLOCK DIAGRAM

Figure 1: Functional Block Diagram

PART 1: POWER SUPPLY MANAGEMENT

The power supply management function is implemented via three output pins: VCC, VREG, and V3.3. Figure 3 and Figure 4 show the block diagram and operation waveforms of the power management circuit.

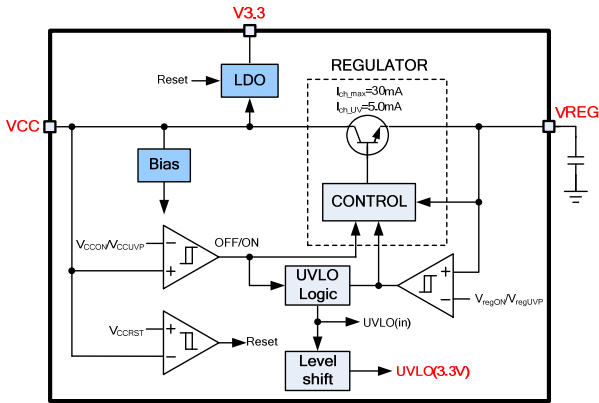

Figure 3: Block Diagram of Power Supply

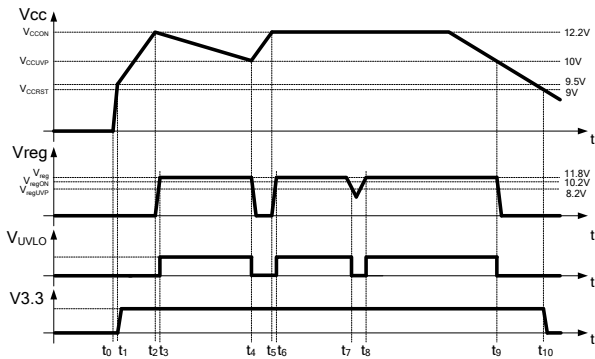

Figure 4: Operation Waveforms of Power Supply

IC Supply Input (VCC)

VCC provides operational power for most of the internal circuits. When VCC reaches its start level (V_{CCON}), the internal LDO is powered on. VREG begins building up, and the IC starts operating if no fault condition occurs. If VCC drops below V_{CCUVP} , the following actions occur:

- The IC stops operating, and the PFC controller stops switching immediately. The HB LLC controller continues to operate until the low-side MOSFET is turned on.
- The VREG LDO is disabled.

If the IC enters latch mode, the latch status remains until VCC falls below V_{CCRST} .

Regulated Output (VREG)

An internal LDO is added to stabilize the voltage to supply the internal PFC driver, the internal low-side driver of HB LLC, the internal high-side driver of HB LLC via a bootstrap diode, and a reference voltage.

The LDO is enabled only when VCC is higher than V_{CCON} . This ensures that any optional external circuitry connected to VREG does not dissipate any of the start-up current.

The IC starts switching only when VREG is higher than V_{regON} (typically 10.2V). If VREG falls below V_{regUVP} (typically 8.2V), the IC and the PFC controller stop switching immediately. The HB LLC controller continues operating until the low-side MOSFET is turned on.

V3.3 for Digital Logic

V3.3 is a stabilized power supply for the internal digital logic. V3.3 is the output of an LDO with its input connected to VCC internally. The output of V3.3 is connected to a digital section with an internal bonding wire. When VCC is larger than V_{CCRST} plus a hysteresis of about 0.5V, the V3.3 LDO is enabled. It can be disabled only when VCC is lower than V_{CCRST} .

The capacitor on V3.3 should be in the range of 4.7 - 10 μ F to guarantee that V3.3 is stable.

Some internal digital circuits are biased off 1.8V, which is powered by an LDO that uses the 3.3V as the input.

UVLO (3.3V Signal)

The under-voltage lockout (UVLO) (3.3V signal) is an enable signal for both the digital PFC and LLC controller. When VCC is larger than V_{CCUVP} and VREG is larger than V_{regON} , UVLO (3.3V signal) goes high.

PART 2: SYSTEM FUNCTIONS

Over-Temperature Protection (OTP)

Once the internal thermal sensor senses that the IC temperature is over 145°C, the IC stops switching immediately. Both the LDO for VREG and V3.3 are disabled. The IC is enabled again when VCC drops below V_{CCRST} . If the IC temperature drops below 100°C, the IC starts up again.

IC On/Off Control

The IC is turned off by pulling FBP down to GND with an external MOSFET (see Figure 5). If the FBP voltage is less than 0.2V, both the PFC and LLC disable the PWM switching during start-up or operation. When the FBP voltage is higher than 0.3V, the IC is turned on again. The IC can be turned off from the secondary side through an optocoupler.

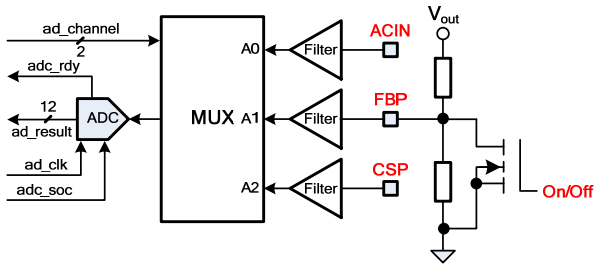

Figure 5: IC On/Off Control

The IC can be disabled by programming the EEPROM through the I²C GUI (see Table 1).

Table 1: IC Disabled through I²C and MPS GUI

Register address	56h							
Bit	7	6	5	4	3	2	1	0
Access	r/w	r/w	r/w	r/w	r/w	r/w	r/w	r/w
Function			IC enable: "1", enable IC "0", disable IC	LLC enable: "1", enable LLC "0", disable LLC				

PFC and LLC Interface

There are two signals between the PFC and the LLC part.

1. D2D brown-in/out signal:

If the output voltage is higher than V_{D2D_BI} , the D2D_BI/BO signal is set high, enabling the LLC stage. The LLC stage is disabled when the output voltage drops below V_{D2D_BO} . This function guarantees that the LLC operates within a proper input voltage range, preventing the LLC from running in capacitive mode (see Figure 6).

V_{D2D_BI} and V_{D2D_BO} are programmable through the I²C. The register address for V_{D2D_BI} is one word (16h, 17h). The register address for V_{D2D_BO} is one word (18h, 19h). The value in the register can be calculated with Equation (1):

$$\text{DEC2HEX} \left(V_{D2D_BI/BO} \times 0.0032 \times \frac{1023}{1.6} \right) \quad (1)$$

2. LLC burst synchronize signal:

When the LLC operates in burst mode, the PFC burst mode can be synchronized with the LLC burst mode. This is achieved by setting bit[7] of register 56h high. When bit[7] is low, the LLC and PFC burst independently.

PART 3: PFC CONTROLLER

The state-of-the-art continuous conduction mode (CCM)/discontinuous conduction mode (DCM) control schemes can reduce the RMS current drawn from the AC mains by ensuring good shape of the input current both in CCM and DCM. The control schemes reduce the switching frequency when the load is reduced, therefore achieving higher efficiency and higher power factor at light load.

Digital PFC Timing

Figure 6 shows the timing of the digital PFC block.

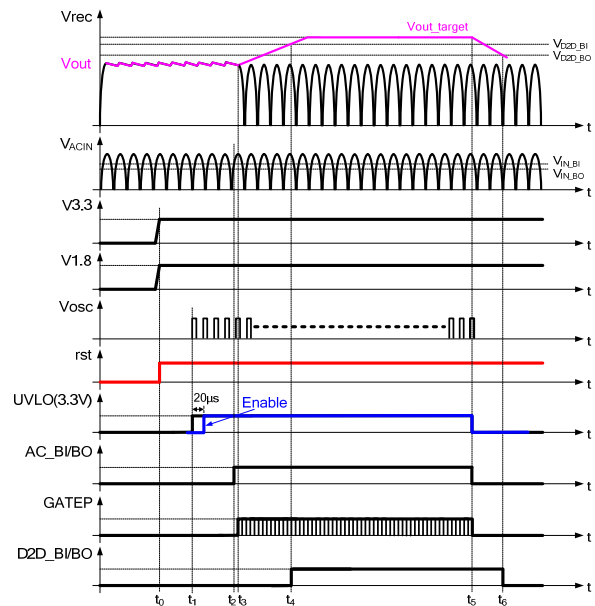

Figure 6: Power Supply Sequence of Digital Controller

Timing of the Power Supply

Once VCC rises above V_{CCRST} plus a hysteresis of about 0.5V, the 3.3V LDO is enabled and an internal LDO downstream produces a stable 1.8V power supply for the internal digital logic and system clocks. The rst signal is set high when both 3.3V and 1.8V are stable. When UVLO (3.3V signal) is validated, the IC enables OSC, ADC, DAC, and relative comparators.

The enable signal is set high after a delay of 20μs, which indicates that the digital core is ready to begin operation.

Timing of the Digital Core

If the enable signal is high, ADC begins sampling V_{ACIN} and V_{FBP} . If the AC input meets the brown-in condition and no open-loop fault is found on FBP, the AC_BI/BO signal is set high. The PFC soft starts until the output reaches the target value. If the PFC output voltage ramps up above V_{D2D-BI} , D2D_BI/BO is set high. The downstream LLC begins operation.

Reference Current (RES)

RES is connected internally to a precise reference voltage of 1.25V. RES should be connected to a 20kΩ, 0.5% resistor externally. A reference current of about 62.5μA is then generated. The current is mirrored and flows out of CSP. If CSP is also connected externally to a 20kΩ resistor, a bias voltage of 1.25V on CSP is produced, which keeps the CSP voltage positive (see Figure 7).

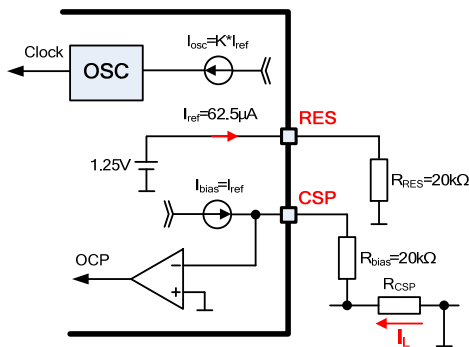

Figure 7: Reference Current

Moreover, the reference current is mirrored to produce a system clock (see Figure 8).

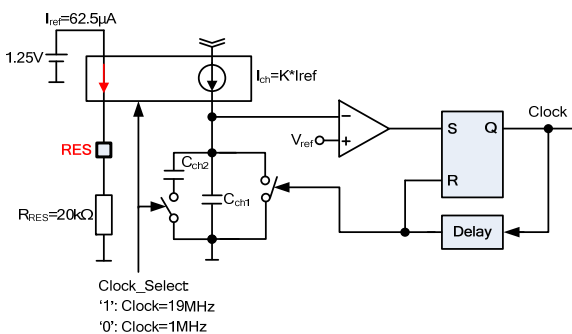

Figure 8: System Clock Generator

The system clock switches from 19MHz to 1MHz when PWM is disabled (i.e.: burst off, OVP, OCP, etc.) to reduce IC power consumption.

Input Voltage Sensing

The input voltage is rectified and attenuated by a resistor divider with a fixed ratio (0.0032) before it is provided to the ACIN input. Then, the ADC samples the voltage on ACIN, including the instantaneous value, the peak value, and the frequency of the input voltage. The data are used for on-time calculation, AC brown-in/-out protection, and capacitor current compensation.

Figure 9 shows the input voltage level defined for different functions. All parameters can be programmed through the I²C and MPS GUI.

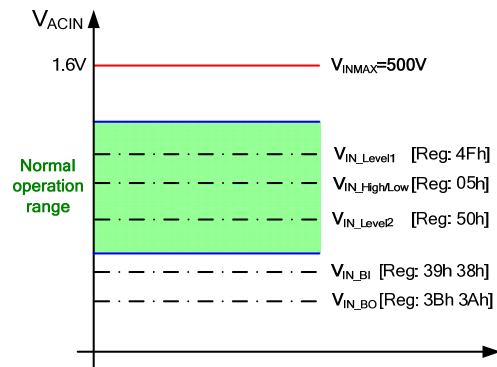

Figure 9: Input Voltage Level for Different Functions

Input Brown-In/Brown-Out

If V_{ACIN} is larger than the brown-in threshold (V_{IN_BI}), then the IC is ready to switch. If V_{ACIN} is less than the brown-out threshold (V_{IN_BO}) for the length of one timer period, the IC stops switching. V_{IN_BI} and V_{IN_BO} are 10-bit values that are stored in registers 38h to 3Bh. The values can be calculated with Equation (2):

$$\text{DEC2HEX} \left(V_{IN_BI/BO} \times 0.0032 \times \frac{1023}{1.6} \right) \quad (2)$$

The brown-in and brown-out timers are set in register 3Ch (see Table 2).

Table 2: Brown-In/Out Timer in Register 3Ch

Bit	Item	Description
7:4	VIN_BI_TIME	Brown-in time
3:0	VIN_BO_TIME	Brown-out time

High/Low Line

The low line is determined when the input voltage is lower than $V_{IN_High/Low}$. The high line is determined when the input voltage is larger than $V_{IN_High/Low}$ plus a hysteresis of about 10V. The high/low-line signal sets the soft-start time and the resonant time for valley turn-on and also regulates the output voltage at different levels to optimize the efficiency of the PFC stage.

V_{IN_Level1} , $V_{IN_High/Low}$, and V_{IN_Level2} separate the input voltage into four ranges to achieve different compensation values to improve the power factor at different input voltage ranges.

The thresholds are 8-bit data. The value can be set according to Equation (3):

$$DEC2HEX \left(V_{IN_High/Low} \times 0.0032 \times \frac{256}{1.6} \right) \quad (3)$$

Output Voltage Sensing

Similar to input voltage sensing, the output voltage is attenuated by a resistor divider before connecting to FBP. Then the voltage on FBP is sampled by ADC. The results are used for on-time calculation and a series of protections.

The internal pull down resistor of 3.3MΩ should be considered when designing the external resistors. Make the total divided ratio to 0.0032 according to Equation (4):

$$\frac{R_{FBL-L} // 3.3M\Omega}{R_{FBL-H} + (R_{FBL-L} // 3.3M\Omega)} = 0.0032 \quad (4)$$

Where R_{FBL-H} is the divider resistor connected on high-side and R_{FBL-L} is the divider resistor connect on low-side.

Figure 10 shows the output voltage level defined for different functions. All parameters can be programmed through the I²C GUI.

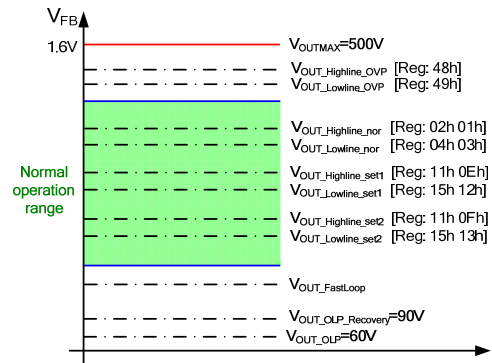

Figure 10: Output Voltage Level for Different Functions

Output Regulation

To optimize efficiency, the output voltage can be auto-regulated according to the input voltage and output power. The output voltage is divided into two ranges by $V_{IN_High/Low}$ and is divided into three ranges according to the output power level, which can be programmed by registers 06h to 09h. Therefore, the IC can auto-regulate six output voltages accordingly.

Output Fast OVP

$V_{OUT_Highline_OVP}$ and $V_{OUT_Lowline_OVP}$ are 7-bit values stored in register 48h and 49h. They are programmable through the I²C GUI (typically 430V). A 7-bit DAC converts V_{OUT_OVP} to an analog signal and compares the result with the FBP voltage. If the output voltage is larger than V_{OUT_OVP} , the PFC stops switching. Once the output voltage decreases to regulation voltage, the PFC resumes switching (see Figure 11).

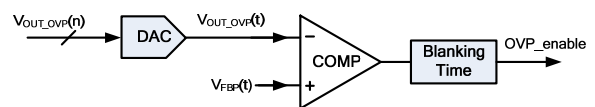

Figure 11: OVP Circuit

A blanking time is inserted into OVP, keeping the IC immune to switching noise interference (see Figure 12). Both T_{OVP_T} and T_{OVP_R} are programmable in register 60h.

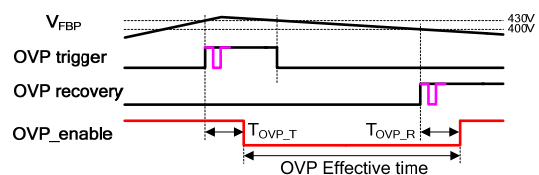

Figure 12: Output Fast OVP

Fast Loop

In a dynamic load event, the PFC output voltage decreases due to the low bandwidth of the voltage control loop, which causes the output voltage to fall out of regulation. Fast loop is activated when the output voltage is lower than $V_{OUT_Fastloop}$. Then K_i and K_p of the digital PI are changed by X times the normal value depending on the GUI setting. In this way, the output voltage of the PFC is regulated faster in the dynamic load event.

Open Loop or IC Disable Condition

If the FBP voltage is less than V_{OUT_OLP} (typically 60V), it is considered to be an open-loop or IC disable condition. The IC does not work, and PWM switching is disabled. The IC restarts only when the FBP voltage is larger than $V_{OUT_OLP_Recovery}$ (typically 90V). The open loop is achieved by software and the value is fixed.

Peak Current Sensing

The PFC inductor current is sensed by R_{CSP} and produces a negative voltage. The CSP pin sources out a precise current (I_{bias}) to produce a positive bias voltage on R_{bias} (see Figure 13).

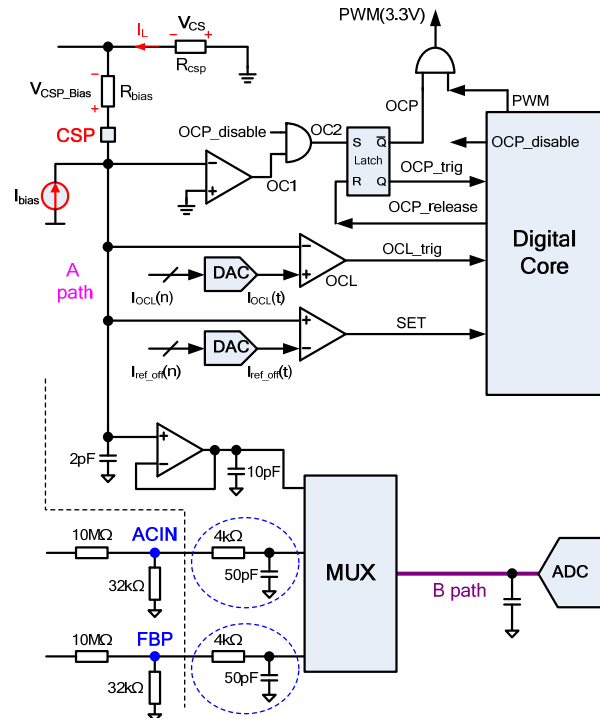

Figure 13: Current Sense Circuit in CSP

The CSP voltage is calculated with Equation (5):

$$V_{CSP}(t) = V_{CSP_Bias}(t) - V_{CS}(t) \quad (5)$$

Overall, the CSP voltage is positive (see Figure 14). ADC samples V_{CSP_Bias} (typically 1.25V) regularly.

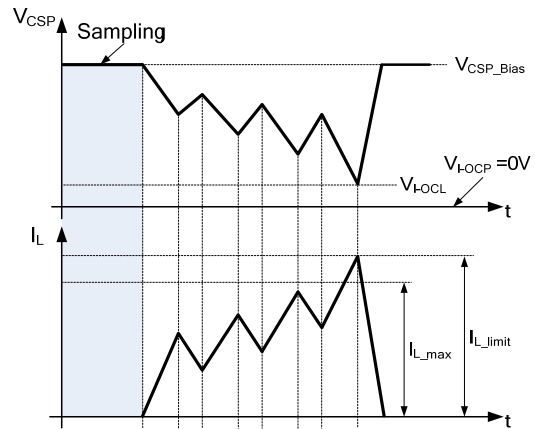

Figure 14: Voltage Waveform in CSP

Over-Current Protection (OCP)

If the CSP voltage is less than zero, over-current protection (OCP) is enabled. The PFC stops switching immediately, and OCP_trig is set high simultaneously. The digital core detects this status and disables PWM. OCP can be released by the $OCP_release$ signal.

The OCP function is disabled by setting bit[3] of register 45h to logic low. The OCP behavior mode can be programmed by setting bit[2] to bit[0] of register 45h. It can be hiccup, latch, or auto-restart with a delay time. The default setting is hiccup. The delay time is set in register 46h.

A programmable LEB1 ($T_{OCP_blinking}$) of about 200ns is implemented to avoid error sensing due to switching noise.

The OCP function can avoid over-stressing when the inductor is shorted or when the current is too large.

Figure 15 shows the operating waveforms of the OCP function.

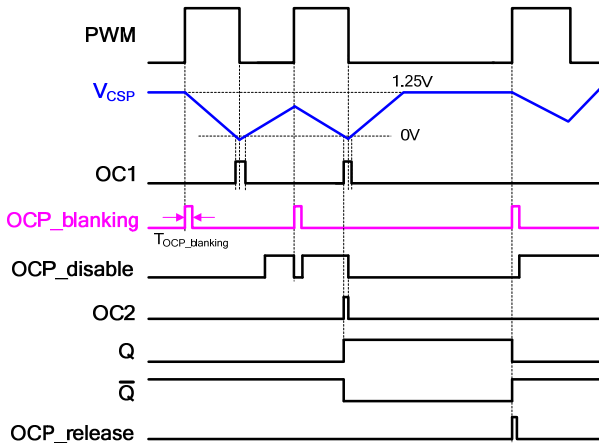
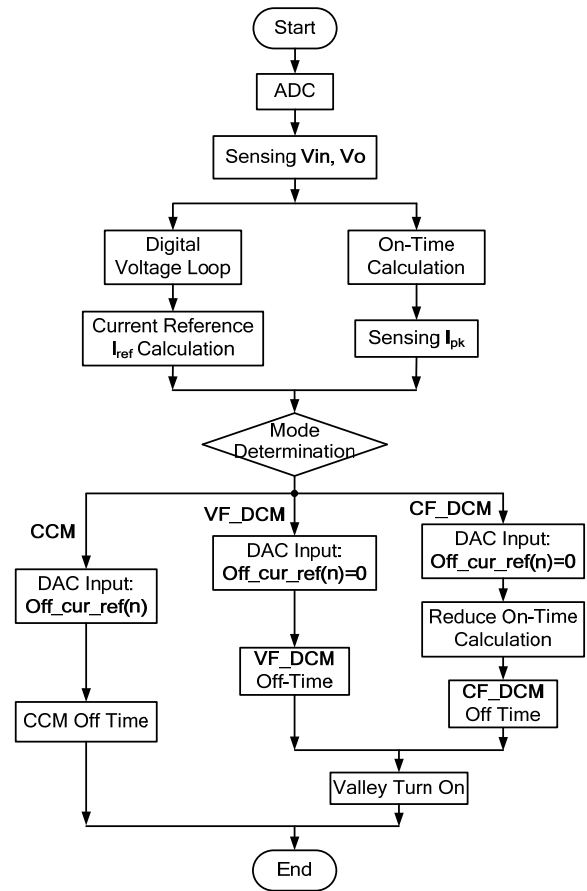

Figure 15: OCP Operation Waveform

Over-Current Limit (OCL)

The inductor current achieves a cycle-by-cycle limit by setting the appropriate R_{CSP} and V_{I-OCL} . V_{I-OCL} can be programmed in register 44h and can be converted to an analog signal by a 7-bit DAC. A programmable LEB1 ($T_{OCL_blinking}$) of about 200ns is inserted to avoid switching noise if the digital core is turned on (similar to $T_{OCP_blinking}$).

Digital PFC Control Scheme

Figure 16 shows the flowchart of the digital PFC control scheme.

Figure 16: Flowchart of PFC Control Scheme

Digital Current Reference

The digital PI compensates for the voltage loop. Its output $V_{comp}(n)$ is sent to the multiplier for current reference calculation (see Figure 17).

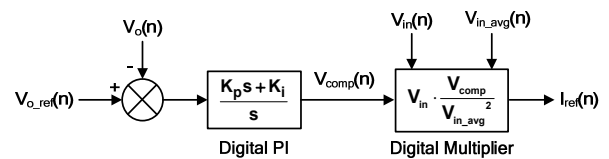
Figure 17: Current Reference

The digital current reference is calculated with Equation (6):

$$I_{ref}(n) = V_{in}(n) \cdot \frac{V_{comp}(n)}{(0.5 \cdot V_{in_pk}(n))^2} \quad (6)$$

On-Time Calculation

The on time can be calculated with Equation (7):

$$T_{on}(n) = \frac{V_{o_ref} - V_{in}(n)}{V_{o_ref}} \cdot T_s \quad (7)$$

Where T_s is the switching period, programmable in registers 1Eh to 22h.

Mode Decision

The HR1204 has three operation modes: continuous conduction mode (CCM), variable frequency discontinuous conduction mode (VF-DCM), and constant frequency discontinuous conduction mode (CF-DCM).

The peak value of the inductor current in CCM should satisfy Equation (8):

$$I_{pk}(n) < 2 I_{ref}(n) \quad (8)$$

The peak value of the inductor current in VF-DCM should satisfy Equation (9):

$$2 I_{ref}(n) < I_{pk}(n) < 2 I_{ref}(n) \cdot \frac{T_{s_max}}{T_s} \quad (9)$$

The peak value of the inductor current in CF-DCM should satisfy Equation (10):

$$I_{pk}(n) > 2 I_{ref}(n) \cdot \frac{T_{s_max}}{T_s} \quad (10)$$

Where T_{s_max} is the maximum switching period, programmable in registers from 23h to 27h.

1. CCM Operation:

When the converter operates in CCM, the $off_cur_ref(n)$ is calculated and sent to the DAC. The output of the DAC is an analog signal ($off_cur_ref(t)$) and is compared with $V_{CS}(t)$. If $V_{CS}(t)$ is lower than $off_cur_ref(t)$, the signal is set high. The PWM signal is set high accordingly (see Figure 18).

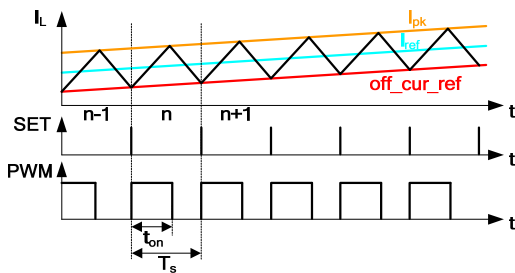

Figure 18: CCM Control Signals

The off current reference at CCM can be calculated with Equation (11):

$$off_cur_ref(n) = 2 I_{ref}(n) - I_{pk}(n) \quad (11)$$

2. VF-DCM Operation:

When the converter operates in VF-DCM, the off current reference is set to zero. In this case, the set signal represents the boundary of DCM (see Figure 19).

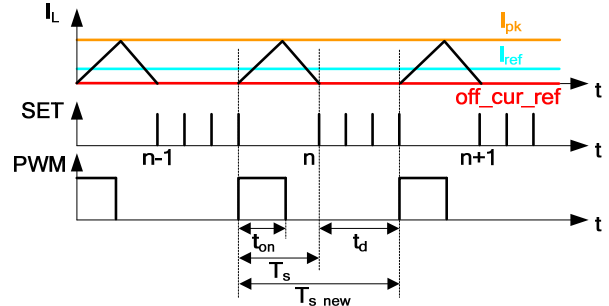

Figure 19: VF-DCM Control Signals

The new switching period is calculated with Equation (12):

$$T_{s_new}(n) = \frac{I_{pk}(n)}{2 I_{ref}(n)} T_s \quad (12)$$

The delay time is calculated with Equation (13):

$$t_d(n) = T_{s_new}(n) - T_s = \left(\frac{I_{pk}(n)}{2 I_{ref}(n)} - 1 \right) \cdot T_s \quad (13)$$

3. CF-DCM Operation:

When the converter operates in CF-DCM, the off current reference is set to zero. In this mode, the switching frequency is limited to the minimum switching frequency (see Figure 20).

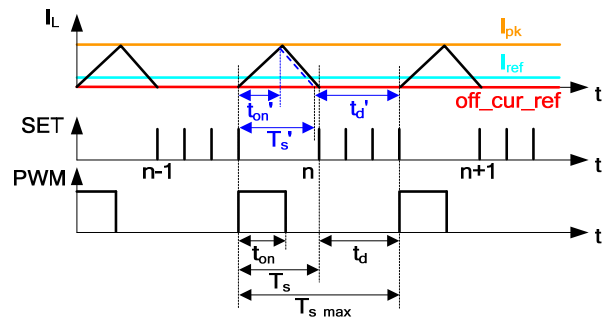

Figure 20: CF-DCM Control Signals

The PWM duty is modulated to achieve average current control. The new switching period is calculated with Equation (14):

$$T'_s(n) = \frac{2 I_{ref}(n)}{I_{pk}(n)} \cdot T_{s_max} \quad (14)$$

As t_{on} changes minimally, the peak value of inductor current can be seen as unchanged. See Equation (15):

$$I_{pk}'(n) = I_{pk}(n) \quad (15)$$

The new turn-on time can be calculated with Equation (16):

$$t_{on}'(n) = \frac{V_{o_ref} - V_{in}(n)}{V_{o_ref}} \cdot T_s'(n) \quad (16)$$

The delay time is calculated with Equation (17):

$$t_d'(n) = T_{s_max} - T_s'(n) = \left(1 - \frac{2I_{ref}(n)}{I_{pk}(n)}\right) \cdot T_{s_max} \quad (17)$$

Programmable Digital Filter

The HR1204 implements two programmable digital filters (I_{ref_filter} and Td_filter) internally for noise immunity improvement. Register 3Dh is used to enable/disable each filter and program the bandwidth of the filters.

As shown in Figure 21, I_{ref_filter} is implemented on the input of the PFC SET comparator. It helps reduce the current distortion and the audible noise in CCM operations.

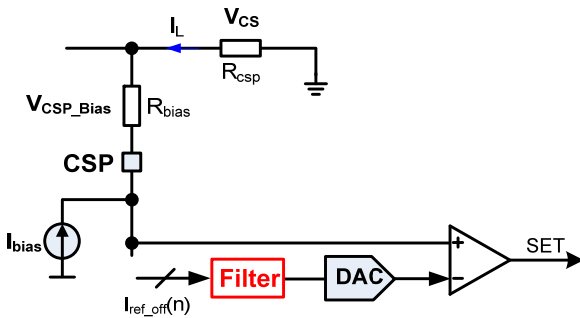

Figure 21: Iref_filter Circuit

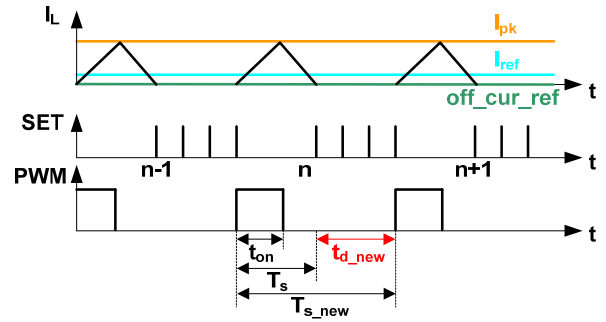

Figure 22: Td Control Signals

As shown in Figure 22, Td_filter is implemented in the calculation of the delay time. It helps reduce the current distortion in DCM operations. With Td_filter , the new delay time can be calculated with Equation (18):

$$t_{d_new}(n) = A \cdot t_d(n) + (1 - A) \cdot t_{d_new}(n-1) \quad (18)$$

Where A is a coefficient related to the bandwidth of the Td_filter . The bandwidth should be selected according to practical applications.

Soft Start (SS)

Once the AC input voltage is larger than V_{IN_BI} , the Vin_ok signal pulls high, and the HR1204 initiates a soft-start sequence (see Figure 23).

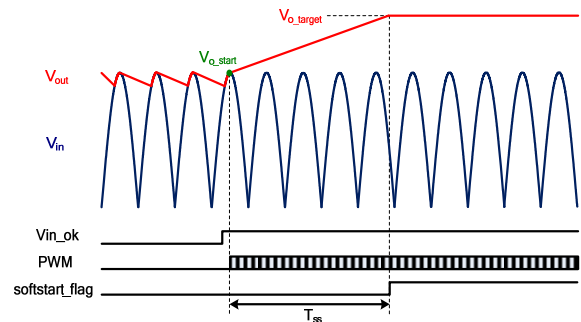

Figure 23: Soft-Start Sequence

The output voltage rises from the rectified output voltage to the target value. When $softstart_flag$ is set high, the soft-start sequence is completed. The soft-start time can be calculated with Equation (19):

$$T_{ss} = (V_{o_target} - V_{o_start}) \cdot \frac{2^{bit_num} - 1}{V_{adc_ref}} \cdot slewrate \quad (19)$$

Where V_{o_target} is the target value of the output voltage, V_{o_start} is the soft-start value of the output voltage, bit_num is the ADC data bit

(typically 12), $V_{\text{adc_ref}}$ is the reference voltage of ADC (typically 1.6V).

The slew rate is different at high line and low line. The slew rate at high line is programmable in register 1Ch. The slew rate at low line is programmable in register 1Dh.

Burst-Mode Operation

In light load, the IC is designed to always run in burst mode for better efficiency and lower no-load power consumption. Once the output load is lower than the threshold (e.g.: 3% rated load), the PFC enters burst mode. The threshold can be programmed in register 2Dh for high line and register 2Fh for low line. In burst mode, the switching duty is calculated based on the 3% rated load. The output is regulated to $V_{\text{o_target}}$ with a 5V hysteresis. The PFC continues switching when the output voltage is below $V_{\text{o_target}} - 5V$. The PFC stops switching when the output voltage ramps up to $V_{\text{o_target}}$.

Generally, the HR1204 is designed to exit burst mode only at the peak point of AC the line to reduce the current stress. Additionally, a threshold voltage that can be programmed in register 0Ah is selectable to prevent the bus voltage from dropping too low under transient condition such as surge. If the bus voltage is lower than the threshold, the IC exits burst mode immediately without waiting for peak point detection.

Burst-mode operation is synchronized with the LLC_sync signal. If the LLC_sync signal is high, the PFC PWM switching is turned off. Once the output voltage is lower than $V_{\text{o_target}} - 5V$, the PFC is turned on again, even if the LLC_sync signal is high. This status continues until the output voltage ramps up to $V_{\text{o_target}}$.

When the PFC recovers from burst mode, it operates in critical conduction mode (CRM) for the first five switching cycles.

Capacitor Current Compensation

Traditional PFC control schemes only regulate the inductor current to match the shape of the input voltage. However, the input capacitor current is not controlled, which may cause PF deterioration and an undesired delay. With a larger capacitor or a higher input voltage, the PF worsens.

To improve the PF, the HR1204 implements a patented method to compensate for PF deterioration. Relevant data are stored in registers 4Bh to 4Eh, corresponding to different input voltage levels. With this function, the PF is improved at all input voltage levels.

Frequency Jittering

To reduce EMI noise, the switching frequency is designed to be modulated by a triangular waveform with the frequency of f_m . The switching frequency is modulated to the maximum value at the peak of the triangle and to the minimum value at the valley of the triangle. Figure 24 shows the algorithm modulating the switching frequency.

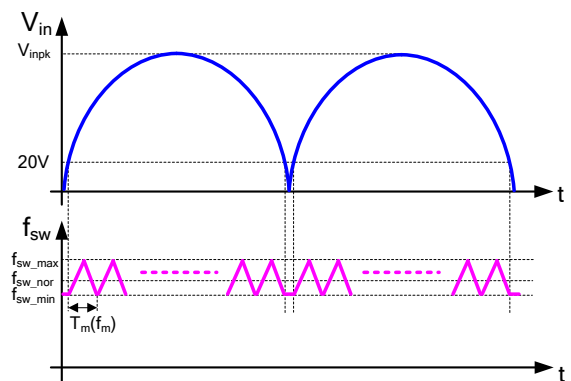

Figure 24: Frequency Jittering

The parameters of $f_{\text{sw_max}}$, $f_{\text{sw_min}}$, and f_m can be programmed by the I²C GUI for the best EMI performance.

PART 4: LLC CONTROLLER

Oscillator (FSET)

Figure 25 shows the block diagram of the oscillator. A modulated current charges and discharges the capacitor on CT. The voltage on the capacitor swings between the peak threshold and the valley threshold to determine the oscillating frequency.

The source current of FSET controls the current source ($I_{\text{S-1}}$) to charge the CT capacitor. Here, the current mirror ratio inside the HR1204 is 1A/A. When an oscillating cycle starts, $I_{\text{S-1}}$ charges the CT capacitor until the voltage triggers the peak threshold voltage. The discharge current source $I_{\text{S-2}}$, which is twice the source current of FSET, is then turned on. Therefore, the CT capacitor is discharged with the source current of FSET. When the voltage

on the CT capacitor drops to the valley threshold voltage, I_{S-2} is turned off, and a new oscillating cycle repeats.

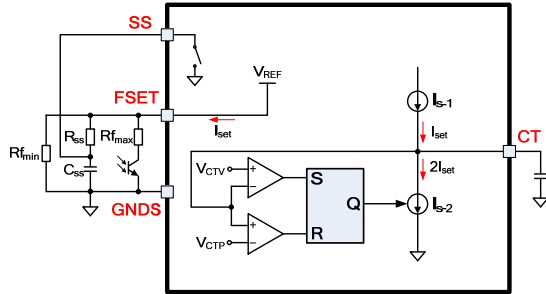

Figure 25: Oscillator Block Diagram

When VCC reaches the turn-on threshold, VREG starts to ramp up. Once VREG exceeds V_{regON} , CT begins to charge, and LSG switches on first. When CT ramps up to V_{CTP} , LSG switches off, and CT holds for a period of dead time. Once the dead time expires, CT drops down, and HSG switches on. HSG keeps working until CT drops down below V_{CTV} , HSG is turned off. A full switching cycle repeats unless VCC is lower than V_{CCUV} . Figure 26 shows the detailed CT waveform from start-up to steady state.

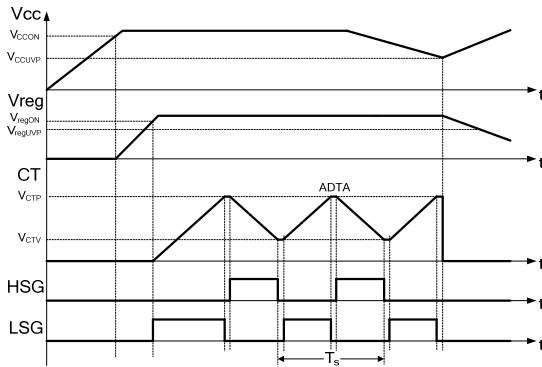

Figure 26: CT Waveform from Start-Up to Steady State

The R-C network connected externally to FSET determines the switching frequency and the soft-start switching frequency.

$R_{f_{min}}$ connected from FSET to GND contributes to the maximum resistance of the external R-C network when the phototransistor is blocked. Therefore, it sets the minimum source current from FSET, which determines the minimum switching frequency.

Under normal operation, the phototransistor controls the current through $R_{f_{max}}$ to modulate

the frequency for output voltage regulation. When the phototransistor is saturated, the current through $R_{f_{max}}$ is at its maximum, thus setting the maximum switching frequency.

An R-C tank connected in series between FSET and GND is used to shift the frequency during start-up (see the Soft Start section for details).

The operation period can be expressed with Equation (20):

$$f_s = \frac{1}{3 \cdot CT \cdot R_{FSET}} \quad (20)$$

Where R_{FSET} represents the total equivalent resistor on FSET.

The minimum and maximum frequency can be calculated with Equation (21) and Equation (22):

$$f_{min} = \frac{1}{3 \cdot CT \cdot R_{f_{min}}} \quad (21)$$

$$f_{max} = \frac{1}{3 \cdot CT \cdot (R_{f_{min}} \parallel R_{f_{max}})} \quad (22)$$

The values of $R_{f_{min}}$ and $R_{f_{max}}$ can be extracted with Equation (23) and Equation (24):

$$R_{f_{min}} = \frac{1}{3 \cdot CT \cdot f_{min}} \quad (23)$$

$$R_{f_{max}} = \frac{R_{f_{min}}}{\frac{f_{max}}{f_{min}} - 1} \quad (24)$$

Soft Start (SS)

For the resonant half-bridge converter, the power delivered is inversely proportional to the switching frequency. To ensure that the converter starts or restarts safely, the soft-start function sets the switching frequency at a high value until the value is controlled by the closed loop. The soft start can be achieved easily using an external R-C series circuit.

At the beginning of the start-up sequence, the SS voltage is 0V. The soft-start resistor (R_{SS}) is parallel with $R_{f_{min}}$. $R_{f_{min}}$ and R_{SS} determine the initial frequency with Equation (25):

$$f_{start} = \frac{1}{3 \cdot CT \cdot (R_{f_{min}} \parallel R_{SS})} \quad (25)$$

During start-up, C_{SS} is charged until its voltage reaches the reference (V_{REF}), and the current flowing through R_{SS} drops to zero. This period

takes about $5R_{SS}C_{SS}$. During this period, the switching frequency changes following an exponential curve. Initially, the C_{SS} charging process decays relatively quickly, but the rate slows progressively. After this period, the output voltage is still not close to the setting value, so the feedback loop takes over after start-up. With a soft-start function, the input current increases gradually until the output voltage reaches the setting point with little overshoot.

The parameters of the soft-start R-C network can be chosen according to Equation (26) and Equation (27):

$$R_{SS} = \frac{Rf_{min}}{f_{start} - 1} \quad (26)$$

$$C_{SS} = \frac{3 \times 10^{-3}}{R_{SS}} \quad (27)$$

Select the initial frequency (f_{start}) to be at least four times the minimum value (f_{min}). When selecting C_{SS} , there is a trade-off between the desired soft-start operation and the OCP speed.

Adaptive Dead-Time Adjustment (HBVS)

A dead-time period between the HSG and LSG drivers is always needed in half-bridge topologies to prevent cross-conduction through the power stage MOSFETs, which may result in excessive current, high EMI noise, and destruction in practical applications. Traditional fixed dead-time control schemes are often used in resonant converters since it is simple to implement. However, this method can cause hard switching in light load or a large L_m design condition, which eventually leads to thermal and reliability issues.

The HR1204 incorporates an intelligent ADTA logic circuit, which is capable of detecting the dV/dt of SW and inserting a proper dead-time automatically with respect to the actual operating conditions of the converter. To achieve this, a 5pF high-voltage capacitor is recommended between SW and HBVS. With ADTA, the MOSFET body diode conduction time can be minimized, which enables the LLC converter to achieve high efficiency from light load to full load due to ZVS. Moreover, the design of thermal management and L_m of the

transformer can be easier. Figure 27 shows the simplified block diagram of ADTA.

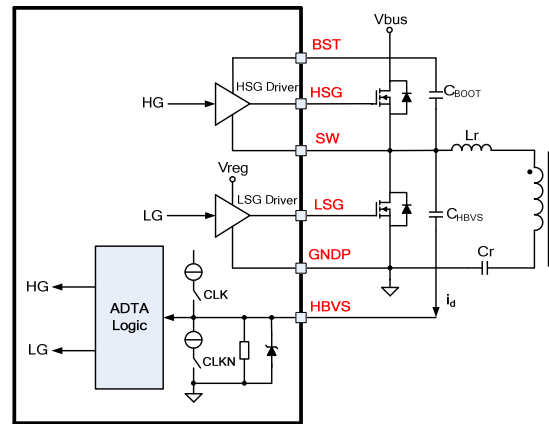

Figure 27: Block Diagram of ADTA

Once HSG switches off, SW begins swinging from a high voltage to a low voltage due to the resonant tank current (I_r). A negative dV/dt draws a current from HBVS via C_{HBVS} . HBVS is pulled down depending on dV/dt and C_{HBVS} . If the differential current is higher than the internal comparator current, HBVS is pulled down to zero and clamped. When SW stops slewing, the differential current elapses accordingly. HBVS starts to ramp up. LSG switches on after a minimum dead time.

Dead time is the duration from the time HSG switches off to the time LSG switches on and relies on the completion of SW's transition.

When LSG switches off, SW swings from zero to high, creating a positive differential current via C_{HBVS} . The dead time adjusts automatically.

To avoid damaging HBVS, the differential current should not be higher than 65mA. Otherwise, a smaller value for C_{HBVS} must be selected to meet Equation (28):

$$i_d = \left| C_{HBVS} \cdot \frac{dv}{dt} \right| < 65mA \quad (28)$$

However, if the value of C_{HBVS} is too small to detect dV/dt , the minimum voltage change rate (dv_{min}/dt) is taken into account to choose an appropriate C_{HBVS} .

First, calculate the peak magnetizing current (I_m) according to Equation (29):

$$I_m = \frac{V_{in}}{8 \cdot L_m \cdot f_{max}} \quad (29)$$

Then C_{HBVS} can be designed with Equation (30):

$$C_{HBVS} > \frac{950 \mu A}{I_m} \cdot \frac{C_{OSS}}{2} \quad (30)$$

Where C_{OSS} is the output capacitance of the power stage MOSFET when V_{DS} equals zero. For a typical design, $L_m = 870\mu H$, $V_{IN} = 450Vdc$, and $f_{max} = 140kHz$. Based on the calculated results, C_{HBVS} should be larger than 4.5pF. 5pF is sufficient for most MOSFETs, typically.

Figure 28 shows the operation waveform of ADTA. Figure 29 illustrates the possible dead time with ADTA logic. There are three kinds of possible dead time: minimum dead time (t_{DMIN}) (typically 240ns), maximum dead time (t_{DMAX}) (typically 1.1 μs), and adjusted dead time (between t_{DMIN} and t_{DMAX}). When the transition time of SW is smaller than t_{DMIN} , the logic prevents the gate from providing output until t_{DMIN} is reached. This can avoid any shoot-through of the high-side and low-side MOSFET. If the dead time is too long, duty cycle loss and soft switching loss may result. Therefore, a maximum dead time (t_{DMAX}) is set to force the gate to switch on.

If HBVS is shorted to GND, LLC stops switching. If HBVS is floating, the internal circuit cannot detect the differential current in HBVS, and the fixed dead time (300ns) takes effect.

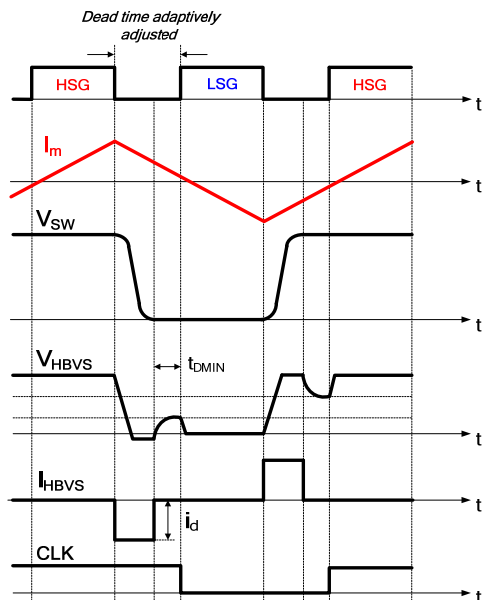

Figure 28: Operation Waveform of ADTA

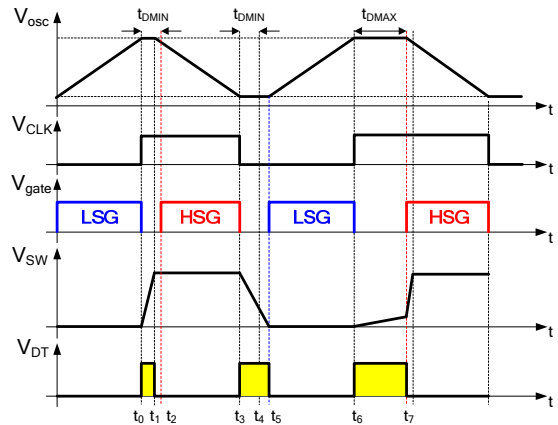

Figure 29: Dead Time in ADTA

Capacitive Mode Protection (CMP, CSHB)

In fault conditions such as overload or short-circuit condition, the converter may run into the capacitive region. In capacitive mode, the voltage applied to the resonant tank lags off the current. The body diode of one of the MOSFETs switches on. To avoid device damage, the switching of the other MOSFET should be blocked. The functional block diagram of CMP is shown in Figure 30.

Figure 31 shows the operating principle of capacitive mode protection. CSPOS and CSNEG stand for the current polarity, which is generated by comparing the voltage of CS with internal +80mV and -80mV voltage reference.

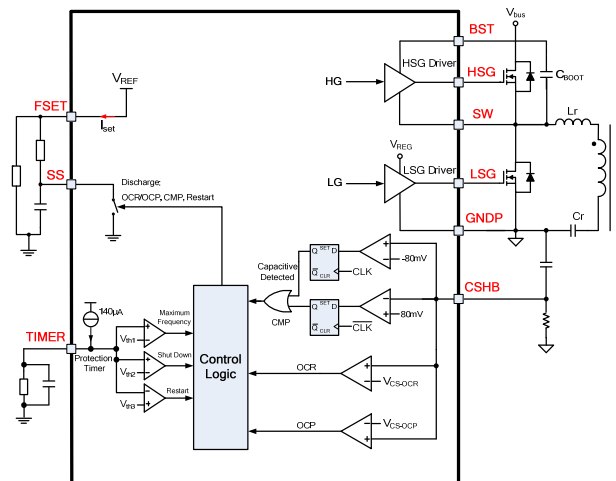
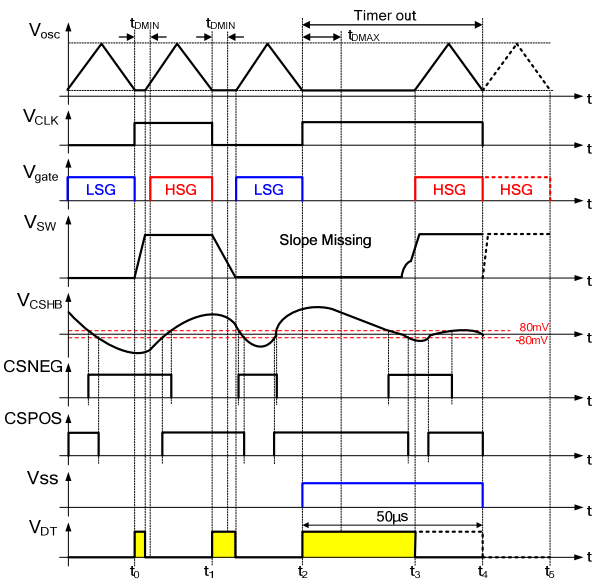

Figure 30: CMP and OCP Block Diagram

Figure 31: Operating Principle of CMP

At t_0 , the low-side gate driver switches off for the first time. CSNEG is high, which means the current is at the correct polarity, so the converter is operating in inductive mode. The capacitive mode protection circuit is not active.

At t_1 , the high-side gate driver switches off for the first time. CSPOS is high, so the current is at the correct polarity, and the converter operates in inductive mode. The capacitive mode protection circuit is still not active.

At t_2 , the low-side gate driver turns off for a second time. CSNEG is zero and CSPOS is high, which means the converter is operating in capacitive mode. The body diode of the low-side MOSFET takes over the current after the low-side MOSFET turns off. SW does not turn high, so HBVS cannot catch the dV/dt until the current returns to the correct polarity. The dead time remains high, and VCO is held. Another MOSFET does not switch on. So, capacitive switching is prevented effectively.

At t_3 , the current returns to the correct polarity, then another MOSFET is turned on due to dV/dt being captured.

If the right current polarity cannot be detected from t_2 to t_4 , or the current is very small and is not capable of pulling SW up or down, eventually another MOSFET is forced to switch on when the timer for CMP ($50\mu s$) expires (see the dashed lines in Figure 31).

The V_{SS} control signal controls the soft start. When capacitive mode operation is detected, V_{SS} is high. An internal MOSFET is turned on to pull the voltage of C_{SS} low. Therefore, the switching frequency increases quickly to limit the power delivered to the output. V_{SS} is reset when the first gate driver is turned off (after CMP). The switching frequency decreases smoothly until the control loop takes over.

Over-Current Regulation and Over-Current Protection (CSHB, TIMER)

The HR1204 provides two levels of over-current protection (see Figure 32).

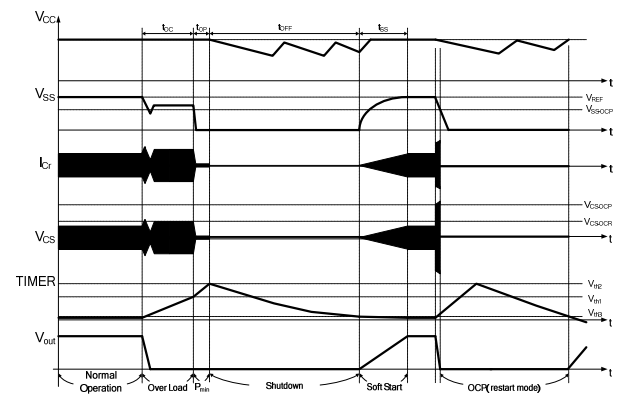
Figure 32: OCR Timing Sequence

1. Over-current regulation:

The first level of protection occurs when the voltage on CSHB exceeds V_{CS-OCR} ($0.77V$). When this occurs, the transistor connected internally between SS and GND is turned on for at least $10\mu s$, which causes the C_{SS} voltage to drop down, resulting in a sharp increase in the oscillator frequency. Hence, the energy transferred to the output is reduced. An internal $140\mu A$ current source is turned on to charge C_{TIMER} and raises the voltage of TIMER. If the CSHB voltage drops below V_{CS-OCR} ($10mV$ hysteresis) before the TIMER voltage reaches V_{th1} ($1.97V$), the discharging of C_{SS} and the charging of C_{TIMER} stop. Then the converter resumes normal operation.

t_{OC} represents the time for the C_{TIMER} voltage to rise from $0V$ to V_{th1} . This is actually a delay time for over-current regulation. There is no simple relationship between t_{OC} and C_{TIMER} . C_{TIMER} is selected based on experimental results.

If the CSHB voltage remains larger than V_{CS-OCR} after the TIMER voltage reaches V_{th1} , C_{SS} is

discharged completely. Simultaneously, the internal 140µA current source continues charging C_{TIMER} until the TIMER voltage reaches V_{th2} (3.45V). At this time, the IC turns off all gate driver outputs.

The period for the TIMER voltage to rise from V_{th1} to V_{th2} can be calculated approximately by using Equation (31):

$$t_{OP} = 10^4 \cdot C_{TIMER} \quad (31)$$

The above status remains until V_{TIMER} drops to V_{th3} (0.29V) as C_{TIMER} is discharged slowly by R_{TIMER} . The IC then restarts. The time period can be calculated using Equation (32):

$$t_{OFF} = \ln \frac{V_{th2}}{V_{th3}} \cdot R_{TIMER} C_{TIMER} \approx 2.5 \cdot R_{TIMER} C_{TIMER} \quad (32)$$

The OCR limits the energy transferred from the primary to the secondary winding during overload or short-circuit period. However, excessive power consumption due to high continuous currents can damage the secondary-side windings and the rectifiers. By incorporating the TIMER function, the IC provides additional protection to reduce the average power consumption. When OCR is triggered, the converter enters a hiccup-like protection mode that operates intermittently. Figure 32 shows the timing procedure.

2. Over-current protection:

The second level of protection is triggered when $V_{CS} > V_{CS-OC}$ (1.48V). Normally, this condition occurs when the CSHB voltage continues rising during the short-circuit period. Once V_{CS} rises to V_{CS-OC} , the IC does not stop switching immediately until $V_{SS} < V_{SS-OC}$, and C_{SS} is discharged by an internal transistor continuously. If V_{CS} remains above V_{CS-OC} until V_{SS} drops below V_{SS-OC} , the IC shuts down. C_{TIMER} is charged by an internal 140µA current source until the TIMER voltage reaches V_{th2} . The IC resumes operation if the TIMER voltage falls below V_{th3} .

The OCP provides a high-speed over-current limitation. The IC works in auto-recovery mode when OCP triggers.

Current Sensing

The HR1204 uses two methods for sensing current: lossless current sensing and sense resistor current sensing. Generally, lossless

current sensing is used in high-power applications (see Figure 33).

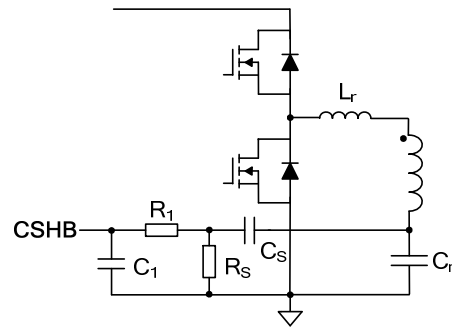

Figure 33: Current Sensing with Lossless Network

To design a lossless current sensing network, Equation (33) should be satisfied:

$$C_s \leq \frac{C_r}{100} \quad (33)$$

R_s should satisfy Equation (34):

$$R_s < \frac{V_{CS-OCR}}{I_{Crpk}} \cdot \left(1 + \frac{C_r}{C_s}\right) \quad (34)$$

Where I_{Crpk} is the peak current of the resonant tank at a low input voltage and full load.

I_{Crpk} can be expressed in Equation (35):

$$I_{Crpk} = \sqrt{\left(\frac{NV_o}{4L_m f_s}\right)^2 + \left(\frac{I_o \pi}{2N}\right)^2} \quad (35)$$

Where N is the turn ratio of the transformer, I_o is the output current, V_o is the output voltage, f_s is the switching frequency, and L_m is the magnetizing inductance.

For capacitive mode detection in no-load or tiny-load condition, R_s should meet Equation (36):

$$R_s > \frac{80 \text{ mV}}{I_m} \cdot \left(1 + \frac{C_r}{C_s}\right) \quad (36)$$

In some conditions, especially when a large L_m is used, it is difficult to meet Equation (34) and Equation (36) simultaneously. The system operates without the CMP function at light load if Equation (36) is not satisfied.

The R_1 and C_1 network is used to attenuate the switching noise on CSHB. The time constant should be no larger than 100ns.

An alternative solution is to use a sense resistor in series with the resonant tank (see Figure 34). This method is quite simple, but may cause undesired power consumption on the sense resistor.

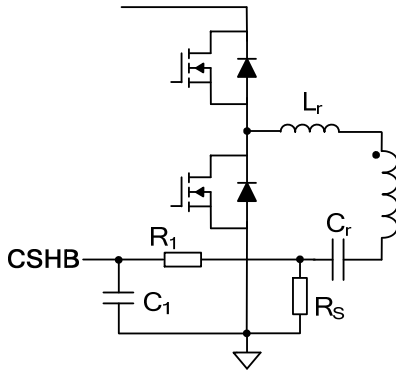

Figure 34: Current Sensing with a Sense Resistor

The sense resistor can be designed using Equation (37):

$$R_s < \frac{V_{CS-OCR}}{I_{Crpk}} \quad (37)$$

LLC Brown-In/Brown-Out (D2D_BI/BO)

The LLC controller stops when the D2D_BI/BO signal is low and recovers once the D2D_BI/BO signal goes high.

Burst-Mode Operation (BURST)

Under light-load or no-load condition, the resonant half-bridge switching frequency is limited by the system maximum frequency. To control the output voltage and limit the power consumption, the HR1204 enables the converter to operate in burst mode to reduce the average switching frequency, reducing the average residual magnetizing current and related power losses.

Figure 35 shows a typical circuit connecting BURST to the feedback signal. R_{BURST} and C_{BURST} must be optimized to adjust the number of switching cycles during the burst-on period, which can reduce no-load power consumption. R_{fmax} can determine the maximum switching frequency, which is needed for the IC to operate in burst mode and determines the level of output load needed to run in burst mode.

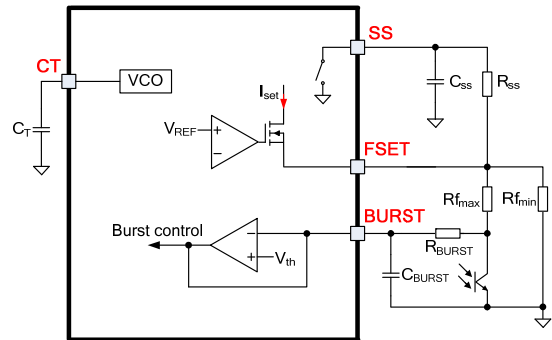

Figure 35: Burst-Mode Operation Set-Up

Figure 36 illustrates the burst-mode operation waveforms. When the output load decreases, the BURST voltage also decreases. If the BURST voltage drops below V_{th} (1.23V), the HR1204 stops switching both the HSG and LSG and connects CT to GND internally. Meanwhile, the SYN signal is set high. It is used to synchronize the burst of PFC and LLC. Once the voltage on BURST exceeds V_{th} by a hysteresis of 40mV, the HR1204 resumes normal operation and the SYN signal is set low. During burst-mode operation, VREG normally holds above V_{regUVP} , and the soft-start function is not activated.

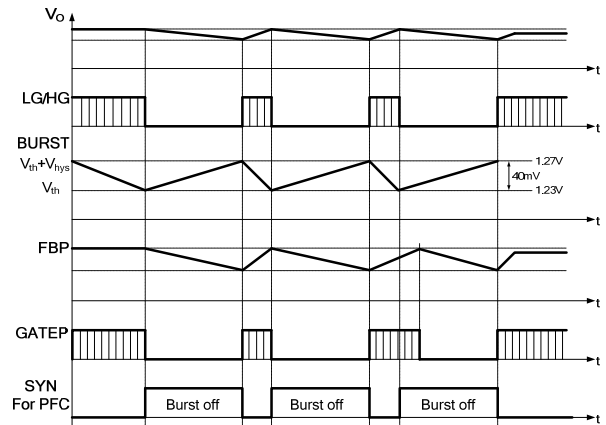

Figure 36: Burst-Mode Operation

Latch Protection (SO)

If the SO voltage exceeds the threshold ($V_{SO-Latch}$) (3.42V), the IC latches off. This status can only be released when VCC drops below V_{CCRST} . This function can be used for OVP or OTP.

Start-Up Failure Protection (SFP, SO)

The HR1204 provides a one-shot start-up failure protection by sampling the SO voltage.

Figure 37 shows the detailed SFP timing.

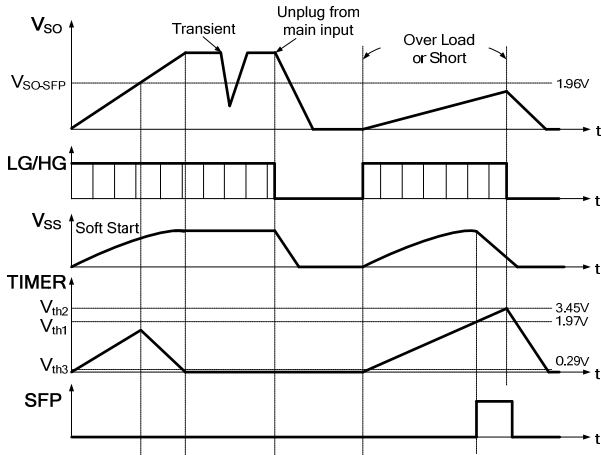

Figure 37: SFP Timing

During start-up, the TIMER capacitor starts charging up via an internal 25 μ A current source. If the SO voltage is less than V_{SO-SFP} (1.96V) when the TIMER voltage rises up to V_{th1} , then the IC treats this as a fault condition. The HR1204 begins discharging the SS capacitor, and TIMER continues ramping up irreversibly. Once the TIMER voltage reaches V_{th2} , the HR1204 stops charging TIMER, and both PFC and LLC stop switching. Since there is a resistor in parallel with the TIMER capacitor, the TIMER voltage is pulled down gradually. The IC attempts another start-up sequence until the TIMER voltage falls below V_{th3} .

Connect SO to the resistor divider from V3.3 if the SO function is not needed.

High-Side Gate Driver (HSG)

The external BST capacitor provides energy to the high-side gate driver. An integrated bootstrap diode charges this capacitor through VCC. This diode simplifies the external driving circuit for the high-side switch, allowing the BST capacitor to be charged when the low-side MOSFET is on.

Considering the BST capacitor charging time, to provide enough gate driver energy, a BST capacitor of 100nF to 1 μ F is recommended

(see Figure

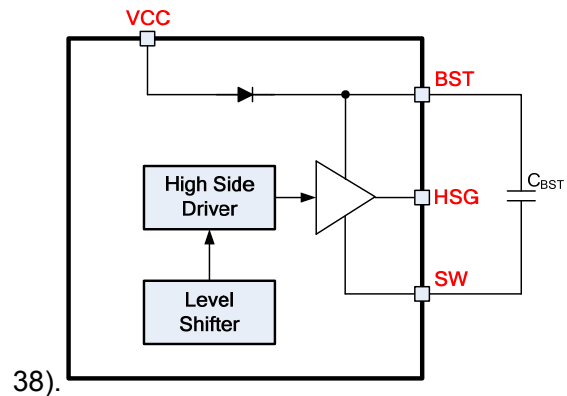

38).

Figure 38: High-Side Gate Driver

Low-Side Gate Driver (LSG)

LSG provides the gate driver signal for the low-side MOSFET. The Maximum Absolute Ratings table on page 5 shows the maximum LSG voltage is 14V. Under certain conditions, such as the surge rating being too high), a large voltage spike may occur on the LSG due to oscillations from the long gate-driver wire, the MOSFET parasitic capacitance, and the small gate-driver resistor. The voltage spike may cause damage to LSG. Although there is suppression internally in the chip, it is better to add a 13V Zener diode close to LSG and GND to prevent damage to the chip pins (see Figure 39).

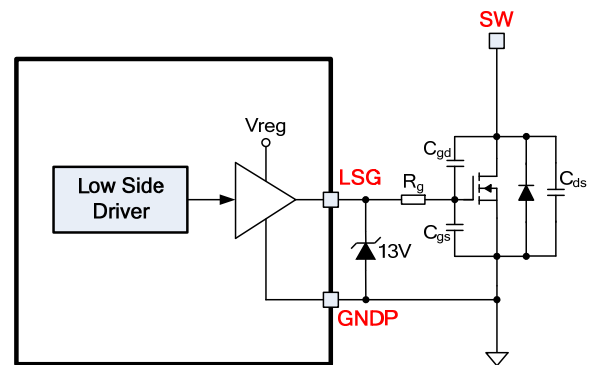
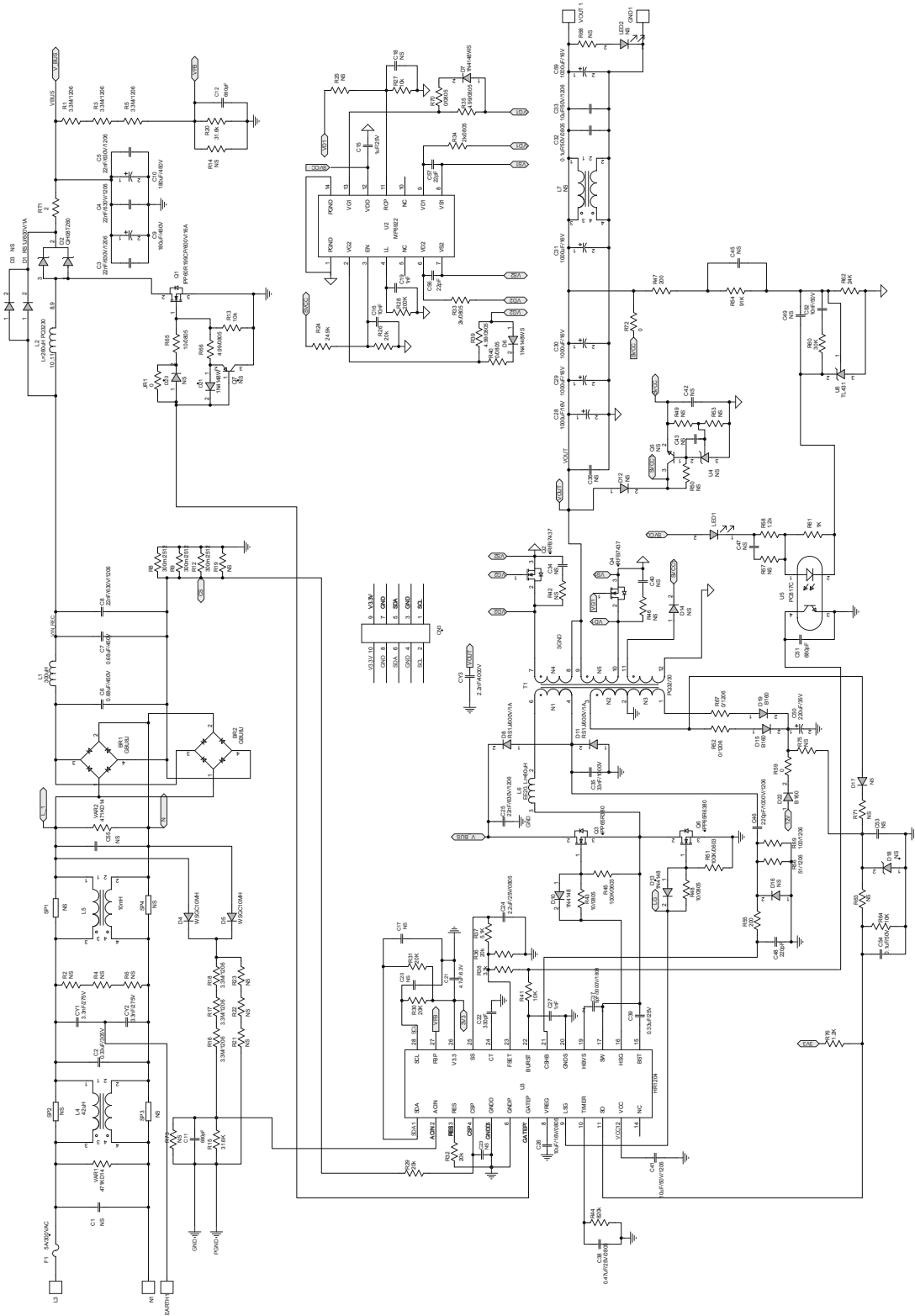
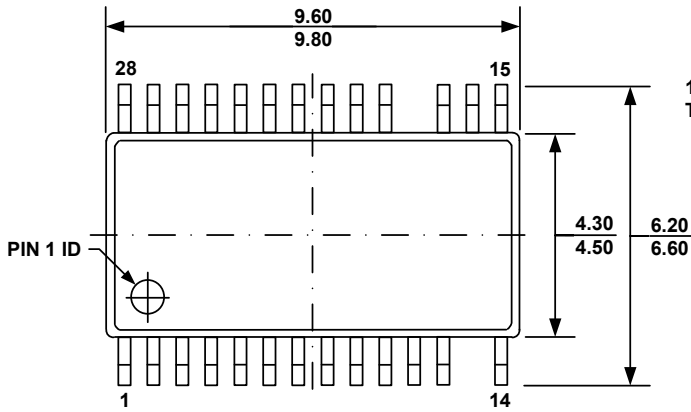
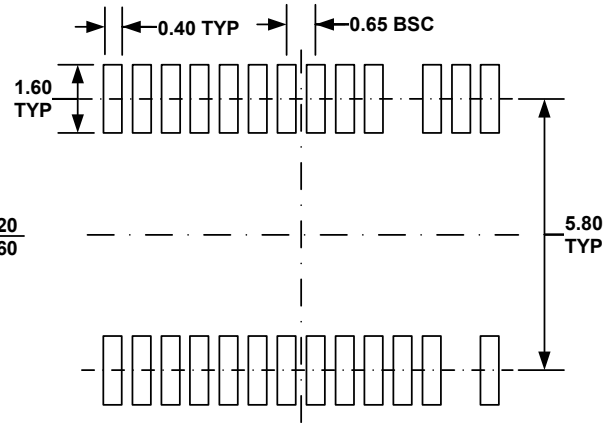
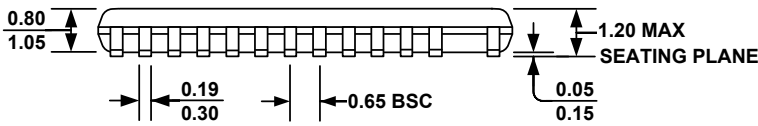
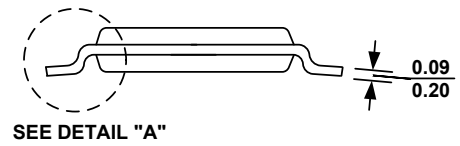
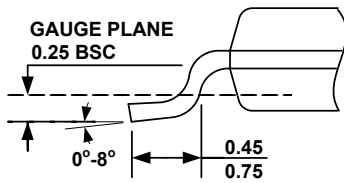

Figure 39: Low-Side Gate Driver

PROTECTION SUMMARY

Pin	Symbol	Description	Affected	Action
VCC	V_{CCUVP}	Under-voltage protection for VCC	System	Disable
VCC	V_{CCSCP}	Short-circuit protection for VCC	System	Disable
VREG	V_{regUVP}	Under-voltage protection for VREG	System	Disable and limit I_{Ch}
SO	$V_{SO-Latch}$	Latch protection	System	Shutdown and latch
SO	V_{SO-SFP}	Start-up failure protection	System	Restart with timer out
	OTP	Over-temperature protection	System	Disable
ACIN	Brown-out	Line input under-voltage protection	System	Suspend switching
CSP	OCP_PFC	Current limit of PFC	PFC	Program with restart or latch off
FBP	OVP_PFC	Over-voltage protection for PFC	PFC	Suspend switching
FBP	OLP_PFC	Open-loop protection	System	Restart with recovery
FBP	UVP_PFC	Under-voltage protection for PFC	HBC	Suspend switching
	LLC brown-in/-out	LLC stage under-voltage protection	HBC	Suspend switching
CSHB	OCR_HBC	Over-current regulation for HBC	HBC	Restart with timer out
CSHB	OCP_HBC	Over-current protection for HBC	HBC	Shutdown, restart with timer out
CSHB	CMR	Capacitive mode regulation	HBC	Increasing switching frequency
CSHB	ADT	Adaptive dead time	HBC	Prevent hard switching

TYPICAL APPLICATION CIRCUIT

Figure 40: Application Circuit

PACKAGE INFORMATION
TSSOP28

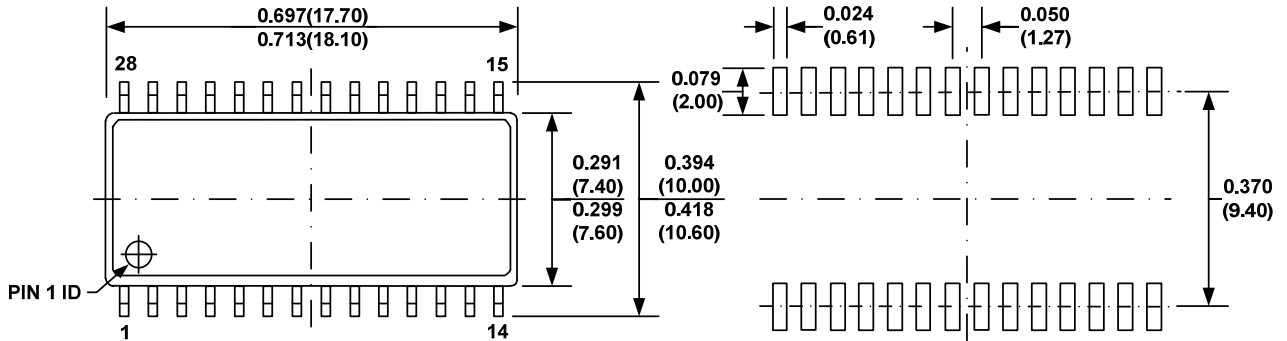
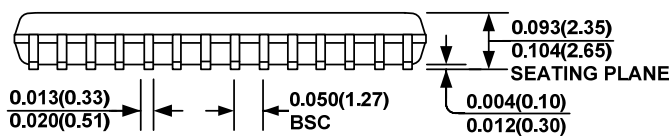
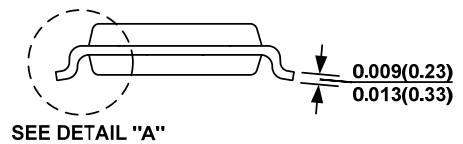
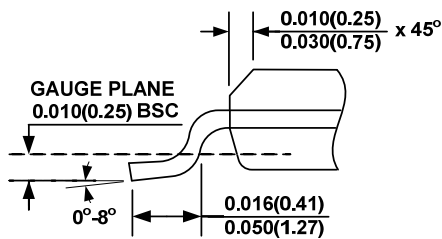
TOP VIEW

RECOMMENDED LAND PATTERN

FRONT VIEW

SIDE VIEW

DETAIL "A"
NOTE:

- 1) ALL DIMENSIONS ARE IN MILLIMETERS.
- 2) PACKAGE LENGTH DOES NOT INCLUDE MOLD FLASH, PROTRUSION OR GATE BURR.
- 3) PACKAGE WIDTH DOES NOT INCLUDE INTERLEAD FLASH OR PROTRUSION.
- 4) LEAD COPLANARITY (BOTTOM OF LEADS AFTER FORMING) SHALL BE 0.10 MILLIMETERS MAX.
- 5) DRAWING CONFORMS TO JEDEC MO-153, VARIATION AE.
- 6) DRAWING IS NOT TO SCALE.

PACKAGE INFORMATION (continued)
SOIC-28

TOP VIEW
RECOMMENDED LAND PATTERN

FRONT VIEW

SIDE VIEW

DETAIL "A"
NOTE:

- 1) CONTROL DIMENSION IS IN INCHES. DIMENSION IN BRACKET IS IN MILLIMETERS.
- 2) PACKAGE LENGTH DOES NOT INCLUDE MOLD FLASH, PROTRUSIONS OR GATE BURRS.
- 3) PACKAGE WIDTH DOES NOT INCLUDE INTERLEAD FLASH OR PROTRUSIONS.
- 4) LEAD COPLANARITY (BOTTOM OF LEADS AFTER FORMING) SHALL BE 0.10 MILLIMETERS MAX.
- 5) DRAWING CONFORMS TO JEDEC MS-013, VARIATION AE.
- 6) DRAWING IS NOT TO SCALE.

APPENDIX A: I²C COMMANDS AND REGISTERS

VOUT_CMD_H (02/01h, 10 bits)

Sets the normal value of the output voltage target at high line. The default setting for the -0001 version is 1100011110.

Command	VOUT_CMD_H															
Bit	15	14	13	12	11	10	9	8	7	6	5	4	3	2	1	0
Access	r	r	r	r	r	r	r/w	r/w	r/w	r/w	r/w	r/w	r/w	r/w	r/w	r/w

VOUT_CMD_L (04/03h, 10 bits)

Sets the normal value of the output voltage target at low line. The default setting for the -0001 version is 1100011110.

Command	VOUT_CMD_L															
Bit	15	14	13	12	11	10	9	8	7	6	5	4	3	2	1	0
Access	r	r	r	r	r	r	r/w	r/w	r/w	r/w	r/w	r/w	r/w	r/w	r/w	r/w

VIN_HL_LINE (05h, 8 bits)

Sets the threshold of the high line and low line. The default setting for the -0001 version is 01110001.

Command	VIN_HL_LINE							
Bit	7	6	5	4	3	2	1	0
Access	r/w	r/w	r/w	r/w	r/w	r/w	r/w	r/w

AUTO_VOUT_VCOMP1 (07/06h, 14 bits)

Sets the Load Level 1 of the auto-output voltage. The default setting for the -0001 version is 00011111111100.

Command	AUTO_VOUT_VCOMP1															
Bit	15	14	13	12	11	10	9	8	7	6	5	4	3	2	1	0
Access	r	r	r/w	r/w	r/w	r/w	r/w	r/w	r/w	r/w	r/w	r/w	r/w	r/w	r/w	r/w

AUTO_VOUT_VCOMP2 (09/08h, 14 bits)

Sets the Load Level 2 of the auto-output voltage. The default setting for the -0001 version is 00001100110010.

Command	AUTO_VOUT_VCOMP2															
Bit	15	14	13	12	11	10	9	8	7	6	5	4	3	2	1	0
Access	r	r	r/w	r/w	r/w	r/w	r/w	r/w	r/w	r/w	r/w	r/w	r/w	r/w	r/w	r/w

BURST_VOUT_LIMIT (0Ah, 5 bits)

Sets the threshold voltage of exiting burst mode. The default setting for the -0001 version is 10111.

Command	BURST_VOUT_LIMIT							
Bit	7	6	5	4	3	2	1	0
Access	r	r	r	r/w	r/w	r/w	r/w	r/w

AUTO_VOUT_CMPHYS (0D/0Ch, 14 bits)

Sets the load hysteresis of the auto-output voltage. The default setting for the -0001 version is 00000011110101.

Command	AUTO_VOUT_CMPHYS															
Bit	15	14	13	12	11	10	9	8	7	6	5	4	3	2	1	0
Access	r	r	r/w	r/w	r/w	r/w	r/w	r/w	r/w	r/w	r/w	r/w	r/w	r/w	r/w	r/w

AUTO_VOUTH_CMD1_L (0Eh, 8 bits)

Sets the low byte of the output voltage level one at high line. The default setting for the -0001 version is 00011110.

Command	AUTO_VOUTH_CMD1_L							
Bit	7	6	5	4	3	2	1	0
Access	r/w	r/w	r/w	r/w	r/w	r/w	r/w	r/w

AUTO_VOUTH_CMD2_L (0Fh, 8 bits)

Sets the low byte of the output voltage level two at high line. The default setting for the -0001 version is 00011110.

Command	AUTO_VOUTH_CMD2_L							
Bit	7	6	5	4	3	2	1	0
Access	r/w	r/w	r/w	r/w	r/w	r/w	r/w	r/w

AUTO_VOUTH_CMD_H (11h, 4 bits)

Sets the high byte of the output voltage at high line. The default setting for the -0001 version is 1111.

Bit	Item	Description
3:2	AUTO_VOUTH_CMD2_H	High bits of output voltage level two at high line.
1:0	AUTO_VOUTH_CMD1_H	High bits of output voltage level one at high line.

Command	AUTO_VOUTH_CMD_H							
Bit	7	6	5	4	3	2	1	0
Access	r	r	r	r	r/w	r/w	r/w	r/w

AUTO_VOUTL_CMD1_L (12h, 8 bits)

Sets the low byte of the output voltage level one at low line. The default setting for the -0001 version is 00011110.

Command	AUTO_VOUTL_CMD1_L							
Bit	7	6	5	4	3	2	1	0
Access	r/w	r/w	r/w	r/w	r/w	r/w	r/w	r/w

AUTO_VOUTL_CMD2_L (13h, 8 bits)

Sets the low byte of the output voltage level two at low line. The default setting for the -0001 version is 00011110.

Command	AUTO_VOUTL_CMD2_L							
Bit	7	6	5	4	3	2	1	0
Access	r/w	r/w	r/w	r/w	r/w	r/w	r/w	r/w

AUTO_VOUTL_CMD_H (15h, 4 bits)

Sets the high byte of the output voltage at low line. The default setting for the -0001 version is 111111.

Bit	Item	Description
3:2	AUTO_VOUTL_CMD2_H	High bits of output voltage level two at low line.
1:0	AUTO_VOUTL_CMD1_H	High bits of output voltage level one at low line.

Command	AUTO_VOUTL_CMD_H							
Bit	7	6	5	4	3	2	1	0
Access	r	r	r	r	r/w	r/w	r/w	r/w

LLC_ENABLE_HIGH (17/16h, 10 bits)

Sets the enable threshold voltage of the LLC. The default setting for the -0001 version is 1100101010.

Command	LLC_ENABLE_HIGH															
Bit	15	14	13	12	11	10	9	8	7	6	5	4	3	2	1	0
Access	r	r	r	r	r	r	r/w	r/w	r/w	r/w	r/w	r/w	r/w	r/w	r/w	r/w

LLC_ENABLE_LOW (19/18h, 10 bits)

Sets the disable threshold voltage of the LLC. The default setting for the -0001 version is 1001010001.

Command	LLC_ENABLE_LOW															
Bit	15	14	13	12	11	10	9	8	7	6	5	4	3	2	1	0
Access	r	r	r	r	r	r	r/w	r/w	r/w	r/w	r/w	r/w	r/w	r/w	r/w	r/w

ZCD_PERIOD_H (1Ah, 7 bits)

Sets the oscillation period of the turn-off current at high line. The default setting for the -0001 version is 0010100.

Command	ZCD_PERIOD_H							
Bit	7	6	5	4	3	2	1	0
Access	r	r/w	r/w	r/w	r/w	r/w	r/w	r/w

ZCD_PERIOD_L (1Bh, 7 bits)

Sets the oscillation period of the turn-off current at low line. The default setting for the -0001 version is 0101000.

Command	ZCD_PERIOD_L							
Bit	7	6	5	4	3	2	1	0
Access	r	r/w	r/w	r/w	r/w	r/w	r/w	r/w

SLEWRATE_HIGH (1Ch, 8 bits)

Sets the soft-start slew rate at high line. The default setting for -0001 version is 00000110.

Command	SLEWRATE_HIGH							
Bit	7	6	5	4	3	2	1	0
Access	r/w	r/w	r/w	r/w	r/w	r/w	r/w	r/w

SLEWRATE_LOW (1Dh, 8 bits)

Sets the soft-start slew rate at low line. The default setting for the -0001 version is 00001101.

Command	SLEWRATE_LOW							
Bit	7	6	5	4	3	2	1	0
Access	r/w	r/w	r/w	r/w	r/w	r/w	r/w	r/w

TS1_L (1Eh, 8 bits)

Sets the low byte of the switching period at level one of the input voltage. The default setting for the -0001 version is 11001000.

Command	TS1_L							
Bit	7	6	5	4	3	2	1	0
Access	r/w	r/w	r/w	r/w	r/w	r/w	r/w	r/w

TS2_L (1Fh, 8 bits)

Sets the low byte of the switching period at level two of the input voltage. The default setting for the -0001 version is 11001000.

Command	TS2_L							
Bit	7	6	5	4	3	2	1	0
Access	r/w	r/w	r/w	r/w	r/w	r/w	r/w	r/w

TS3_L (20h, 8 bits)

Sets the low byte of the switching period at level three of the input voltage. The default setting for the -0001 version is 11001000.

Command	TS3_L							
Bit	7	6	5	4	3	2	1	0
Access	r/w	r/w	r/w	r/w	r/w	r/w	r/w	r/w

TS4_L (21h, 8 bits)

Sets the low byte of the switching period at level four of the input voltage. The default setting for the -0001 version is 10100111.

Command	TS4_L							
Bit	7	6	5	4	3	2	1	0
Access	r/w	r/w	r/w	r/w	r/w	r/w	r/w	r/w

TS_H (22h, 4 bits)

Sets the high byte of the switching period. The default setting for the -0001 version is 0000.

Bit	Item	Description
3	TS4_H	High bit of the switching period at level four of the input voltage.
2	TS3_H	High bit of the switching period at level three of the input voltage.
1	TS2_H	High bit of the switching period at level two of the input voltage.
0	TS1_H	High bit of the switching period at level one of the input voltage.

Command	TS_H							
Bit	7	6	5	4	3	2	1	0
Access	r	r	r	r	r/w	r/w	r/w	r/w

TS_MIN1_L (23h, 8 bits)

Sets the low byte of the maximum switching period at level one of the input voltage. The default setting for the -0001 version is 00100000.

Command	TS_MIN1_L							
Bit	7	6	5	4	3	2	1	0
Access	r/w	r/w	r/w	r/w	r/w	r/w	r/w	r/w

TS_MIN2_L (24h, 8 bits)

Sets the low byte of the maximum switching period at level two of the input voltage. The default setting for the -0001 version is 00100000.

Command	TS_MIN2_L							
Bit	7	6	5	4	3	2	1	0
Access	r/w	r/w	r/w	r/w	r/w	r/w	r/w	r/w

TS_MIN3_L (25h, 8 bits)

Sets the low byte of the maximum switching period at level three of the input voltage. The default setting for the -0001 version is 00100000.

Command	TS_MIN3_L							
Bit	7	6	5	4	3	2	1	0
Access	r/w	r/w	r/w	r/w	r/w	r/w	r/w	r/w

TS_MIN4_L (26h, 8 bits)

Sets the low byte of the maximum switching period at level four of the input voltage. The default setting for the -0001 version is 11110100.

Command	TS_MIN4_L							
Bit	7	6	5	4	3	2	1	0
Access	r/w	r/w	r/w	r/w	r/w	r/w	r/w	r/w

TS_MIN_H (27h, 8 bits)

Sets the high byte of the maximum switching period. The default setting for the -0001 version is 01111111.

Bit	Item	Description
7:6	TS_MIN4_H	High bit of the maximum switching period at level four.
5:4	TS_MIN3_H	High bit of the maximum switching period at level three.
3:2	TS_MIN2_H	High bit of the maximum switching period at level two.
1:0	TS_MIN1_H	High bit of the maximum switching period at level one.

Command	TS_MIN_H							
Bit	7	6	5	4	3	2	1	0
Access	r/w	r/w	r/w	r/w	r/w	r/w	r/w	r/w

JITTER_AMPLITUDE (28h, 8 bits)

Sets the peak-to-peak amplitude of the switching frequency jitter. The default setting for the -0001 version is 00000010.

Command	JITTER_AMPLITUDE							
Bit	7	6	5	4	3	2	1	0
Access	r/w	r/w	r/w	r/w	r/w	r/w	r/w	r/w

JITTER_FS (30/29h, 13 bits)

Sets the step value and the period of step of the switching frequency jitter. The default setting for the -0001 version is 0100000011110.

Bit	Item	Description
12:11	JITTER_STEP	Step value.
10:0	STEP_PERIOD	Step period.

Command	JITTER_FS															
Bit	15	14	13	12	11	10	9	8	7	6	5	4	3	2	1	0
Access	r	r	r	r/w	r/w	r/w	r/w	r/w	r/w	r/w	r/w	r/w	r/w	r/w	r/w	r/w

TON_MIN (2Bh, 5 bits)

Sets the minimum turn-on time. The default setting for the -0001 version is 01100.

Command	TON_MIN							
Bit	7	6	5	4	3	2	1	0
Access	r	r	r	r/w	r/w	r/w	r/w	r/w

MIN_OFF_TIME (2Ch, 5 bits)

Sets the minimum turn-off time. The default setting for the -0001 version is 01100.

Command	MIN_OFF_TIME							
Bit	7	6	5	4	3	2	1	0
Access	r	r	r	r/w	r/w	r/w	r/w	r/w

BURST_POINT_H (2E/2Dh, 13 bits)

Sets the PFC burst load at high line. The default setting for the -0001 version is 0000111101011.

Command	BURST_POINT_H															
Bit	15	14	13	12	11	10	9	8	7	6	5	4	3	2	1	0
Access	r	r	r	r/w	r/w	r/w	r/w	r/w	r/w	r/w	r/w	r/w	r/w	r/w	r/w	r/w

BURST_POINT_L (30/2Fh, 13bits)

Sets the PFC burst load at low line. The default setting for the -0001 version is 0000111101011.

Command	BURST_POINT_L															
Bit	15	14	13	12	11	10	9	8	7	6	5	4	3	2	1	0
Access	r	r	r	r/w	r/w	r/w	r/w	r/w	r/w	r/w	r/w	r/w	r/w	r/w	r/w	r/w

NORMAL_KI (31h, 8 bits)

Sets the Ki value at normal operation mode. The default setting for the -0001 version is 00010010.

Command	NORMAL_KI							
Bit	7	6	5	4	3	2	1	0
Access	r/w	r/w	r/w	r/w	r/w	r/w	r/w	r/w

NORMAL_KP (32h, 8 bits)

Sets the Kp value at normal operation mode. The default setting for the -0001 version is 01111000.

Command	NORMAL_KP							
Bit	7	6	5	4	3	2	1	0
Access	r/w	r/w	r/w	r/w	r/w	r/w	r/w	r/w

FAST_KI (34/33h, 10 bits)

Sets the Ki value at fast-loop operation mode. The default setting for the -0001 version is 0001001000.

Command	FAST_KI															
Bit	15	14	13	12	11	10	9	8	7	6	5	4	3	2	1	0
Access	r	r	r	r	r	r	r/w	r/w	r/w	r/w	r/w	r/w	r/w	r/w	r/w	r/w

FAST_KP (36/35h, 10 bits)

Sets the Kp value at fast-loop operation mode. The default setting for the -0001 version is 0100100000.

Command	FAST_KP															
Bit	15	14	13	12	11	10	9	8	7	6	5	4	3	2	1	0
Access	r	r	r	r	r	r	r/w	r/w	r/w	r/w	r/w	r/w	r/w	r/w	r/w	r/w

FASTLOOP_VOLTAGE (37h, 7 bits)

Sets the fast-loop level below the output voltage target. The default setting for the -0001 version is 0011111.

Command	FASTLOOP_VOLTAGE							
Bit	7	6	5	4	3	2	1	0
Access	r	r/w	r/w	r/w	r/w	r/w	r/w	r/w

VIN_BI_LEVEL (39/38h, 10 bits)

Sets the brown-in voltage of the input voltage. The default setting for the -0001 version is 0011101101.

Command	VIN_BI_LEVEL															
Bit	15	14	13	12	11	10	9	8	7	6	5	4	3	2	1	0
Access	r	r	r	r	r	r	r/w	r/w	r/w	r/w	r/w	r/w	r/w	r/w	r/w	r/w

VIN_BO_LEVEL (3B/3Ah, 10 bits)

Sets the brown-out voltage of the input voltage. The default setting for the -0001 version is 0011011001.

Command	VIN_BO_LEVEL															
Bit	15	14	13	12	11	10	9	8	7	6	5	4	3	2	1	0
Access	r	r	r	r	r	r	r/w	r/w	r/w	r/w	r/w	r/w	r/w	r/w	r/w	r/w

VIN_BIBO_TIME (3Ch, 8 bits)

Sets the brown-in and brown-out time of the input voltage. The default setting for the -0001 version is 00000101.

Bit	Item	Description
7:4	VIN_BI_TIME	Brown-in time.
3:0	VIN_BO_TIME	Brown-out time.

Command	VIN_BIBO_TIME							
Bit	7	6	5	4	3	2	1	0
Access	r/w	r/w	r/w	r/w	r/w	r/w	r/w	r/w

CSP_TD_REF_FILTER (3Dh, 8bits)

Enables the Iref_filter or Td_filter and set the bandwidth. The default setting for the -0001 version is 00111100.

Bit	Item	Description
7:6	-----	Reserved
5	IREF_FILTER	1: enable 0: disable
4	TD_FILTER	1: enable 0: disable
3:0	FC_SELECT	Cut-off frequency. 0000: 10.2kHz 0001: 5.1kHz 0010: 3.4kHz 0011: 2.5kHz 0100: 2.0kHz 0101: 1.7kHz 0110: 1.5kHz 0111: 1.3kHz 1000: 1.12kHz 1001: 1.02kHz 1010: 0.93kHz 1011: 0.85kHz 1100: 0.79kHz 1101: 0.73kHz 1110: 0.68kHz 1111: 0.64kHz

Command	CSP_TD_REF_FILTER							
Bit	7	6	5	4	3	2	1	0
Access	r/w	r/w	r/w	r/w	r/w	r/w	r/w	r/w

OCP_LIMIT (44h, 7 bits)

Sets the over-current limit of the inductor current. The default setting for the -0001 version is 0000100.

Command	OCP_LIMIT							
Bit	7	6	5	4	3	2	1	0
Access	r	r/w	r/w	r/w	r/w	r/w	r/w	r/w

OCP_MODE (45h, 4 bits)

Sets the over-current protection mode. The default setting for the -0001 version is 0000.

Bit	Item	Description
3	OCP_MODE_EN	1: enable 0: disable
2:0	OCP_MODE	000: latch 111: hiccup other: retry number

Command	OCP_MODE							
Bit	7	6	5	4	3	2	1	0
Access	r	r	r	r	r/w	r/w	r/w	r/w

OCP_RETRY_DELAY (47/46h, 10 bits)

Sets the delay time of the system recovery after the OCP event is cleared. The default setting for the -0001 version is 0111110100.

Command	OCP_RETRY_DELAY															
Bit	15	14	13	12	11	10	9	8	7	6	5	4	3	2	1	0
Access	r	r	r	r	r	r	r/w	r/w	r/w	r/w	r/w	r/w	r/w	r/w	r/w	r/w

OVP_LIMIT_H (48h, 7 bits)

Sets the over-voltage limit of the output voltage at high line. The default setting for the -0001 version is 1101101.

Command	OVP_LIMIT_H							
Bit	7	6	5	4	3	2	1	0
Access	r	r/w	r/w	r/w	r/w	r/w	r/w	r/w

OVP_LIMIT_L (49h, 7 bits)

Sets the over-voltage limit of the output voltage at low line. The default setting for the -0001 version is 1101101.

Command	OVP_LIMIT_L							
Bit	7	6	5	4	3	2	1	0
Access	r	r/w	r/w	r/w	r/w	r/w	r/w	r/w

CODE ID (4Ah, 8 bits)

Store customer code ID. The default setting for the -0001 version is 00000001.

Bit	Item	Description
7:2	CUSTOMER_ID	Customer number.
1:0	PROGRAMMED_CODE_ID	Programmed code number.

Command	CODE ID							
Bit	7	6	5	4	3	2	1	0
Access	r/w	r/w	r/w	r/w	r/w	r/w	r/w	r/w

IREF_COMP_VALUE1 (4Bh, 7 bits)

Sets the first compensation amplitude of the input current reference. The default setting for the -0001 version is 0000001.

Command	IREF_COMP_VALUE1							
Bit	7	6	5	4	3	2	1	0
Access	r	r/w	r/w	r/w	r/w	r/w	r/w	r/w

IREF_COMP_VALUE2 (4Ch, 7 bits)

Sets the second compensation amplitude of the input current reference. The default setting for the -0001 version is 0000011.

Command	IREF_COMP_VALUE2							
Bit	7	6	5	4	3	2	1	0
Access	r	r/w	r/w	r/w	r/w	r/w	r/w	r/w

IREF_COMP_VALUE3 (4Dh, 7 bits)

Sets the third compensation amplitude of the input current reference. The default setting for the -0001 version is 0001101.

Command	IREF_COMP_VALUE3							
Bit	7	6	5	4	3	2	1	0
Access	r	r/w	r/w	r/w	r/w	r/w	r/w	r/w

IREF_COMP_VALUE4 (4Eh, 7 bits)

Sets the fourth compensation amplitude of the input current reference. The default setting for the -0001 version is 0001100.

Command	IREF_COMP_VALUE4							
Bit	7	6	5	4	3	2	1	0
Access	r	r/w	r/w	r/w	r/w	r/w	r/w	r/w

VIN_LEVEL_SEL1 (4Fh, 8 bits)

Sets the voltage level one of the input voltage. The default setting for the -0001 version is 10011001.

Command	VIN_LEVEL_SEL1							
Bit	7	6	5	4	3	2	1	0
Access	r/w	r/w	r/w	r/w	r/w	r/w	r/w	r/w

VIN_LEVEL_SEL2 (50h, 8 bits)

Sets the voltage level two of the input voltage. The default setting for the -0001 version is 01001000.

Command	VIN_LEVEL_SEL2							
Bit	7	6	5	4	3	2	1	0
Access	r/w	r/w	r/w	r/w	r/w	r/w	r/w	r/w

VCOMP_MAX_L (52/51h, 16 bits)

Sets the maximum load. The default setting for the -0001 version is 0110110011010010.

Command	VCOMP_MAX_L															
Bit	15	14	13	12	11	10	9	8	7	6	5	4	3	2	1	0
Access	r/w	r/w	r/w	r/w	r/w	r/w	r/w	r/w	r/w	r/w	r/w	r/w	r/w	r/w	r/w	r/w

VCOMP_MAX_H (53h, 8 bits)

Sets the maximum load. The default setting for the -0001 version is 01011001.

Command	VCOMP_MAX_H							
Bit	7	6	5	4	3	2	1	0
Access	r/w	r/w	r/w	r/w	r/w	r/w	r/w	r/w

IREF_MAX (55/54h, 9 bits)

Set the maximum value of the input current reference. The default setting for the -0001 version is 111100100.

Command	IREF_MAX															
Bit	15	14	13	12	11	10	9	8	7	6	5	4	3	2	1	0
Access	r	r	r	r	r	r	r	r/w	r/w	r/w	r/w	r/w	r/w	r/w	r/w	r/w

SYS_CONFIG (56h, 8 bits)

Configure the system. The default setting for the -0001 version is 00110100.

Bit	Item	Description
7	BURST_LLC_SYNC_EN	Synchronize PFC with LLC in burst mode. 1: enable 0: disable
6	-----	Reserved.
5	POWER_ON	Power on the system. 1: enable 0: disable
4	LLC_EN	Enable LLC part. 1: enable 0: disable
3	AUTO_VOUT_EN	Output voltage target is determined by the load. 1: enable 0: disable
2	IREF_COMP_EN	Compensate the current of the input capacitance. 1: enable 0: disable
1	JITTER_EN	Switching frequency jitter. 1: enable 0: disable
0	ZCD_EN	Valley turn on. 1: enable 0: disable

Command	SYS_CONFIG							
Bit	7	6	5	4	3	2	1	0
Access	r/w	r/w	r/w	r/w	r/w	r/w	r/w	r/w

AD_SLEEP_FS (58/57h, 10 bits)

Set the ADC sample rate when PWM is off. The default setting for the -0001 version is 1100100000.

Command	AD_SLEEP_FS															
Bit	15	14	13	12	11	10	9	8	7	6	5	4	3	2	1	0
Access	r	r	r	r	r	r	r/w	r/w	r/w	r/w	r/w	r/w	r/w	r/w	r/w	r/w

TON_AHEAD (59h, 4 bits)

Sets the peak-current sample point. The default setting for the -0001 version is 0010.

Command	TON_AHEAD							
Bit	7	6	5	4	3	2	1	0
Access	r	r	r	r	r/w	r/w	r/w	r/w

OLP_HIGH (5Ah, 7 bits)

Sets the open-loop protection at high level. The default setting for the -0001 version is 1011100.

Command	OLP_HIGH							
Bit	7	6	5	4	3	2	1	0
Access	r	r/w	r/w	r/w	r/w	r/w	r/w	r/w

OLP_LOW (5Bh, 7 bits)

Sets the open-loop protection at low level. The default setting for the -0001 version is 0111101.

Command	OLP_LOW							
Bit	7	6	5	4	3	2	1	0
Access	r	r/w	r/w	r/w	r/w	r/w	r/w	r/w

SOFT_TON (5Ch, 7 bits)

Sets the soft turn-on time when the system recovers from OVP. The default setting for the -0001 version is 0101000.

Command	SOFT_TON							
Bit	7	6	5	4	3	2	1	0
Access	r	r/w	r/w	r/w	r/w	r/w	r/w	r/w

SOFT_SWITCH_CNT (5Dh, 4 bits)

Sets the number of switching events during soft turn-on. The default setting for the -0001 version is 0111.

Command	SOFT_SWITCH_CNT							
Bit	7	6	5	4	3	2	1	0
Access	r	r	r	r	r/w	r/w	r/w	r/w

MFR_MERGE_REG (5Eh, 8 bits)

The default setting for the -0001 version is 00100001.

Bit	Item	Description
7:3	SWITCH_BLANK_TIME1	PWM off blanking time.
2:1	CURRENT_MIRROR_GAIN	Sets the current mirror gain. The reference current is 62.5µA. 00: GAIN = 1 01: GAIN = 1.4 10: GAIN = 1.6 11: GAIN = 2
0	I2C_FILTER_EN	I ² C filter. 1: enable 0: disable

Command	MFR_MERGE_REG							
Bit	7	6	5	4	3	2	1	0
Access	r/w	r/w	r/w	r/w	r/w	r/w	r/w	r/w

SWITCH_BLANK_TIME (5Fh, 8 bits)

Sets the PWM on blanking time. The default setting for the -0001 version is 00110101.

Bit	Item	Description
7:4	SWITCH_BLANK_TIME2	PWM off blanking time for OCP.
3:0	SWITCH_BLANK_TIME3	PWM off blanking time for OCL.

Command	SWITCH_BLANK_TIME							
Bit	7	6	5	4	3	2	1	0
Access	r/w	r/w	r/w	r/w	r/w	r/w	r/w	r/w

OVP_DELAYTIME (60h, 6 bits)

Sets the blanking time of OVP. The default setting for the -0001 version is 110010.

Command	OVP_DELAYTIME							
Bit	7	6	5	4	3	2	1	0
Access	r	r	r/w	r/w	r/w	r/w	r/w	r/w

BURST_MODE_HYS (61h, 6 bits)

Sets the hysteresis of the output voltage in burst mode. The default setting for the -0001 version is 001010.

Command	BURST_MODE_HYS							
Bit	7	6	5	4	3	2	1	0
Access	r	r	r/w	r/w	r/w	r/w	r/w	r/w

ERROR_ZERO_REGION (62h, 5 bits)

Sets the non-regulation region of the output voltage. The default setting for the -0001 version is 00000.

Command	ERROR_ZERO_REGION							
Bit	7	6	5	4	3	2	1	0
Access	r	r	r	r/w	r/w	r/w	r/w	r/w

VIN_ZERO_POINT (63h, 7 bits)

Sets the period detection point of the input voltage. The default setting for the -0001 version is 1010010.

Command	VIN_ZERO_POINT							
Bit	7	6	5	4	3	2	1	0
Access	r	r/w	r/w	r/w	r/w	r/w	r/w	r/w

VIN_PEAK_VALUE (64h, 7 bits)

Sets the value to detect the top of the input voltage. The default setting for the -0001 version is 0010100.

Command	VIN_PEAK_VALUE							
Bit	7	6	5	4	3	2	1	0
Access	r	r/w	r/w	r/w	r/w	r/w	r/w	r/w

VIN_VALLEY_VALUE (65h, 7 bits)

Sets the value to detect the valley of the input voltage. The default setting for the -0001 version is 0111101.

Command	VIN_VALLEY_VALUE							
Bit	7	6	5	4	3	2	1	0
Access	r	r/w	r/w	r/w	r/w	r/w	r/w	r/w

IPK_BIAS_TRIM (66h, 8 bits)

Trims the bias voltage at CSP. The default setting for the -0001 version is 00000000.

Bit	Item	Description
7	CSP_FAULT_MODE	Determine the control mode when CSP is open or shorted. 1: hiccup 0: latch
6	IPK_BIAS_SAMPLE_EN	Enable sampling of the CSP bias voltage when power is on. 1: enable 0: disable
5:0	IPK_BIAS_TRIM	Trim the bias voltage at CSP.

Command	IPK_BIAS_TRIM							
Bit	7	6	5	4	3	2	1	0
Access	r/w	r/w	r/w	r/w	r/w	r/w	r/w	r/w

ADC_OFFSET_TRIM (67h, 5 bits)

Trims the ADC offset. The default setting for the -0001 version is 00000.

Command	ADC_OFFSET_TRIM							
Bit	7	6	5	4	3	2	1	0
Access	r	r	r	r/w	r/w	r/w	r/w	r/w

DELTA_VOLTAGE (68h, 7 bits)

Sets the minimum delta voltage between the input voltage and output voltage for CSP bias voltage sampling. The default setting for the -0001 version is 0101001.

Command	DELTA_VOLTAGE							
Bit	7	6	5	4	3	2	1	0
Access	r	r/w	r/w	r/w	r/w	r/w	r/w	r/w

VIN_LEVEL1 (69h, 7 bits)

Input voltage level one for the CSP bias voltage sample. The default setting for the -0001 version is 0010100.

Command	VIN_LEVEL1							
Bit	7	6	5	4	3	2	1	0
Access	r	r/w	r/w	r/w	r/w	r/w	r/w	r/w

VIN_LEVEL2 (6Ah, 7 bits)

Input voltage level two for the CSP bias voltage sample. The default setting for the -0001 version is 0101001.

Command	VIN_LEVEL2							
Bit	7	6	5	4	3	2	1	0
Access	r	r/w	r/w	r/w	r/w	r/w	r/w	r/w

VIN_LEVEL3 (6Bh, 7 bits)

Input voltage level three for the CSP bias voltage sample. The default setting for the -0001 version is 0111101.

Command	VIN_LEVEL3							
Bit	7	6	5	4	3	2	1	0
Access	r	r/w	r/w	r/w	r/w	r/w	r/w	r/w

VIN_LEVEL4 (6D/6Ch, 10 bits)

Input voltage level four for the CSP bias voltage sample. The default setting for the -0001 version is 0100110011.

Command	VIN_LEVEL4															
Bit	15	14	13	12	11	10	9	8	7	6	5	4	3	2	1	0
Access	r	r	r	r	r	r	r/w	r/w	r/w	r/w	r/w	r/w	r/w	r/w	r/w	r/w

VIN_HL_HYS (6Eh, 8 bits)

Sets the hysteresis of the input voltage for adaptive control. The default setting for the -0001 version is 00000101.

Command	VIN_HL_HYS							
Bit	7	6	5	4	3	2	1	0
Access	r/w	r/w	r/w	r/w	r/w	r/w	r/w	r/w

ZCD_VIN_HYS (6Fh, 6 bits)

Sets the hysteresis of the input voltage for valley turn on. The default setting for the -0001 version is 010100.

Command	ZCD_VIN_HYS							
Bit	7	6	5	4	3	2	1	0
Access	r	r	r/w	r/w	r/w	r/w	r/w	r/w

NOTICE: The information in this document is subject to change without notice. Users should warrant and guarantee that third party Intellectual Property rights are not infringed upon when integrating MPS products into any application. MPS will not assume any legal responsibility for any said applications.