

Radiation Hardened Fast Sample and Hold

HS-2420EH

The HS-2420EH is a radiation hardened monolithic circuit consisting of a high performance operational amplifier with its output in series with an ultra-low leakage analog switch and a MOSFET input unity gain amplifier.

With an external hold capacitor connected to the switch output, a versatile high performance sample-and-hold or track-and-hold circuit is formed. When the switch is closed, the device behaves as an operational amplifier and any of the standard op amp feedback networks may be connected around the device to control gain, frequency response, etc. When the switch is opened, the output will remain at its last level.

Performance as a sample-and-hold compares very favorably with other monolithic, hybrid, modular and discrete circuits. Accuracy to better than 0.01% is achievable over the temperature range. Fast acquisition is coupled with superior droop characteristics, even at high temperatures. High slew rate, wide bandwidth and low acquisition time produce excellent dynamic characteristics. The ability to operate at gains greater than 1 frequently eliminates the need for external scaling amplifiers.

The device may also be used as a versatile operational amplifier with a gated output for applications such as analog switches, peak holding circuits, etc.

Specifications for Rad Hard QML devices are controlled by the Defense Logistics Agency Land and Maritime (DLA). The SMD numbers listed here must be used when ordering.

Detailed Electrical Specifications for these devices are contained in SMD [5962-95669](#).

Features

- Electrically screened to SMD #[5962-95669](#)
- QML qualified per MIL-PRF-38535 requirements
- Maximum acquisition time
 - 10V Step to 0.1% 4μs
 - 10V Step to 0.01% 6μs
- Maximum drift current 10nA (maximum over-temperature)
- TTL compatible control input
- Power supply rejection ≥ 80dB
- Radiation tolerance
 - High dose rate (50 to 300rad(Si)/s) 100krad(Si)
 - Low dose rate (0.01rad(Si)/s) 100krad(Si)*

* Only the EH device is wafer-by-wafer acceptance tested at the low dose rate and guaranteed to 50krad(Si). The 100krad(Si) limit is established by characterization only.

- No latch-up

Applications

- Data acquisition systems
- D to A deglitcher
- Auto zero systems
- Peak detector
- Gated op amp

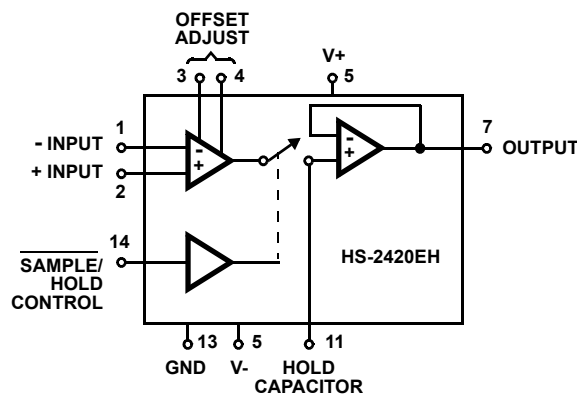
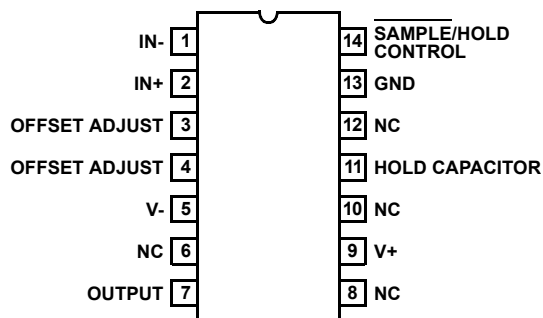

FIGURE 1. FUNCTIONAL DIAGRAM

HS-2420EH

HS-2420EH
14 LD METAL-SEALED SIDE-BRAZED CERAMIC DIP
MIL-STD-1835, CDIP2-T14
TOP VIEW



Pin Descriptions

PIN #	PIN NAME	DESCRIPTION
1	IN-	Inverting input to the operational amplifier
2	IN+	Non-inverting input to the operational amplifier
3, 4	OFFSET ADJUST	Connect a 100kΩ potentiometer across these pins to null out the offset voltage.
5	V-	Negative power supply
6, 8, 10, 12	NC	No connect pin.
7	OUTPUT	Output of the unity gain amplifier
9	V+	Positive Power Supply
11	HOLD CAPACITOR	Connect the hold capacitor between this pin and GND.
13	GND	Ground connection of the device
14	SAMPLE/HOLD CONTROL	Control input to the series analog switch.

Ordering Information

ORDERING SMD NUMBER (Note 1)	PART NUMBER (Note 2)	TEMPERATURE RANGE (°C)	PACKAGE (RoHS Compliant)	PKG. DWG. #
5962R9566902VCC	HS1B-2420EH-Q	-55 to +125	14 Ld SBDIP	D14.3
HS1B-2420EH/PROTO	HS1B-2420EH/PROTO	-55 to +125	14 Ld SBDIP	D14.3

NOTES:

1. These Intersil Pb-free Hermetic packaged products employ 100% Au plate - e4 termination finish, which is RoHS compliant and compatible with both SnPb and Pb-free soldering operations.
2. Specifications for Rad Hard QML devices are controlled by the Defense Logistics Agency Land and Maritime (DLA). The SMD numbers listed in the "Ordering Information" table must be used when ordering.

Test Circuits

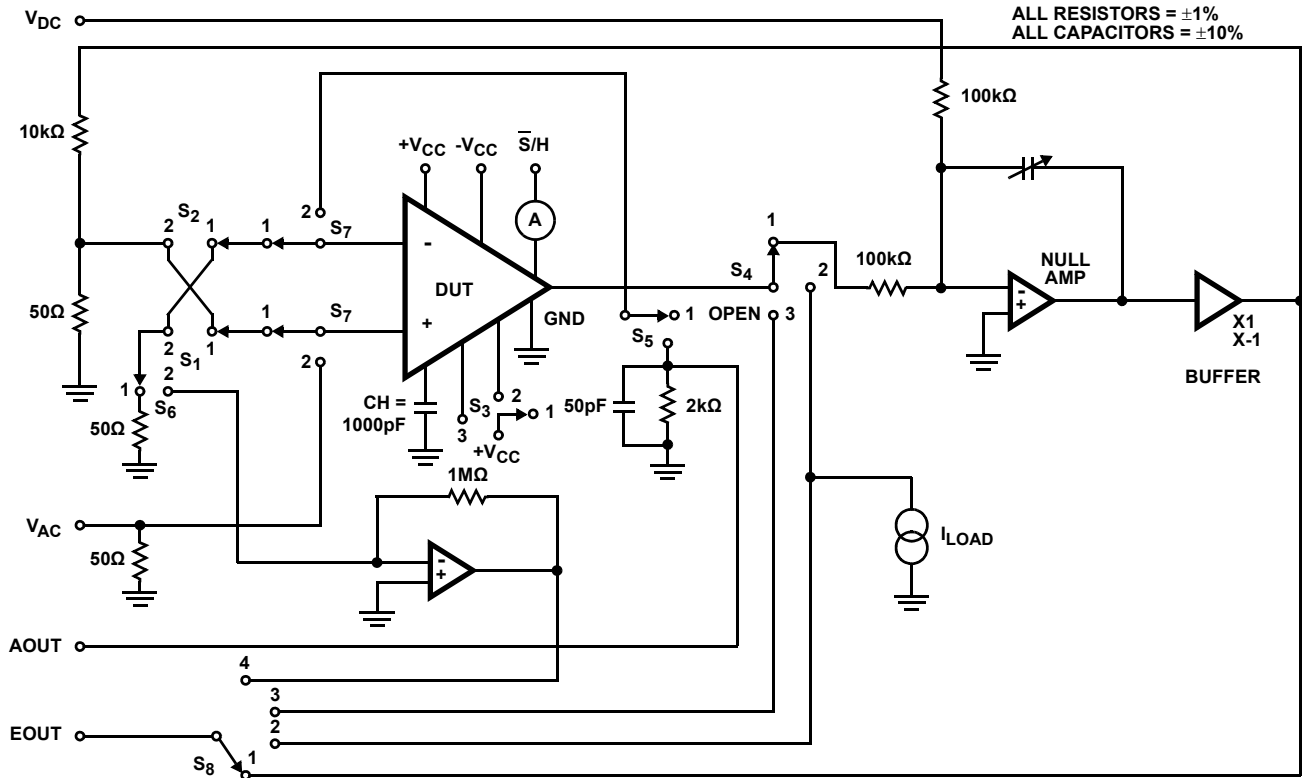
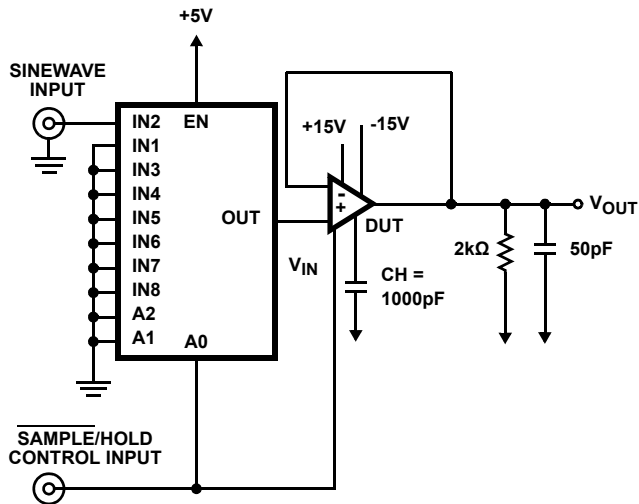

FIGURE 2. TEST FIXTURE SCHEMATIC (SWITCH POSITIONS S₁ - S₈ DETERMINE CONFIGURATION)



NOTE: Compute Hold mode feedthrough attenuation from the formula:

$$\text{Feedthrough Attenuation} = 20 \log \left(\frac{V_{\text{OUT HOLD}}}{V_{\text{IN HOLD}}} \right)$$

Where V_{OUT HOLD} = peak-to-peak value of output Sinewave during the Hold mode.

FIGURE 3. HOLD MODE FEEDTHROUGH ATTENUATION

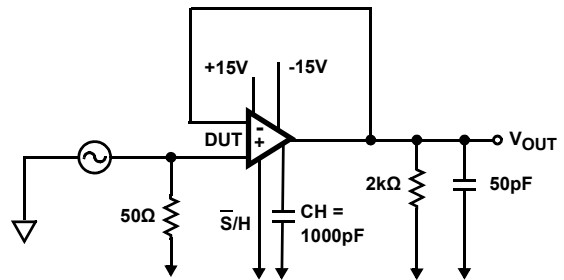

NOTE: GBWP is the frequency of V_{INPUT} at which:

$$20 \log \left(\frac{V_{\text{OUT}}}{V_{\text{INPUT}}} \right) = -3\text{dB}$$

FIGURE 4. GAIN BANDWIDTH PRODUCT

Test Circuits (Continued)

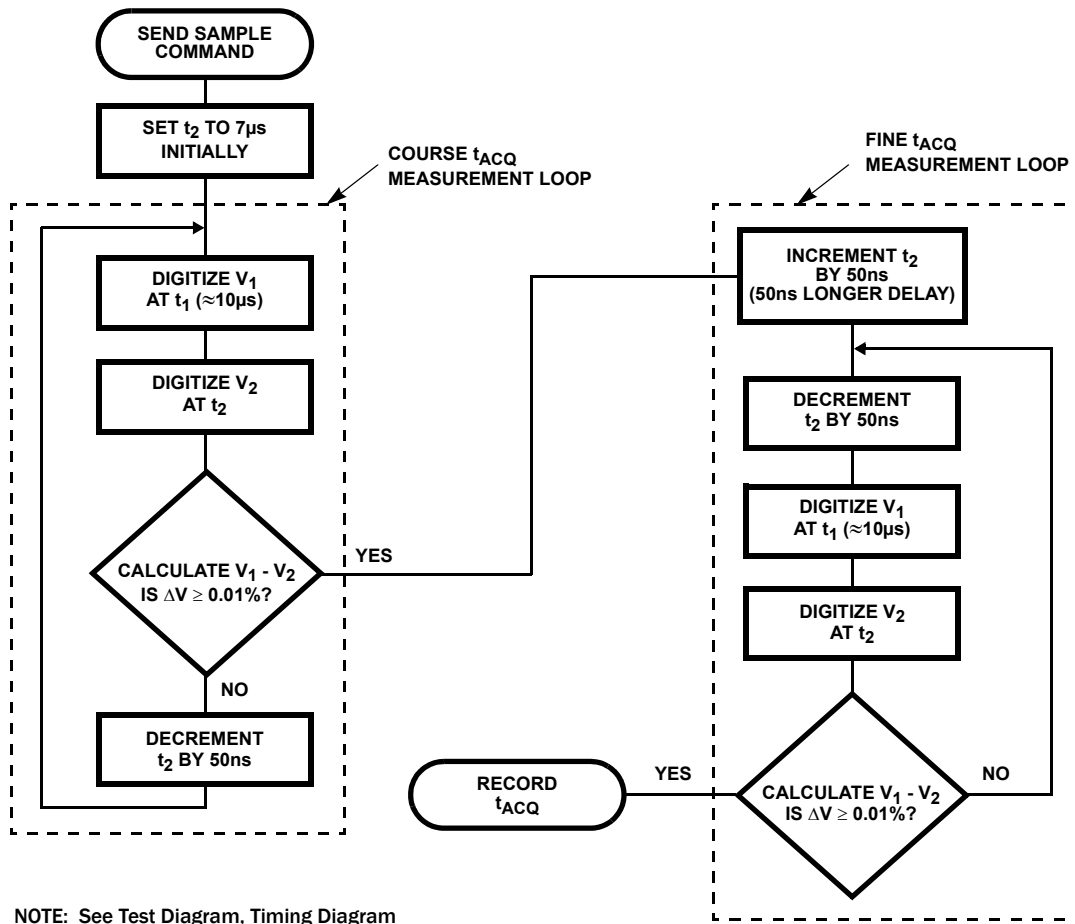

NOTE: See Test Diagram, Timing Diagram

FIGURE 5. ACQUISITION TIME (t_{ACQ} TO 0.01% IS SHOWN, t_{ACQ} TO 0.1% IS DONE IN THE SAME MANNER)

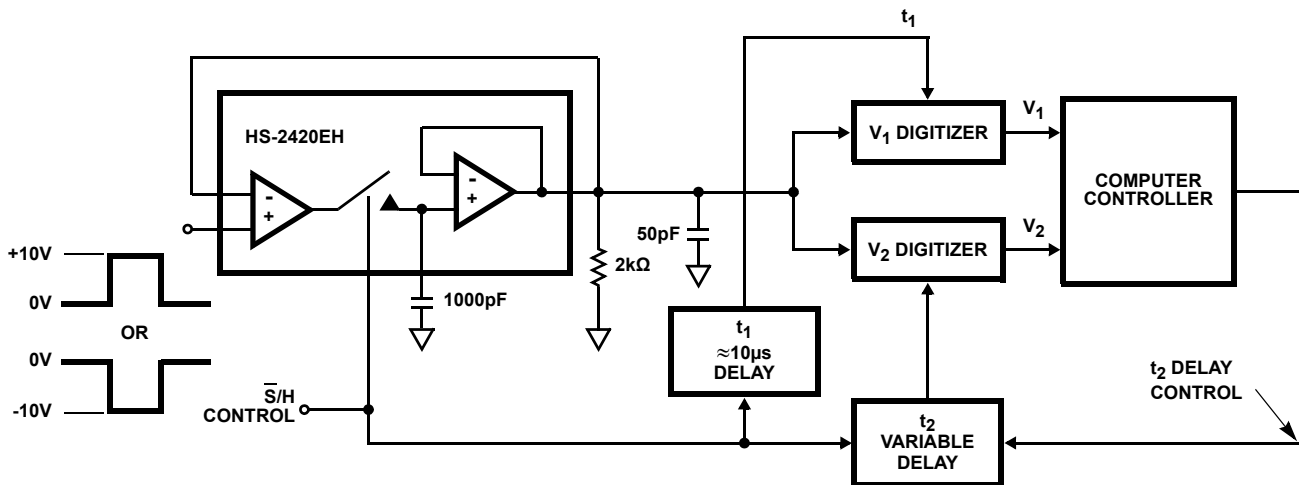

FIGURE 6. BLOCK DIAGRAM FOR ACQUISITION TIME MEASUREMENT

Timing Waveforms

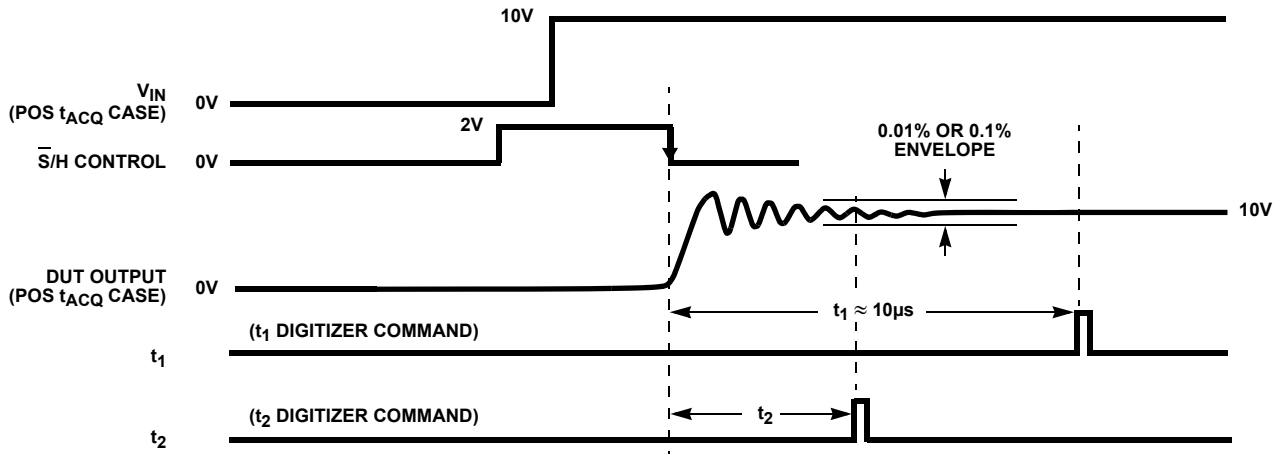

FIGURE 7. TIMING DIAGRAM FOR ACQUISITION TIME, (POSITIVE t_{ACQ} CASE)

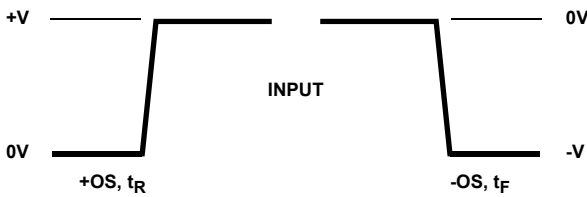

FIGURE 8A.

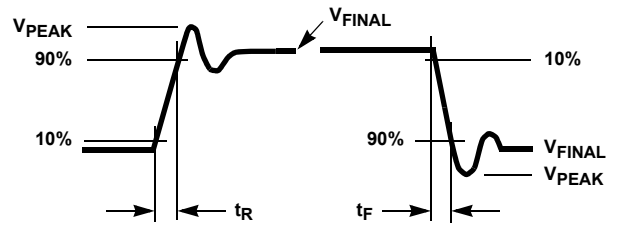

FIGURE 8B.

FIGURE 8. OVERSHOOT, RISE AND FALL TIME WAVEFORMS

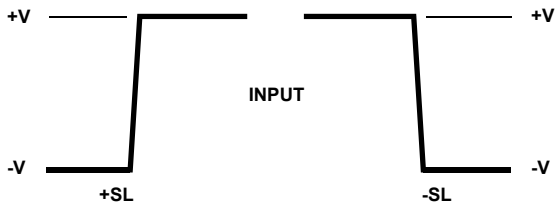

FIGURE 9A.

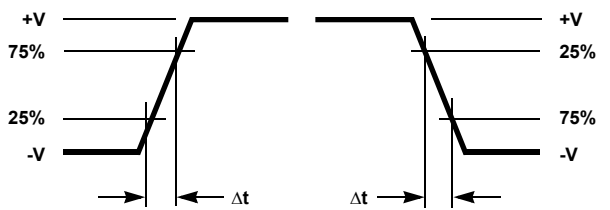

FIGURE 9B.

FIGURE 9. SLEW RATE WAVEFORMS

Typical Performance Curves $V_{SUPPLY} = \pm 15V_{DC}$, $T_A = +25^\circ C$, $CH = 1000pF$, Unless Otherwise Specified

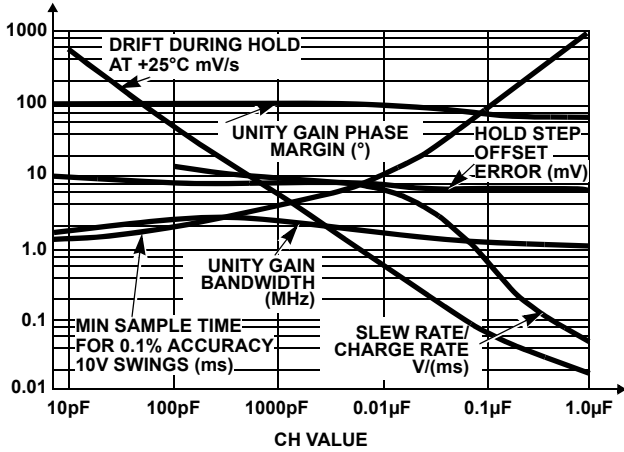

FIGURE 10. TYPICAL SAMPLE AND HOLD PERFORMANCE vs HOLDING CAPACITOR

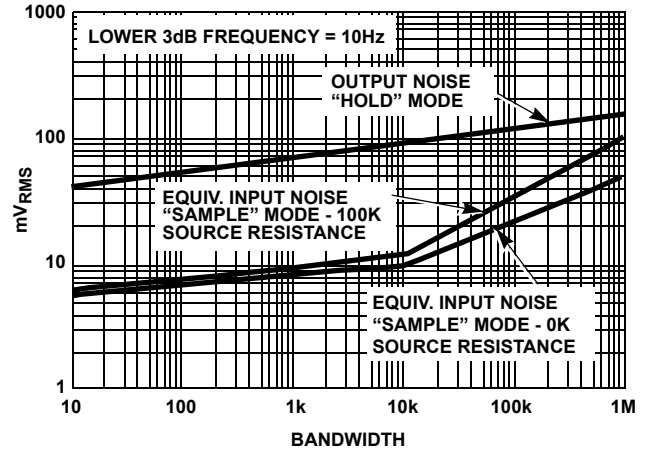

FIGURE 11. BROADBAND NOISE CHARACTERISTICS

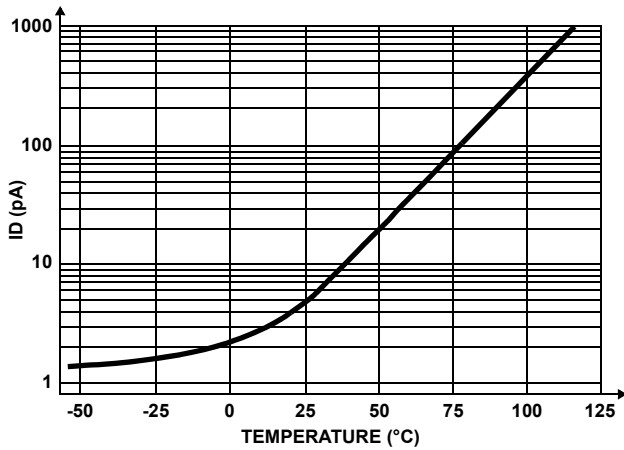

FIGURE 12. DRIFT CURRENT vs TEMPERATURE

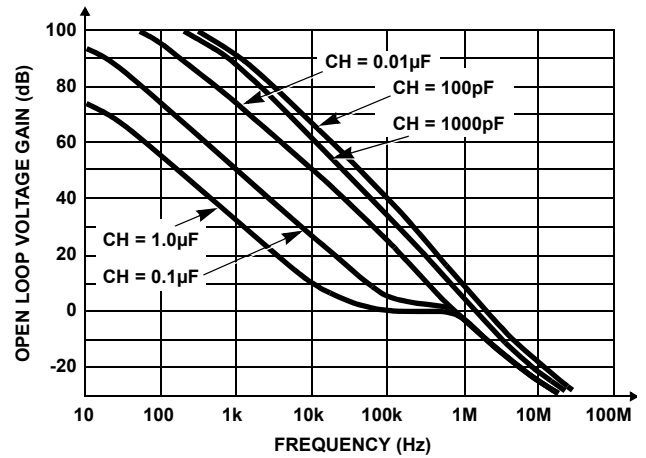

FIGURE 13. OPEN LOOP FREQUENCY RESPONSE

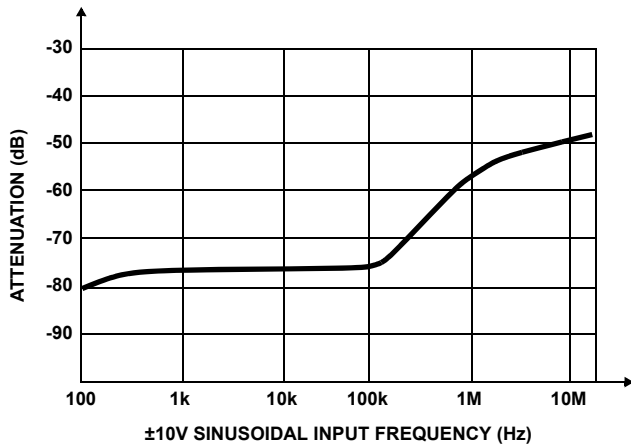

FIGURE 14. HOLD MODE FEEDTHROUGH ATTENUATION
CH = 1000pF

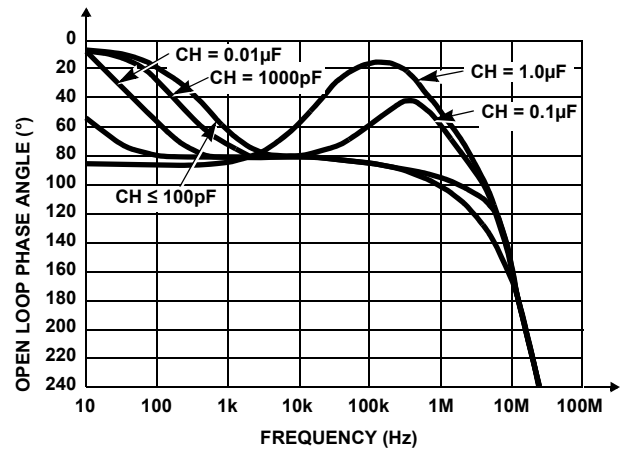
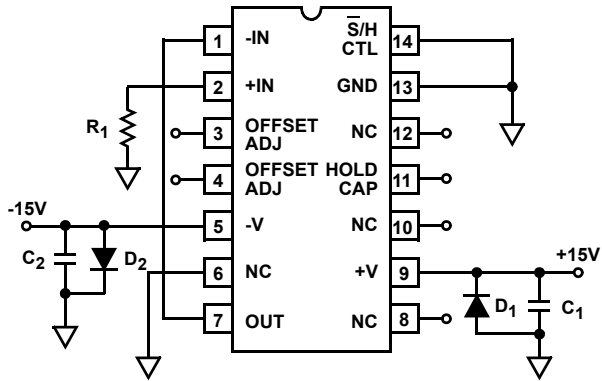

FIGURE 15. OPEN LOOP PHASE RESPONSE

Burn-in Circuit

HS-2420EH CERDIP



NOTES:

- $R_1 = 100k\Omega \pm 5\%$ (per socket)
- $C_1 = C_2 = 0.1\mu F$ (one per row) or $0.01\mu F$ (one per socket)
- $D_1 = D_2 = 1N4002$ or equivalent (per board)

Irradiation Circuit

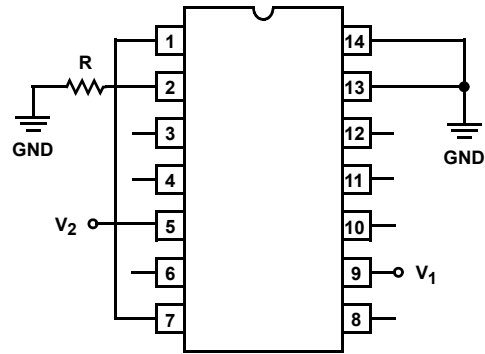

NOTES:

- $V_1 = +15V$
- $V_2 = -15V$
- $R = 100k\Omega$

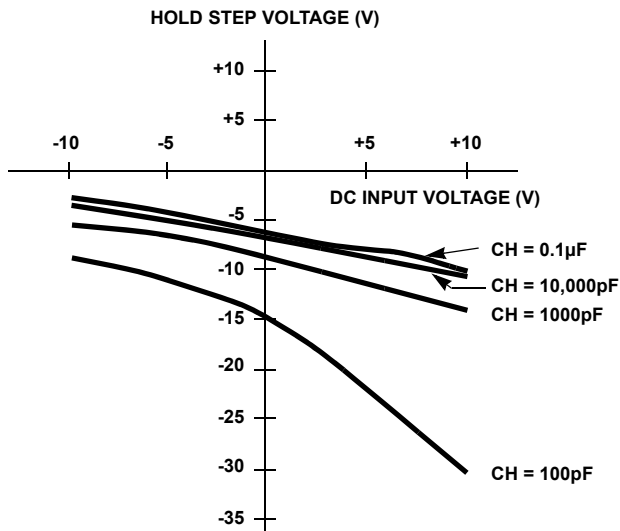

FIGURE 16. HOLD STEP vs INPUT VOLTAGE

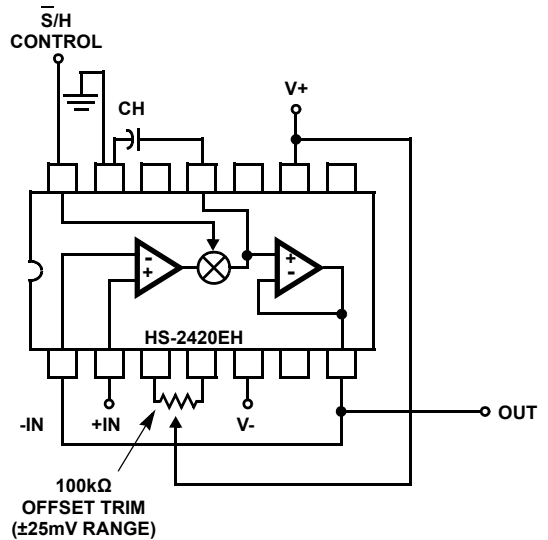

FIGURE 17. BASIC SAMPLE-AND-HOLD with OFFSET TRIM

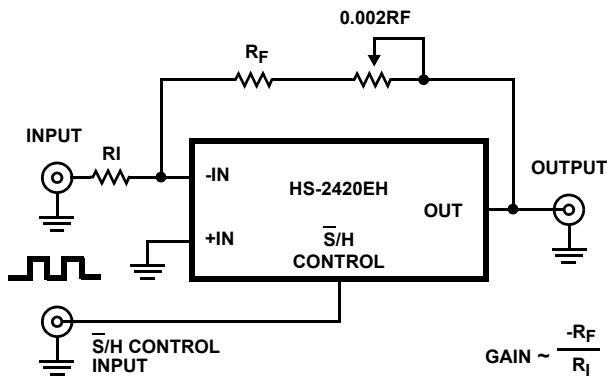

FIGURE 18. INVERTING CONFIGURATION with GAIN ADJUST

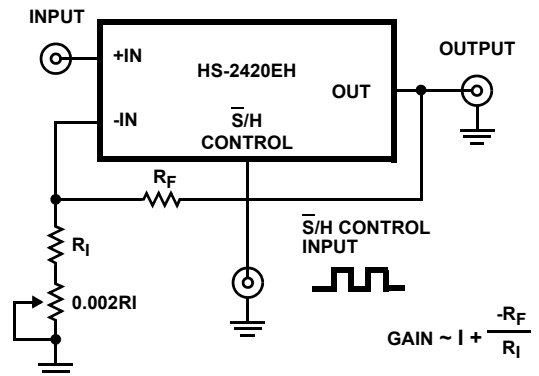

FIGURE 19. NONINVERTING CONFIGURATION WITH GAIN ADJUST

Offset and Gain Adjustment

Offset Adjustment

The offset voltage of the HS-2420EH may be adjusted using a 100kΩ trim pot, as shown in [Figure 17](#). The recommended adjustment procedure is:

1. Apply 0V to the sample-and-hold input, and a square wave to the S/H control.
2. Adjust the trim pot for 0V output in the hold mode.

Gain Adjustment

The linear variation in pedestal voltage with sample-and-hold input voltage causes a -0.06% gain error (CH = 1000pF). In some applications (D/A deglitcher, A/D converter) the gain error can be adjusted elsewhere in the system, while in other applications it must be adjusted at the sample-and-hold. [Figures 18](#) and [19](#) illustrate how to implement gain error adjust on the sample-and-hold.

The recommended procedure for adjusting gain error is:

1. Perform offset adjustment.
2. Apply the nominal input voltage that should produce a +10V output.
3. Adjust the trim pot for +10V output in the hold mode.
4. Apply the nominal input voltage that should produce a -10V output.

Measure the output hold voltage (V-10 NOMINAL). Adjust the trim pot for an output hold voltage of:

$$\frac{(V-10 \text{ NOMINAL}) + (-10V)}{2}$$

HS-2420EH

Die Characteristics

DIE DIMENSIONS:

97mils x 61mils x 19mils

METALLIZATION:

Type: Al

Thickness: $16\text{k}\text{\AA} \pm 2\text{k}\text{\AA}$

GLASSIVATION:

Type: Silox

Thickness: $14\text{k}\text{\AA} \pm 2\text{k}\text{\AA}$

WORST CASE CURRENT DENSITY:

$2.0 \times 10^5 \text{A/cm}^2$

TRANSISTOR COUNT:

78

PROCESS:

Bipolar-Di

Metallization Mask Layout

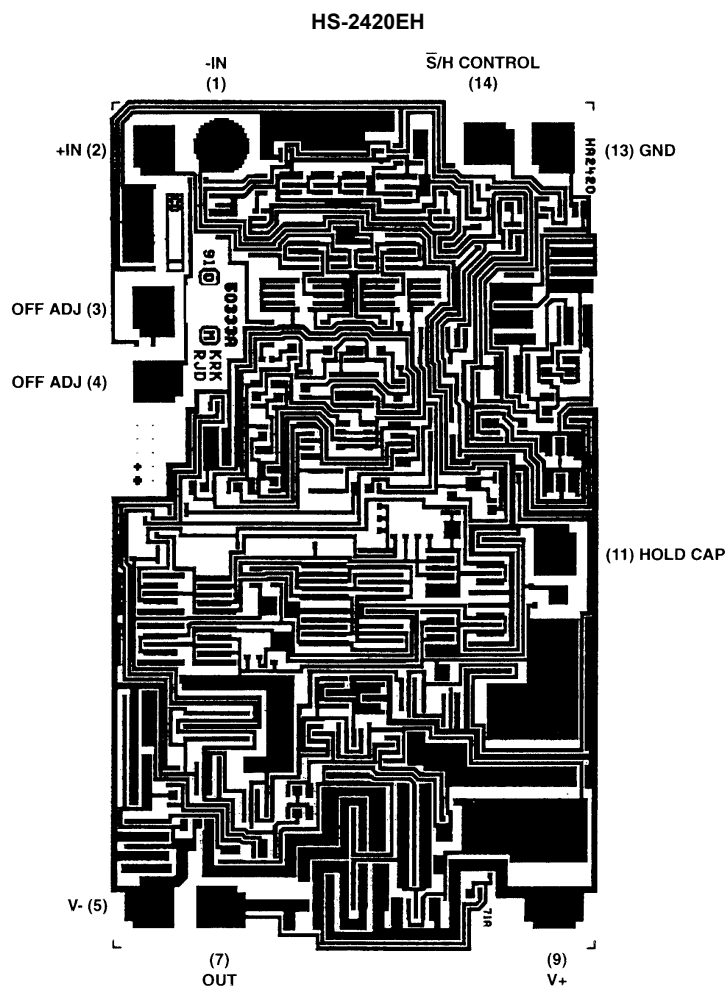

Revision History

The revision history provided is for informational purposes only and is believed to be accurate, but not warranted. Please go to the web to make sure that you have the latest revision.

DATE	REVISION	CHANGE
March 17, 2015	FN8727.0	Initial Release

About Intersil

Intersil Corporation is a leading provider of innovative power management and precision analog solutions. The company's products address some of the largest markets within the industrial and infrastructure, mobile computing and high-end consumer markets.

For the most updated datasheet, application notes, related documentation and related parts, please see the respective product information page found at www.intersil.com.

You may report errors or suggestions for improving this datasheet by visiting www.intersil.com/ask.

Reliability reports are also available from our website at www.intersil.com/support

For additional products, see www.intersil.com/en/products.html

Intersil products are manufactured, assembled and tested utilizing ISO9001 quality systems as noted in the quality certifications found at www.intersil.com/en/support/qualandreliability.html

Intersil products are sold by description only. Intersil Corporation reserves the right to make changes in circuit design, software and/or specifications at any time without notice. Accordingly, the reader is cautioned to verify that data sheets are current before placing orders. Information furnished by Intersil is believed to be accurate and reliable. However, no responsibility is assumed by Intersil or its subsidiaries for its use; nor for any infringements of patents or other rights of third parties which may result from its use. No license is granted by implication or otherwise under any patent or patent rights of Intersil or its subsidiaries.

For information regarding Intersil Corporation and its products, see www.intersil.com

HS-2420EH

Ceramic Dual-In-Line Metal Seal Packages (SBDIP)

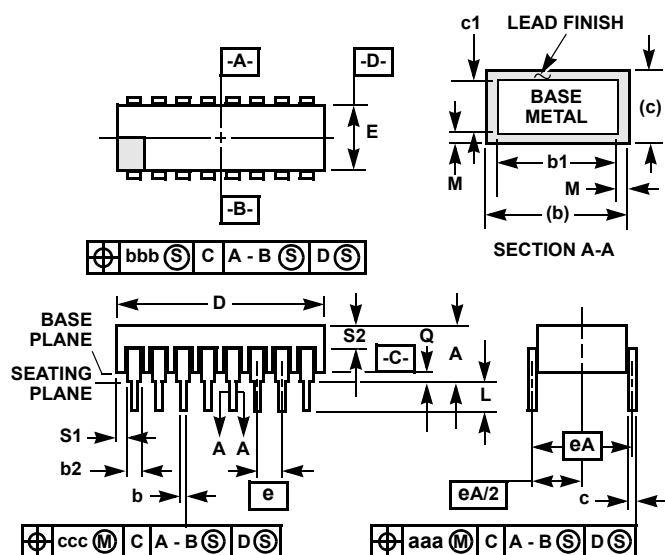

D14.3 MIL-STD-1835 CDIP2-T14 (D-1, CONFIGURATION C) 14 LEAD CERAMIC DUAL-IN-LINE METAL SEAL PACKAGE

SYMBOL	INCHES		MILLIMETERS		NOTES
	MIN	MAX	MIN	MAX	
A	-	0.200	-	5.08	-
b	0.014	0.026	0.36	0.66	2
b1	0.014	0.023	0.36	0.58	3
b2	0.045	0.065	1.14	1.65	-
b3	0.023	0.045	0.58	1.14	4
c	0.008	0.018	0.20	0.46	2
c1	0.008	0.015	0.20	0.38	3
D	-	0.785	-	19.94	-
E	0.220	0.310	5.59	7.87	-
e	0.100 BSC		2.54 BSC		-
eA	0.300 BSC		7.62 BSC		-
eA/2	0.150 BSC		3.81 BSC		-
L	0.125	0.200	3.18	5.08	-
Q	0.015	0.060	0.38	1.52	5
S1	0.005	-	0.13	-	6
S2	0.005	-	0.13	-	7
α	90°	105°	90°	105°	-
aaa	-	0.015	-	0.38	-
bbb	-	0.030	-	0.76	-
ccc	-	0.010	-	0.25	-
M	-	0.0015	-	0.038	2
N	14		14		8

NOTES:

- Index area: A notch or a pin one identification mark shall be located adjacent to pin one and shall be located within the shaded area shown. The manufacturer's identification shall not be used as a pin one identification mark.
- The maximum limits of lead dimensions b and c or M shall be measured at the centroid of the finished lead surfaces, when solder dip or tin plate lead finish is applied.
- Dimensions b1 and c1 apply to lead base metal only. Dimension M applies to lead plating and finish thickness.
- Corner leads (1, N, N/2, and N/2+1) may be configured with a partial lead paddle. For this configuration dimension b3 replaces dimension b2.
- Dimension Q shall be measured from the seating plane to the base plane.
- Measure dimension S1 at all four corners.
- Measure dimension S2 from the top of the ceramic body to the nearest metallization or lead.
- N is the maximum number of terminal positions.
- Braze fillets shall be concave.
- Dimensioning and tolerancing per ANSI Y14.5M - 1982.
- Controlling dimension: INCH.

Rev. 0 4/94