

# SPECIFICATION FOR APPROVAL

## 产品承认书

CUSTOMER: \_\_\_\_\_  
CUSTOMER NO. : \_\_\_\_\_  
HSW PART NO. : **HS2048G**  
DESCRIPTION: 10/100/1000 BASE-T DUAL PORT SMD MODULE

**ATTACHMENT:**

■ SPECIFICATION

■ SAMPLE Q'TY OF SAMPLES **3** PCS

**CUSTOMER APPROVAL**  
(客户承认章)

**HSW APPROVAL**  
(公司承认章)

SALES BY:

SALES BY:

张静

QA DEPT. :

CHECKED BY:

刘君

ENG. DEPT.:

APPROVAL BY:

贺江

**深圳市华升微电子有限公司**

TEL:86-755- 33272179/33270812

FAX:86-755-61174076

[www.h1102.com](http://www.h1102.com)

[sales@h1102.com](mailto:sales@h1102.com)

[hswdz01@163.com](mailto:hswdz01@163.com)

PLEASE REPLY THIS SHEET TO US AFTER SIGNATURE(请签字后回传本页)

## A. ELECTRICAL SPECIFICATIONS @25°C

Inductance OCL:	350uH Min @ 100KHz	0.2V 8mA DC BIAS
Leakage Inductance:	0.50uH Max @ 100KHz	0.2V
Interwinding Capacitance:	25PF TYP @ 100KHz	0.2V
Turn Ratio:	1CT:1CT±5%	
Polarity:	2-47,5-44,8-41,11-38,14-35,17-32,20-29,23-26	In-Phase
Insertion Loss:	1-100 MHz	-1.4dB Max
Return Loss	0.5-30 MHz	-18dB Min
	40.0MHz	- 14.4 dB Min
	60-80MHz	- 12.0dB Min
Cross Talk:	0.30-60MHz	- 40dB Min
	60-100MHz	- 35dB Min
Common Mode Rejection:	0.1-100MHz	- 40dB Min
Isolation HI-POT:	1500VAC,1mA,1s	
Product Type:	Green Product	
Operating Temperature:	0°C TO 70°C	

## B. SCHEMATIC:

### HS2048G

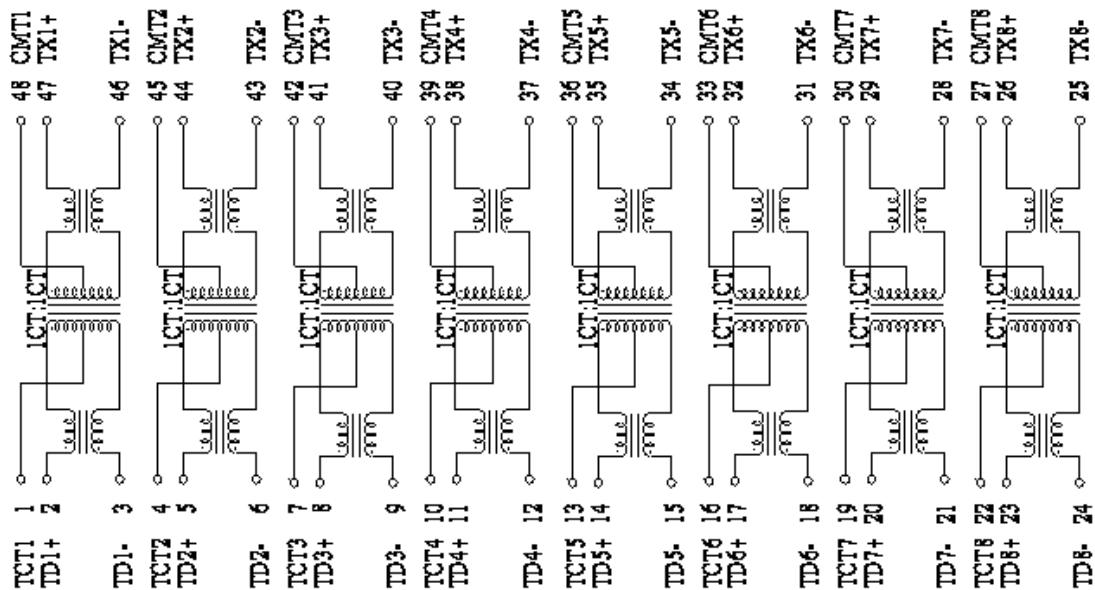



C. DIMENSIONS & MARKING:

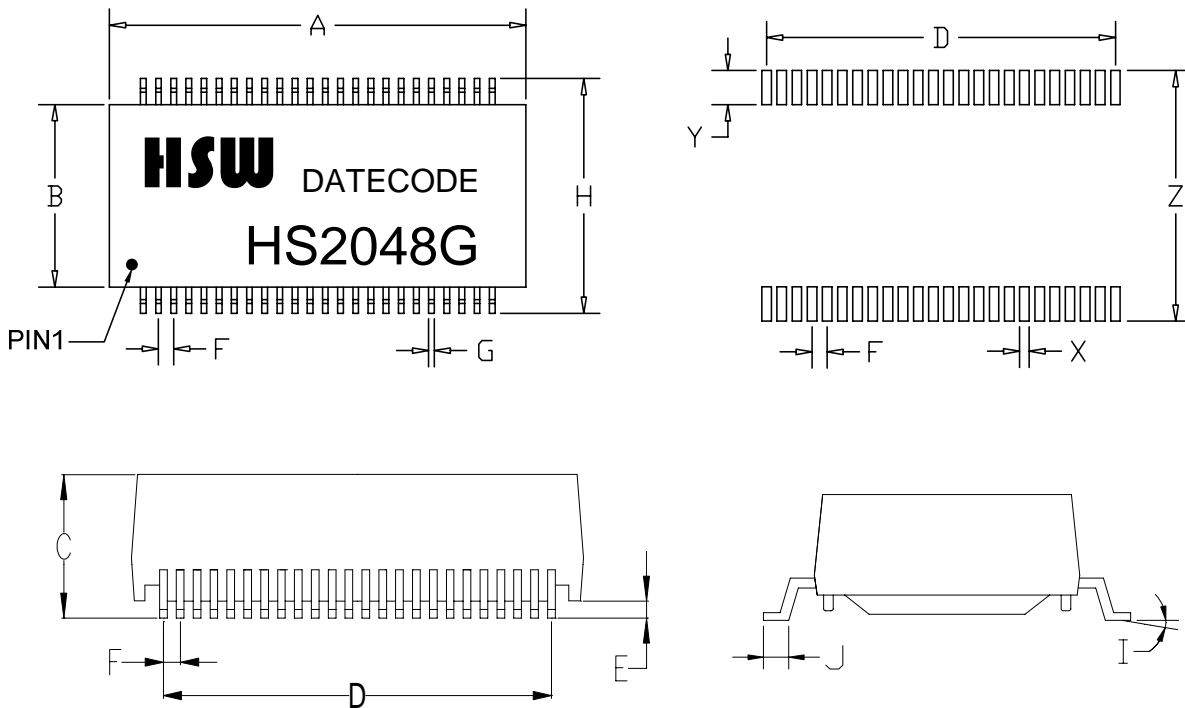

DIM	MILLIMETERS		INCHES	
	MIN	MAX	MIN	MAX
A	27.30	28.30	1.075	1.114
B	11.70	12.70	0.461	0.500
C	7.50 (max)		0.295 (max)	
D	23.46(Typical)		0.924(Typical)	
E	0.15	0.45	0.006	0.018
F	1.02(Typical)		0.040(Typical)	
G	0.38(Typical)		0.015(Typical)	
H	15.00	16.00	0.591	0.630
I	0°	8°	0°	8°
J	0.80	1.20	0.031	0.047
X	0.64(Typical)		0.025(Typical)	
Y	2.34(Typical)		0.092(Typical)	
Z	16.76(Typical)		0.660(Typical)	

D. PACKAGING:

- 1、 TUBE= 18 PCS
- 2、 INNER CARTON=40TUBE=40×18=720PCS
- 3、 EXPORT CARTON=4 INNER CARTON=4×720=2880PCS