



HSBRX21AP series

Manual

Renesas Electronics RX21A group MCU
HSB series MCU board

– Please read this carefully before using the product –

HokutoElectronic Co., Ltd.

REV.1.1.0.0

- Contents -

1 .	Notification.....	2
2 .	Safety Precaution	3
3 .	Outline	5
	3.1 Features	5
	3.2 Contents.....	5
	3.3 Specifications	5
	3.3.1 MCU board	5
	3.3.2 Connectors and Suitable connectors	6
4 .	Board Construction.....	7
	4.1 Block Diagram	7
	4.2 Board Layout	8
	4.3 Functions	9
	4.3.1 Low-pass filter sockets	9
	4.3.2 Delta-sigma A/D Converter BNC connectors	10
	4.3.3 SW1~4 Switches for evaluation	11
	4.3.4 SW5 Reset switch.....	11
	4.3.5 LEDs for evaluation	11
	4.3.6 J12 AVCCA power input selector	11
	4.3.7 J13 AVCC0 power input selector Unmounted.....	12
	4.3.8 J15 Enable control jumper for LED	12
	4.3.9 J16 Jumper for current measurement	12
	4.3.10 J17 AVCCA power input Unmounted	12
	4.3.11 J18 AVCC0 power input Unmounted.....	12
	4.3.12 J19~J29 Delta-sigma input selectors.....	13
	4.3.13 J30 Reset selecting jumper.....	13
	4.3.14 J1 Expansion I/O (50P) Unmounted Signal list.....	14
	4.3.15 J2 Expansion I/O (26P) Unmounted Signal list.....	15
	4.3.16 J3 Analog interface (40P) Unmounted Signal list	16
	4.3.17 J4 Emulator interface (14P) Connector signal list	16
	4.3.18 J5 FLASH interface (20P) Unmounted Signal list	17
	4.3.19 J6 Communication I/O (10P) Unmounted Signal list	17
5 .	Operating Mode	18
	5.1 Operating Mode	18
	5.2 Programming Internal ROM.....	18
	5.3 Pin Setting When Using Onboard Programmers.....	18
6 .	Appendix	19
	6.1 Board Measurement.....	19
	6.2 The Circuit Diagram of Switches and LEDs for evaluation.....	20
	6.2.1 Switches for evaluation.....	20
	6.2.2 LEDs for evaluation.....	20
	6.3 Revision History	21
	6.4 Inquiry	21

1. Notification

Please read this carefully before using the product.

【GENERAL PRECAUTIONS】

1. Please make sure to read this user's manual before using this product. This user's manual must be kept for when anything unclear arises from using this product, read this again until you fully understand.
2. This manual is constructed to explain the use of HokutoElectronic MCU board, so it does not cover the user system.
3. Copyright and the industrial property right protect this manual and the product, and all rights are the property of HokutoElectronic Co., Ltd. All rights are reserved. Duplicating, Copying, and reprinting this document are not allowed.
4. MCU boards in our products are designed based on the specifications of MCU. Please refer to MCU manufacturer for the specifications of MCU. Designs, functions and specifications of this product are subject to change without prior notice in order to improving its performance and safety. Please be advised that sometime the diagram in this manual may differ from the product.
5. In order to use the products, please have it well evaluation before.
6. We are not responsible for any parts that are not mounted on. Please use them on your own responsibility.

【GUARANTEE】

1. HokutoElectronic Co., Ltd. guarantee is valid that this product is used within the usage described in this manual, and has been produced correctly.
2. This product is guaranteed for 1 year after purchase.

【 GUARANTEE LIMITATION】

This guarantee is not valid in the following cases:

1. Product damage caused by fires, earthquakes, floods and third parties.
2. Product damage caused by premeditation, negligence, improper use, and/or in an improper environment.
3. The method of use has resulted in damage to the product or attachments.
4. Any remodeling, and repairing to the product or attachments.

【GENERAL DISCLAIMER】

HokutoElectronic Co., Ltd. guarantees the product only when the product is used correctly as described in this manual. The guarantee is valid only for the materials used to construct the product in their purchased state. HokutoElectronic Co., Ltd. accepts no responsibility for whatever costs associated directly (or indirectly) with damaged (or faulty) goods. This guarantee is valid for only the original purchaser of the product. The purchase of the product assumes all responsibility after the purchase of this product. Claims by third party users cannot be accepted. The price and the specification of the product and its attachments are subject to change without prior notice.

Note: "Renesas Electronics" as used in this manual means Renesas Electronics Corporation.

2. Safety Precaution





The following symbols provide important information for safety use. Always be sure to read and understand each precaution before moving on to the rest of the manual.

Signs mean:

 **WARNING** Improper use may result in death or serious injury

 **CAUTION** Improper use may cause slight injury or product damage.

Symbol Indications:

	<p>General Instruction This symbol indicates steps that users must follow.</p>		<p>General Prohibition This symbol indicates general prohibition.</p>
	<p>Unplugging power plugs This symbol indicates that power plugs need to be unplugged.</p>		<p>General Caution This symbol indicates general caution.</p>

WARNING



Failure to the following warnings may cause damage, smoke, and fire to products or user systems. Also it may result in broken the internal MCU program.

1. Do not plug/unplug cables while products or user systems are turned on.
2. Do not put/remove MCUs or ICs on user systems while products or user systems are turned on.
3. Use products or user systems within the specified voltage.
4. Confirm pin numbers on connectors and MCU connection on user system, and use products properly.



Stop using products when they smoke or smell.

Unplug the power source if products are power supplied. Continuing to use them may cause fire or electric shock.

 **CAUTION****Failure to followings may cause product damage.**

1. Do not directly touch mounted connectors or mounted parts on the boards. Static electricity may cause broken components.
2. Do not use or keep products in the following places.
 - Dusty, unstable, shaky, humid and magnetic places
 - Places exposed to direct sunlight, and near water
3. Do not drop, give a shock, and put something heavy on the board.
4. Do not put liquid such as water, and metal such as clip on products.
5. Do not eat or smoke near products.

**Some soldered places are sharply pointed on backside of board products.**

Hold edges of boards when putting on or taking out. The soldered place may cause slight injury.

**For your backups, make copies of provided CDs or floppy disks.**

In a case of losing those data, we do not guarantee on them.

**Do not turn off the power or reset the PC while access lamp is lighting up.**

It may cause products damage and data lost.

**Our products are not intended to be used with or control facilities or device concerning human lives, including medical devices, aeronautics and space devices, nuclear devices, and transportation devices; and facilities and devices requiring high liability.**

HokutoElectronic Co., Ltd. assumes no liability for any accident resulting in personal injury, fire, or property damage if the equipment has been used in the above conditions.

3. Outline

3.1 Features

This board has a mounted RX21A MCU which has flash memory, and is made by Renesas Electronics.

Key Features

- RX21A 100 pin count with a high quality 24 bit delta-sigma A/D converter
- 4 mounted LEDs and 4 switches for evaluation
- Oscillators 20 MHz, 32.768KHz
- Delta-sigma A/D converter interfaces
 - 4 channels of differential input, 3 channels of single-end input
 - 3 channels of BNC input (HSBRX21AP-B only)
- Low-pass filter sockets for delta-sigma A/D converter evaluation
- Power input and output interfaces
- 14 pin emulator interface (supports E1 · E20 of Renesas Electronics)
- 20 pin 2Mbps FLASH interface (supports our onboard programmers, FM-ONE · FLASH2)

3.2 Contents

This product is provided with the following. Please check the provided accessories before using this unit.

·MCU board.....	1
·CD (PDF manual).....	1
·Circuit diagram.....	1

3.3 Specifications

3.3.1 MCU board

Following MCU can be mounted on this board. Please check the part number of the mounted MCU.

MCU board part number	Mounted MCU part number	Internal ROM	E2 data flash	Internal RAM	Board power supply	MCU power supply width	Power consumption
HSBRX21AP or HSBRX21AP-B※1	R5F521A6BDFP	256K	8K	32K	1.8V ~ 3.3V ※2	1.8V~3.6V 2.7~3.6V	30mA All ports are open.
	R5F521A7BDFP	384K		64K			
	R5F521A8BDFP	512K		64K			

※1 BNC connectors are mounted only on HSBXR21AP-B.

※2 Reset circuit is 3.3V.

Clock	Board size
Main clock : 20MHz※3 Sub clock : 32.768KHz	73.00mm × 112.00mm (Not including projection)

※3 There are mounted sockets for oscillators, which are replaceable.



Make sure that the power supply polarity and voltage are correct.

- Use only one power source. Multiple power sources can cause product damage or broken components.
- Reverse voltage and high voltage may cause product damage, broken components, smoke and fire.
- Each terminal is not able to prevent the improper polarity and/or high voltage. When applying voltage, to avoid trouble, please set it between GND and VCC.

3.3.2 Connectors and Suitable connectors

Connector		Mounted connector	Maker	Pin	Suitable connector	Maker
J1	Expansion I/O	Unmounted	—	50	MIL standard	—
J2				26		
J3				40		
J4	Emulator interface ※1	H310-014P	Conser	14	FL14A2FO	OKI cable or standard
J5	FLASH interface※2	H310-020P	Conser	20	FL20A2FO	OKI cable or standard
J6	Communication I/O	Unmounted	—	10	MIL standard	—
J7	BNC connector※3	5227699-2	TE Connectivity	—	—	—
J8						
J9						
J10	Power input interface	ML-40S1BXF	Satoh Parts	4	—	—
J11	Power output interface	Unmounted	—	2	MIL standard	—

※1 Emulator interface supports E1 and E20. (Renesas Electronics)

※2 FLASH interface supports FM-ONE and FLASH 2. (Onboard programmers of HokutoElectronic)

※3 BNC connectors are mounted only on HSBRX21AP-B

4. Board Construction

4.1 Block Diagram

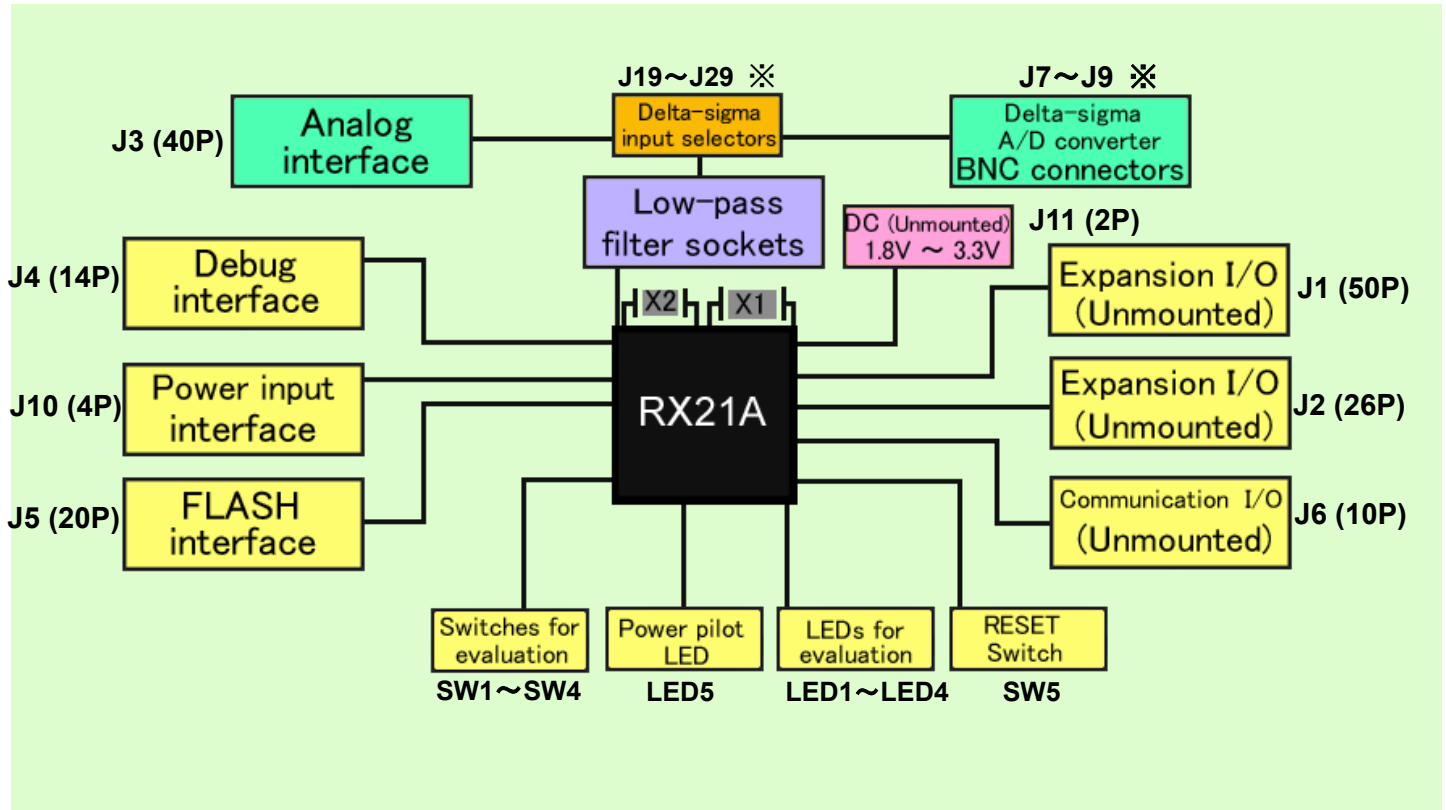

※Mounted only on HSBRX21AP-B.

4.2 Board Layout

J3
Analog interface
(40P)
Unmounted

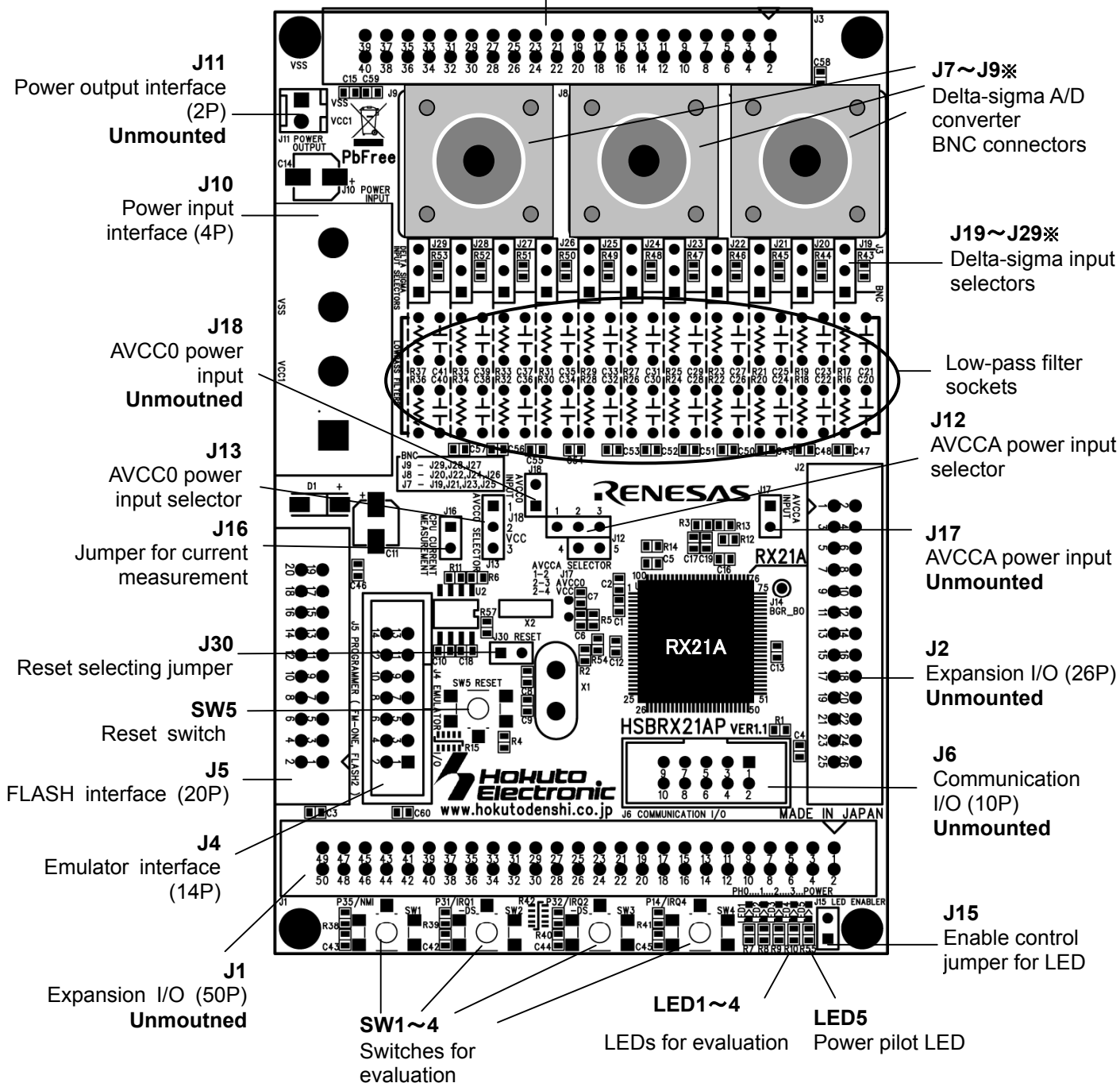

※Mounted only on HSBRX21AP-B.

4.3 Functions

4.3.1 Low-pass filter sockets

By placing capacitors and resistors into sockets, low-pass filters are constructed without soldering.

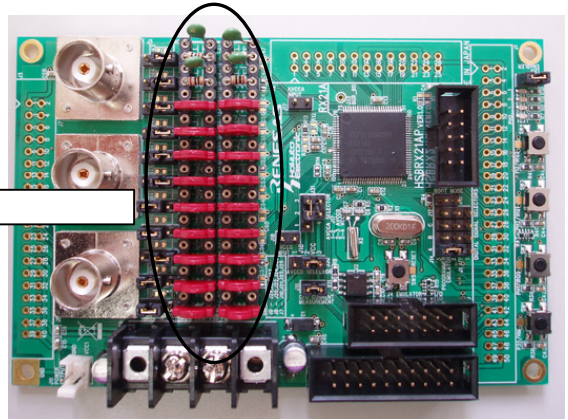
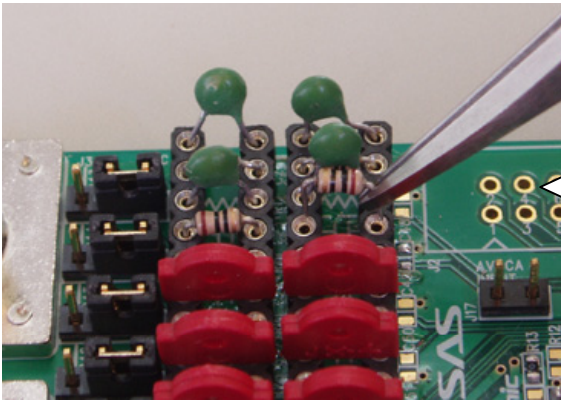

Any volume of capacitors and resistors can be placed into the sockets without soldering, as shown above.

※ Circled area is the low-pass filters. The capacitors and resistors are not included. The photo is demonstration only.

Size information of replaceable capacitors and resistors

- The width of the parts is under 2.5mm.
- The legs of the parts must be within 0.42~0.62mm across.

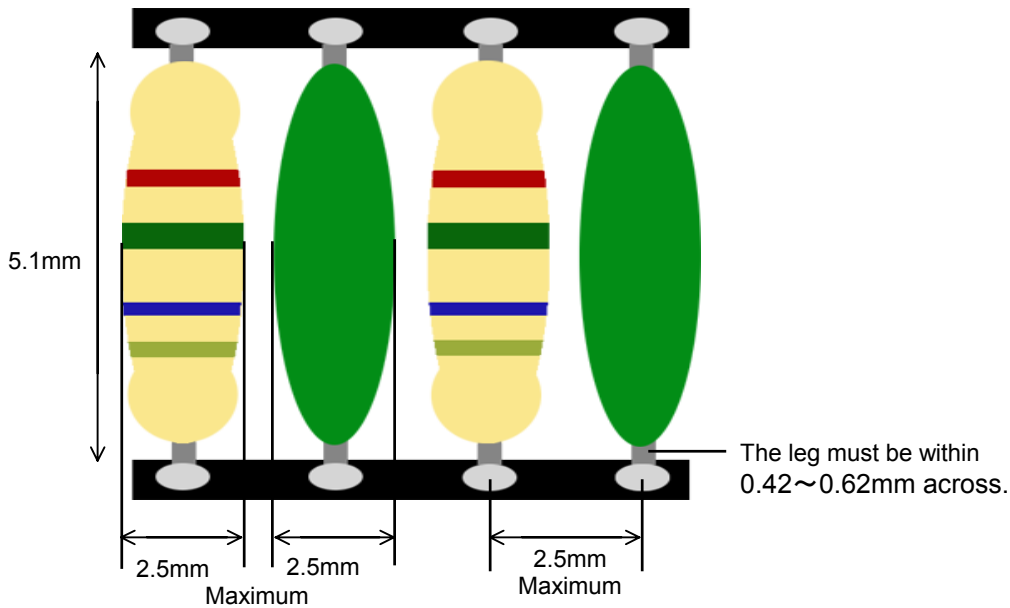

A portion of the low-pass filter circuit diagram

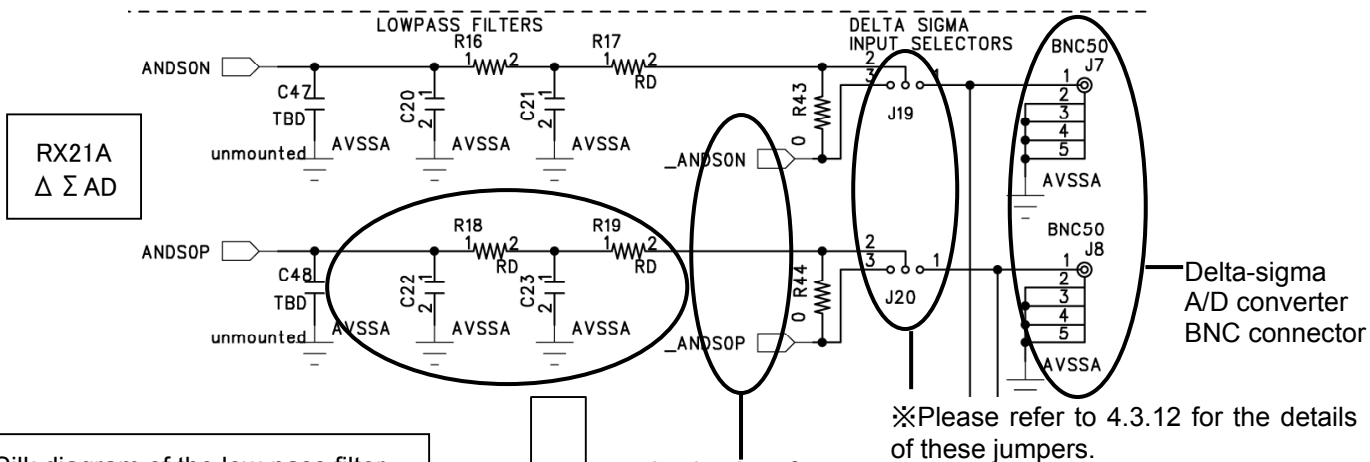

Silk diagram of the low-pass filter

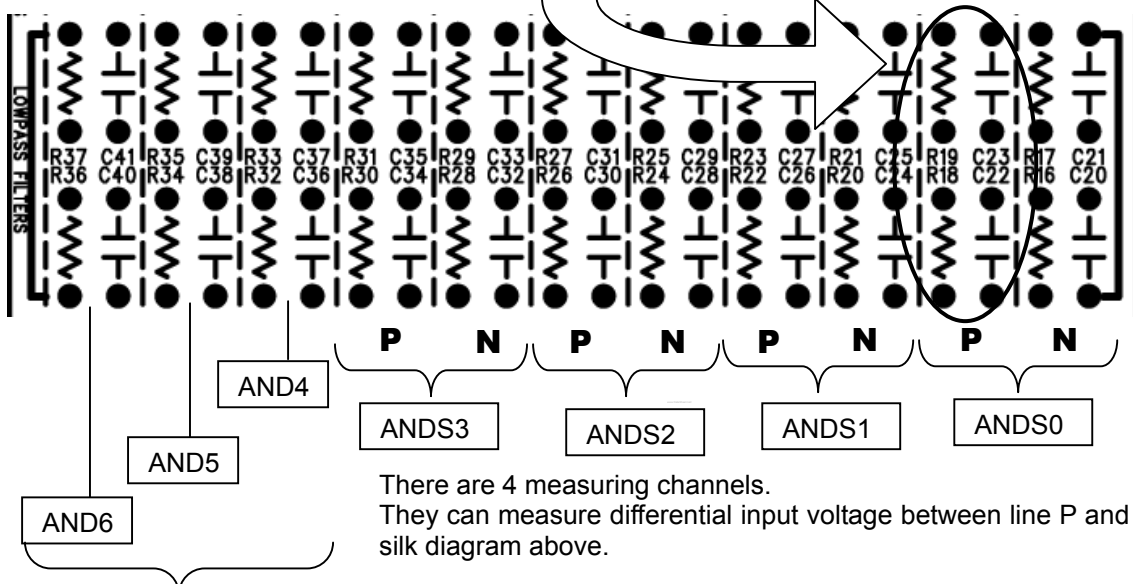

Those 3 channels are single-ends.

4.3.2 Delta-sigma A/D Converter BNC connectors

※Mounted only on HSBRX21AP-B.

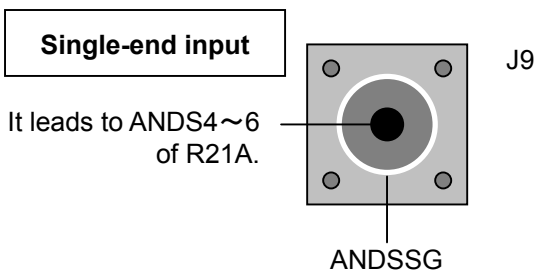

Shorted 1-2 on J27~J29

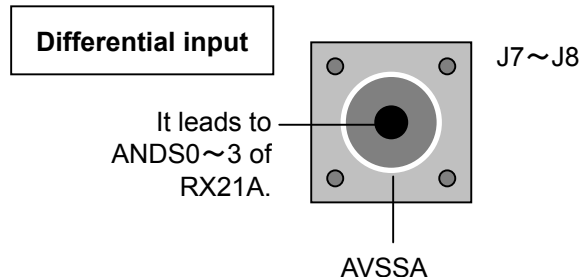

Shorted 1-2 on J19~J26

4.3.3 SW1~4 Switches for evaluation

Switch	MCU pin number	Signal name	Note
SW1	15	P35/NMI	Switches for evaluation (generates "L" signal by pressing)
SW2	19	P31/MTIOC4D/TMC12/*CTS1/*RTS1/*SS1/SSLB0/IRQ1-DS/RTCIC1	
SW3	18	P32/MTIOC0C/TMO3/TXD6/SRXD6/SSDA6/IRQ2-DS/RTCOUT/RTCIC2	
SW4	32	P14/MTIOC3A/MTCLKA/TMRI2/*CTS1/*RTS1/*SS1/IRQ4	

L=Low

4.3.4 SW5 Reset switch

Switch	MCU pin number	Signal name	Note
SW5	10	*RES	Reset

4.3.5 LEDs for evaluation

LED	MCU pin number	Signal name	Note
LED1	38	PH0/CACREF	LEDs for evaluation (illuminate with "L" signal)
LED2	37	PH1/TMO0/IRQ0	
LED3	36	PH2/TMRI0/IRQ1	
LED4	35	PH3/TMC10	

L=Low

4.3.6 J12 AVCCA power input selector

Jumper	Note	Preset position
J12	1-2 shorted : J17(Unmounted)	2-3 shorted
	2-3 shorted : AVCC0★	
	2-4 shorted : VCC	

※ Do not set other configurations.

Picture of jumper location

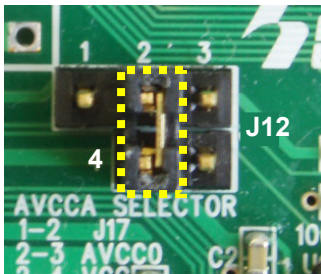

Please short 2 and 4 as shown on the left.

4.3.7 J13 AVCC0 power input selector Unmounted

Jumper	Note	Preset position
J13	1-2 shorted : J18 (Unmounted)	2-3 shorted
	2-3 shorted : VCC★	

4.3.8 J15 Enable control jumper for LED

Jumper	Note	Preset position
J15	Shorted : illuminates LED for evaluation	Shorted

4.3.9 J16 Jumper for current measurement

Jumper	Note	Preset position
J16	Shorted : measures MCU current	Shorted

4.3.10 J17 AVCCA power input Unmounted

Jumper	Note	Preset position
J17	Short : 1-2 short on J12 supplies the power on AVCCA through J17.	-



Follow the proper power supply sequence when supplying the power through J17.
Failure to follow the sequence may cause MCU damage.
Please refer to the MCU hardware manual for power supply sequence.

4.3.11 J18 AVCC0 power input Unmounted

Jumper	Note	Preset position
J18	Short: 1-2 short on J13 supplies the power on AVCC0 through J18.	-



Follow the proper power supply sequence when supplying the power through J18.
Failure to follow the sequence may cause MCU damage.
Please refer to the MCU hardware manual for power supply sequence.

4.3.12 J19~J29 Delta-sigma input selectors

※Mounted only on HSBRX21AP-B.

1-2 shorted (Left open)

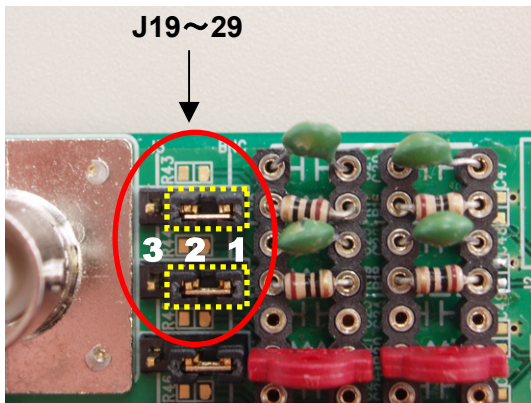

2-3 shorted (Right open)

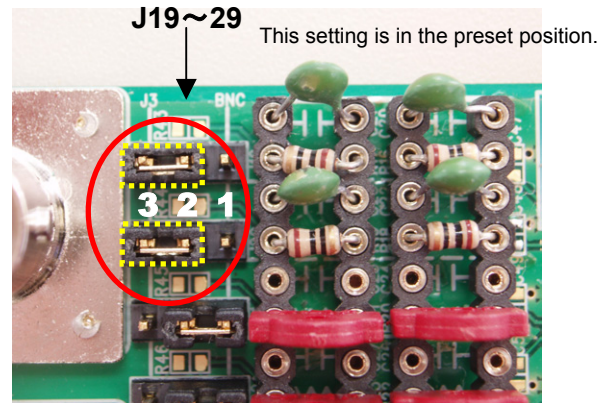

Delta-sigma input selectors	Input source		Signal name : Pin number of MCU
	BNC connectors (Input selectors 1-2 shorted)	J3 pin number (Input selectors 2-3 shorted)	
J19	J7	5	ANDS0N : 74
J20	J8	6	ANDS0P : 75
J21	J7	7	ANDS1N : 76
J22	J8	8	ANDS1P : 77
J23	J7	9	ANDS2N : 78
J24	J8	10	ANDS2P : 79
J25	J7	11	ANDS3N : 80
J26	J8	— 12	ANDS3P : 81
J27	J9	17	ANDS4 : 87
J28	J9	18	ANDS5 : 88
J29	J9	19	ANDS6 : 89

4.3.13 J30 Reset selecting jumper

Jumper	Note	Preset position
J30	Shorted : The mounted Reset IC is valid.	Shorted
	Opened : Power-on-reset is valid.	

4.3.14 J1 Expansion I/O (50P) Unmounted Signal list

An asterisk (*) indicates negative logic. NC means no connection.

No	MCU pin number	Signal name	No	MCU pin number	Signal name
1		NC	2		NC
3	50	PC2/MTIOC4B/RXD5/STXD5/SSCL5/SSLA3	4	49	PC3/MTIOC4D/TXD5/SRXD5/SSDA5
5	48	PC4/MTIOC3D/MTCLKC/TMCI1/*POE0/SCK5/*CTS8/*RTS8/*SS8/SSLA0	6	47	PC5/MTIOC3B/MTCLKD/TMRI2/SCK8/RSPCKA
7	46	PC6/MTIOC3C/MTCLKA/TMCI2/RXD8/STXD8/SSCL8/MOSIA	8	45	PC7/MTIOC3A/TMO2/MTCLKB/TXD8/SRXD8/SSDA8/MISOA/CACREF
9	44	P50/SSLB1	10	43	P51/SSLB2
11	42	P52/SSLB3	12	41	P53
13	40	P54/MTIOC4B/TMCI1	14	39	P55/MTIOC4D/TMO3
15	38	PH0/CACREF	16	37	PH1/TMO0/IRQ0
17	36	PH2/TMRI0/IRQ1	18	35	PH3/TMCI0
19	34	P12/TMCI1/SCL0/IRQ2	20	33	P13/MTIOC0B/TMO3/SDA0/IRQ3
21	32	P14/MTIOC3A/MTCLKA/TMRI2/*CTS1/*RTS1/*SS1/IRQ4	22	31	P15/MTIOC0B/MTCLKB/TMCI2/RXD1/STXD1/SCL1/IRQ5
23	30	P16/MTIOC3C/MTIOC3D/TMO2/TXD1/SRXD1/SSDA1/MOSIA/SCL0-DS/IRQ6/RTCOUT/*ADTRG0	24	29	P17/MTIOC3A/MTIOC3B/TMO1/*POE8/SCK1/MISOA/SDA0-DS/IRQ7
25	28	P20/MTIOC1A/TMRI0/SDA1	26	27	P21/MTIOC1B/TMCI0/SCL1
27	26	P22/MTIOC3B/MTCLKC/TMO0	28	25	P23/MTIOC3D/MTCLKD
29	24	P24/MTIOC4A/MTCLKA/TMRI1	30	23	P25/MTIOC4C/MTCLKB/*ADTRG0
31	22	P26/MTIOC2A/TMO1/TXD1/SRXD1/SSDA1/MOSIB	32	21	P27/MTIOC2B/TMCI3/SCK1/RSPCKB/FINEC
33	20	P30/MTIOC4B/TMRI3/*POE8/RXD1/STXD1/SSCL1/MISOB/IRQ0-DS/RTCIC0	34	19	P31/MTIOC4D/TMCI2/*CTS1/*RTS1/*SS1/SSLB0/IRQ1-DS/RTCIC1
35	18	P32/MTIOC0C/TMO3/TXD6/SRXD6/SSDA6/IRQ2-DS/RTCOUT/RTCIC2	36	17	P33/MTIOC0D/TMRI3/*POE3/RXD6/STXD6/SSCL6/IRQ3-DS
37	16	P34/MTIOC0A/TMCI3/*POE2/SCK6/IRQ4	38	15	P35/NMI
39	10	*RES	40	6	PJ1/MTIOC3A
41	4	PJ3/MTIOC3C/*CTS6/*RTS6/*SS6	42	2	P03/DA0
43	100	P05/DA1	44	98	P07/*ADTRG0
45		NC	46		NC
47		NC	48		NC
49		VCC1	50		VSS

4.3.15 J2 Expansion I/O (26P) Unmounted Signal list

An asterisk (*) indicates negative logic. NC means no connection.

No	MCU pin number	Signal name	No	MCU pin number	Signal name
1	72	PE6/MOSIB/IRQ6	2	71	PE7/MISOB/IRQ7-DS
3	70	PA0/MTIOC4A/SSLA1/CACREF/CMPA1	4	69	PA1/MTIOC0B/MTCLKC/SCK5/SSLA2/CVREFA
5	68	PA2/RXD5/STXD5/SSCL5/SSLA3/CMPA2	6	67	PA3/MTIOC0D/MTCLKD/RXD5/STXD5/SSCL5/IRQ6-DS/CMPB1
7	66	PA4/MTIOC5U/MTCLKA/TMRI0/TXD5/SRXD5/SSDA5/SSLA0/IRQ5-DS/CVREFB1	8	65	PA5/RSPCKA
9	64	PA6/MTIOC5V/MTCLKB/TMCI3/*POE2/*CTS5/*RTS5/*SS5/MOSIA/CVREFB0	10	63	PA7/MISOA
11	61	PB0/MTIOC5W/RXD6/STXD6/SSCL6/RSPCKA/CM PB0	12		NC
13	59	PB1/MTIOC0C/MTIOC4C/TMCI0/TXD6/SRXD6/SSDA6/IRQ4-DS	14	58	PB2/*CTS6/*RTS6/*SS6
15	57	PB3/MTIOC0A/MTIOC4A/TMO0/*POE3/SCK6	16	56	PB4/*CTS9/*RTS9/*SS9
17	55	PB5/MTIOC2A/MTIOC1B/TMRI1/*POE1/SCK9	18	54	PB6/MTIOC3D/RXD9/STXD9/SSCL9
19	53	PB7/MTIOC3B/TXD9/SRXD9/SSDA9	20	52	PC0/MTIOC3C/*CTS5/*RTS5/*SS5/SSLA1
21	51	PC1/MTIOC3A/SCK5/SSLA2	22		NC
23		VCC1	24		VCC1
25		VSS	26		VSS

4.3.16 J3 Analog interface (40P) Unmounted Signal list

An asterisk(*) indicates negative logic. NC means no connection.

No	MCU pin number	Signal name	No	MCU pin number	Signal name
1		AVCCA	2		AVSSA
3		NC	4		NC
5	74	ANDS0N	6	75	ANDS0P
7	76	ANDS1N	8	77	ANDS1P
9	78	ANDS2N	10	79	ANDS2P
11	80	ANDS3N	12	81	ANDS3P
13		NC	14		AVSSA
15		AVSSA	16		AVSSA
17	87	ANDS4	18	88	ANDS5
19	89	ANDS6	20		NC
21	90	ANDSSG	22	91	P43/AN3
23	92	P42/AN2	24	93	P41/AN1
25	95	P40/AN0	26		NC
27		AVCC0	28		AVSS0
29		NC	30		NC
31		NC	32		NC
33		NC	34		NC
35		NC	36		NC
37		VCC1	38		VCC1
39		VSS	40		VSS



When inputting power (VCC, VCC1, AVCC0 and AVCCA) from the expansion I/Os, there is a certain sequence that must be followed.

Failure to follow this sequence of the power supply may cause MCU damage.

Please refer to the MCU hardware manual for the specifications of the MCU.

4.3.17 J4 Emulator interface (14P) Connector signal list

An asterisk(*) indicates negative logic. NC means no connection.

No	MCU pin number	Signal name	No	MCU pin number	Signal name
1	21	P27/MTIOC2B/TMC13/SCK1/RSPCKB/FINEC	2		VSS
3		NC	4		NC
5	22	P26/MTIOC2A/TMO1/TXD1/SRXD1/SSDA1/MOSIB	6		NC
7	7	MD/FINED	8		VCC1
9		NC	10	45	PC7/MTIOC3A/TMO2/MTCLKB/TXD8/SRXD8/SSDA8/MISOA/CACREF
11	20	P30/MTIOC4B/TMRI3/*POE8/RXD1/STXD1/SSCL1/MISOB/IRQ0-DS/RTCIC0	12		VSS
13	10	*RES	14		VSS

4.3.18 J5 FLASH interface (20P) Connector signal list

An asterisk(*) indicates negative logic. NC means no connection.

FM-ONE and FLASH2 (Onboard programmers of HokutoElectronic) can be connected to this interface.

No	MCU pin number	Signal name	No	Signal name
1	10	*RES	2	VSS
3		NC	4	VSS
5	45	PC7/MTIOC3A/TMO2/MTCLKB/TXD8/SRXD8/SSDA8/MISOA/CACREF	6	VSS
7	7	MD/FINED	8	VSS
9		NC	10	VSS
11		NC	12	VSS
13		NC	14	VSS
15	22	P26/MTIOC2A/TMO1/TXD1/SRXD1/SSDA1/MOSIB	16	VSS
17	20	P30/MTIOC4B/TMRI3/*POE8/RXD1/STXD1/SSCL1/MISOB/IRQ0-DS/RTCIC0	18	VCC1
19	21	P27/MTIOC2B/TMCI3/SCK1/RSPCKB/FINEC	20	VCC1

4.3.19 J6 Communication I/O (10P) Unmounted Signal list

An asterisk(*) indicates negative logic. NC means no connection.

No	MCU pin number	Signal name	No	MCU pin number	Signal name
1		VSS	2	49	PC3/MTIOC4D/TXD5/SRXD5/SSDA5
3	51	PC1/MTIOC3A/SCK5/SSLA2	4	47	PC5/MTIOC3B/MTCLKD/TMRI2/SCK8/RSPCKA
5	50	PC2/MTIOC4B/RXD5/STXD5/SSCL5/SSLA3	6	46	PC6/MTIOC3C/MTCLKA/TMCI2/RXD8/STXD8/SSCL8/MOSIA
7	20	P30/MTIOC4B/TMRI3/*POE8/RXD1/STXD1/SSCL1/MISOB/IRQ0-DS/RTCIC0	8	22	P26/MTIOC2A/TMO1/TXD1/SRXD1/SSDA1/MOSIB
9		VCC1	10		VSS

4.3.20 J10 Power input interface (4P)

No	Signal name	Note
1	-	-
2	VCC1	+3.3V to VSS
3	VSS	-
4	-	-

- ⊗ Please be careful with the polarity.
- ⊗ For analog optimization, please use regulated power supply.



Please make sure that the amplitude of the input signal is always set between Vss~Vcc.
Please make sure that the amplitude of the analog signal is always set between AVSS0~AVCC0, and AVSSA~AVCCA.

Setting the signals over or under the range will cause permanent damage.

5. Operating Mode

Please refer to the MCU hardware manual for details of the MCU operating mode.

5.1 Operating Mode

RX21A has the 3 following modes.

1. Boot mode

In boot mode, user program can be written to internal ROM.

Connect our onboard programmer and FLASH interface (J5), or debugger and debug interface (J4) in order to program.

2. User boot mode

Please refer to the MCU hardware manual for the details.

3. Single-chip mode (Operating state)

In single-chip mode, the program can be operated. All I/O ports can be used as input and output ports.

5.2 Programming Internal ROM

Connect FM-ONE or FLASH2 (Onboard programmers of HokutoElectronic) to FLASH interface (J5) in order to program.

Please refer to each manual for usage.

When debugging through debug interface (J4), please use E1 or E20 (Renesas Electronics).

5.3 Pin Setting When Using Onboard Programmers

When connecting this board to our onboard programmers, you can set the MCU modes through them.

Pin	Setting	Connector	Connected Pin
FEW	Z	3	NC
MD0	L	5	PC7
MD1	L	7	MD
I/O0	Z	9	NC
I/O1	Z	11	NC
I/O2	Z	13	NC

Supported programmers : FM-ONE ·FLASH2

6. Appendix

6.1 Board Measurement

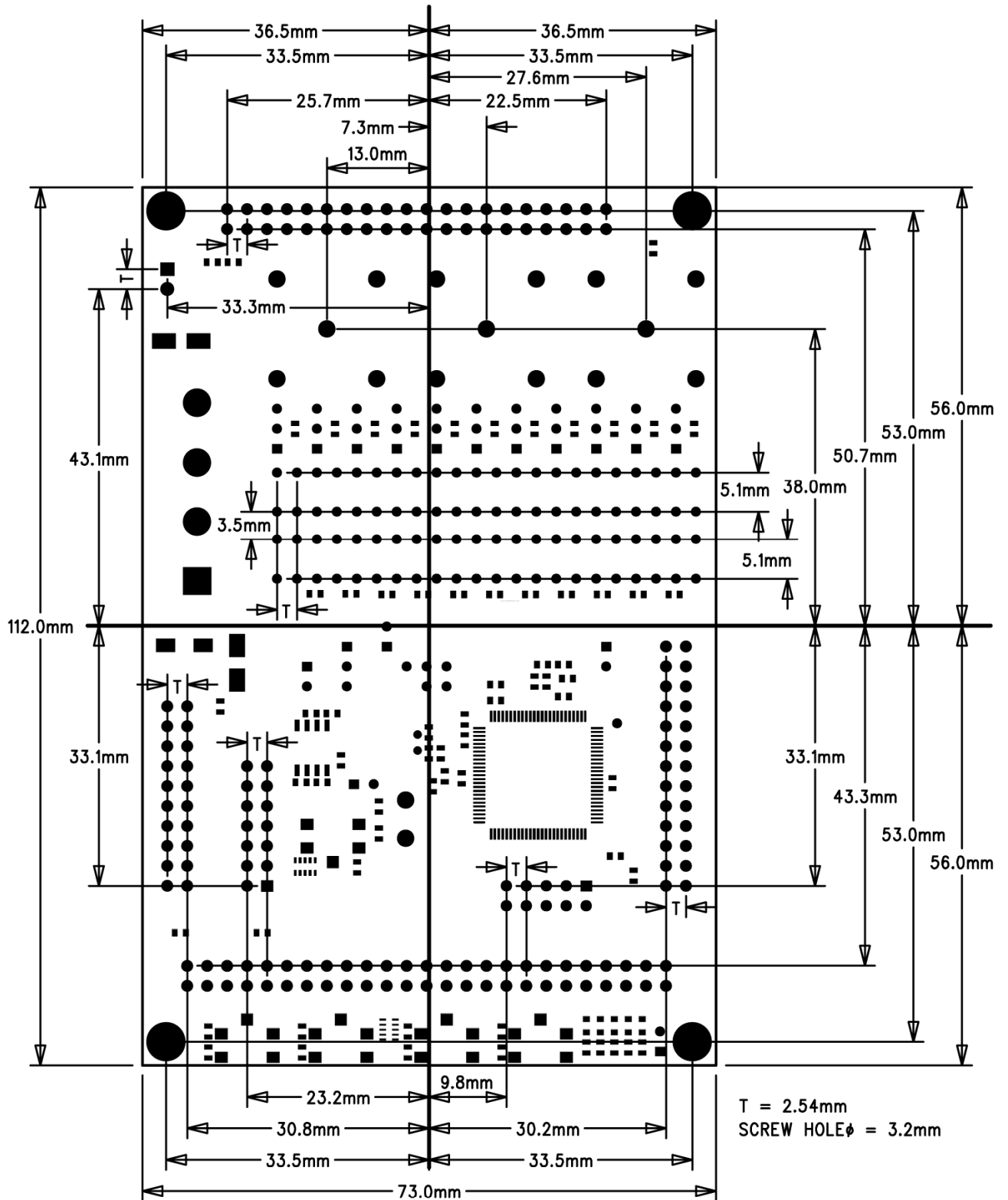

6.2 The Circuit Diagram of Switches and LEDs for evaluation

6.2.1 Switches for evaluation

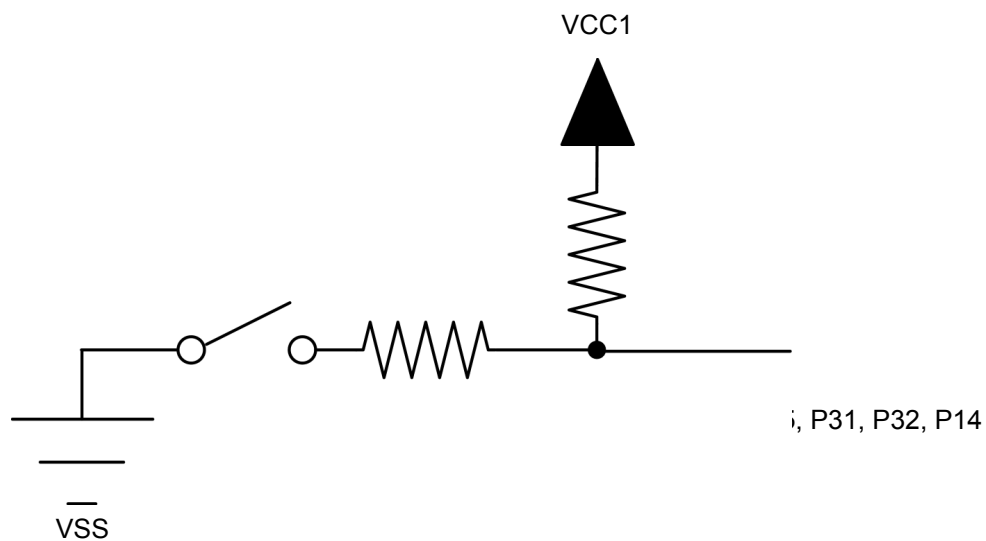

6.2.2 LEDs for evaluation

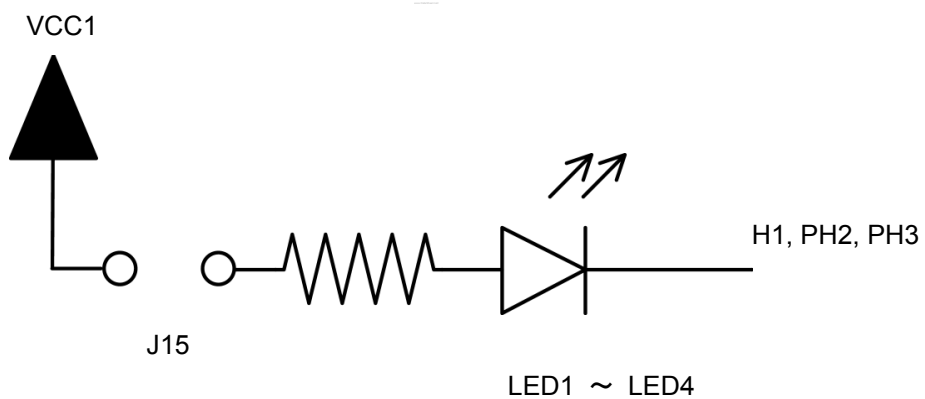

6.3 Revision History

Revision	Date	Page	Description
REV.1.0.0.0	2011.11.11	-	First Edition Issued
REV.1.0.1.0	2011.11.11	-	All pages revised.
REV.1.0.2.0	2011.11.25	17	“Unmounted” is added on J6 Signal list.
REV.1.1.0.0	2012.4.19	5	MCU part number changed.

6.4 Inquiry

Visit our web site for the latest information.

If you have any questions, feel free to contact us.

HokutoElectronic Co., Ltd.

〒060-0042 Odori-Nishi 16-chome, Chuoku, Sapporo, Hokkaido, Japan

TEL +81-011-640-8800 **FAX** +81-011-640-8801

e-mail: support@hokutoelectronic.com (Technical support), order@hokutoelectronic.com (Order and Inquiry)

URL: <http://www.hokutoelectronic.com>

Renesas Electronics RX21A group MCU
HSB series MCU board

HSBRX21AP series Manual

HokutoElectronic Co., Ltd.

©2011 HokutoElectronic Printed in Japan 2011.11.11 First printed. REV.1.1.0.0 (120419)
