

Document Title	HSD070I651-F00 CAS for Zenitron	Page No.	1/ 23
Document No.		Revision	1.0

TO : Zenitron

Date : 2008/02/22

Customer Acceptance Specification

**Model : HSD070I651
-F00**

Accepted by:

Signature	Date
_____	_____

Proposed by: Technical Service Division

Signature	Date
_____	_____

Note:1. Please contact HannStar Display Corp. before designing your product based on this module specification.

2.The information contained herein is presented merely to indicate the characteristics and performance of our products. No responsibility is assumed by HannStar for any intellectual property claims or other problems that may result from application based on the module described herein.

Document Title	HSD070I651-F00 CAS for Zenitron	Page No.	2/ 23
Document No.		Revision	1.0

Record of Revisions

Rev.	Date	Sub-Model	Description of change
1.0	Feb,22, 2008	F00	Preliminary Product Specification was first issued.

The information contained in this document is the exclusive property of HannStar Display Corporation. It shall not be disclosed, distributed or reproduced in whole or in part without written permission of HannStar Display Corporation.

Document Title	HSD070I651-F00 CAS for Zenitron	Page No.	3/ 23
Document No.		Revision	1.0

Contents

1.0	General description	p.4
2.0	Absolute maximum ratings	p.5
3.0	Optical characteristics	p.6
4.0	Block diagram	p.10
5.0	Interface pin connection	p.11
6.0	Electrical characteristics	p.12
7.0	Reliability test items.....	p.18
8.0	Outline dimension	p.19
9.0	Lot mark	p.20
10.0	Package specification	p.21
11.0	General precaution	p.22

The information contained in this document is the exclusive property of HannStar Display Corporation. It shall not be disclosed, distributed or reproduced in whole or in part without written permission of HannStar Display Corporation.

Document Title	HSD070I651-F00 CAS for Zenitron	Page No.	4/ 23
Document No.		Revision	1.0

1.0 GENERAL DESCRIPTION

1.1 Introduction

HannStar Display model HSD070I651-F is a color active matrix thin film transistor (TFT) liquid crystal display (LCD) that uses amorphous silicon TFT as a switching device. This model is composed of a TFT LCD panel, a driving circuit and a back light system. This TFT LCD has a 7.0 (16:9) inch diagonally measured active display area with 1440 x 234 dot (480 horizontal by 234 vertical pixel) resolution.

1.2 Features

- 7 (16:9 diagonal) inch configuration
- Compatible with NTSC & PAL system
- Image Reversion: UP/DOWN and LEFT/RIGHT
- RoHS Compliance

1.3 Applications

- Digital Photo frame
- Portable DVD
- Multimedia applications and Others AV system

1.4 General information

Item	Specification	Unit
Outline Dimension	164.9 x 100 x 5.5 (Typ.)	mm
Display area	154.08(H) x 86.58(V)	mm
Number of Pixel	480 RGB(H) x234(V)	pixels
Pixel pitch	0.321(H) x 0.370(V)	mm
Pixel arrangement	RGB Vertical stripe	
Display mode	Normally white	
Surface treatment	Antiglare, Hard-Coating(3H) with EWV film	
Weight	160 (Typ.)	g
Back-light	Single LED (Side-Light type)	
Power Consumption	B/L System 1.2(Max.)	W

1.5 Mechanical Information

Item	Min.	Typ.	Max.	Unit	
Module Size	Horizontal(H)	164.4	164.9	165.4	mm
	Vertical(V)	99.5	100.0	100.5	mm
	Depth(D)	—	5.7	6.0	mm
Weight (Without inverter)	—	160	—	g	

Document Title	HSD070I651-F00 CAS for Zenitron	Page No.	5/ 23
Document No.		Revision	1.0

2.0 ABSOLUTE MAXIMUM RATINGS

2.1 Electrical Absolute Rating

2.1.1 TFT LCD Module

Item	Symbol	Min.	Max.	Unit	Note
Power supply voltage	DV_{DD}	-0.3	6.0	V	GND=0
	V_{GH}	-0.3	15	V	GND=0
	V_{GL}	-10	0.3	V	GND=0
	$V_{GH} - V_{GL}$	-10	15	V	
	AV_{DD}	-0.3	7.0	V	AGND=0
	V_{COM}	-1.6	5.2	V	
Analog Signal Input Level	V_R, V_G, V_B	-0.2	$AV_{DD}+0.2$	V	
Logic Signal Input Level	V_I	-0.3	$DV_{DD} +0.3$	V	

2.1.2 Back-Light Unit

Item	Symbol	Typ.	Max.	Unit	Note
LED current	I_L	--	100	mA	(1) (2)
LED voltage	V_L	10.5	12	V	(1) (2)(3)

Note (1) Permanent damage may occur to the LCD module if beyond this specification. Functional operation should be restricted to the conditions described under normal operating conditions.

(2) $T_a = 25 \pm 2^\circ\text{C}$

(3) Test Condition: LED current 100 mA

2.2 Environment Absolute Rating

Item	Symbol	Min.	Max.	Unit	Note
Operating Temperature	T_{opa}	-20	70	$^\circ\text{C}$	
Storage Temperature	T_{stg}	-30	80	$^\circ\text{C}$	

Document Title	HSD070I651-F00 CAS for Zenitron	Page No.	6/ 23
Document No.		Revision	1.0

3.0 OPTICAL CHARACTERISTICS

3.1 Optical specification

Item		Symbol	Condition	Min.	Typ.	Max.	Unit	Note
Contrast		CR	$\Theta=0$	400	500	—		(1)(2)
Response time	Rising	T_R		—	5	7	msec	(1)(3)
	Falling	T_F		—	20	28		
White luminance (Center)		Y_L	Normal viewing angle	160	200	—	cd/m ²	(1)(4) ($I_L=100mA$)
Color chromaticity (CIE1931)	White	W_x		0.260	0.310	0.360		(1)(4)
		W_y	0.280	0.330	0.380			
Viewing angle	Hor.	Θ_L	CR>10	60	70	—		
		Θ_R		60	70	—		
	Ver.	Θ_U		50	60	—		
		Θ_D		60	70	—		
Brightness uniformity		B_{UNI}	$\Theta=0$	70	—	—	%	(5)
Optima View Direction		6 O' clock						(6)

3.2 Measuring Condition

- Measuring surrounding : dark room
- LED current I_L : 100mA
- Ambient temperature : 25±2°C
- 30min. warm-up time.

3.3 Measuring Equipment

- FPM520 of Westar Display technologies, INC., which utilized SR-3 for Chromaticity and BM-5A for other optical characteristics.
- Measuring spot size : 20 ~ 21 mm

Document Title	HSD070I651-F00 CAS for Zenitron	Page No.	7/ 23
Document No.		Revision	1.0

Note (1) Definition of Viewing Angle :

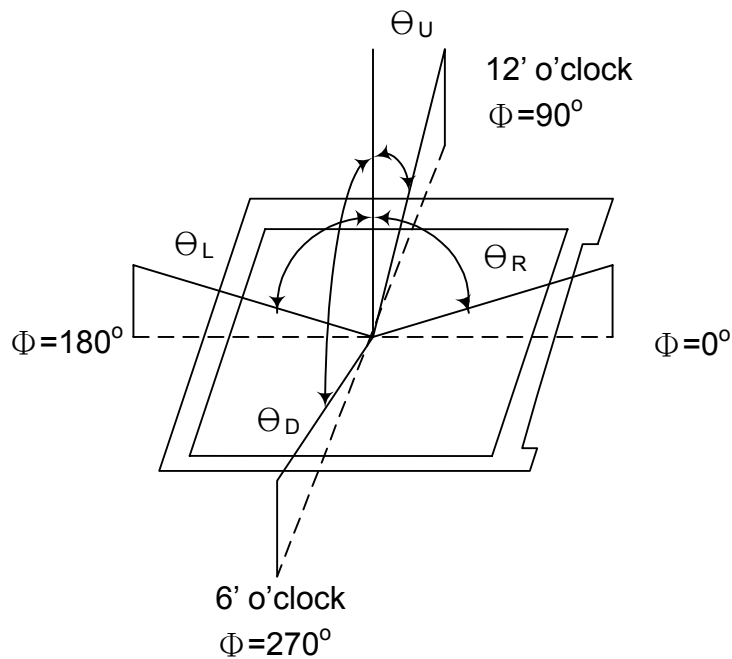

Note (2) Definition of Contrast Ratio(CR) :
measured at the center point of panel

$$CR = \frac{\text{Luminance with all pixels white}}{\text{Luminance with all pixels black}}$$

Note (3) Definition of Response Time : Sum of T_R and T_F

Document Title	HSD070I651-F00 CAS for Zenitron	Page No.	8/ 23
Document No.		Revision	1.0

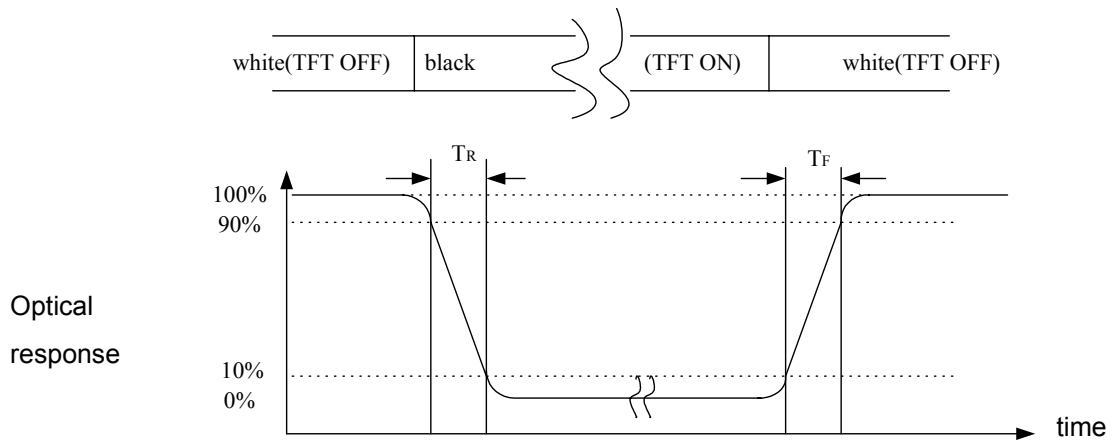

Note (4) Definition of optical measurement setup

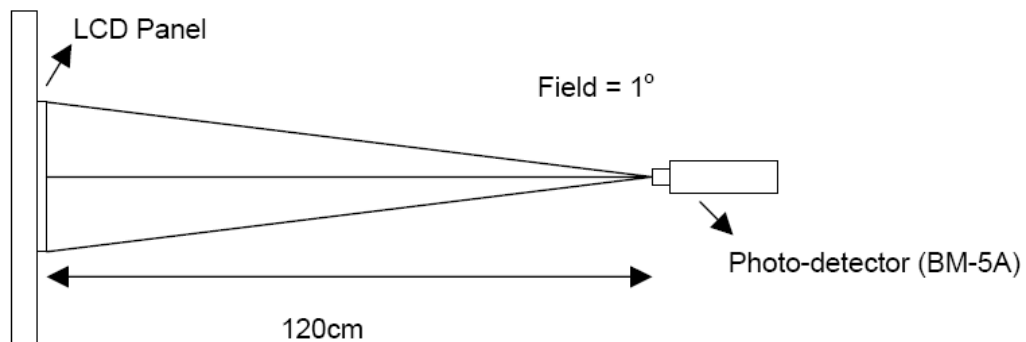

Document Title	HSD070I651-F00 CAS for Zenitron	Page No.	9/ 23
Document No.		Revision	1.0

Note (5) Definition of brightness uniformity

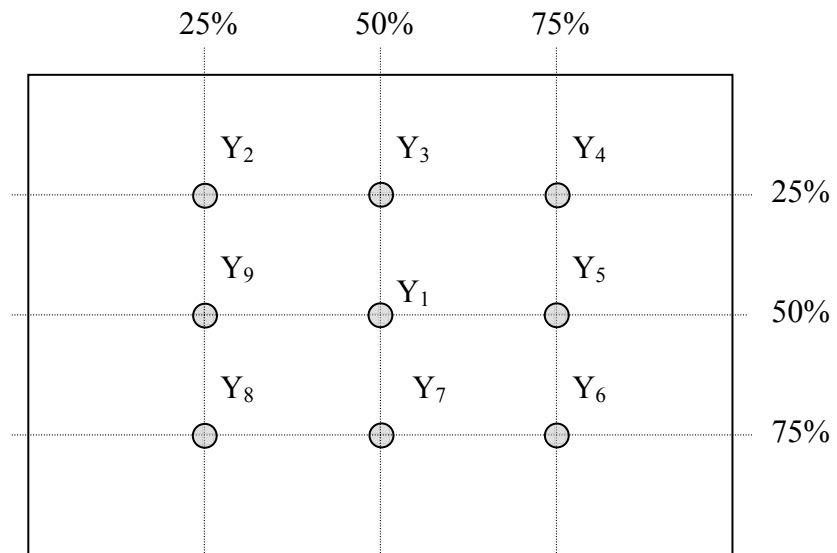

$$\text{Luminance uniformity} = \frac{\text{(Min Luminance of 9 points)}}{\text{(Max Luminance of 9 points)}} \times 100\%$$

Note (6) Rubbing Direction (The different Rubbing Direction will cause the different optima view direction.)

Document Title	HSD070I651-F00 CAS for Zenitron	Page No.	10/ 23
Document No.		Revision	1.0

4.0 BLOCK DIAGRAM

4.1 TFT LCD Module

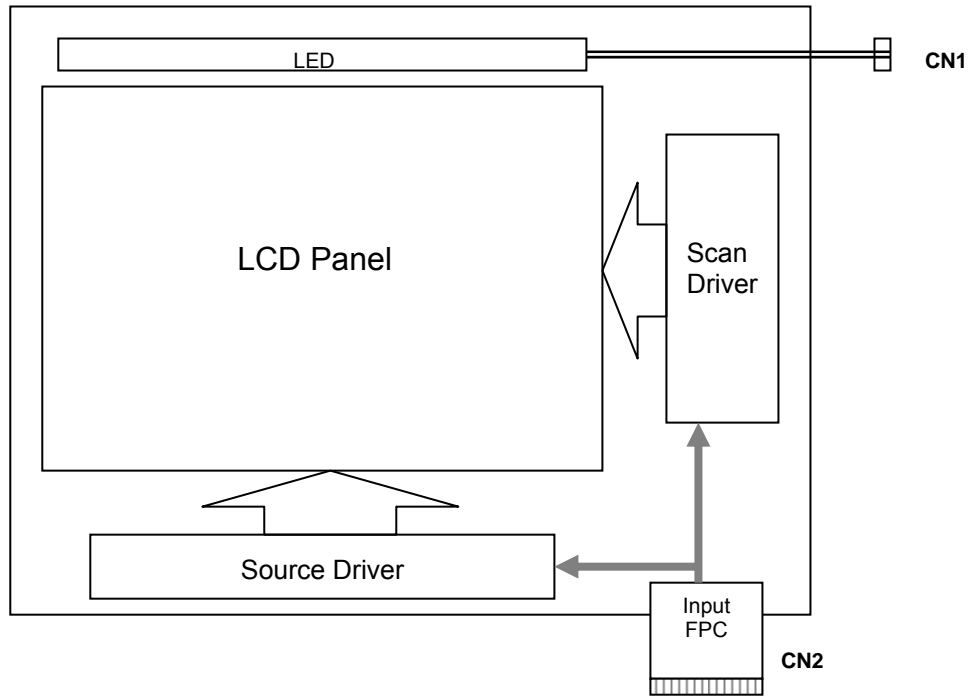

4.2 Pixel Format

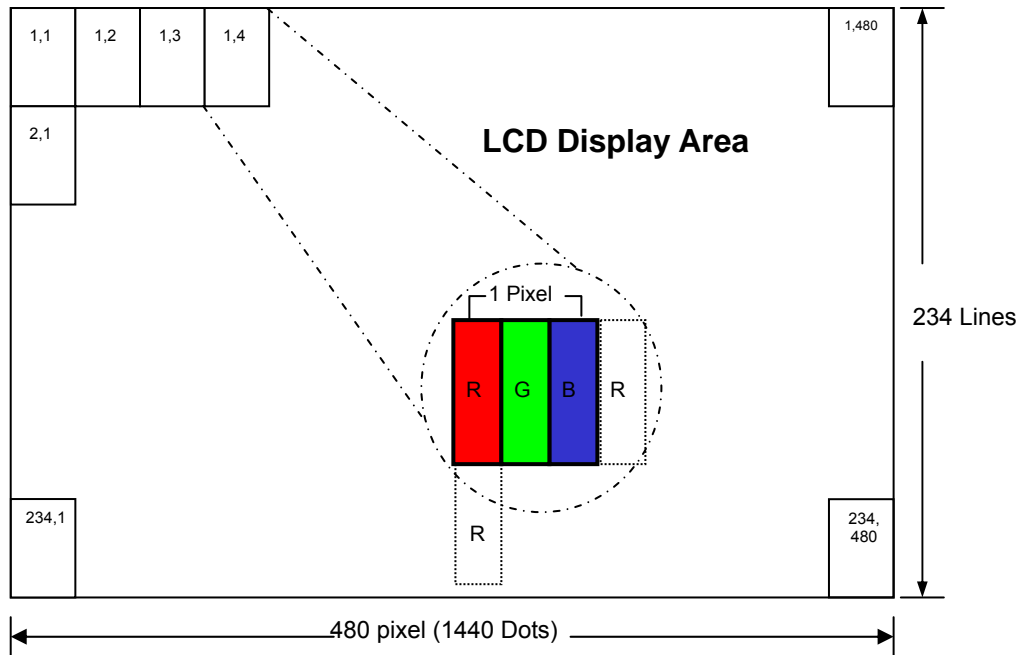

The information contained in this document is the exclusive property of HannStar Display Corporation. It shall not be disclosed, distributed or reproduced in whole or in part without written permission of HannStar Display Corporation.

Document Title	HSD070I651-F00 CAS for Zenitron	Page No.	11/ 23
Document No.		Revision	1.0

5.0 INTERFACE PIN CONNECTION

5.1 TFT LCD Module

CN2 (Input signal): FPC Down Connector, 26 pins, pitch: 0.5mm

Terminal no.	Symbol	I/O	Function	Note
1	DGND	-	Ground for logic circuit	
2	DV _{DD}	I	Supply voltage of logic control circuit for scan (Gate) driver	
3	V _{GL}	I	Negative power for scan (Gate) driver	
4	V _{GH}	I	Positive power for scan (Gate) driver	
5	STVD	I/O	Vertical start pulse	(1)
6	STVU	I/O	Vertical start pulse	(1)
7	CKV	I	Shift clock input for scan (Gate) driver	
8	U/D	I	UP/DOWN scan control input	(1)
9	OEV	I	Output enable input for scan(Gate) driver	
10	V _{COM}	I	Common electrode driving signal	
11	V _{COM}	I	Common electrode driving signal	
12	L/R	I	LEFT/RIGHT scan control input	(1)
13	MOD	I	Sequential sampling and simultaneous sampling setting	(2)
14	OEH	I	Output enable input for data (Source) driver	
15	STHL	I/O	Start pulse for horizontal scan (Gate) line	(1)
16	STHR	I/O	Start pulse for horizontal scan (Gate) line	(1)
17	CPH3	I	Sampling and shifting clock pulse for data (Source) driver	(2)
18	CPH2	I	Sampling and shifting clock pulse for data (Source) driver	(2)
19	CPH1	I	Sampling and shifting clock pulse for data (Source) driver	
20	DV _{DD}	I	Supply voltage of logic control circuit for data(Source) driver	
21	DGND	-	Ground for logic circuit	
22	V _R	I	Alternated video signal input(Red)	
23	V _G	I	Alternated video signal input(Green)	
24	V _B	I	Alternated video signal input(blue)	
25	AV _{DD}	I	Supply voltage for analog circuit	
26	AGND	-	Ground for analog circuit	

Note (1) Selection of scanning mode (please refer to the following table)

Setting of scan control input		IN/OUT state for start pulse				Scanning direction
U/D	L/R	STVD	STVU	STHR	STHL	
GND	DV _{DD}	Output	Input	Output	Input	up to down, and from left to right.
DV _{DD}	GND	Input	Output	Input	Output	down to up, and from right to left.
GND	GND	Output	Input	Input	Output	up to down, and from right to left.
DV _{DD}	DV _{DD}	Input	Output	Output	Input	down to up, and from left to right.

Note (2) MOD=H: Simultaneous sampling.(Please check CPH2 and CPH3 to GND when MOD=H)
 MOD=L: Sequential sampling.

Document Title	HSD070I651-F00 CAS for Zenitron	Page No.	12/ 23
Document No.		Revision	1.0

5.2 Back-Light Unit

CN1 LED Power Source (BHSR-02VS-1) / JAPAN SOLDERLESS TERMINAL MFG CO., LTD.
Mating Connector: **(SBHT-002T-P0.5) / JAPAN SOLDERLESS TERMINAL MFG CO., LTD.**

Terminal no.	Symbol	Function
1	VL	LED power supply (high voltage)
2	GL	LED power supply (low voltage)

6.0 ELECTRICAL CHARACTERISTICS

6.1 TFT LCD Module

Item	Symbol	Min.	Typ.	Max.	Unit	Note
Supply Voltage	DV_{DD}	3	3.3	5.5	V	
	V_{GH}	14.3	15	15.7	V	
	V_{GL}	-10.5	-10	-9.5	V	
	AV_{DD}	4.5	5	5.5	V	
Video signal amplitude (VR, VG, VB)	V_{iA}	0.4	-	$AV_{DD}-0.4$	V	
	V_{iAC}	-	3	-	V	AC component,
	V_{iDC}	-	$AV_{DD}/2$	-	V	DC component
VCOM	V_{CAC}		5.5		VP-P	AC component
	V_{CDC}	1.6	1.8	2.0	V	DC component, (1)
Input signal voltage	V_{iH}	$0.8DV_{DD}$	-	DV_{DD}	V	(2)
	V_{iL}	0	-	$0.2 DV_{DD}$	V	(2)
Current of power supply	I_{DD}	-	4.2	-	mA	$DV_{DD} = 3.3V$
	I_{ADD}	-	3.7	-	mA	$AV_{DD} = 5V(\text{Black})$
	I_{GH}	-	60	-	μA	$V_{GH} = 15V$
	I_{GL}	-	400	-	μA	$V_{GL} = -10V$

Note (1): The brightness of LCD panel could be changed by adjusting the AC component of V_{COM} .

Note (2): STHL, STHR, OEH, L/R, CPH1~CPH3, STVD, STVU, OEV, CKV, U/D

Note (3): Be sure to apply the power voltage as the power sequence spec.

Note (4) : DGND=AGND=0V,)

Document Title	HSD070I651-F00 CAS for Zenitron	Page No.	13/ 23
Document No.		Revision	1.0

6.2 Back-Light Unit

The back-light system is an edge-lighting type with 15 LED.

The characteristics of the LED is shown in the following tables.

Item	Symbol	Min.	Typ.	Max.	Unit	Note
LED current	IL	—	—	100	mA	
LED voltage	VL	—	10.5	12	V	
Operating LED life time	Hr	20,000	—	—	Hour	(1)

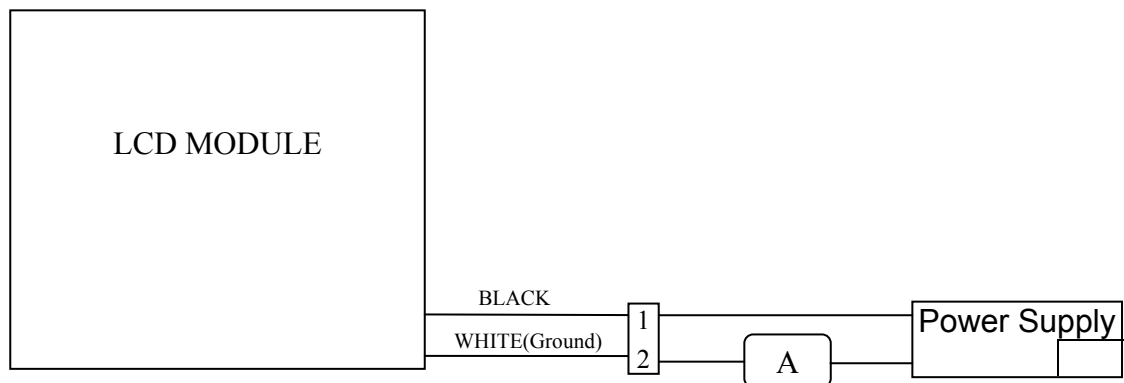

Note (1) LED life time (Hr)

can be defined as the time in which it continues to operate under the condition : $T_a=25\pm 3^\circ\text{C}$, typical IL value indicated in the above table until the brightness becomes less than 50%.

Document Title	HSD070I651-F00 CAS for Zenitron	Page No.	14/ 23
Document No.		Revision	1.0

6.3 AC Characteristics

Item	Symbol	Min.	Typ.	Max.	Unit	Note
Rising time	t_r	-	-	10	ns	(1)
Falling time	t_f	-	-	10	ns	(1)
High and low level pulse duty	t_{CPH}	100	103	-	ns	CPH1~CPH3
CPH pulse duty	t_{CWH}	40	50	60		CPH1~CPH3
STH setup time	t_{SUH}	20	-	-	ns	STHR,STHL
STH hold time	t_{HDH}	10	-	-	ns	STHR,STHL
STH pulse width	t_{STH}	-	1	-	t_{CPH}	STHR,STHL
STH period	t_H	61.5	63.5	65.5	μs	STHR,STHL
OEH pulse width	t_{OEH}	-	1.23	-	μs	OEH
Sample and hold disable time	t_{DIS1}	-	8.19	-	μs	
OEV pulse width	t_{OEV}	-	4.77	-	μs	OEV
CKV pulse width	t_{CKV}	-	3.91	-	μs	CKV
Clean enable time	t_{DIS2}	-	3.90	-	μs	
Horizontal display timing range	t_{DH}	-	1440	-	$t_{CPH}/3$	
STV setup time	t_{SUV}	200	-	-	ns	STVD,STVU
STV hold time	t_{HDV}	300	-	-	ns	STVD,STVU
STV pulse width	t_{STV}	-	1	-	t_H	STVD,STVU
Horizontal line per field	t_V	256	262	268	t_H	(2)
Vertical display start	t_{SV}		3	-	t_H	
Vertical display timing range	t_{DV}		234	-	t_H	
VCOM Rising time	t_{COM}		-	5	μs	
VCOM Falling time	t_{COM}		-	5	μs	
VCOM delay time	t_{DCOM}		-	3	μs	
RGB delay time	t_{DRGB}		*	1	μs	

Note (1): For all of the logic signals.

Note (2): Please don't use odd horizontal lines to drive LCD panel for both odd and even filed simultaneously.

Document Title	HSD070I651-F00 CAS for Zenitron	Page No.	15/ 23
Document No.		Revision	1.0

6.4 Timing Diagram of Interface Signal

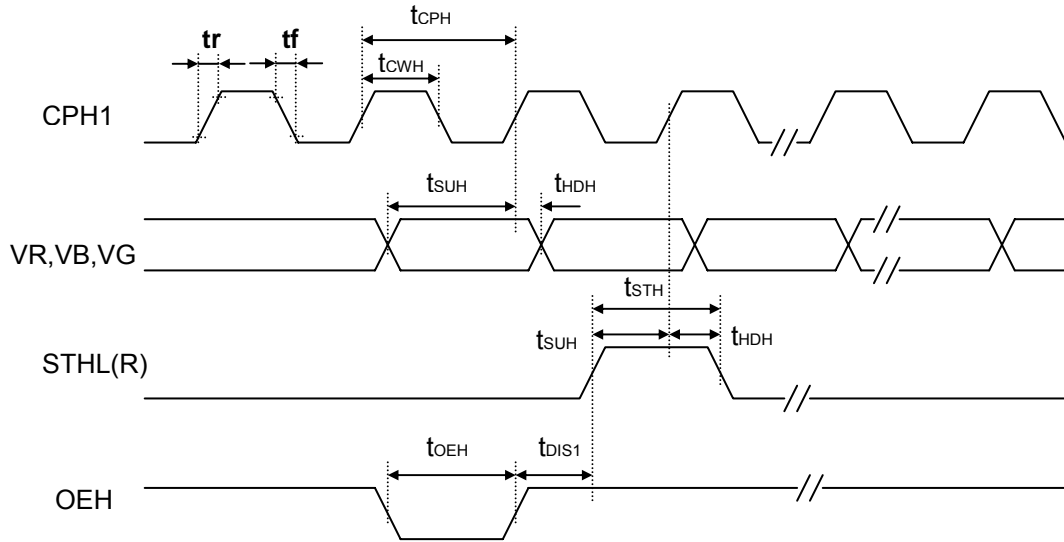

Sampling clock timing

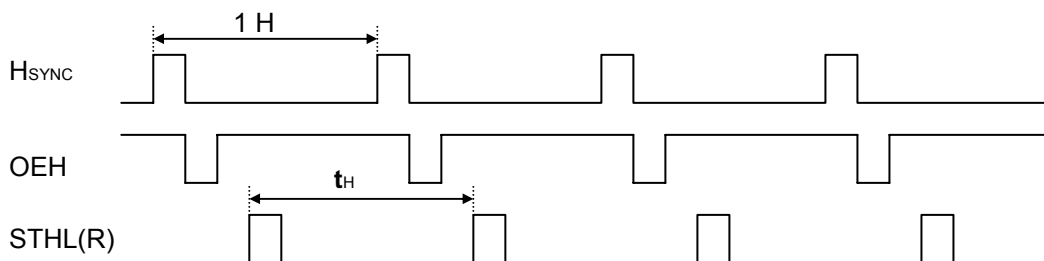
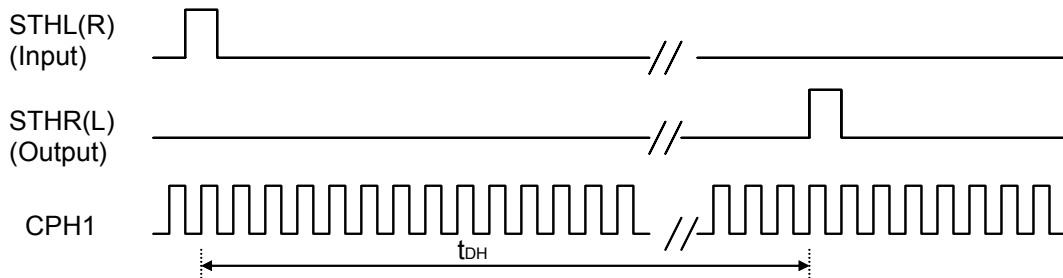

Horizontal display timing range

The information contained in this document is the exclusive property of HannStar Display Corporation. It shall not be disclosed, distributed or reproduced in whole or in part without written permission of HannStar Display Corporation.

Document Title	HSD070I651-F00 CAS for Zenitron	Page No.	16/ 23
Document No.		Revision	1.0

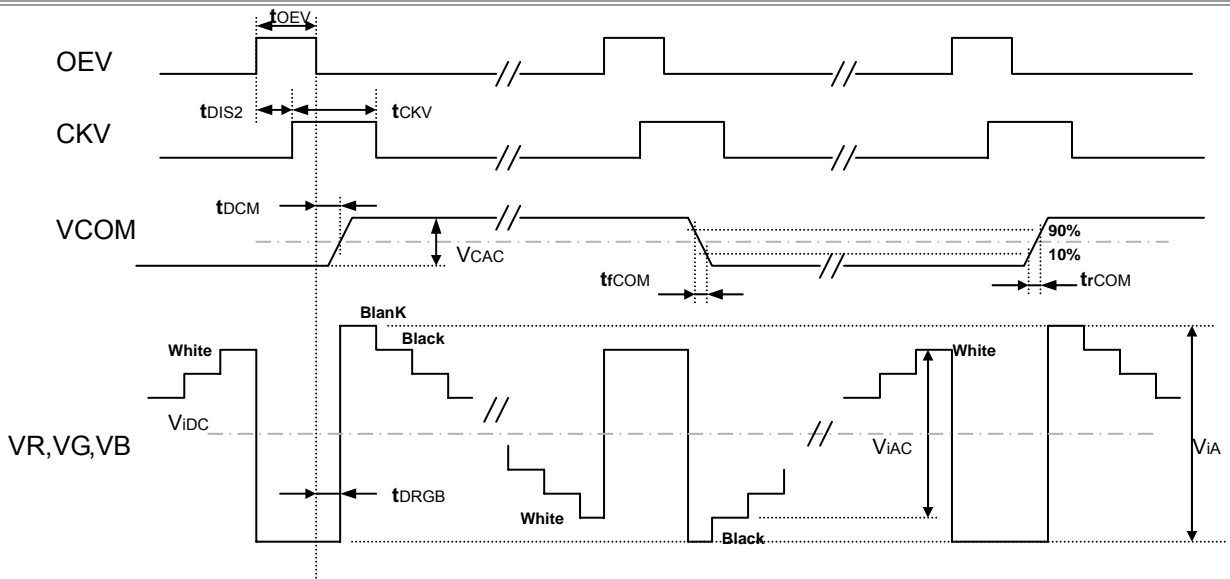

Detail Horizontal timing

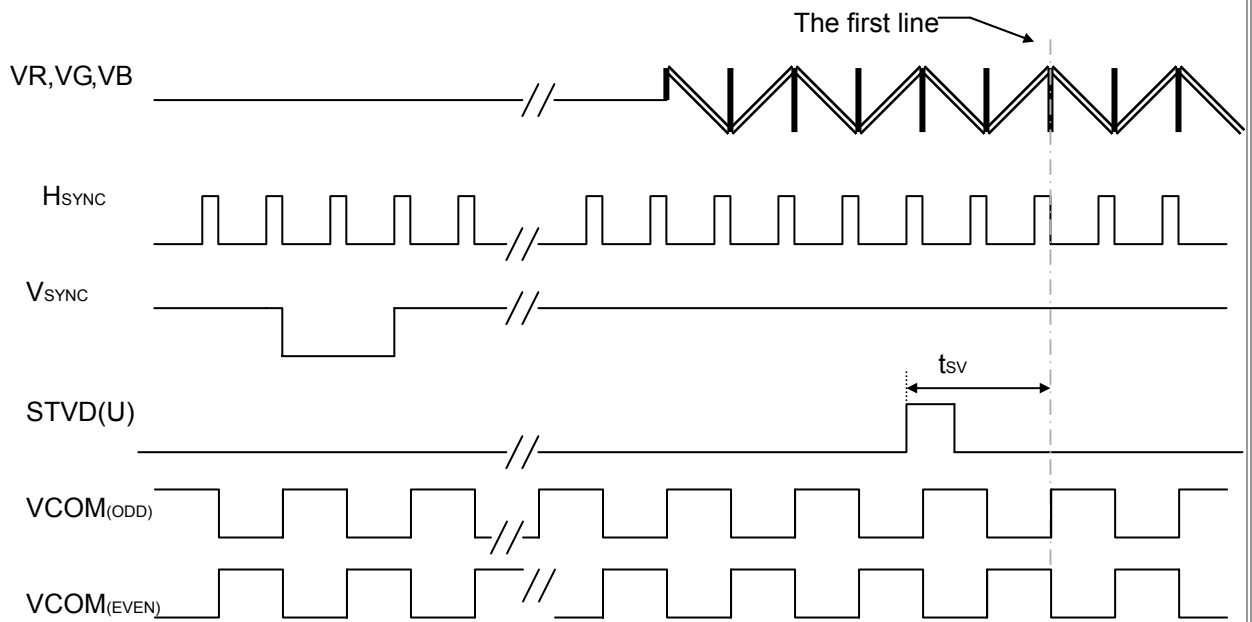

Vertical timing

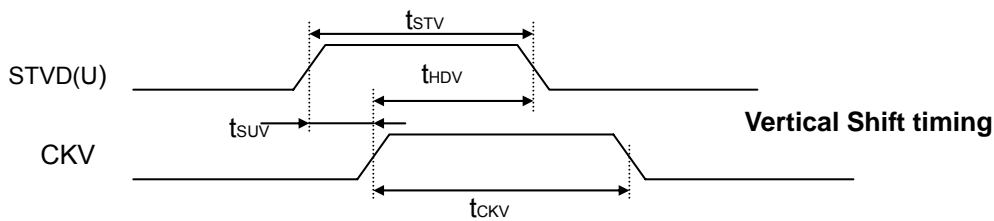

Vertical Shift timing

The information contained in this document is the exclusive property of HannStar Display Corporation. It shall not be disclosed, distributed or reproduced in whole or in part without written permission of HannStar Display Corporation.

Document Title	HSD070I651-F00 CAS for Zenitron	Page No.	17/ 23
Document No.		Revision	1.0

6.5 Power Sequence

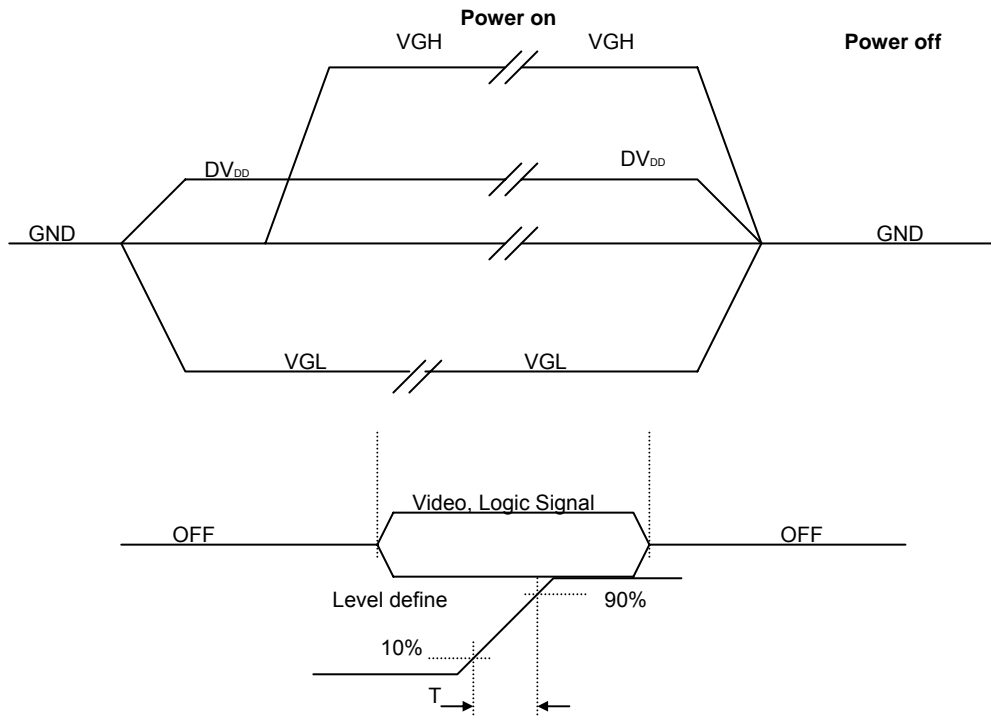

Power Sequence: DV_{DD} -> VGL -> VGH

Note Apply the LED voltage within the LCD operation range. When the back-light turns on before the LCD operation or the LCD turns off before the back-light turns off, the display may momentarily become white.

Document Title	HSD070I651-F00 CAS for Zenitron	Page No.	18/ 23
Document No.		Revision	1.0

7.0 Reliability test items

No.	Item	Conditions	Remark
1	High Temperature Storage	Ta=+80°C, 240hrs	
2	Low Temperature Storage	Ta=-30°C, 240hrs	
3	High Temperature Operation	Ta=+70°C, 240hrs	
4	Low Temperature Operation	Ta=-20°C, 240hrs	
5	High Temperature and High Humidity (operation)	Ta=+60°C, 90%RH, 240hrs	
6	Thermal Cycling Test (non operation)	-30°C(30min) → +80°C(30min), 200cycles	
7	Electrostatic Discharge	±200V,200pF(0Ω) 1 time/each terminal	
8	Vibration	1.Random: 1.04Grms, 10~500Hz, X/Y/Z, 30min/each direction 2.Sweep sine: 1.5G, 5~500Hz, X/Y/Z, 30min/each direction	
9	Shock	100G,6ms, ±X, ±Y, ±Z 3 time for each direction	JIS C7021, A-10 (Condition A)
10	Vibration (with carton)	Random: 1.04Grms, 10~500Hz, X/Y/Z 45min/each direction Fixed: 5Hz, 1.5Grms, X/Y/Z 45min/each direction	
11	Drop (with carton)	Height: 60cm 1 corner, 3 edges, 6 surfaces	JIS Z0202

Note: There are no display function NG issue occurred, All the cosmetic specification is judged before the reliability stress.

Document Title	HSD070I651-F00 CAS for Zenitron	Page No.	19/ 23
Document No.		Revision	1.0

8.0 OUTLINE DIMENSION

Unit : mm

8.1 Outline Dimension

FPC length: 41.29 mm

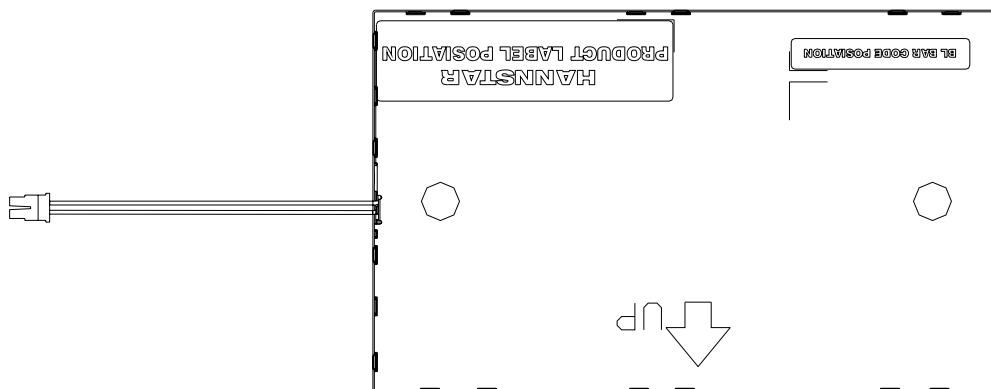
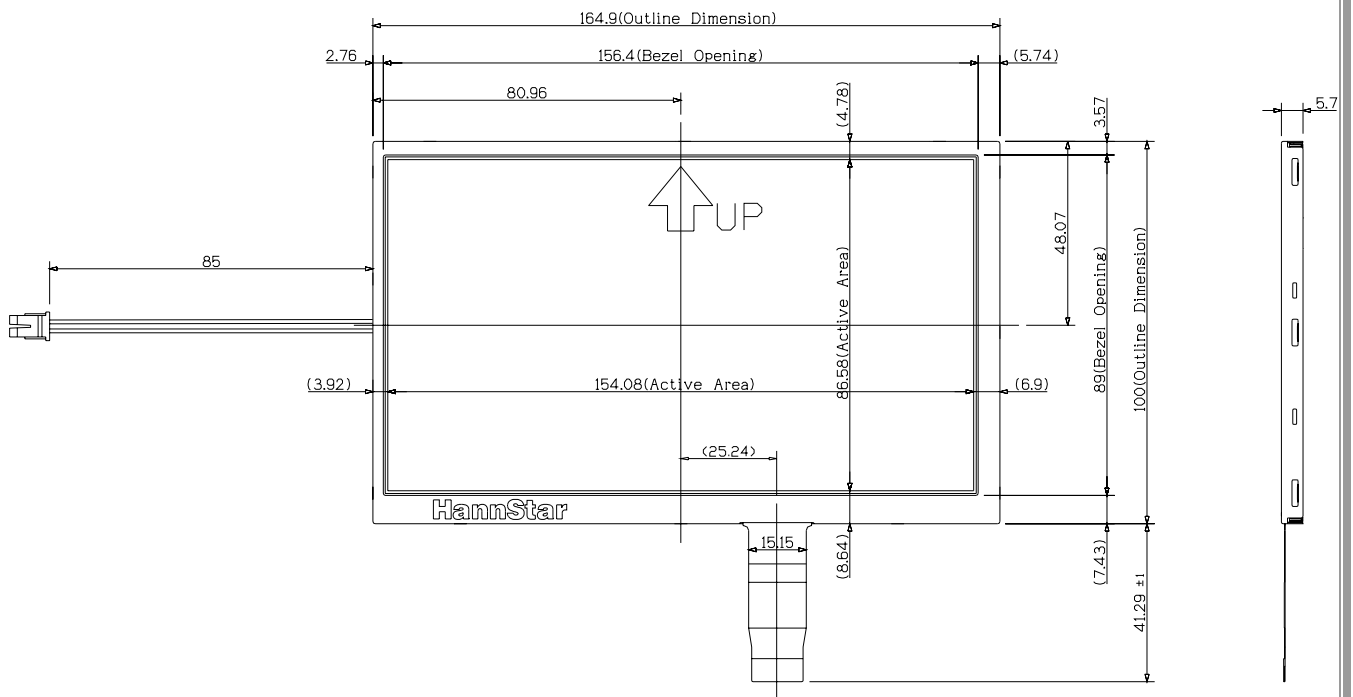

Note : General Tolerance : +/- 0.3mm

The information contained in this document is the exclusive property of HannStar Display Corporation. It shall not be disclosed, distributed or reproduced in whole or in part without written permission of HannStar Display Corporation.

Document Title	HSD070I651-F00 CAS for Zenitron	Page No.	20/ 23
Document No.		Revision	1.0

9.0 LOT MARK

9.1 Lot Mark

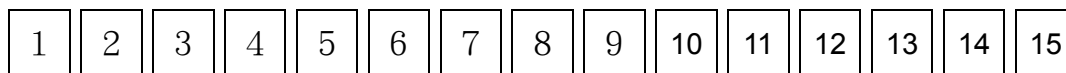

code 1,2,3,4,5,6: HannStar internal flow control code.

code 7: production location.

code 8: production year.

code 9: production month.

code 10,11,12,13,14,15: serial number.

Note (1) Production Year

Year	1999	2000	2001	2002	2003	2004	2005	2006	2007	2008
Mark	9	0	1	2	3	4	5	6	7	8

Note (2) Production Month

Month	Jan.	Feb.	Mar.	Apr.	May.	Jun.	Jul.	Aug.	Sep.	Oct	Nov.	Dec.
Mark	1	2	3	4	5	6	7	8	9	A	B	C

9.2 Location of Lot Mark

- (1) The label is attached to the backside of the LCD module.
- (2) This is subject to change without prior notice.

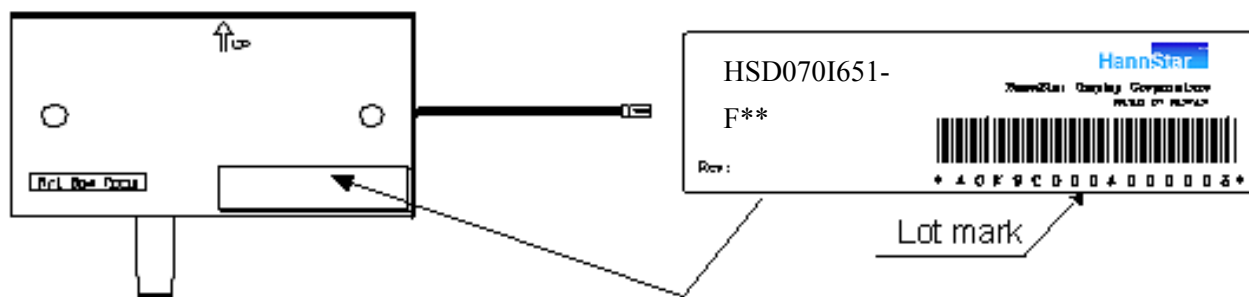

Document Title	HSD070I651-F00 CAS for Zenitron	Page No.	21/ 23
Document No.		Revision	1.0

10.0 PACKAGE SPECIFICATION

10.1 packing form

- (1) Package quantity in one carton: 60 pieces.
- (2) Carton size: 464±3 mm×360±3 mm×370±3 mm.
- (3) For domestic transportation only.

10.2 packing assembly drawings

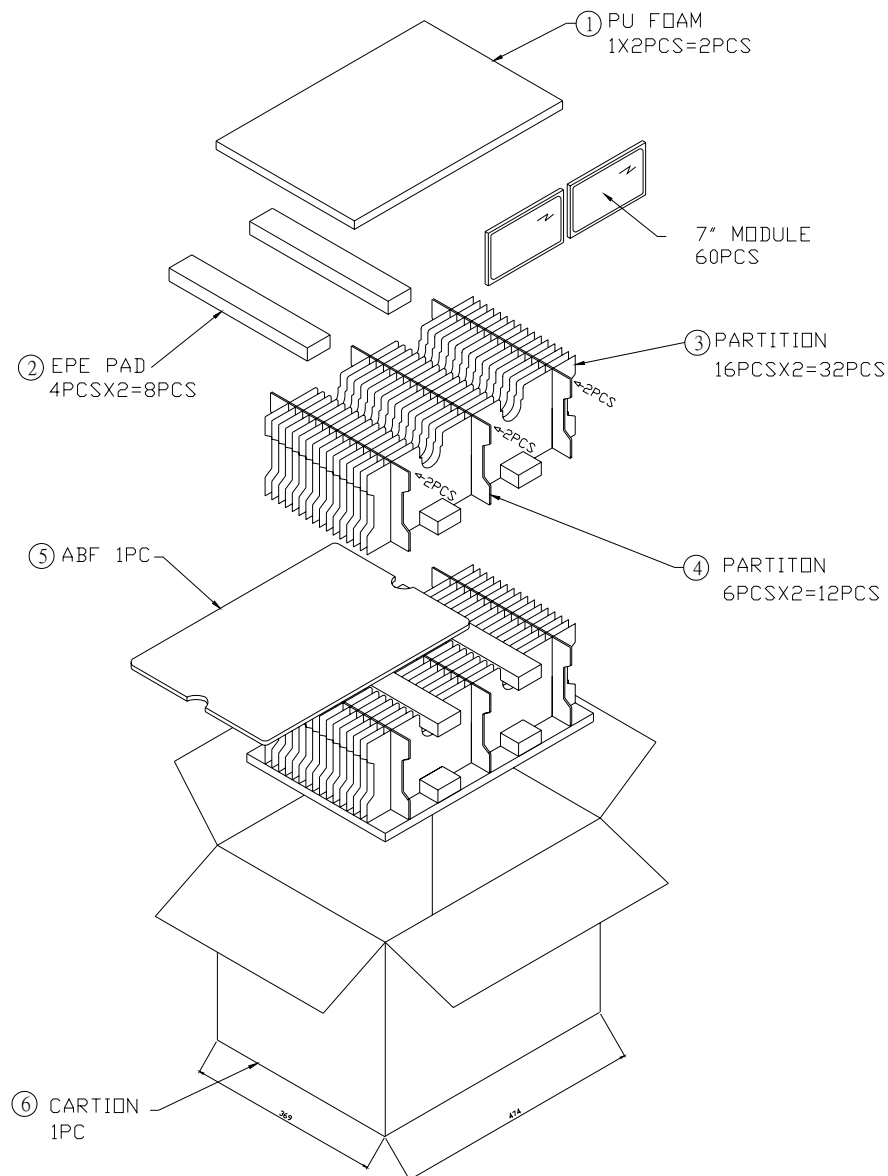

The information contained in this document is the exclusive property of HannStar Display Corporation. It shall not be disclosed, distributed or reproduced in whole or in part without written permission of HannStar Display Corporation.

Document Title	HSD070I651-F00 CAS for Zenitron	Page No.	22/ 23
Document No.		Revision	1.0

11.0 GENERAL PRECAUTION

11.1 Use Restriction

This product is not authorized for use in life supporting systems, aircraft navigation control systems, military systems and any other application where performance failure could be life-threatening or otherwise catastrophic.

11.2 Disassembling or Modification

Do not disassemble or modify the module. It may damage sensitive parts inside LCD module, and may cause scratches or dust on the display. HannStar does not warrant the module, if customers disassemble or modify the module.

11.3 Breakage of LCD Panel

- 11.3.1. If LCD panel is broken and liquid crystal spills out, do not ingest or inhale liquid crystal, and do not contact liquid crystal with skin.
- 11.3.2. If liquid crystal contacts mouth or eyes, rinse out with water immediately.
- 11.3.3. If liquid crystal contacts skin or cloths, wash it off immediately with alcohol and rinse thoroughly with water.
- 11.3.4. Handle carefully with chips of glass that may cause injury, when the glass is broken.

11.4 Electric Shock

- 11.4.1. Disconnect power supply before handling LCD module.
- 11.4.2. Do not pull or fold the LED cable.
- 11.4.3. Do not touch the parts inside LCD modules and the fluorescent LED's connector or cables in order to prevent electric shock.

11.5 Absolute Maximum Ratings and Power Protection Circuit

- 11.5.1. Do not exceed the absolute maximum rating values, such as the supply voltage variation, input voltage variation, variation in parts' parameters, environmental temperature, etc., otherwise LCD module may be damaged.
- 11.5.2. Please do not leave LCD module in the environment of high humidity and high temperature for a long time.
- 11.5.3. It's recommended to employ protection circuit for power supply.

11.6 Operation

- 11.6.1 Do not touch, push or rub the polarizer with anything harder than HB pencil lead.
- 11.6.2 Use fingerstalls of soft gloves in order to keep clean display quality, when persons handle the LCD module for incoming inspection or assembly.
- 11.6.3 When the surface is dusty, please wipe gently with absorbent cotton or other soft material.

Document Title	HSD070I651-F00 CAS for Zenitron	Page No.	23/ 23
Document No.		Revision	1.0

11.6.4 Wipe off saliva or water drops as soon as possible. If saliva or water drops contact with polarizer for a long time, they may causes deformation or color fading.

11.6.5 When cleaning the adhesives, please use absorbent cotton wetted with a little petroleum benzine or other adequate solvent.

11.7 Mechanism

Please mount LCD module by using mouting holes arranged in four corners tightly.

11.8 Static Electricity

11.8.1 Protection film must remove very slowly from the surface of LCD module to prevent from electrostatic occurrence.

11.8.2. Because LCD module use CMOS-IC on circuit board and TFT-LCD panel, it is very weak to electrostatic discharge. Please be careful with electrostatic discharge.

Persons who handle the module should be grounded through adequate methods.

11.9 Strong Light Exposure

The module shall not be exposed under strong light such as direct sunlight. Otherwise, display characteristics may be changed.

11.10 Disposal

When disposing LCD module, obey the local environmental regulations.