



Document Title	HSD121MS11-A Product Information	Page No.	1 / 27
Document No.		Revision	1.0

HannStar Product Information

Model : **HSD121MS11**
-A

Issue Date: 2001-12-06

- Note:
- 1.The information contained herein is preliminary and may be changed without prior notices.
 - 2.Please contact HannStar Display Corp. before designing your product based on this module specification.
 - 3.The information contained herein is presented merely to indicate the characteristics and performance of our products. No responsibility is assumed by HannStar for any intellectual property claims or other problems that may result from application based on the module described herein.



Document Title	HSD121MS11-A Product Information	Page No.	2 / 27
Document No.		Revision	1.0

Record of Revisions

Rev.	Date	Description of change



Document Title	HSD121MS11-A Product Information	Page No.	3 / 27
Document No.		Revision	1.0

Contents

1.0	General descriptions	p.4
2.0	Absolute maximum ratings	p.5
3.0	Optical characteristics	p.7
4.0	Electrical characteristics	p.11
5.0	Block diagram	p.13
6.0	Interface pin connection	p.14
7.0	Interface timing	p.20
8.0	Outline dimension	p.23
9.0	Lot mark	p.25
10.0	General precaution	p.26

Document Title	HSD121MS11-A Product Information	Page No.	4 / 27
Document No.		Revision	1.0

1.0 GENERAL DESCRIPTION

1.1 Introduction

HannStar Display model HSD121MS11-A is a color active matrix thin film transistor (TFT) liquid crystal display(LCD) that uses amorphous silicon TFT as a switching device. This model is composed of a TFT LCD panel, a driving circuit and a back light system. This TFT LCD has a 12.1 inch diagonally measured active display area with SVGA resolution (600 vertical by 800 horizontal pixel array) and can display up to 262,144 colors.

1.2 Features

- 12.1" SVGA for Multimedia & Industrial panel
- LVDS interface system.
- Long lamp life time.
- Replaceable lamp holder.

1.3 Applications

- Multimedia player
- OA equipment
- Display terminals
- Measuring Instrument
- New media equipment

1.4 General information

Item	Specification	Unit
Display area	246.0(H) x 184.5(V)	mm
Number of Pixel	800(H) x 600(V)	pixels
Pixel pitch	0.3075(H) x 0.3075(V)	mm
Pixel arrangement	RGB Vertical stripe	
Display color	262,144	colors
Display mode	Normally white	
Surface treatment	Antiglare, Hard-Coating(3H)	
Weight	825	g
Back-light	Four CCFL	
Input signal	1-ch LVDS	
Optimum viewing direction	6 o'clock	

Document Title	HSD121MS11-A Product Information	Page No.	5 / 27
Document No.		Revision	1.0

1.5 Mechanical Information

Item		Min.	Typ.	Max.	Unit
Module Size	Horizontal(H)	—	276.4	—	Mm
	Vertical(V)	—	209.8	—	Mm
	Depth(D)	—	13.4	—	Mm
Weight (Without inverter)		—	825	—	G

2.0 ABSOLUTE MAXIMUM RATING

2.1 Absolute Rating of Environment

Item	Symbol	Min.	Max.	Unit	Note
Storage temperature	T _{STG}	-20	60	°C	
Operating temperature	T _{OPR}	0	50	°C	
Vibration(non-operating)	V _{nop}	—	1.5	G	(1)
Shock(non-operating)	S _{nop}	—	70	G	(2)
Storage humidity	H _{STG}	10	90	%RH	(3)
Operating humidity	H _{OP}	10	80	%RH	(3)
Low pressure(operating)	H _{LOP}	697	—	hPa	(4)
Low pressure(non-operating)	H _{LNOP}	116	—	hPa	(5)

Note (1)10-500-5Hz,sine wave, 30min/cycle, X/Y/Z each one cycle except for resonant frequency.

(2)11ms/± X,± Y,± Z direction, half-sine wave.

(3)Max wet bulb temp =39°C

(4)2 hours. (10000 feet)

(5)24 hours. (50000 feet)

2.2 Electrical Absolute Rating

2.2.1 TFT LCD Module

Item	Symbol	Min.	Max.	Unit	Note
Power supply voltage	V _{DD}	-0.3	4.0	V	(1)
Logic input voltage	V _{IN}	-0.3	VDD+0.3	V	(1)



Document Title	HSD121MS11-A Product Information	Page No.	6 / 27
Document No.		Revision	1.0

2.2.2 Back-Light Unit

Item	Symbol	Min.	Max.	Unit	Note
Lamp voltage	V_L	0	2000	V_{rms}	(1)
Lamp current	I_L	2.0	7.0	mA	(1)
Lamp frequency	f_L	50	80	kHz	(1)

Note (1) Permanent damage may occur to the LCD module if beyond this specification. Functional operation should be restricted to the conditions described under normally operating conditions.

Document Title	HSD121MS11-A Product Information	Page No.	7 / 27
Document No.		Revision	1.0

3.0 OPTICAL CHARACTERISTICS

3.1 Optical specification

Item		Symbol	Condition	Min.	Typ.	Max.	Unit	Note
Contrast		CR	$\theta=0$ $\Phi=0$ Normal viewing angle	—	350	—		(1)(2)
Response time	Rising	T_R		—	Tr+Tf=25	—	msec	(1)(3)
	Falling	T_F		—				
luminance of white(center)		Y_L		—	400	—	cd/m ²	(1)(4)(5) ($I_L=6.0mA$)
Color chromaticity (CIE1931)	Red	R_x		TBD	TBD	TBD		(1)(4)
		R_y		TBD	TBD	TBD		
	Green	G_x		TBD	TBD	TBD		
		G_y		TBD	TBD	TBD		
	Blue	B_x		TBD	TBD	TBD		
		B_y		TBD	TBD	TBD		
	White	W_x	—	0.310	—			
		W_y	—	0.33	—			
Viewing angle	Hor.	θ_L	CR>10	—	60	—		
		θ_R		—	60	—		
	Ver.	θ_U		—	40	—		
		θ_D		—	60	—		
Brightness uniformity		B_{UNI}		70	—	—	%	(6)

Document Title	HSD121MS11-A Product Information	Page No.	8 / 27
Document No.		Revision	1.0

3.2 Measuring Condition

- Measuring surrounding : dark room
- Lamp current I_L :6.0mA, lamp freq. $F_L= 50\text{KHz}$
- $V_{DD}=3.3\text{V}\pm 0.3\text{V}$
- Inverter Model: Emax-PLM143
- Surrounding temperature : 25°C
- 50min. warm-up time

3.3 Measuring Equipment

- LCD-7000 of Otsuka Electrics Corp., which utilized MCPD-7000 for Chromaticity and BM-5A for other optical characteristics.
- Measuring spot size : 10~12mm

Note (1) Definition of Viewing Angle :

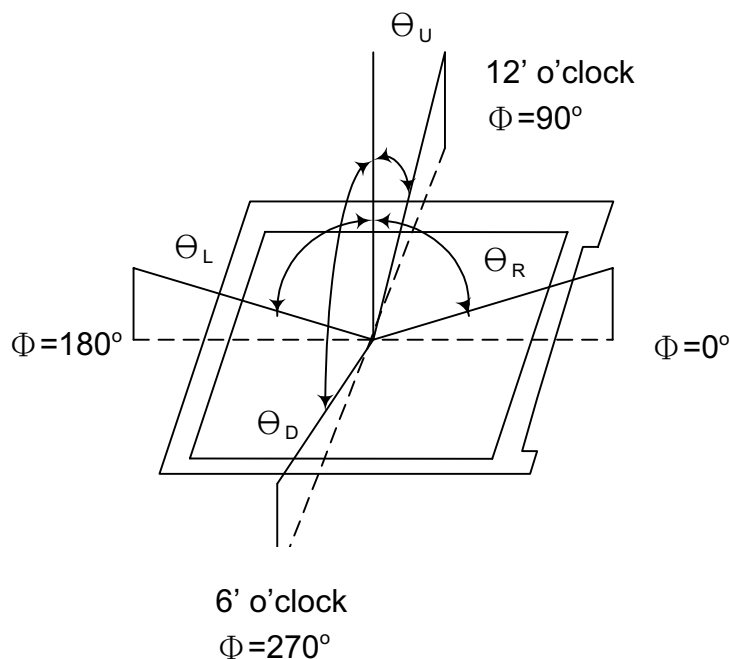

Note (2) Definition of Contrast Ratio(CR) :
measured at the center point of panel

$$CR = \frac{\text{Luminance with all pixels white}}{\text{Luminance with all pixels black}}$$

Document Title	HSD121MS11-A Product Information	Page No.	9 / 27
Document No.		Revision	1.0

Note (3) Definition of Response Time : Sum of T_R and T_F

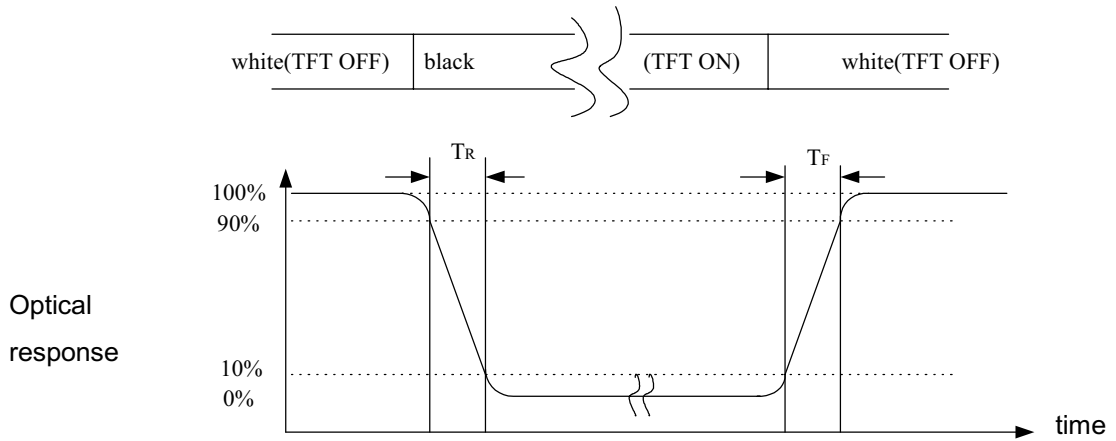

Note (4) Optical Characteristic Measurement Setup

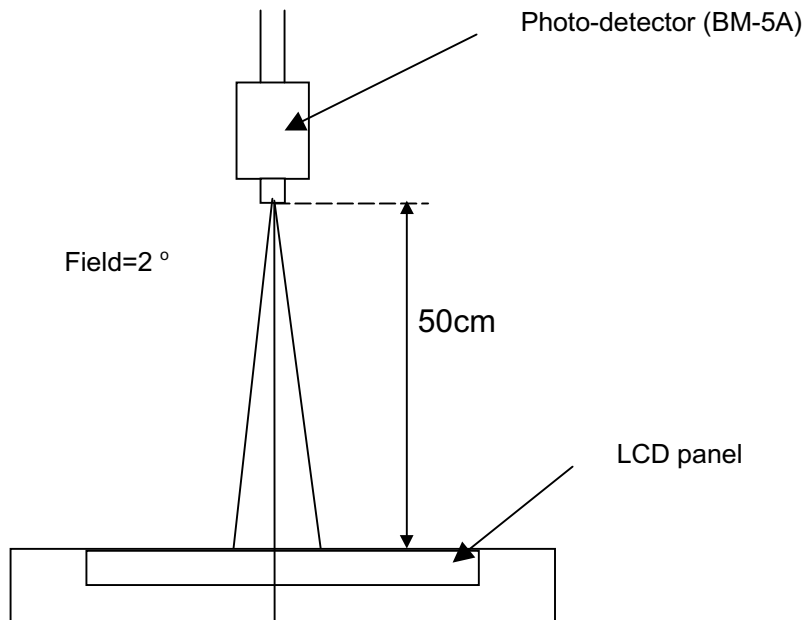

Document Title	HSD121MS11-A Product Information	Page No.	10 / 27
Document No.		Revision	1.0

Note (5) Definition of Luminance of White: measured the luminance of white at Y1

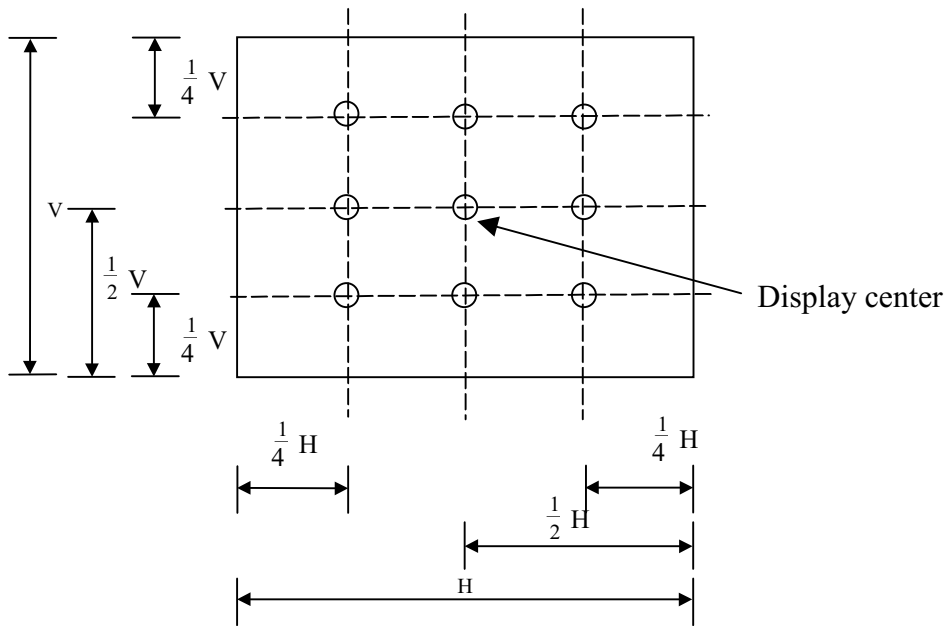

Note (6) Definition of Brightness Uniformity

$$\text{Luminance uniformity} = \frac{(\text{Min Luminance of 9 points})}{(\text{Max Luminance of 9 points})} \times 100\%$$

Document Title	HSD121MS11-A Product Information	Page No.	11 / 27
Document No.		Revision	1.0

4.0 ELECTRICAL CHARACTERISTICS

4.1 TFT LCD Module

Item	Symbol	Min.	Typ.	Max.	Unit	Note	
	V_{DD}	3.0	3.3	3.6	V		
Differential input threshold voltage	High	V_{IH}	—	—	100	mV	$V_{CM}=1.2V$
	Low	V_{IL}	-100	—	—	mV	
Current of power supply	Mosaic	I_{DD}	—	TBD	—	mA	(1)
Vsync frequency	f_V	—	60	—	Hz	(2)	
Hsync frequency	f_H	—	37.9	—	kHz		
Main frequency	f_{DCLK}	38	40	42	MHz		

Note (1) Mosaic : Dot checker image

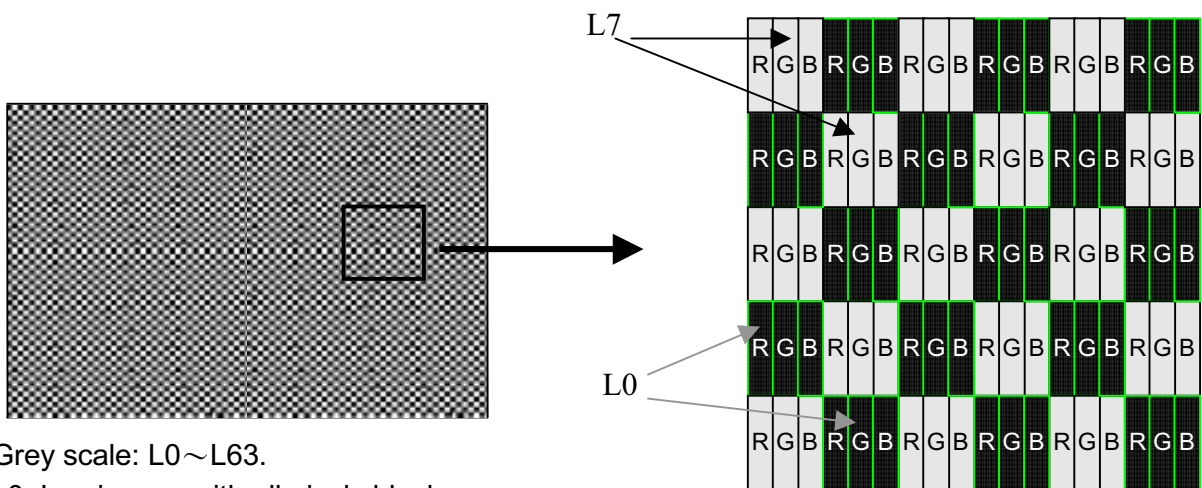

Grey scale: L0~L63.

L0: Luminance with all pixels black.

L63: Luminance with all pixels white.

Note (2) When f_v is too low, a flicker may be occurred on the display.

Document Title	HSD121MS11-A Product Information	Page No.	12 / 27
Document No.		Revision	1.0

4.2 Back-Light Unit

The back-light system is 4 CCFL(Cold Cathode Fluorescent Lamp).

The characteristics of the lamp is shown in the following tables.

INVERTER: Emax-PLM143.(1)

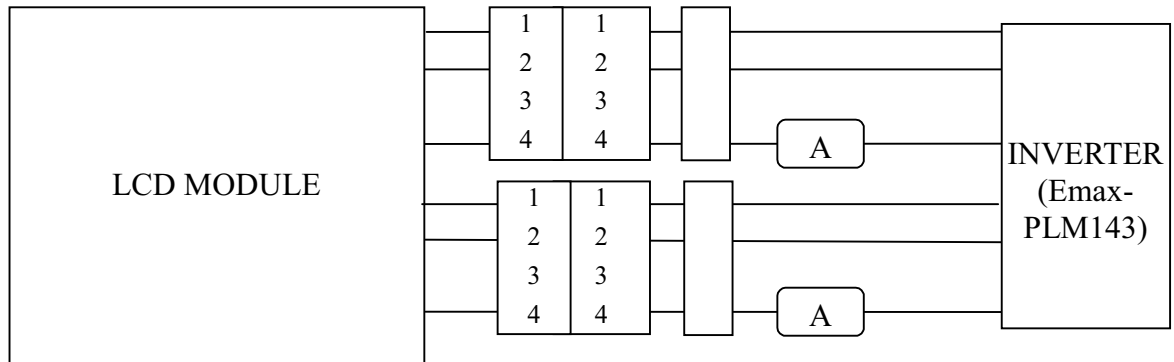

Item	Symbol	Min.	Typ.	Max.	Unit	Note
Lamp current	IL	--	6.0	--	mA(rms)	(1)
Lamp voltage	VL	--	530	--	V(rms)	$I_L=6.0mA$
Frequency	fL		50		KHz	(2)
Lamp Operating life time	Hr	50,000	--	--	Hour	(3)
Startup voltage	Vs	--	--	1224	V(rms)	at 25°C
				1314		at 0°C

Note (1) Lamp current is measured with current meter for high frequency as shown below. Specified valued are for a lamp.

Note (2) Lamp frequency may produce interference with horizontal synchronous frequency and this may cause line flow on the display. Therefore lamp frequency shall be detached from the horizontal synchronous frequency and its harmonics as far as possible in order to avoid interference.

Note (3) Lamp operating Life time (Hr) can be defined as the time in which it continues to operate under the condition : $T_a=25\sim35^\circ C$, $I_L=6.0mA$ (typ) until one of the following event occurs :

1. When the brightness becomes 50%
2. At 0°C, the starting voltage of lamp must exceed the Max startup voltage.

Document Title	HSD121MS11-A Product Information	Page No.	13 / 27
Document No.		Revision	1.0

5.0 BLOCK DIAGRAM
5.1 TFT LCD Module

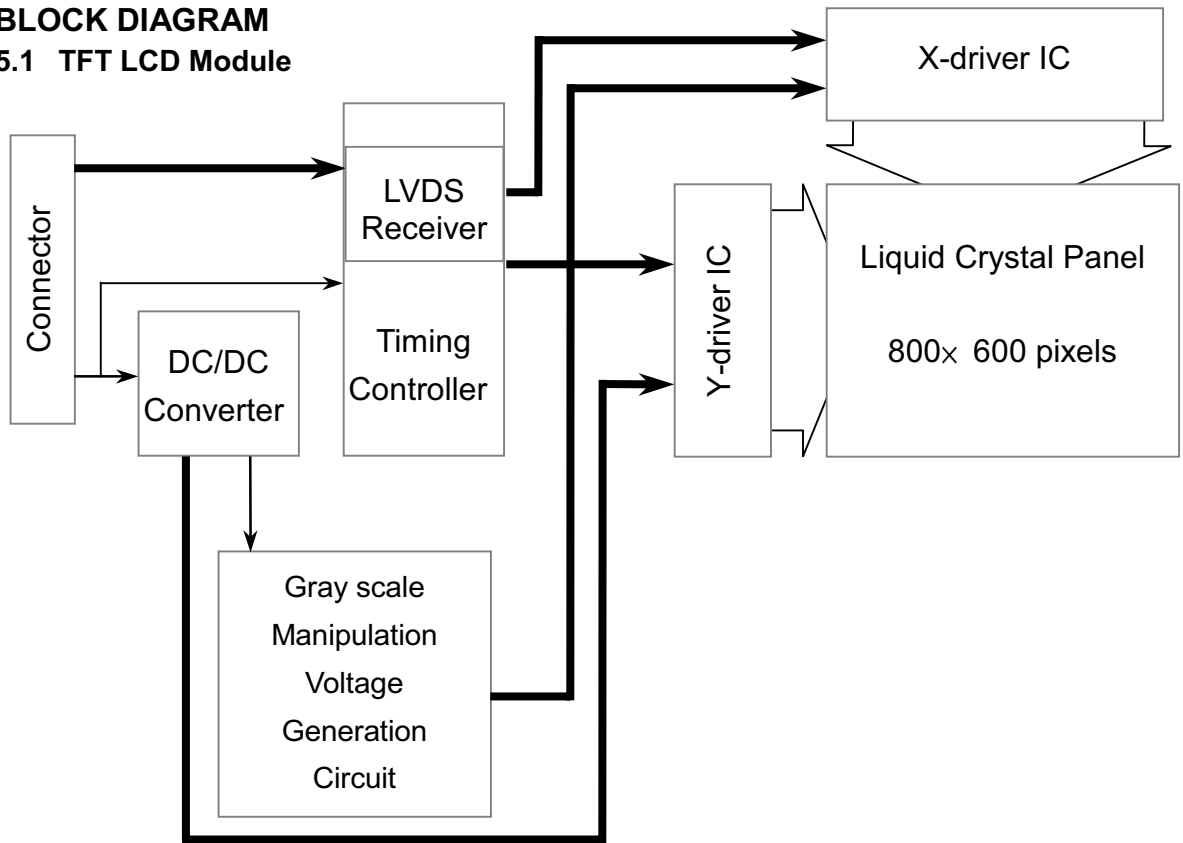

5.2 Back Light Unit

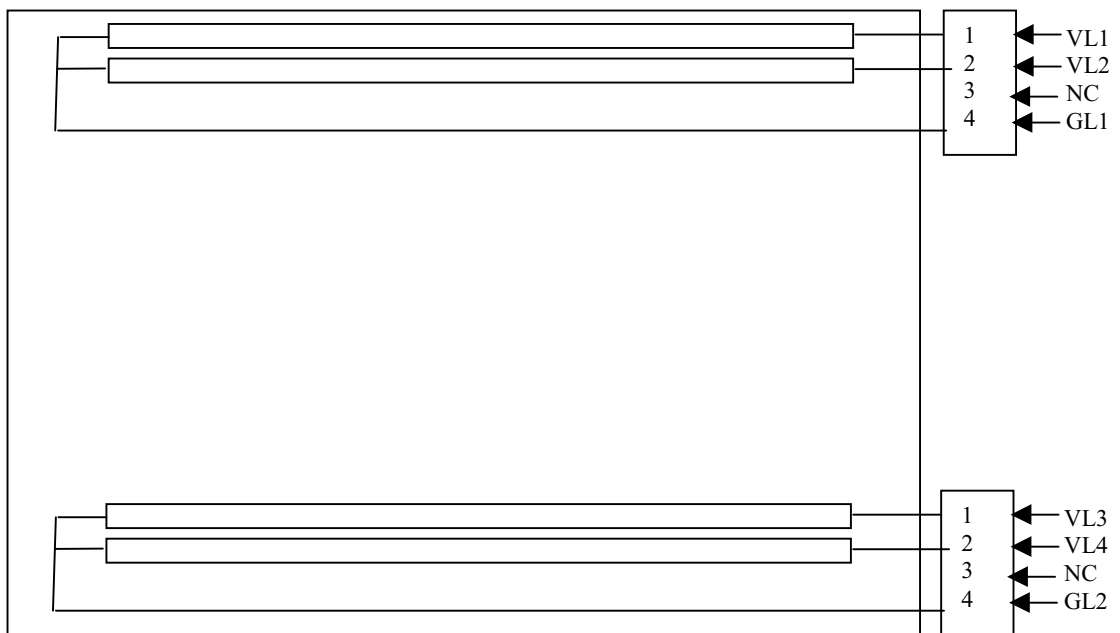

Document Title	HSD121MS11-A Product Information	Page No.	14 / 27
Document No.		Revision	1.0

6.0 INTERFACE PIN CONNECTION

6.1 TFT LCD Module

Connector : JAE FI-SEB-20P-HF 10

Matching Socket : FI-SE20MR or FI-SE20M

Pin No.	Symbol	Function	Polarity	Remark
1	VDD	Power Supply : +3.3V	—	
2	VDD	Power Supply : +3.3V	—	
3	GND	Ground	—	
4	GND	Ground	—	
5	IN0-	Transmission Data of Pixels 0	Negative	
6	IN0+	Transmission Data of Pixels 0	Positive	
7	GND	Ground		
8	IN1-	Transmission Data of Pixels 1	Negative	
9	IN1+	Transmission Data of Pixels 1	Positive	
10	GND	Ground		
11	IN2-	Transmission Data of Pixels 2	Negative	
12	IN2+	Transmission Data of Pixels 2	Positive	
13	GND	Ground	—	
14	CLK-	Sampling Clock	Negative	
15	CLK+	Sampling Clock	Positive	
16	GND	Ground		
17	NC			
18	NC			
19	GND	Ground		
20	GND	Ground		

6.2 Back-Light Unit

CCFL Power Source (BHR-04VS-1/Japan Solderless Terminal MFG Co., LTD)

Terminal no.	Symbol	Function
1	VL1	CCFL power supply (high voltage)
2	VL2	CCFL power supply (high voltage)
3	NC ¹⁾	
4	GL1	CCFL power supply (low voltage)



Document Title	HSD121MS11-A Product Information	Page No.	15 / 27
Document No.		Revision	1.0

CCFL Power Source (BHR-04VS-1/Japan Solderless Terminal MFG Co., LTD)

Terminal no.	Symbol	Function
1	VL3	CCFL power supply (high voltage)
2	VL4	CCFL power supply (high voltage)
3	NC ¹⁾	
4	GL2	CCFL power supply (low voltage)

Note 1) Please connects NC pin to nothing. Don't connect it to ground nor to other signal Input. (NC pin should be open.)



Document Title	HSD121MS11-A Product Information	Page No.	16 / 27
Document No.		Revision	1.0

6.3 Relationship Between Displayed Color and Input

	Display	MSB						LSB						Gray scale level						
		R5	R4	R3	R2	R1	R0	G5	G4	G3	G2	G1	G0		B5	B4	B3	B2	B1	B0
Basic color	Black	L	L	L	L	L	L	L	L	L	L	L	L	L	L	L	L	L	L	-
	Blue	L	L	L	L	L	L	L	L	L	L	L	L	H	H	H	H	H	H	-
	Green	L	L	L	L	L	L	H	H	H	H	H	H	L	L	L	L	L	L	-
	Light Blue	L	L	L	L	L	L	H	H	H	H	H	H	H	H	H	H	H	H	-
	Red	H	H	H	H	H	H	L	L	L	L	L	L	L	L	L	L	L	L	-
	Purple	H	H	H	H	H	H	L	L	L	L	L	L	H	H	H	H	H	H	-
	Yellow	H	H	H	H	H	H	H	H	H	H	H	H	L	L	L	L	L	L	-
	White	H	H	H	H	H	H	H	H	H	H	H	H	H	H	H	H	H	H	-
Gray scale of Red	Black	L	L	L	L	L	L	L	L	L	L	L	L	L	L	L	L	L	L	L0
	Dark ↑ ↓ Light	L	L	L	L	L	H	L	L	L	L	L	L	L	L	L	L	L	L	L1
		L	L	L	L	H	L	L	L	L	L	L	L	L	L	L	L	L	L	L2
		⋮	⋮	⋮	⋮	⋮	⋮	⋮	⋮	⋮	⋮	⋮	⋮	⋮	⋮	⋮	⋮	⋮	⋮	⋮
		H	H	H	H	L	H	L	L	L	L	L	L	L	L	L	L	L	L	L61
		H	H	H	H	H	L	L	L	L	L	L	L	L	L	L	L	L	L	L62
	Red	H	H	H	H	H	H	L	L	L	L	L	L	L	L	L	L	L	L	Red L63
	Gray scale of Green	Black	L	L	L	L	L	L	L	L	L	L	L	L	L	L	L	L	L	L
Dark ↑ ↓ Light		L	L	L	L	L	L	L	L	L	L	L	H	L	L	L	L	L	L	L1
		L	L	L	L	L	L	L	L	L	L	L	H	L	L	L	L	L	L	L2
		⋮	⋮	⋮	⋮	⋮	⋮	⋮	⋮	⋮	⋮	⋮	⋮	⋮	⋮	⋮	⋮	⋮	⋮	⋮
		L	L	L	L	L	L	H	H	H	H	L	H	L	L	L	L	L	L	L61
		L	L	L	L	L	L	H	H	H	H	H	L	L	L	L	L	L	L	L62
Green		L	L	L	L	L	L	H	H	H	H	H	H	L	L	L	L	L	L	Green L63
Gray scale of Blue		Black	L	L	L	L	L	L	L	L	L	L	L	L	L	L	L	L	L	L
	Dark ↑ ↓ Light	L	L	L	L	L	L	L	L	L	L	L	L	L	L	L	L	L	H	L1
		L	L	L	L	L	L	L	L	L	L	L	L	L	L	L	L	H	L	L2
		⋮	⋮	⋮	⋮	⋮	⋮	⋮	⋮	⋮	⋮	⋮	⋮	⋮	⋮	⋮	⋮	⋮	⋮	⋮
		L	L	L	L	L	L	L	L	L	L	L	L	H	H	H	H	L	H	L61
		L	L	L	L	L	L	L	L	L	L	L	L	H	H	H	H	H	L	L62
	Blue	L	L	L	L	L	L	L	L	L	L	L	L	H	H	H	H	H	H	Blue L63
	Gray scale of White & Black	Black	L	L	L	L	L	L	L	L	L	L	L	L	L	L	L	L	L	L
Dark ↑ ↓ Light		L	L	L	L	L	H	L	L	L	L	L	H	L	L	L	L	L	H	L1
		L	L	L	L	H	L	L	L	L	L	H	L	L	L	L	L	H	L	L2
		⋮	⋮	⋮	⋮	⋮	⋮	⋮	⋮	⋮	⋮	⋮	⋮	⋮	⋮	⋮	⋮	⋮	⋮	⋮
		H	H	H	H	L	H	H	H	H	H	L	H	H	H	H	H	L	H	L61
		H	H	H	H	H	L	H	H	H	H	H	L	H	H	H	H	H	L	L62
White		H	H	H	H	H	H	H	H	H	H	H	H	H	H	H	H	H	H	White L63

Document Title	HSD121MS11-A Product Information	Page No.	17 / 27
Document No.		Revision	1.0

6.4 Pixel Format

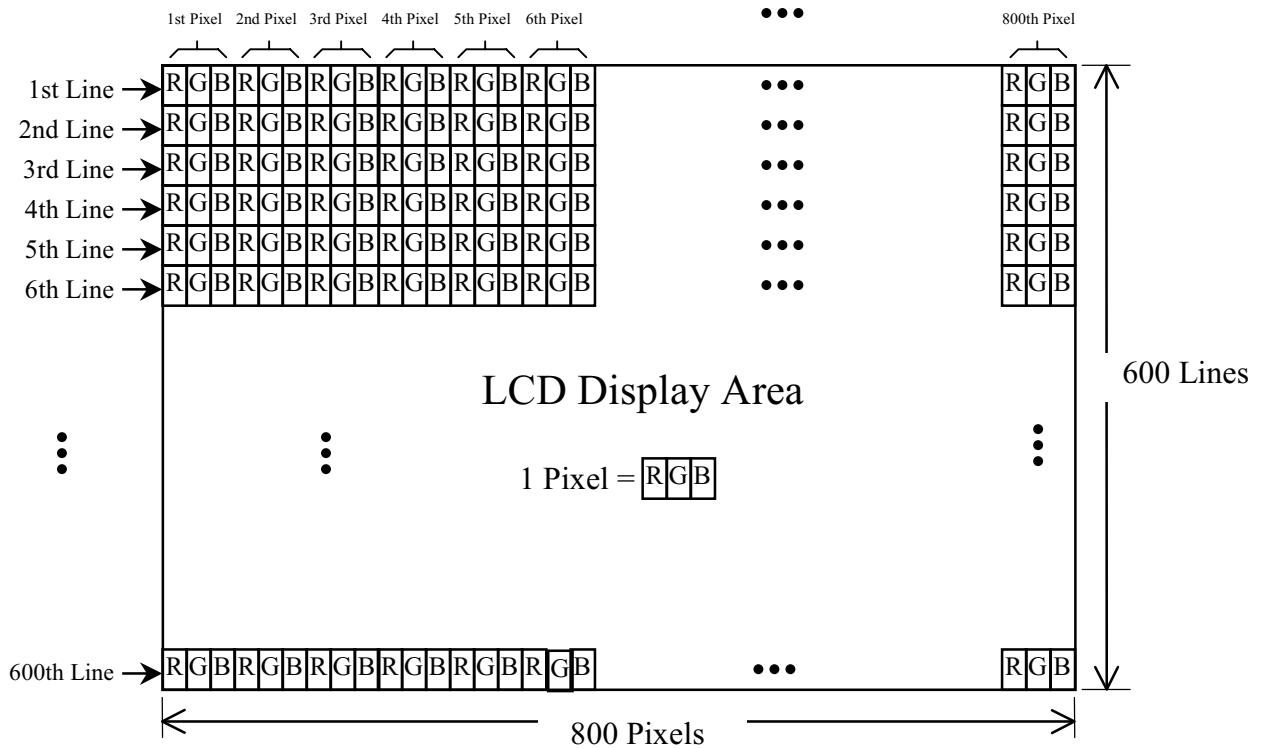

Document Title	HSD121MS11-A Product Information	Page No.	18 / 27
Document No.		Revision	1.0

6.5 Recommended Transmitter to HSD121MS11-A Interface Assignment

Case1: 6bit Transmitter

DS90CF363 or equivalent				HSD121MS11-A interface(CN1)		
Input terminal no.		Input signal (Graphics controller output signal)		Output signal		
Symbol	Terminal	Symbol	Function	Symbol	Terminal	Symbol
TIN0	44	R0	RED Pixels Display Data (LSB)	TOUT0- TOUT0+	No. 5 No. 6	IN0- IN0+
TIN1	45	R1	RED Pixels Display Data			
TIN2	47	R2	RED Pixels Display Data			
TIN3	48	R3	RED Pixels Display Data			
TIN4	1	R4	RED Pixels Display Data			
TIN5	3	R5	RED Pixels Display Data (MSB)			
TIN6	4	G0	RED Pixels Display Data (LSB)	TOUT1- TOUT1+	No. 8 No. 9	IN1- IN1+
TIN7	6	G1	GREEN Pixels Display Data			
TIN8	7	G2	GREEN Pixels Display Data			
TIN9	9	G3	GREEN Pixels Display Data			
TIN10	10	G4	GREEN Pixels Display Data			
TIN11	12	G5	GREEN Pixels Display Data (MSB)			
TIN12	13	B0	BLUE Pixels Display Data (LSB)	TOUT2- TOUT2+	No. 11 No. 12	IN2- IN2+
TIN13	15	B1	BLUE Pixels Display Data			
TIN14	16	B2	BLUE Pixels Display Data			
TIN15	18	B3	BLUE Pixels Display Data			
TIN16	19	B4	BLUE Pixels Display Data			
TIN17	20	B5	BLUE Pixels Display Data (MSB)			
TIN18	22	NC	Non Connection (open)	TOUT2+		
TIN19	23	NC	Non Connection (open)			
TIN20	25	ENAB	Compound Synchronization Signal			
CLK IN	26	NCLK	Data Sampling Clock	TCLK OUT- TCLK OUT+	No. 14 No. 15	CLK IN- CLK IN+

Note : Please connect NC pin to nothing. Don't connect it to ground nor to other signal input.

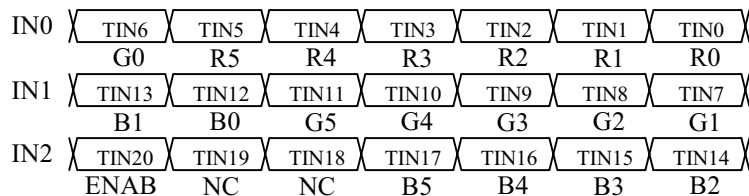

Document Title	HSD121MS11-A Product Information	Page No.	19 / 27
Document No.		Revision	1.0

Case2 : 8bit Transmitter

DS90CF383 or equivalent						
Input terminal no.		Input signal (Graphics control output signal)		Output signal	To HSD121MS11-A interface(CN1)	
Symbol	Terminal	Symbol	Function	Symbol	Terminal	Symbol
TIN0	51	R0	RED Pixels Display Data (LSB)	TOUT0- TOUT0+	No. 5 No. 6	IN0- IN0+
TIN1	52	R1	RED Pixels Display Data			
TIN2	54	R2	RED Pixels Display Data			
TIN3	55	R3	RED Pixels Display Data			
TIN4	56	R4	RED Pixels Display Data			
TIN6	3	R5	RED Pixels Display Data (MSB)	TOUT1- TOUT1+	NO.8 NO.9	IN1- IN1+
TIN7	4	G0	GREEN Pixels Display Data (LSB)			
TIN8	6	G1	GREEN Pixels Display Data			
TIN9	7	G2	GREEN Pixels Display Data			
TIN12	11	G3	GREEN Pixels Display Data			
TIN13	12	G4	GREEN Pixels Display Data	TOUT2- TOUT2+	NO.11 NO.12	IN2- IN2+
TIN14	14	G5	GREEN Pixels Display Data (MSB)			
TIN15	15	B0	BLUE Pixels Display Data (LSB)			
TIN18	19	B1	BLUE Pixels Display Data			
TIN19	20	B2	BLUE Pixels Display Data			
TIN20	22	B3	BLUE Pixels Display Data	TOUT3- TOUT3+	NA	NA
TIN21	23	B4	BLUE Pixels Display Data			
TIN22	24	B5	BLUE Pixels Display Data (MSB)			
TIN24	27	NC	Non Connection (open)			
TIN25	28	NC	Non Connection (open)			
TIN26	30	ENAB	Compound Synchronization Signal	TCLK OUT- TCLK OUT+	NO. 14 NO. 15	CLK IN- CLK IN+
TIN27	50	NC	Non Connection (open)			
TIN5	2	NC	Non Connection (open)			
TIN10	8	NC	Non Connection (open)			
TIN11	10	NC	Non Connection (open)			
TIN16	16	NC	Non Connection (open)			
TIN17	18	NC	Non Connection (open)			
TIN23	25	NC	Non Connection (open)			
CLK IN	31	NCLK	DATA SAMPLING CLOCK			

Note : Please connect NC pin to nothing. Don't connect it to ground nor to other signal input.

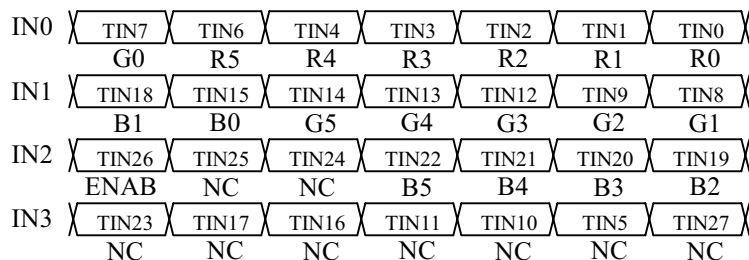

Document Title	HSD121MS11-A Product Information	Page No.	20 / 27
Document No.		Revision	1.0

7.0 INTERFACE TIMING ¹⁾²⁾³⁾⁴⁾⁵⁾⁶⁾

7.1 Timing Parameters (DE mode)

Item	Symbol	Min.	Typ.	Max.	Unit	Remarks
Frame period	t1	627×t3 —	628×t3 16.58	664×t3 —	— ms	1) 5)
Vertical display term	t2	600×t3 —	600×t3 15.84	600×t3 —	— ms	1)
One line Scanning time	t3	1020×t5 —	1056×t5 26.4	1100×t5 —	— μs	1) 5)
Horizontal display term	t4	800×t5 —	800×t5 20.0	800×t5 —	— μs	1)
Clock period	t5	21.0	25.0	—	ns	5)

Note 1) Refer to TIMING CHART at page19, 20 and LVDS specification (DS90CF364MTD) by National Semiconductor Corporation.

Note 2) When ENAB is fixed to “H” level or “L” level after NCLK is supplied, the panel displays black with some flicker.

Note 3) If NCLK is fixed to “H” level or “L” level, for certain period while ENAB is supplied, the panel may be damaged.

Note 4) Do not make t1 and t3’s fluctuate. If t1 or t3 is fluctuating, the panel displays black.

Note 5) Please adjust LCD operating signal timing and FL driving frequency, to optimize the display quality. There is a possibility that flicker is observed by the interference of LCD operating signal timing and FL driving condition (especially driving frequency).

Note 6) All input condition (level & timing) refers to SII211 specification by Silicon Image Inc.

Document Title	HSD121MS11-A Product Information	Page No.	21 / 27
Document No.		Revision	1.0

7.2 Timing Diagram of Interface Signal (DE mode)

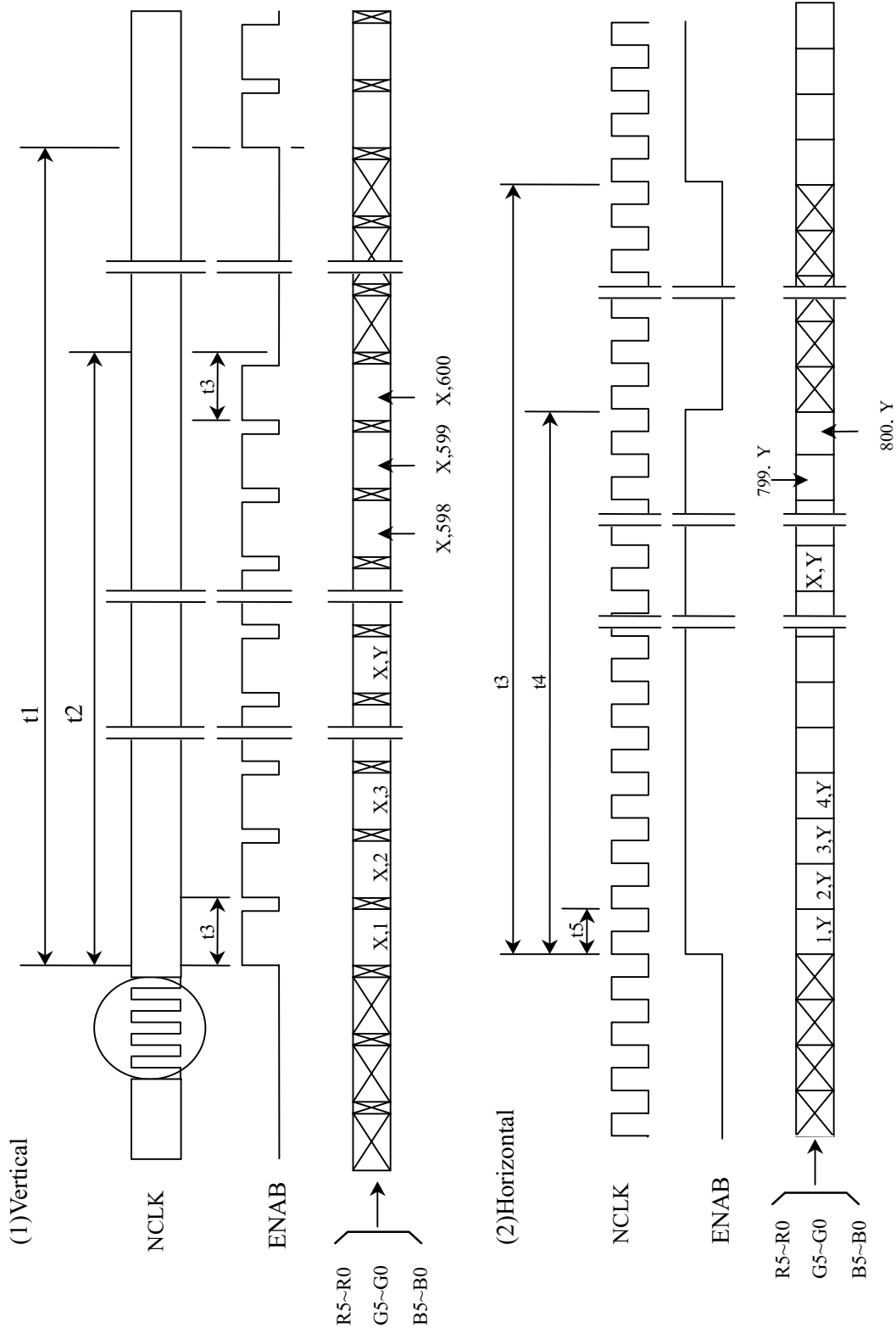

Document Title	HSD121MS11-A Product Information	Page No.	22 / 27
Document No.		Revision	1.0

7.3 Power ON/OFF Sequence

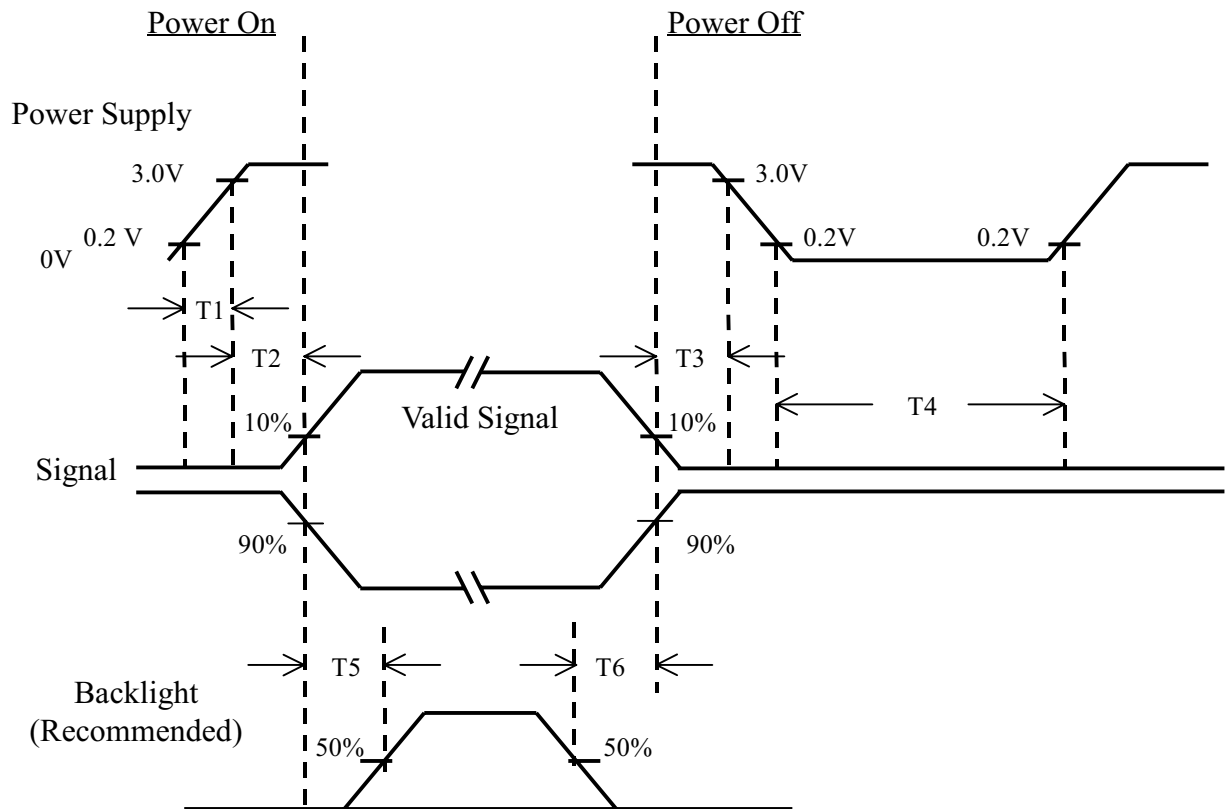

Power ON/OFF Sequence

Item	Min.	Typ.	Max.	Unit	Remark
T1	0	—	10	msec	
T2	0	—	55	msec	
T3	0	—	40	msec	
T4	500	—	—	msec	
T5	200	—	—	msec	
T6	200	—	—	msec	

- (1) The supply voltage of the external system for the module input should be the same as the definition of V_{DD} .
- (2) Apply the lamp voltage within the LCD operation range. When the back-light turns on before the LCD operation or the LCD turns off before the back-light turns off, the display may momentarily become white.
- (3) In case of $V_{DD} = \text{off level}$, please keep the level of input signal on the low or keep a high impedance.
- (4) T4 should be measured after the module has been fully discharged between power off and on period.
- (5) Interface signal shall not be kept at high impedance when the power is on.

Document Title	HSD121MS11-A Product Information	Page No.	23 / 27
Document No.		Revision	1.0

8.0 OUTLINE DIMENSION

(1) Front view outline dimension

Unit: mm

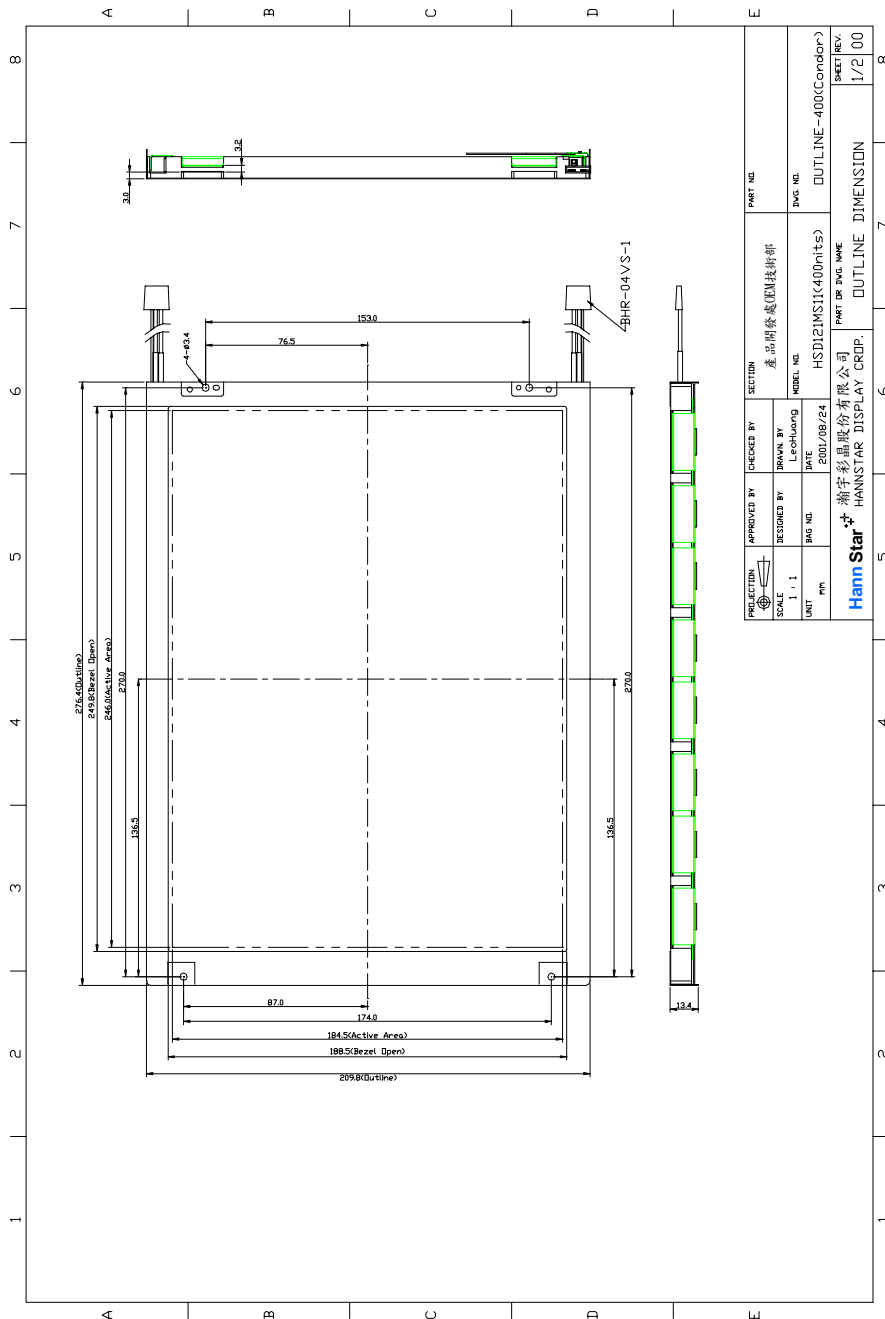

Document Title	HSD121MS11-A Product Information	Page No.	24 / 27
Document No.		Revision	1.0

(2) Back view outline dimension

Unit: mm

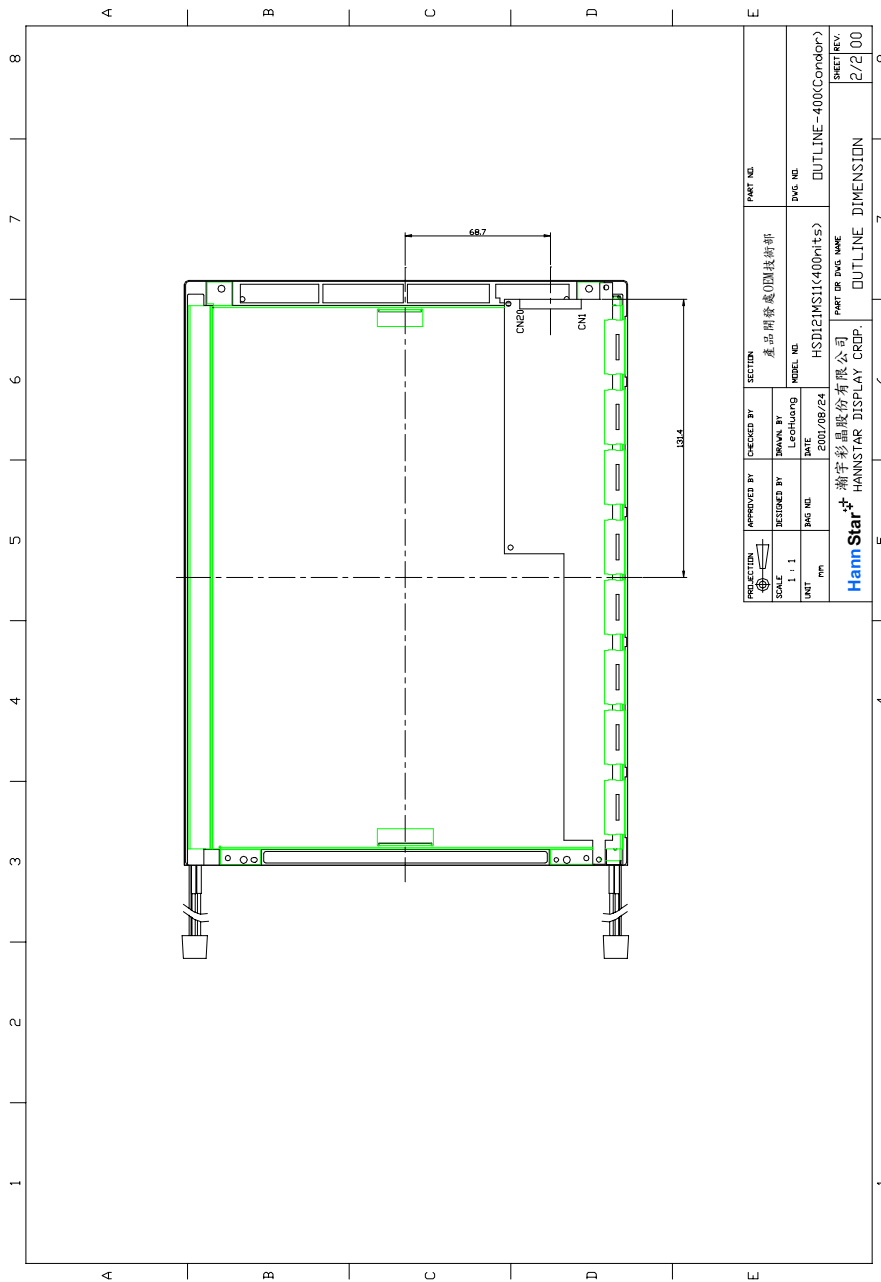

Document Title	HSD121MS11-A Product Information	Page No.	25 / 27
Document No.		Revision	1.0

9.0 LOT MARK

9.1 Lot Mark

1	2	3	4	5	6	7	8	9	10	11	12	13	14	15
---	---	---	---	---	---	---	---	---	----	----	----	----	----	----

code 1,2,3,4,5,6: HannStar internal flow control code.

code 7: production location.

code 8: production year.

code 9: production month.

code 10,11,12,13,14,15: serial number.

Note (1) Production Year

Year	1999	2000	2001	2002	2003	2004	2005	2006	2007	2008
Mark	9	0	1	2	3	4	5	6	7	8

Note (2) Production Month

Month	Jan.	Feb.	Mar.	Apr.	May.	Jun.	Jul.	Aug.	Sep.	Oct.	Nov.	Dec.
Mark	1	2	3	4	5	6	7	8	9	A	B	C

9.2 Location of Lot Mark

(1) The label is attached to the backside of the LCD module.

(2) This is subject to change without prior notice.



Lot mark

Document Title	HSD121MS11-A Product Information	Page No.	26 / 27
Document No.		Revision	1.0

10.0 GENERAL PRECAUTION

10.1 Use Restriction

This product is not authorized for use in life supporting systems, aircraft navigation control systems, military systems and any other application where performance failure could be life-threatening or otherwise catastrophic.

10.2 Disassembling or Modification

Do not disassemble or modify the module. It may damage sensitive parts inside LCD module, and may cause scratches or dust on the display. HannStar does not warrant the module, if customers disassemble or modify the module.

10.3 Breakage of LCD Panel

10.3.1 If LCD panel is broken and liquid crystal spills out, do not ingest or inhale liquid crystal, and do not contact liquid crystal with skin.

10.3.2 If liquid crystal contacts mouth or eyes, rinse out with water immediately.

10.3.3 If liquid crystal contacts skin or cloths, wash it off immediately with alcohol and rinse thoroughly with water.

10.3.4 Handle carefully with chips of glass that may cause injury, when the glass is broken.

10.4 Electric Shock

10.4.1 Disconnect power supply before handling LCD module.

10.4.2 Do not pull or fold the CCFL cable.

10.4.3 Do not touch the parts inside LCD modules and the fluorescent lamp's connector or cables in order to prevent electric shock.

10.5 Absolute Maximum Ratings and Power Protection Circuit

10.5.1 Do not exceed the absolute maximum rating values, such as the supply voltage variation, input voltage variation, variation in parts' parameters, environmental temperature, etc., otherwise LCD module may be damaged.

10.5.2 Please do not leave LCD module in the environment of high humidity and high temperature for a long time.

10.5.3 It's recommended to employ protection circuit for power supply.

10.6 Operation

10.6.1 Do not touch, push or rub the polarizer with anything harder than HB pencil lead.

10.6.2 Use fingerstalls of soft gloves in order to keep clean display quality, when persons handle the LCD module for incoming inspection or assembly.

10.6.3 When the surface is dusty, please wipe gently with absorbent cotton or other soft material.

Document Title	HSD121MS11-A Product Information	Page No.	27 / 27
Document No.		Revision	1.0

10.6.4 Wipe off saliva or water drops as soon as possible. If saliva or water drops contact with polarizer for a long time, they may causes deformation or color fading.

10.6.5 When cleaning the adhesives, please use absorbent cotton wetted with a little petroleum benzine or other adequate solvent.

10.7 Mechanism

Please mount LCD module by using mouting holes arranged in four corners tightly.

10.8 Static Electricity

10.8.1 Protection film must remove very slowly from the surface of LCD module to prevent from electrostatic occurrence.

10.8.2 Because LCD module use CMOS-IC on circuit board and TFT-LCD panel, it is very

weak to electrostatic discharge. Please be careful with electrostatic discharge.

Persons who handle the module should be grounded through adequate methods.

10.9 Strong Light Exposure

The module shall not be exposed under strong light such as direct sunlight. Otherwise, display characteristics may be changed.

10.10 Disposal

When disposing LCD module, obey the local environmental regulations.