



Document Title	HSD121PS11 Product Information	Page No.	1 / 31
Document No.		Revision	1.0

**To : SEBON**

**Date : January 21, 2003**

## **HannStar Product Information**

**Model : HSD121PS11  
-A**

- Note:
1. Please contact HannStar Display Corp., before designing your product based on this module specification.
  2. The information contained herein is presented merely to indicate the characteristics and performance of our products. No responsibility is assumed by HannStar for any intellectual property claims or other problems that may result from application based on the module described herein.



Document Title	HSD121PS11 Product Information	Page No.	2 / 31
Document No.		Revision	1.0

### Record of Revisions

Rev.	Date	Description of change
1.0	Dec.17, 2002	<ul style="list-style-type: none"><li>• HSD121PS11-A product information was first issued</li></ul>



Document Title	HSD121PS11 Product Information	Page No.	3 / 31
Document No.		Revision	1.0

### Contents

1.0	General descriptions .....	p.4
2.0	Absolute maximum ratings .....	p.5
3.0	Optical characteristics .....	p.7
4.0	Electrical characteristics .....	p.11
5.0	Block diagram .....	p.13
6.0	Interface pin connection .....	p.14
7.0	Interface timing .....	p.19
8.0	Outline dimension .....	p.22
9.0	Lot mark .....	p.24
10.0	Package specification .....	p.25
11.0	General precaution .....	p.27
12.0	Visual inspection specification .....	p.29

Document Title	HSD121PS11 Product Information	Page No.	4 / 31
Document No.		Revision	1.0

## 1.0 GENERAL DESCRIPTION

### 1.1 Introduction

HannStar Display model HSD121PS11-A is a color active matrix thin film transistor (TFT) liquid crystal display(LCD) that uses amorphous silicon TFT as a switching device. This model is composed of a TFT LCD panel, a driving circuit and a back light system. This TFT LCD has a 12.1 inch diagonally measured active display area with SVGA resolution (600 vertical by 800 horizontal pixel array) and can display up to 262,144 colors.

### 1.2 Features

- 12.1" SVGA for Notebook PC.
- LVDS interface system.

### 1.3 Applications

- Notebook PC
- OA equipment
- Display terminals
- Measuring Instrument
- New media equipment

### 1.4 General information

Item	Specification	Unit
Display area	246.0(H) x 184.5(V)	mm
Number of Pixel	800(H) x 600(V)	pixels
Pixel pitch	0.3075(H) x 0.3075(V)	mm
Pixel arrangement	RGB Vertical stripe	
Display color	262,144	colors
Display mode	Normally white	
Surface treatment	Antiglare, Hard-Coating(3H)	
Weight	420	g
Back-light	Single CCFL (Sidelight type)	
Input signal	1-ch LVDS	
Optimum viewing direction	6 o'clock	

Document Title	HSD121PS11 Product Information	Page No.	5 / 31
Document No.		Revision	1.0

### 1.5 Mechanical Information

Item		Min.	Typ.	Max.	Unit
Module Size	Horizontal(H)	274.5	275.0	275.5	Mm
	Vertical(V)	198.5	199.0	199.5	Mm
	Depth(D)	---	5.7	6.0	Mm
Weight (Without inverter)		---	420	430	G

## 2.0 ABSOLUTE MAXIMUM RATING

### 2.1 Absolute Rating of Environment

Item	Symbol	Min.	Max.	Unit	Note
Storage temperature	T <sub>STG</sub>	-20	60	°C	
Operating temperature	T <sub>OPR</sub>	0	50	°C	
Vibration(non-operating)	V <sub>nop</sub>	—	1.5	G	(1)
Shock(non-operating)	S <sub>nop</sub>	180	—	G	(2)
Storage humidity	H <sub>STG</sub>	10	90	%RH	(3)
Operating humidity	H <sub>OP</sub>	10	80	%RH	(3)
Low pressure(operating)	H <sub>LOP</sub>	697	--	hPa	(4)
Low pressure(non-operating)	H <sub>LNOP</sub>	116	--	hPa	(5)

Note (1)5-500-5Hz,sine wave, 30min/cycle, X/Y/Z each one cycle except for resonant frequency.

(2)2ms/±X,±Y,±Z direction, half-sine wave.

(3)Max wet bulb temp =39°C

(4)2 hours. (10000 feet)

(5)24 hours. (50000 feet)

Document Title	HSD121PS11 Product Information	Page No.	6 / 31
Document No.		Revision	1.0

## 2.2 Electrical Absolute Rating

### 2.2.1 TFT LCD Module

Item	Symbol	Min.	Max.	Unit	Note
Power supply voltage	$V_{DD}$	-0.3	4.0	V	(1)
Logic input voltage	$V_{IN}$	-0.3	VDD+0.3	V	(1)

### 2.2.2 Back-Light Unit

Item	Symbol	Min.	Max.	Unit	Note
Lamp voltage	$V_L$	0	730	$V_{rms}$	(1)
Lamp current	$I_L$	--	7.0	mA	(1)
Lamp frequency	$f_L$	0	100	kHz	(1)

Note (1) Permanent damage may occur to the LCD module if beyond this specification. Functional operation should be restricted to the conditions described under normally operating conditions.

Document Title	HSD121PS11 Product Information	Page No.	7 / 31
Document No.		Revision	1.0

### 3.0 OPTICAL CHARACTERISTICS

#### 3.1 Optical specification

Item		Symbol	Condition	Min.	Typ.	Max.	Unit	Note	
Contrast		CR	$\Theta=0$ $\Phi=0$ Normal viewing angle	150	300	—		(1)(2)	
Response time	Rising	$T_R$		—	15	20	msec	(1)(3)	
	Falling	$T_F$		—	30	40			
Average luminance of white(5 points)		$Y_L$			120	135	—	cd/m <sup>2</sup>	(1)(4)(5) ( $I_L=5.5mA$ )
Color chromaticity (CIE1931)	Red	$R_x$			0.563	0.593	0.623		(1)(4)
		$R_y$			0.302	0.332	0.362		
	Green	$G_x$			0.276	0.306	0.336		
		$G_y$			0.512	0.542	0.572		
	Blue	$B_x$			0.119	0.149	0.179		
		$B_y$			0.095	0.125	0.155		
	White	$W_x$		0.280	0.310	0.340			
		$W_y$		0.295	0.325	0.355			
Viewing angle	Hor.	$\Theta_L$	CR>10	—	40	—			
		$\Theta_R$		—	40	—			
	Ver.	$\Phi_H$		—	20	—			
		$\Phi_L$		—	40	—			
Brightness uniformity		$B_{UNI}$		65	—	—	%	(6)	

Document Title	HSD121PS11 Product Information	Page No.	8 / 31
Document No.		Revision	1.0

**3.2 Measuring Condition**

- Measuring surrounding : dark room
- Lamp current  $I_L$  : 5.5mA, lamp freq.  $F_L= 50\text{KHz}$
- $V_{DD}=3.3\text{V}\pm 0.3\text{V}$
- Surrounding temperature : 25°C
- 50min. warm-up time

**3.3 Measuring Equipment**

- LCD-7000 of Otsuka Electric Corp., which utilized MCPD-7000 for Chromaticity and BM-5A for other optical characteristics.
- Measuring spot size : 10~12mm

Note (1) Definition of Viewing Angle :

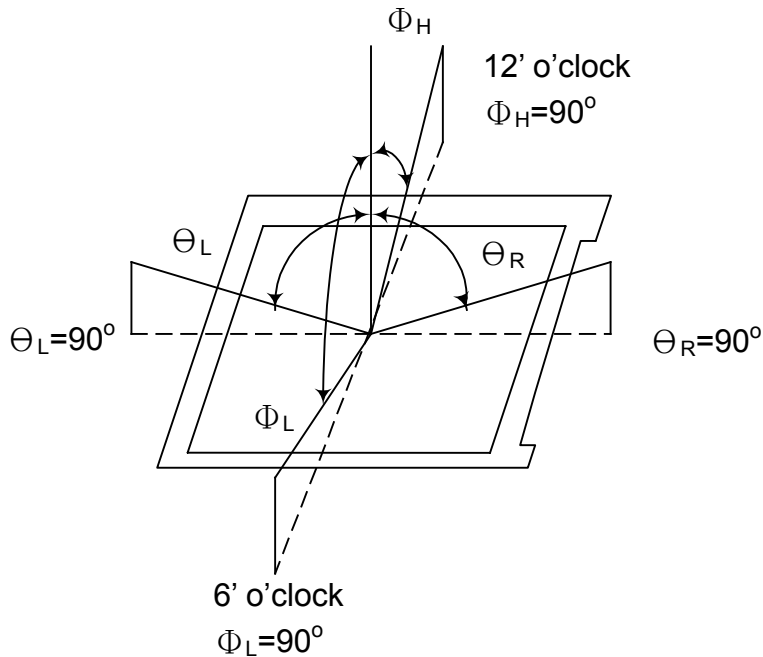

Note (2) Definition of Contrast Ratio(CR) :

measured at the center point of panel

$$CR = \frac{\text{Luminance with all pixels white}}{\text{Luminance with all pixels black}}$$



Document Title	HSD121PS11 Product Information	Page No.	9 / 31
Document No.		Revision	1.0

Note (3) Definition of Response Time : Sum of  $T_R$  and  $T_F$

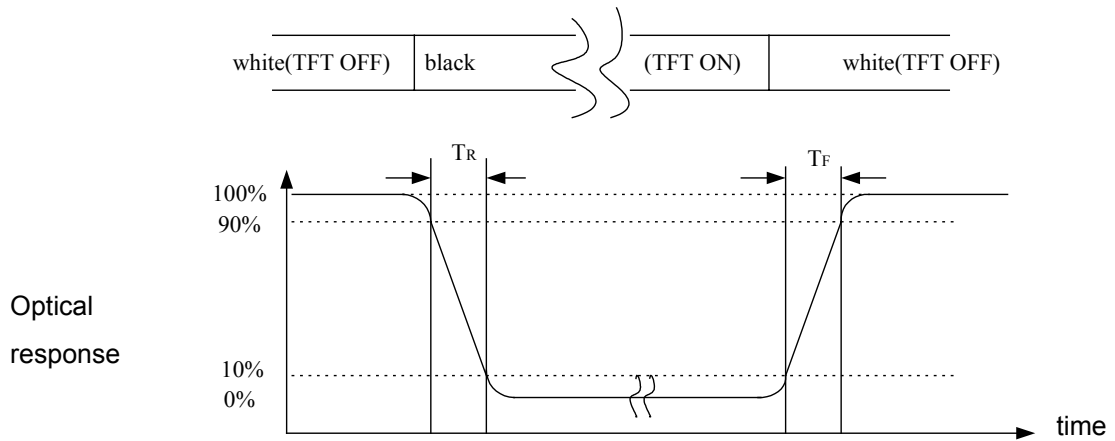

Note (4) Optical Characteristic Measurement Setup

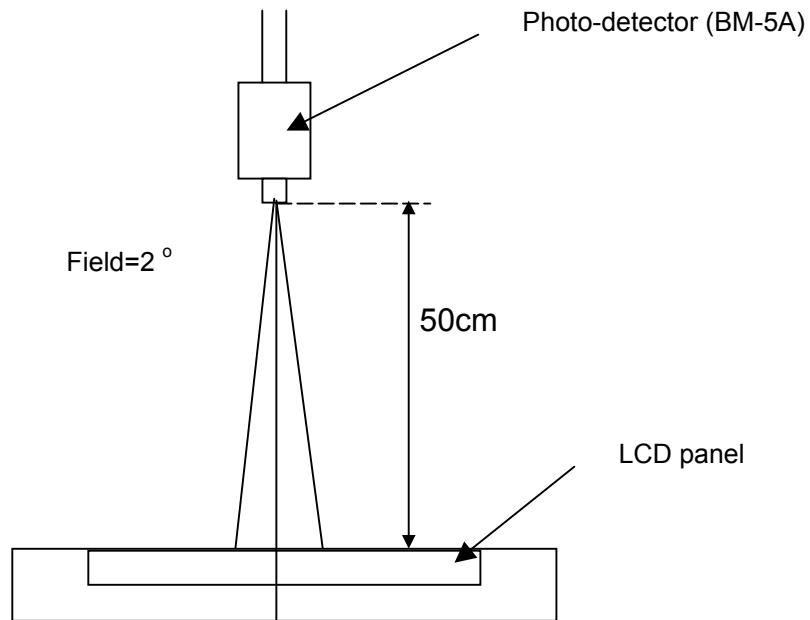

Document Title	HSD121PS11 Product Information	Page No.	10 / 31
Document No.		Revision	1.0

Note (5) Definition of Average Luminance of White: measured the luminance of white at 5 points

Average luminance of white

$$Y_{ave} = \frac{Y_1 + Y_2 + Y_3 + Y_4 + Y_5}{5}$$

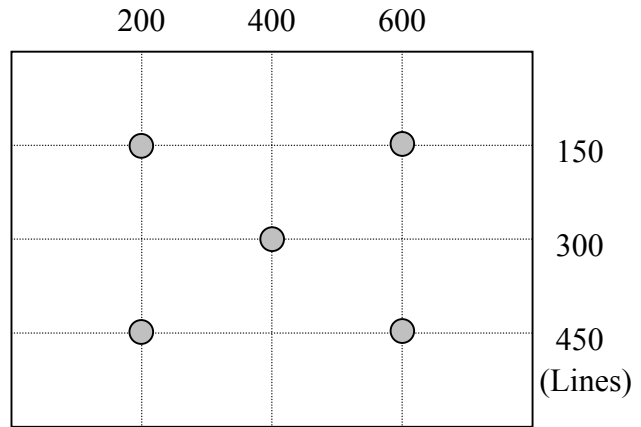

○ : Test point

Note (6) Definition of Brightness Uniformity

$$\text{Luminance uniformity} = \frac{(\text{Min Luminance of 13 points})}{(\text{Max Luminance of 13 points})} \times 100\%$$

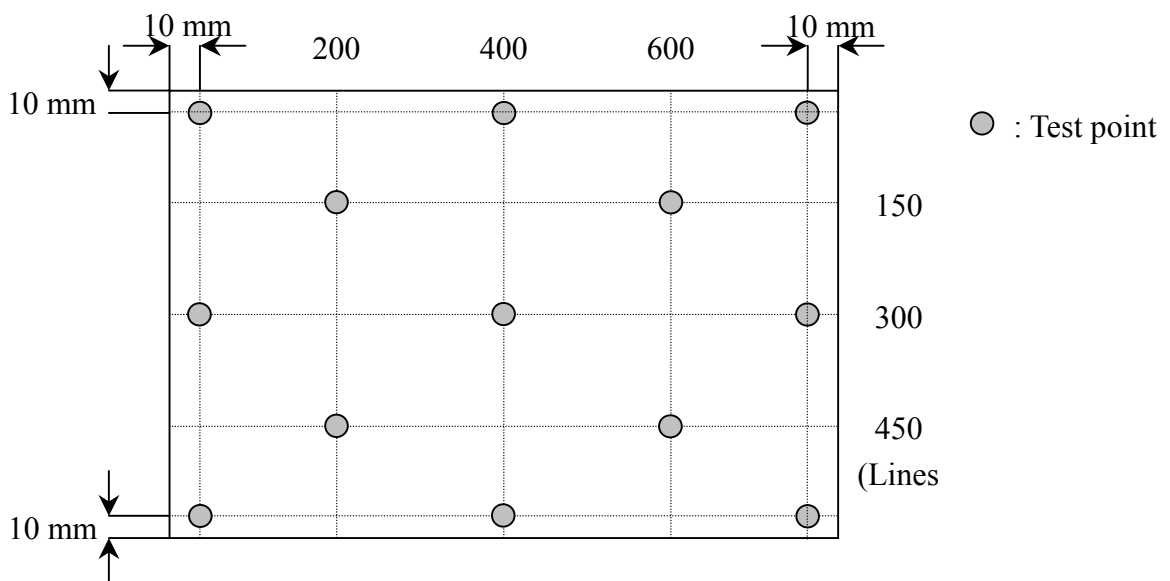

○ : Test point

Document Title	HSD121PS11 Product Information	Page No.	11 / 31
Document No.		Revision	1.0

## 4.0 ELECTRICAL CHARACTERISTICS

### 4.1 TFT LCD Module

Item	Symbol	Min.	Typ.	Max.	Unit	Note	
Voltage of power	$V_{DD}$	3.0	3.3	3.6	V		
Differential input threshold voltage	High	$V_{IH}$	—	—	100	mV	$V_{CM}=1.2$ V
	Low	$V_{IL}$	-100	—	—	mV	
Current of power supply	Mosaic	$I_{DD}$	—	415	—	mA	(1)
Vsync frequency	$f_V$	—	60	—	Hz	(2)	
Hsync frequency	$f_H$	—	37.9	—	kHz		
Main frequency	$f_{DCLK}$	38	40	42	MHz		

Note (1) Mosaic : Dot checker image

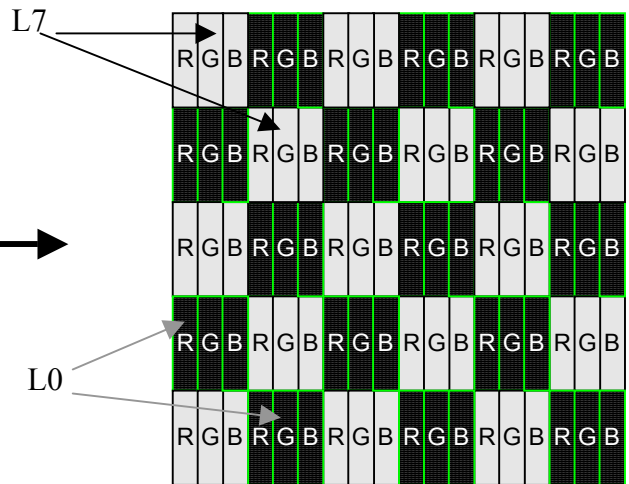

Grey scale: L0~L63.

L0: Luminance with all pixels black.

L63: Luminance with all pixels white.

Note (2) When  $f_V$  is too low, a flicker may be occurred on the display.

Document Title	HSD121PS11 Product Information	Page No.	12 / 31
Document No.		Revision	1.0

#### 4.2 Back-Light Unit

The back-light system is an edge-lighting type with 1 CCFL(Cold Cathode Fluorescent Lamp). The characteristics of the lamp is shown in the following tables.

Single CCFL, Side-light type

INVERTER: HIU-757.(1)

Item	Symbol	Min.	Typ.	Max.	Unit	Note
Lamp current	IL	3.0	5.5	6.0	mA(rms)	(1)
Lamp voltage	VL	--	650	--	V(rms)	$I_L=6.0mA$
Frequency	fL	40	50	60	KHz	(2)
Operating life time	Hr	10,000	--	--	Hour	(3)
Startup voltage	Vs	1120	--	--	V(rms)	at 25°C
		1580				at 0°C

Note (1) Lamp current is measured with current meter for high frequency as shown below. Specified valued are for a lamp.

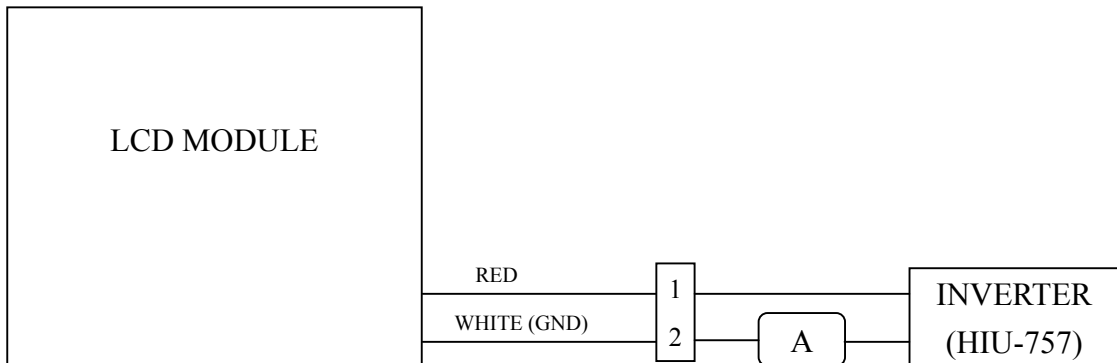

Note (2) Lamp frequency may produce interference with horizontal synchronous frequency and this may cause line flow on the display. Therefore lamp frequency shall be detached from the horizontal synchronous frequency and its harmonics as far as possible in order to avoid interference.

Note (3) Life time (Hr) can be defined as the time in which it continues to operate under the condition :  $T_a=25\sim35^\circ C$ ,  $I_L=5.5mA$ (typ) until one of the following event occurs :

1. When the brightness becomes 50%
2. When the effective ignition length becomes 90%

Document Title	HSD121PS11 Product Information	Page No.	13 / 31
Document No.		Revision	1.0

## 5.0 BLOCK DIAGRAM

### 5.1 TFT LCD Module

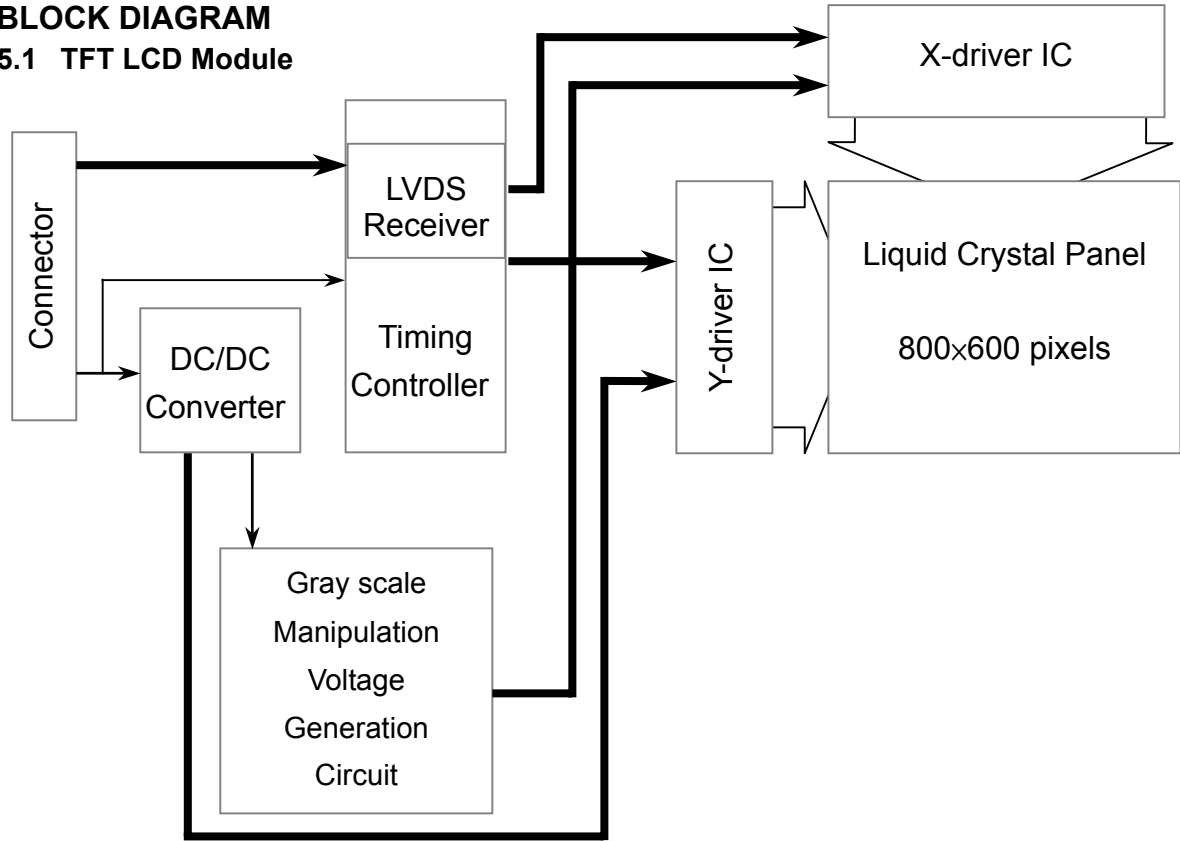

### 5.2 Back Light Unit



Document Title	HSD121PS11 Product Information	Page No.	14 / 31
Document No.		Revision	1.0

## 6.0 INTERFACE PIN CONNECTION

### 6.1 TFT LCD Module

Connector : JAE FI-SEB-20P-HF 10

Matching Socket : FI-SE20MR or FI-SE20M

Pin No.	Symbol	Function	Polarity	Remark
1	VDD	Power Supply : +3.3V	—	
2	VDD	Power Supply : +3.3V	—	
3	GND	Ground	—	
4	GND	Ground	—	
5	IN0-	Transmission Data of Pixels 0	Negative	
6	IN0+	Transmission Data of Pixels 0	Positive	
7	GND	Ground		
8	IN1-	Transmission Data of Pixels 1	Negative	
9	IN1+	Transmission Data of Pixels 1	Positive	
10	GND	Ground		
11	IN2-	Transmission Data of Pixels 2	Negative	
12	IN2+	Transmission Data of Pixels 2	Positive	
13	GND	Ground	—	
14	CLK-	Sampling Clock	Negative	
15	CLK+	Sampling Clock	Positive	
16	GND	Ground		
17	NC			
18	NC			
19	GND	Ground		
20	GND	Ground		

### 6.2 Back-Light Unit

Connector : JST BHSR-02VS-1

Mating Connector : SM02B-BHSS-1

Pin No	Input	Symbol	Function
1	HOT	VL	CCFL power supply (high voltage)
2	COLD	GL	CCFL power supply (low voltage)

Document Title	HSD121PS11 Product Information	Page No.	15 / 31
Document No.		Revision	1.0

### 6.3 Relationship Between Displayed Color and Input

	Display	MSB						LSB						Gray scale level						
		R5	R4	R3	R2	R1	R0	G5	G4	G3	G2	G1	G0		B5	B4	B3	B2	B1	B0
Basic color	Black	L	L	L	L	L	L	L	L	L	L	L	L	L	L	L	L	L	L	-
	Blue	L	L	L	L	L	L	L	L	L	L	L	L	H	H	H	H	H	H	-
	Green	L	L	L	L	L	L	H	H	H	H	H	H	L	L	L	L	L	L	-
	Light Blue	L	L	L	L	L	L	H	H	H	H	H	H	H	H	H	H	H	H	-
	Red	H	H	H	H	H	H	L	L	L	L	L	L	L	L	L	L	L	L	-
	Purple	H	H	H	H	H	H	L	L	L	L	L	L	H	H	H	H	H	H	-
	Yellow	H	H	H	H	H	H	H	H	H	H	H	H	L	L	L	L	L	L	-
	White	H	H	H	H	H	H	H	H	H	H	H	H	H	H	H	H	H	H	-
Gray scale of Red	Black	L	L	L	L	L	L	L	L	L	L	L	L	L	L	L	L	L	L	L0
	Dark ↑ ↓ Light	L	L	L	L	L	H	L	L	L	L	L	L	L	L	L	L	L	L	L1
		L	L	L	L	L	H	L	L	L	L	L	L	L	L	L	L	L	L	L2
		⋮	⋮	⋮	⋮	⋮	⋮	⋮	⋮	⋮	⋮	⋮	⋮	⋮	⋮	⋮	⋮	⋮	⋮	L3...L60
		H	H	H	H	L	H	L	L	L	L	L	L	L	L	L	L	L	L	L61
	H	H	H	H	H	L	L	L	L	L	L	L	L	L	L	L	L	L	L62	
	Red	H	H	H	H	H	H	L	L	L	L	L	L	L	L	L	L	L	L	Red L63
	Gray scale of Green	Black	L	L	L	L	L	L	L	L	L	L	L	L	L	L	L	L	L	L
Dark ↑ ↓ Light		L	L	L	L	L	L	L	L	L	L	L	H	L	L	L	L	L	L	L1
		L	L	L	L	L	L	L	L	L	L	H	L	L	L	L	L	L	L	L2
		⋮	⋮	⋮	⋮	⋮	⋮	⋮	⋮	⋮	⋮	⋮	⋮	⋮	⋮	⋮	⋮	⋮	⋮	L3...L60
		L	L	L	L	L	L	H	H	H	H	L	H	L	L	L	L	L	L	L61
L		L	L	L	L	L	H	H	H	H	H	L	L	L	L	L	L	L	L62	
Green		L	L	L	L	L	L	H	H	H	H	H	H	L	L	L	L	L	L	Green L63
Gray scale of Blue		Black	L	L	L	L	L	L	L	L	L	L	L	L	L	L	L	L	L	L
	Dark ↑ ↓ Light	L	L	L	L	L	L	L	L	L	L	L	L	L	L	L	L	L	H	L1
		L	L	L	L	L	L	L	L	L	L	L	L	L	L	L	L	H	L	L2
		⋮	⋮	⋮	⋮	⋮	⋮	⋮	⋮	⋮	⋮	⋮	⋮	⋮	⋮	⋮	⋮	⋮	⋮	L3...L60
		L	L	L	L	L	L	L	L	L	L	L	L	H	H	H	H	L	H	L61
	L	L	L	L	L	L	L	L	L	L	L	L	H	H	H	H	H	L	L62	
	Blue	L	L	L	L	L	L	L	L	L	L	L	L	H	H	H	H	H	H	Blue L63
	Gray scale of White & Black	Black	L	L	L	L	L	L	L	L	L	L	L	L	L	L	L	L	L	L
Dark ↑ ↓ Light		L	L	L	L	L	H	L	L	L	L	L	H	L	L	L	L	L	H	L1
		L	L	L	L	H	L	L	L	L	L	H	L	L	L	L	L	H	L	L2
		⋮	⋮	⋮	⋮	⋮	⋮	⋮	⋮	⋮	⋮	⋮	⋮	⋮	⋮	⋮	⋮	⋮	⋮	L3...L60
		H	H	H	H	L	H	H	H	H	H	L	H	H	H	H	H	L	H	L61
H		H	H	H	H	L	H	H	H	H	H	L	H	H	H	H	H	L	L62	
White		H	H	H	H	H	H	H	H	H	H	H	H	H	H	H	H	H	H	White L63

Document Title	HSD121PS11 Product Information	Page No.	16 / 31
Document No.		Revision	1.0

### 6.4 Pixel Format

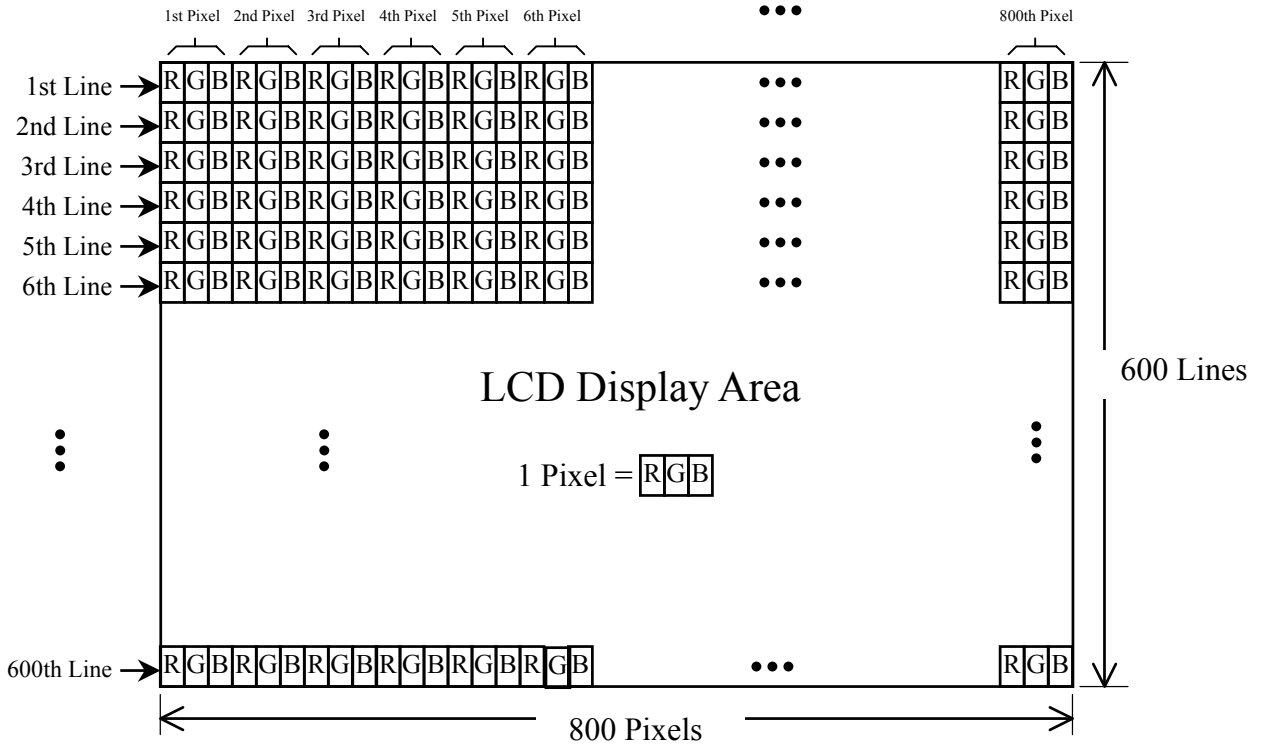



Document Title	HSD121PS11 Product Information	Page No.	17 / 31
Document No.		Revision	1.0

### 6.5 Recommended Transmitter to HSD121PS11-A Interface Assignment

#### Case1: 6bit Transmitter

DS90CF363 or equivalent						
Input terminal no.		Input signal (Graphics controller output signal)		Output signal	HSD121PS11-A interface(CN1)	
Symbol	Terminal	Symbol	Function	Symbol	Terminal	Symbol
TIN0	44	R0	RED Pixels Display Data (LSB)	TOUT0-  TOUT0+	No. 5 No. 6	IN0- IN0+
TIN1	45	R1	RED Pixels Display Data			
TIN2	47	R2	RED Pixels Display Data			
TIN3	48	R3	RED Pixels Display Data			
TIN4	1	R4	RED Pixels Display Data			
TIN5	3	R5	RED Pixels Display Data (MSB)			
TIN6	4	G0	RED Pixels Display Data (LSB)	TOUT1-  TOUT1+	No. 7 No. 8	IN1- IN1+
TIN7	6	G1	GREEN Pixels Display Data			
TIN8	7	G2	GREEN Pixels Display Data			
TIN9	9	G3	GREEN Pixels Display Data			
TIN10	10	G4	GREEN Pixels Display Data			
TIN11	12	G5	GREEN Pixels Display Data (MSB)			
TIN12	13	B0	BLUE Pixels Display Data (LSB)	TOUT2-  TOUT2+	No. 9 No. 10	IN2- IN2+
TIN13	15	B1	BLUE Pixels Display Data			
TIN14	16	B2	BLUE Pixels Display Data			
TIN15	18	B3	BLUE Pixels Display Data			
TIN16	19	B4	BLUE Pixels Display Data			
TIN17	20	B5	BLUE Pixels Display Data (MSB)			
TIN18	22	NC	Non Connection (open)	TOUT2+	No. 9 No. 10	IN2- IN2+
TIN19	23	NC	Non Connection (open)			
TIN20	25	ENAB	Compound Synchronization Signal			
CLK IN	26	NCLK	Data Sampling Clock	TCLK OUT- TCLK OUT+	No. 11 No. 12	CLK IN- CLK IN+

Note : Please connect NC pin to nothing. Don't connect it to ground nor to other signal input.

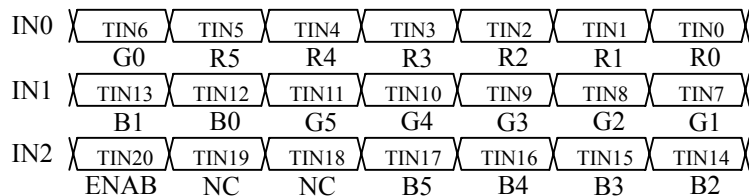

Document Title	HSD121PS11 Product Information	Page No.	18 / 31
Document No.		Revision	1.0

**Case2 : 8bit Transmitter**

DS90CF383 or equivalent						
Input terminal no.		Input signal (Graphics control output signal)		Output signal	To HSD121PS11-A interface(CN1)	
Symbol	Terminal	Symbol	Function	Symbol	Terminal	Symbol
TIN0	51	R0	RED Pixels Display Data (LSB)	TOUT0- TOUT0+	No. 5 No. 6	IN0- IN0+
TIN1	52	R1	RED Pixels Display Data			
TIN2	54	R2	RED Pixels Display Data			
TIN3	55	R3	RED Pixels Display Data			
TIN4	56	R4	RED Pixels Display Data			
TIN6	3	R5	RED Pixels Display Data (MSB)	TOUT1- TOUT1+	NO.7 NO.8	IN1- IN1+
TIN7	4	G0	GREEN Pixels Display Data (LSB)			
TIN8	6	G1	GREEN Pixels Display Data			
TIN9	7	G2	GREEN Pixels Display Data			
TIN12	11	G3	GREEN Pixels Display Data			
TIN13	12	G4	GREEN Pixels Display Data	TOUT2- TOUT2+	NO.9 NO.10	IN2- IN2+
TIN14	14	G5	GREEN Pixels Display Data (MSB)			
TIN15	15	B0	BLUE Pixels Display Data (LSB)			
TIN18	19	B1	BLUE Pixels Display Data			
TIN19	20	B2	BLUE Pixels Display Data			
TIN20	22	B3	BLUE Pixels Display Data	TOUT3- TOUT3+	NA	NA
TIN21	23	B4	BLUE Pixels Display Data			
TIN22	24	B5	BLUE Pixels Display Data (MSB)			
TIN24	27	NC	Non Connection (open)			
TIN25	28	NC	Non Connection (open)			
TIN26	30	ENAB	Compound Synchronization Signal	TCLK OUT- TCLK OUT+	NO. 11 NO. 12	CLK IN- CLK IN+
TIN27	50	NC	Non Connection (open)			
TIN5	2	NC	Non Connection (open)			
TIN10	8	NC	Non Connection (open)			
TIN11	10	NC	Non Connection (open)			
TIN16	16	NC	Non Connection (open)			
TIN17	18	NC	Non Connection (open)			
TIN23	25	NC	Non Connection (open)			
CLK IN	31	NCLK	DATA SAMPLING CLOCK			

Note : Please connect NC pin to nothing. Don't connect it to ground nor to other signal input.

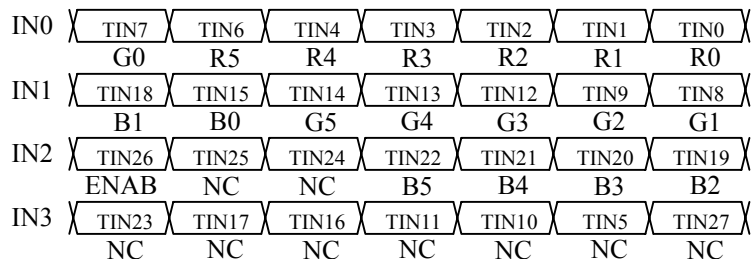

Document Title	HSD121PS11 Product Information	Page No.	19 / 31
Document No.		Revision	1.0

## 7.0 INTERFACE TIMING <sup>1)2)3)4)5)6)</sup>

### 7.1 Timing Parameters (DE mode)

Item	Symbol	Min.	Typ.	Max.	Unit	Remarks
Frame period	t1	627×t3 —	628×t3 16.58	664×t3 —	— ms	1) 5)
Vertical display term	t2	600×t3 —	600×t3 15.84	600×t3 —	— ms	1)
One line Scanning time	t3	1020×t5 —	1056×t5 26.4	1100×t5 —	— μs	1) 5)
Horizontal display term	t4	800×t5 —	800×t5 20.0	800×t5 —	— μs	1)
Clock period	t5	21.0	25.0	—	ns	5)

Note 1) Refer to TIMING CHART at page19, 20 and LVDS specification (DS90CF364MTD) by National Semiconductor Corporation.

Note 2) When ENAB is fixed to “H” level or “L” level after NCLK is supplied, the panel displays black with some flicker.

Note 3) If NCLK is fixed to “H” level or “L” level, for certain period while ENAB is supplied, the panel may be damaged.

Note 4) Do not make t1 and t3’s fluctuate. If t1 or t3 is fluctuating, the panel displays black.

Note 5) Please adjust LCD operating signal timing and FL driving frequency, to optimize the display quality. There is a possibility that flicker is observed by the interference of LCD operating signal timing and FL driving condition (especially driving frequency).

Note 6) All input condition (level & timing) refers to SII211 specification by Silicon Image Inc.

Document Title	HSD121PS11 Product Information	Page No.	20 / 31
Document No.		Revision	1.0

### 7.2 Timing Diagram of Interface Signal (DE mode)

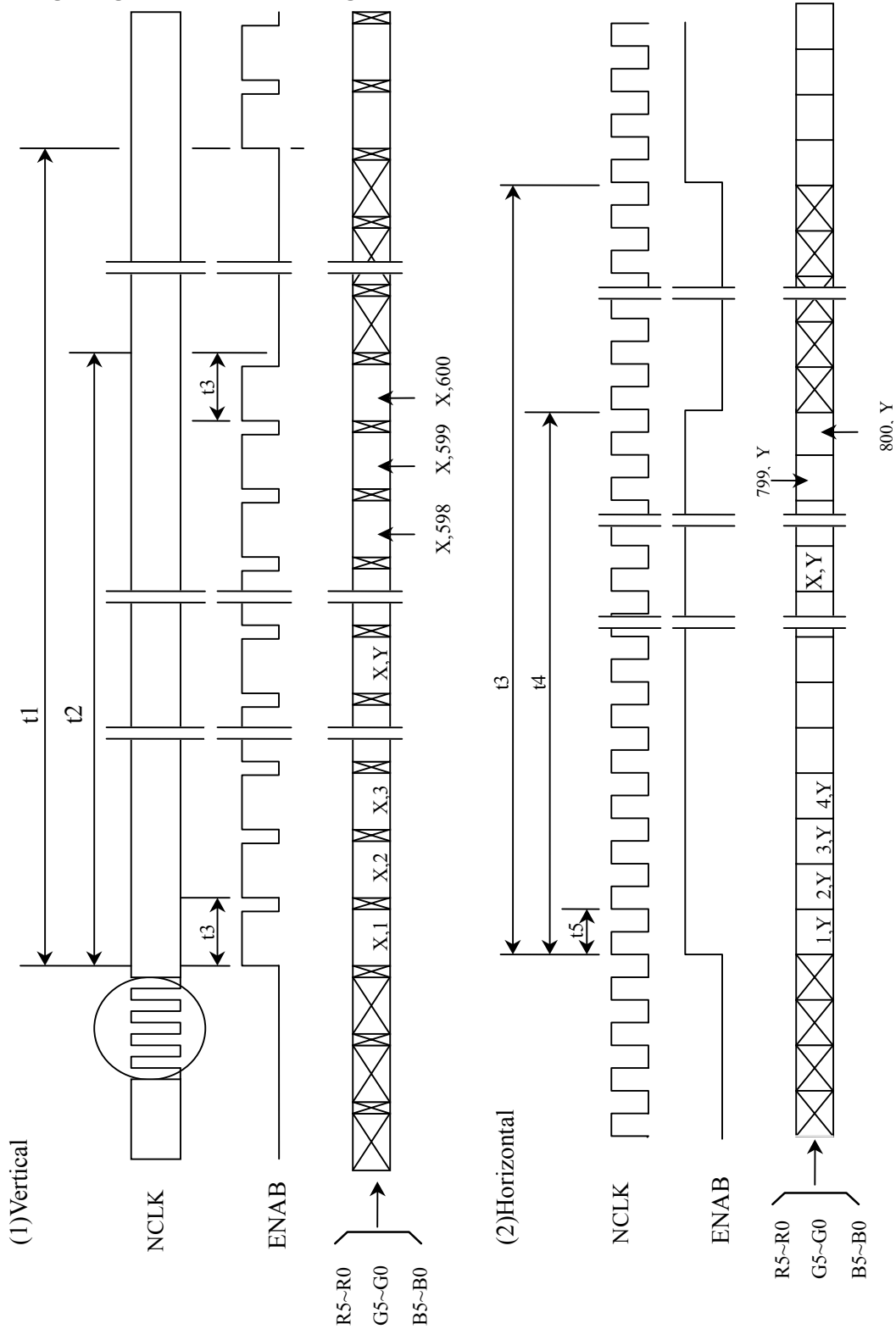

Document Title	HSD121PS11 Product Information	Page No.	21 / 31
Document No.		Revision	1.0

### 7.3 Power ON/OFF Sequence

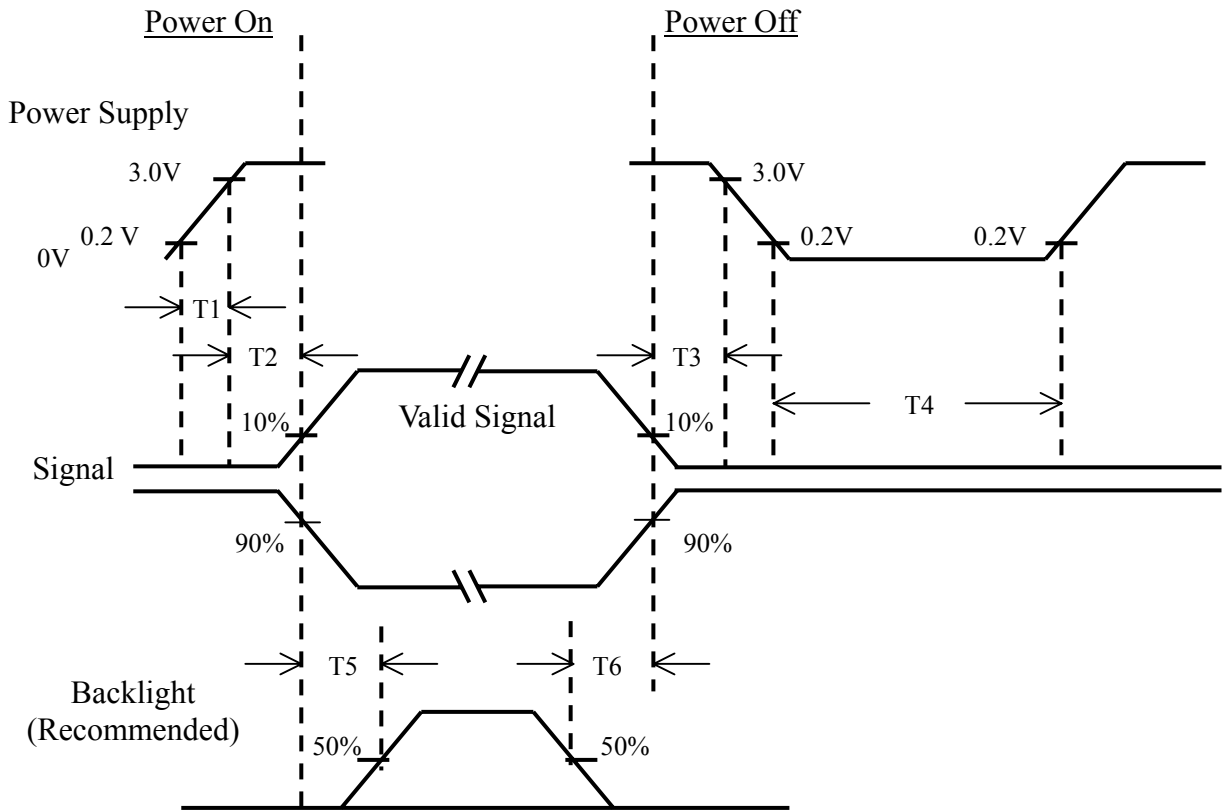

Power ON/OFF Sequence

Item	Min.	Typ.	Max.	Unit	Remark
T1	0	—	10	msec	
T2	50	—	55	msec	
T3	0	—	40	msec	
T4	500	—	—	msec	
T5	200	—	—	msec	
T6	200	—	—	msec	

- (1) The supply voltage of the external system for the module input should be the same as the definition of  $V_{DD}$ .
- (2) Apply the lamp voltage within the LCD operation range. When the back-light turns on before the LCD operation or the LCD turns off before the back-light turns off, the display may momentarily become white.
- (3) In case of  $V_{DD}$  = off level, please keep the level of input signal on the low or keep a high impedance.
- (4) T4 should be measured after the module has been fully discharged between power off and on period.
- (5) Interface signal shall not be kept at high impedance when the power is on.

Document Title	HSD121PS11 Product Information	Page No.	22 / 31
Document No.		Revision	1.0

## 8.0 OUTLINE DIMENSION

### (1) Front view outline dimension

Unit: mm

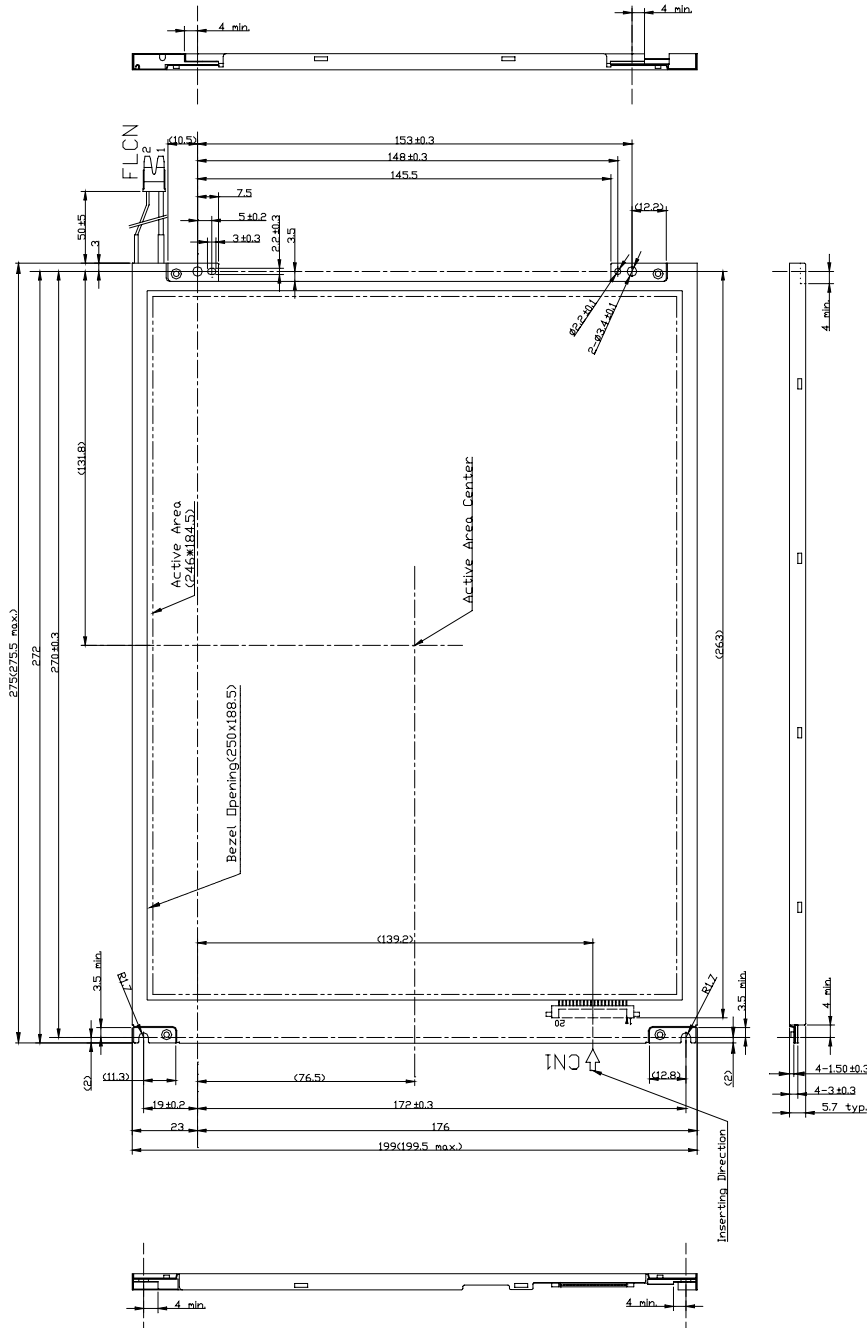

Note:  
Unspecified dimensional tolerances are ±0.5

CN1:F1-SEB20P-HF10(JAE)  
FLCN:BHSR-02VS-1(CJT)

Document Title	HSD121PS11 Product Information	Page No.	23 / 31
Document No.		Revision	1.0

**(2) Back view outline dimension**

**Unit: mm**

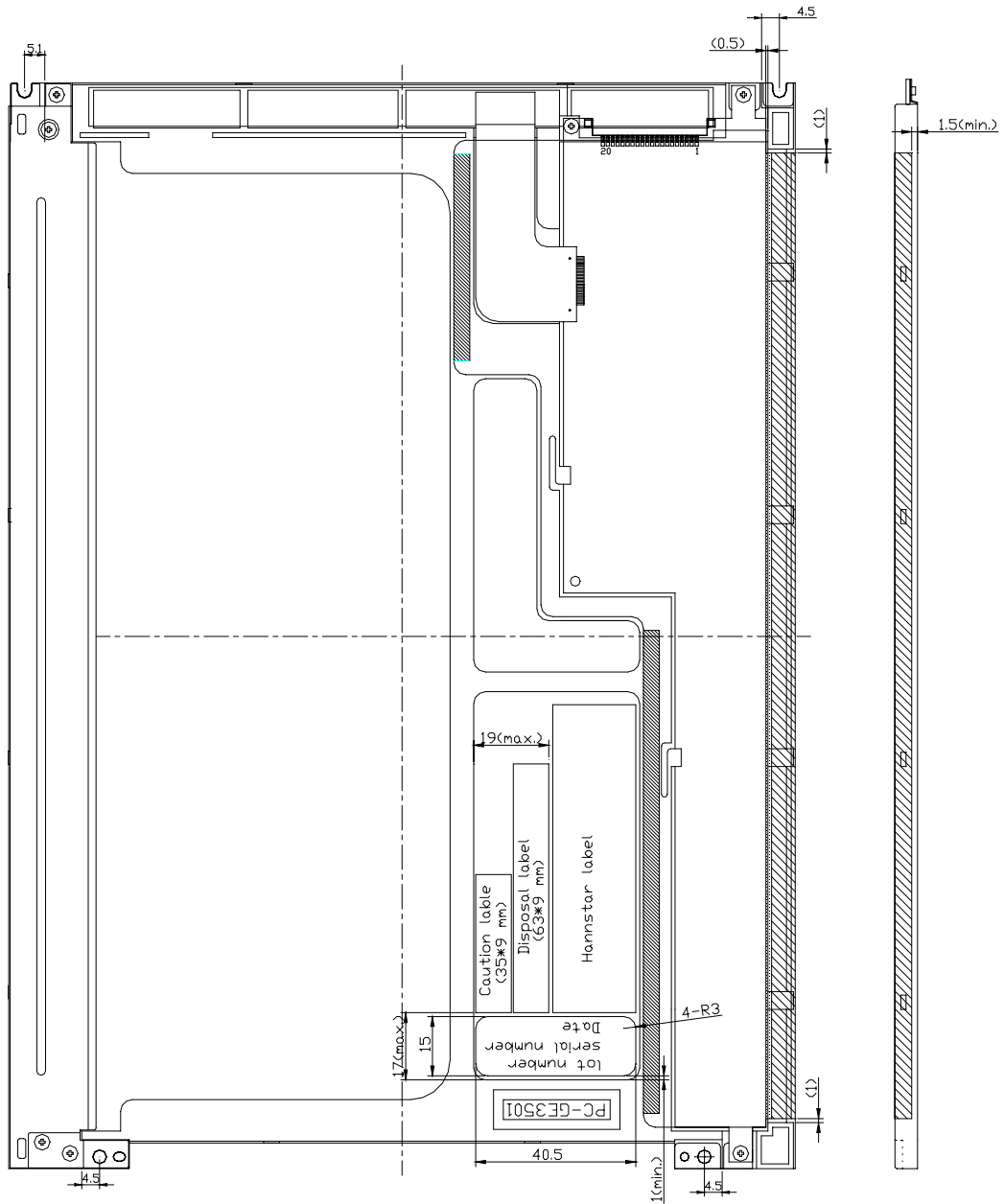

Document Title	HSD121PS11 Product Information	Page No.	24 / 31
Document No.		Revision	1.0

## 9.0 LOT MARK

### 9.1 Lot Mark



code 1,2,3,4,5,6: HannStar internal flow control code.

code 1,2:product code

code 5,6:sub product code(the code will be as same as package box)

code 7: production location.

code 8: production year.

code 9: production month.

code 10,11,12,13,14,15: serial number.

Note (1) Production Year

Year	1999	2000	2001	2002	2003	2004	2005	2006	2007	2008
Mark	9	0	1	2	3	4	5	6	7	8

Note (2) Production Month

Month	Jan.	Feb.	Mar.	Apr.	May.	Jun.	Jul.	Aug.	Sep.	Oct	Nov.	Dec.
Mark	1	2	3	4	5	6	7	8	9	A	B	C

### 9.2 Location of Lot Mark

(1) The label is attached to the backside of the LCD module.

(2) This is subject to change without prior notice.

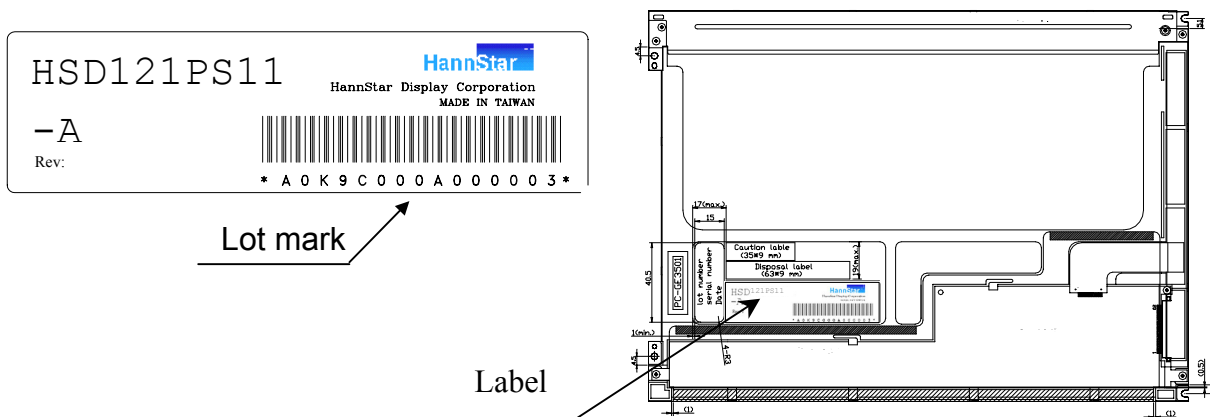



Document Title	HSD121PS11 Product Information	Page No.	25 / 31
Document No.		Revision	1.0

## 10.0 PACKAGE SPECIFICATION

### 10.1 packing form

- (1) package quantity in one carton: 15 pieces.
- (2) carton size: 453±3 mm×360±3 mm×285±3 mm.
- (3) for domestic transportation only.

### 10.2 packing assembly drawings

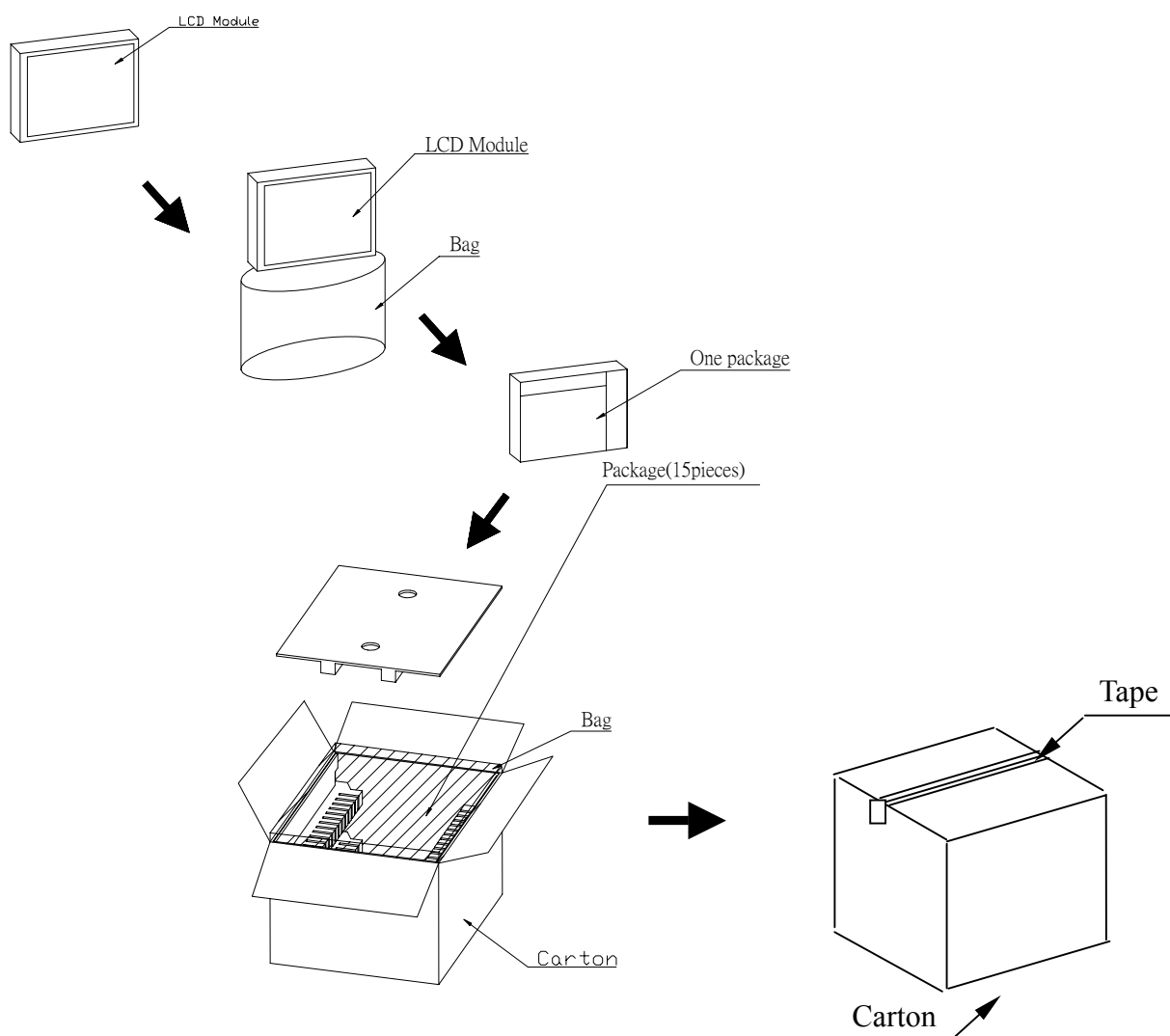

Document Title	HSD121PS11 Product Information	Page No.	26 / 31
Document No.		Revision	1.0

### 10.3 Pallet transportation specification

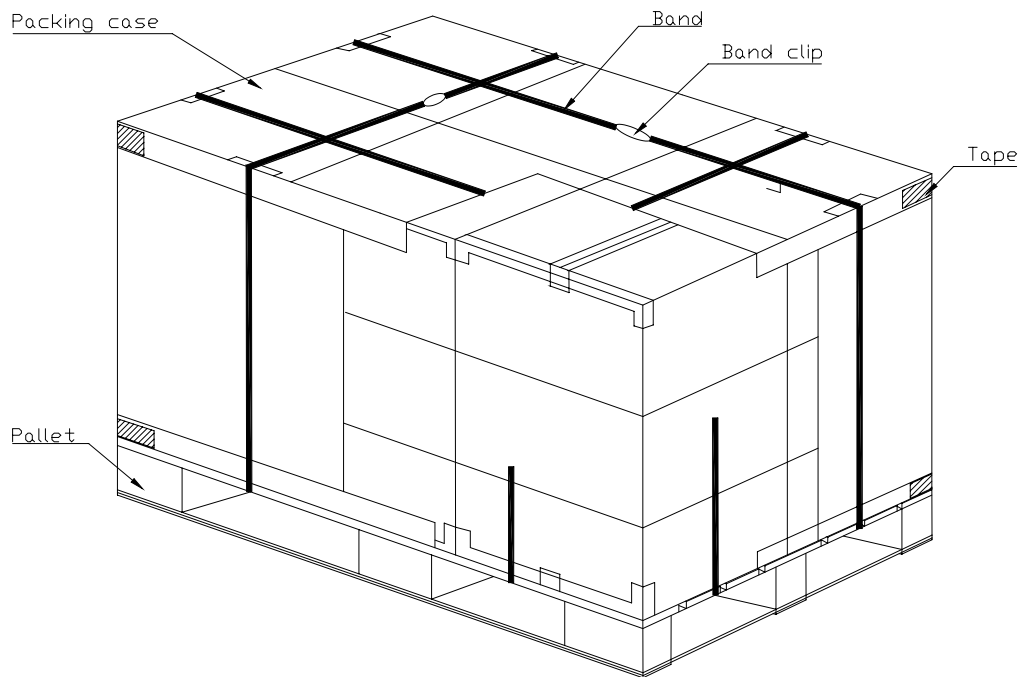

1 Pallet=18 cartons (2X3X3)

Document Title	HSD121PS11 Product Information	Page No.	27 / 31
Document No.		Revision	1.0

## 11.0 GENERAL PRECAUTION

### 11.1 Use Restriction

This product is not authorized for use in life supporting systems, aircraft navigation control systems, military systems and any other application where performance failure could be life-threatening or otherwise catastrophic.

### 11.2 Disassembling or Modification

Do not disassemble or modify the module. It may damage sensitive parts inside LCD module, and may cause scratches or dust on the display. HannStar does not warrant the module, if customers disassemble or modify the module.

### 11.3 Breakage of LCD Panel

- 11.3.1 If LCD panel is broken and liquid crystal spills out, do not ingest or inhale liquid crystal, and do not contact liquid crystal with skin.
- 11.3.2 If liquid crystal contacts mouth or eyes, rinse out with water immediately.
- 11.3.3 If liquid crystal contacts skin or cloths, wash it off immediately with alcohol and rinse thoroughly with water.
- 11.3.4 Handle carefully with chips of glass that may cause injury, when the glass is broken.

### 11.4 Electric Shock

- 11.4.1 Disconnect power supply before handling LCD module.
- 11.4.2 Do not pull or fold the CCFL cable.
- 11.4.3 Do not touch the parts inside LCD modules and the fluorescent lamp's connector or cables in order to prevent electric shock.

### 11.5 Absolute Maximum Ratings and Power Protection Circuit

- 11.5.1 Do not exceed the absolute maximum rating values, such as the supply voltage variation, input voltage variation, variation in parts' parameters, environmental temperature, etc., otherwise LCD module may be damaged.
- 11.5.2 Please do not leave LCD module in the environment of high humidity and high temperature for a long time.
- 11.5.3 It's recommended to employ protection circuit for power supply.

### 11.6 Operation

- 11.6.1 Do not touch, push or rub the polarizer with anything harder than HB pencil lead.
- 11.6.2 Use fingerstalls of soft gloves in order to keep clean display quality, when persons handle the LCD module for incoming inspection or assembly.
- 11.6.3 When the surface is dusty, please wipe gently with absorbent cotton or other soft material.

Document Title	HSD121PS11 Product Information	Page No.	28 / 31
Document No.		Revision	1.0

11.6.4 Wipe off saliva or water drops as soon as possible. If saliva or water drops contact with polarizer for a long time, they may causes deformation or color fading.

11.6.5 When cleaning the adhesives, please use absorbent cotton wetted with a little petroleum benzine or other adequate solvent.

### **11.7 Mechanism**

Please mount LCD module by using mouting holes arranged in four corners tightly.

### **11.8 Static Electricity**

11.8.1 Protection film must remove very slowly from the surface of LCD module to prevent from electrostatic occurrence.

11.8.2 Because LCD module use CMOS-IC on circuit board and TFT-LCD panel, it is very weak to electrostatic discharge. Please be careful with electrostatic discharge.

Persons who handle the module should be grounded through adequate methods.

### **11.9 Strong Light Exposure**

The module shall not be exposed under strong light such as direct sunlight. Otherwise, display characteristics may be changed.

### **11.10 Disposal**

When disposing LCD module, obey the local environmental regulations.

Document Title	HSD121PS11 Product Information	Page No.	29 / 31
Document No.		Revision	1.0

## 12.0 VISUAL INSPECTION SPECIFICATION

Inspection condition is as followings

- Viewing distance is approximately 15-50 cm
- Viewing angle is normal to the LCD panel
- Ambient temperature is in the room temperature
- Ambient illumination is 300~500 Lux

	Defect type	Criteria	
Visual defect	Dark/ Bright Spot	$0.2 \text{ mm} \leq D < 0.6 \text{ mm}$	
	Circular Foreign Material	$N \leq 4$	
D: diameter	Bright or Dark Line	$0.03 \text{ mm} \leq W < 0.07 \text{ mm}$	
	Foreign Material	$L \leq 2 \text{ mm}$ $N \leq 4$	
N: number	Polarizer/ Linear Scratch	$0.05 \text{ mm} \leq W < 0.07 \text{ mm}$	
W: horizontal width		$L \leq 3 \text{ mm}$ $N \leq 3$	
L: vertical high	Polarizer- Bubble/ Peeling	$0.15 \leq D < 0.35 \text{ mm}$ $N \leq 4$	
	Maximum Allowable Defect Count All Types	$N \leq 7$	
Electrical defect	Bright Dot Random	$N \leq 4$	
	Bright Dot – Green	$N \leq 2$	
	Bright Dot- 2 Adjacent	$N \leq 2$	
	N: number	Dark Dots- Random	$N \leq 7$
		Dark Dots- 2 Adjacent	$N \leq 3$
		Dark Dots- 3 or More Adjacent	$N = 0$
		Total Bright and Dark Dots	$N \leq 8$
		Minimum Distance Between Bright Dots	$\geq 15 \text{ mm}$
		Minimum Distance Between Dark Dots	$\geq 5 \text{ mm}$
		Minimum Distance Between Bright Dots and Dark Dots	$\geq 10 \text{ mm}$

Document Title	HSD121PS11 Product Information	Page No.	30 / 31
Document No.		Revision	1.0

Note (1) Bright dot defect description  
- Two adjacent

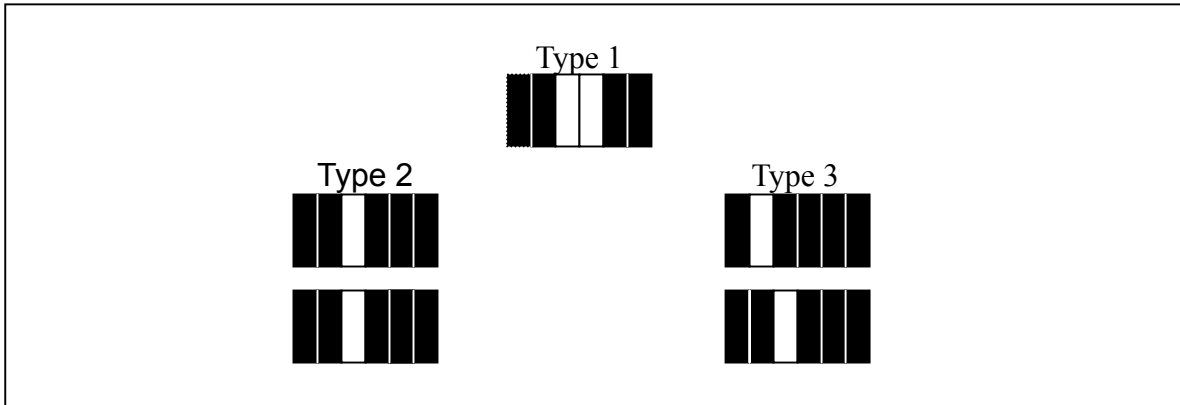

Note (2) Dark dot defect description  
- Two adjacent

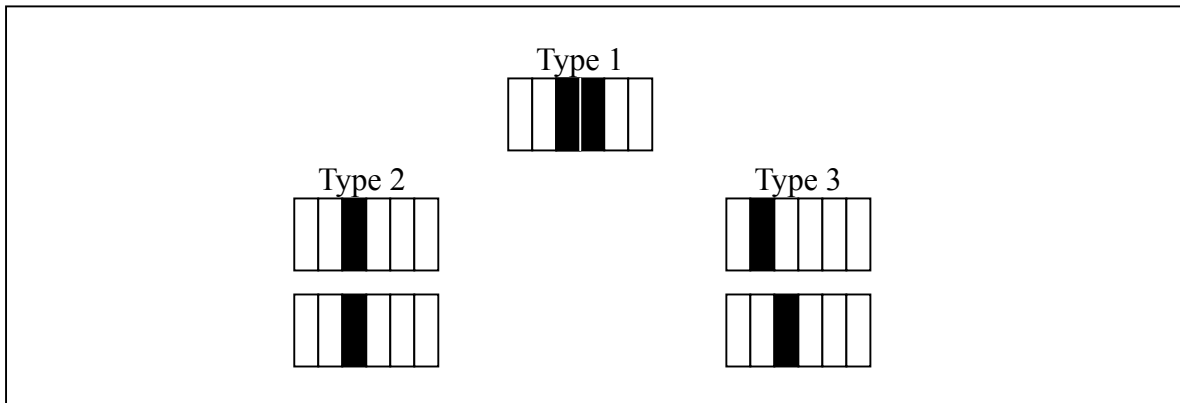

Note (3) Dark dot defect description  
- Three adjacent

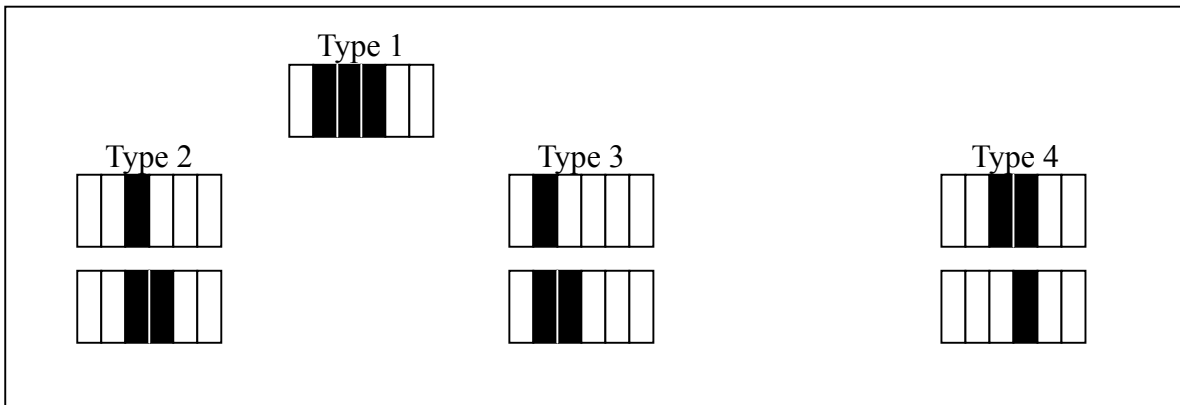

Document Title	HSD121PS11 Product Information	Page No.	31 / 31
Document No.		Revision	1.0

Note (4) Minimum distance between dot defects

Bright dot to bright dot

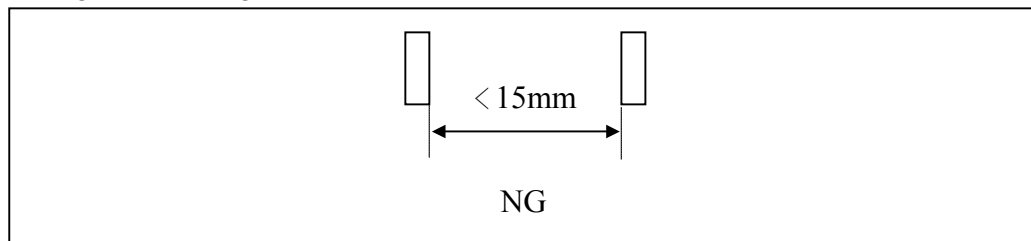

Dark dot to dark dot

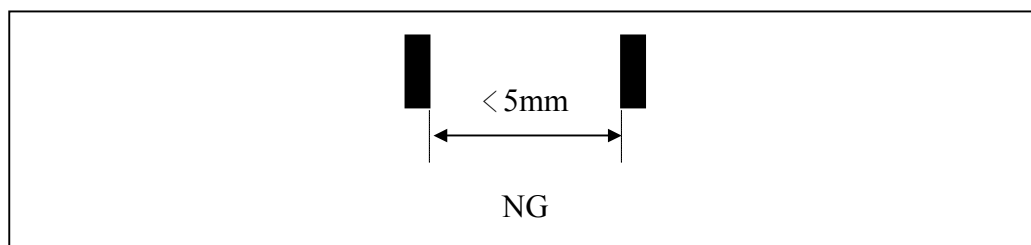

Bright dot to dark dot

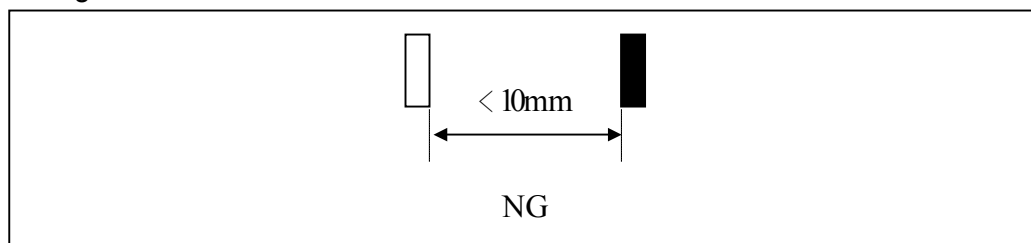

Note (6) "Average Diameter" description

Dusts would be judged by "Average Diameter" under vertical high  $\geq 0.1$  mm and horizontal width  $\leq 0.1$ mm condition..

Average Diameter =  $(a+b)/2$

