



Document Title	HSD121PX12-A Product Information	Page No.	1 / 26
Document No.		Revision	1.0

HannStar Product Information

Model : **HSD121PX12**
-A

- Note :
1. Please contact HannStar Display Corp. before designing your product based on this module specification.
 2. The information contained herein is presented merely to indicate the characteristics and performance of our products. No responsibility is assumed by HannStar for any intellectual property claims or other problems that may result from application based on the module described herein.



Document Title	HSD121PX12-A Product Information	Page No.	2 / 26
Document No.		Revision	1.0

Record of Revisions

Rev.	Date	Description of change
1.0	27 May 2003	HSD121PX12-A Product Information was first issued.



Document Title	HSD121PX12-A Product Information	Page No.	3 / 26
Document No.		Revision	1.0

Contents

1.0	General descriptions	p.4
2.0	Absolute maximum ratings	p.5
3.0	Optical characteristics	p.7
4.0	Electrical characteristics	p.11
5.0	Block diagram	p.13
6.0	Interface pin connection	p.14
7.0	Interface timing	p.19
8.0	Outline dimension	p.22
9.0	Lot mark	p.24
10.0	General precaution	p.25

Document Title	HSD121PX12-A Product Information	Page No.	4 / 26
Document No.		Revision	1.0

1.0 GENERAL DESCRIPTION

1.1 Introduction

HannStar Display model HSD121PX12-A is a color active matrix thin film transistor (TFT) liquid crystal display(LCD) that uses amorphous silicon TFT as a switching device. This model is composed of a TFT LCD panel, a driving circuit and a back light system. This TFT LCD has a 12.1 inch diagonally measured active display area with XGA resolution (768 vertical by 1024 horizontal pixel array) and can display up to 262,144 colors.

1.2 Features

- 12.1" XGA for Notebook PC.
- 3.3V LVDS interface system, DE (Data Enable) only mode.

1.3 Applications

- Notebook PC.
- OA equipment.
- Display terminals.
- Measuring Instrument.
- New media equipment.

1.4 General information

Item	Specification	Unit
Display area	245.76(H) x 184.32(V)	Mm
Number of Pixel	1024(H) x 768(V)	Pixels
Pixel pitch	0.240(H) x 0.240(V)	Mm
Pixel arrangement	RGB Vertical stripe	
Display color	262,144	Colors
Display mode	Normally white	
Surface treatment	Antiglare, Hard-Coating(3H)	
Weight	290	g
Back-light	Single CCFL (Sidelight type)	
Input signal	1-ch LVDS	
Optimum viewing direction	6 o'clock	

Document Title	HSD121PX12-A Product Information	Page No.	5 / 26
Document No.		Revision	1.0

1.5 Mechanical Information

Item		Min.	Typ.	Max.	Unit
Module Size	Horizontal(H)	260.5	261.0	261.5	mm
	Vertical(V)	198.5	199.0	199.5	mm
	Depth(D)	---	---	5.2	mm
Weight (Without inverter)		---	290	---	g

2.0 ABSOLUTE MAXIMUM RATING

2.1 Absolute Rating of Environment

Item	Symbol	Min.	Max.	Unit	Note
Storage temperature	T _{STG}	-20	60	°C	
Operating temperature	T _{OPR}	0	50	°C	
Vibration(non-operating)	V _{NOP}	--	1.5	G	(1)
Shock (non-operating)	S _{NOP}	180	--	G	(2)
Storage humidity	H _{STG}	10	90	%RH	(3)
Operating humidity	H _{OP}	10	80	%RH	(3)
Low pressure(operating)	P _{LOP}	697	--	hPa	(4)
Low pressure(non-operating)	P _{LNOP}	116	--	hPa	(5)

Note: (1) 5-500Hz sweep/cycle, sine wave, X, Y,Z each directions, 30 minutes each.

(2) 3ms, ±X,±Y,±Z direction, one time each, half sine wave. For this shock test, it is necessary to fill the silicon rubber between the shock jig as buffer.

(3) Max. wet bulb temp =39°C

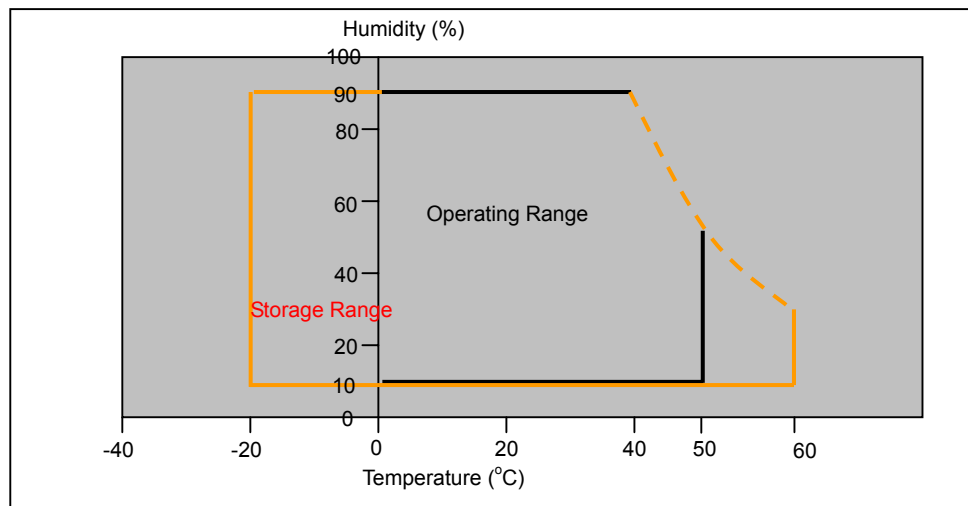

(4) 2 hours. (10000 feet)

(5) 24 hours. (50000 feet)

Document Title	HSD121PX12-A Product Information	Page No.	6 / 26
Document No.		Revision	1.0

2.2 Electrical Absolute Rating

2.2.1 TFT LCD Module

Item	Symbol	Min.	Max.	Unit	Note
Power supply voltage	V_{DD}	-0.3	4.0	V	(1)
Logic input voltage	V_{IN}	-0.3	VDD+0.3	V	(1)

2.2.2 Back-Light Unit

Item	Symbol	Min.	Max.	Unit	Note
Lamp voltage	V_L	0	2000	V_{rms}	(1)
Lamp current	I_L	2.0	7.0	mA	(1)
Lamp frequency	f_L	30	80	kHz	(1)

Note (1) Permanent damage may occur to the LCD module if beyond this specification.
Functional operation should be restricted to the conditions described under normally operating conditions.

Document Title	HSD121PX12-A Product Information	Page No.	7 / 26
Document No.		Revision	1.0

3.0 OPTICAL CHARACTERISTICS

3.1 Optical specification

Item	Symbol	Condition	Min.	Typ.	Max.	Unit	Note	
Contrast	CR	$\Theta=0$ $\Phi=0$ Normal Viewing Angle	—	250	—		(1)(2)	
Response time	Rising		T_R	—	$T_R+T_F=35$	—	msec	(1)(3)
	Falling		T_F	—		—		
White luminance (center of screen)	Y_L			120	150	—	cd/m ²	(1)(4)
Color chromaticity (CIE1931)	Red		R_x	0.568	0.598	0.628		
			R_y	0.304	0.334	0.364		
	Green		G_x	0.291	0.321	0.351		
			G_y	0.526	0.556	0.586		
	Blue		B_x	0.120	0.150	0.180		
			B_y	0.093	0.123	0.153		
	White	W_x	0.280	0.310	0.340			
		W_y	0.300	0.330	0.360			
Viewing angle	Hor.	Θ_L	—	40	—			
		Θ_R	—	40	—			
	Ver.	Φ_H	—	20	—			
		Φ_L	—	40	—			
Brightness uniformity	B_{UNI}		65	—	—	%	(5)	

3.2 Measuring Condition

- Measuring surrounding : dark room
- Lamp current $I_L = 5.0\text{mA}$, lamp freq. $f_L = 50\text{KHz}$
- Inverter : HIU-757
- $VDD=3.3\pm 0.3\text{V}$
- Surrounding temperature : $25^\circ\text{C}\pm 2^\circ\text{C}$
- 50 min. warm-up time

Document Title	HSD121PX12-A Product Information	Page No.	8 / 26
Document No.		Revision	1.0

3.3 Measuring Equipment

- Measuring equipment: LCD-7000 of Otsuka Electric Corp., which utilized MCPD-7000 for Chromaticity and BM-5A for other optical characteristics.
- Measuring spot size: 10 ~ 12 mm

Note (1) Definition of Viewing Angle:

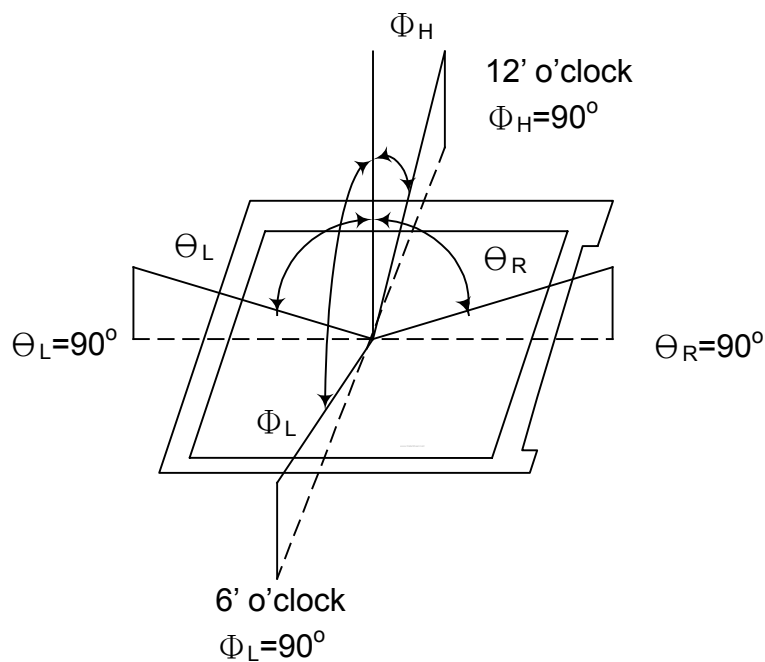

Note (2) Definition of Contrast Ratio(CR) :
measured at the center point of panel

$$CR = \frac{\text{Luminance with all pixels white (L63)}}{\text{Luminance with all pixels black (L0)}}$$

Document Title	HSD121PX12-A Product Information	Page No.	9 / 26
Document No.		Revision	1.0

Note (3) Definition of Response Time: Sum of T_R and T_F

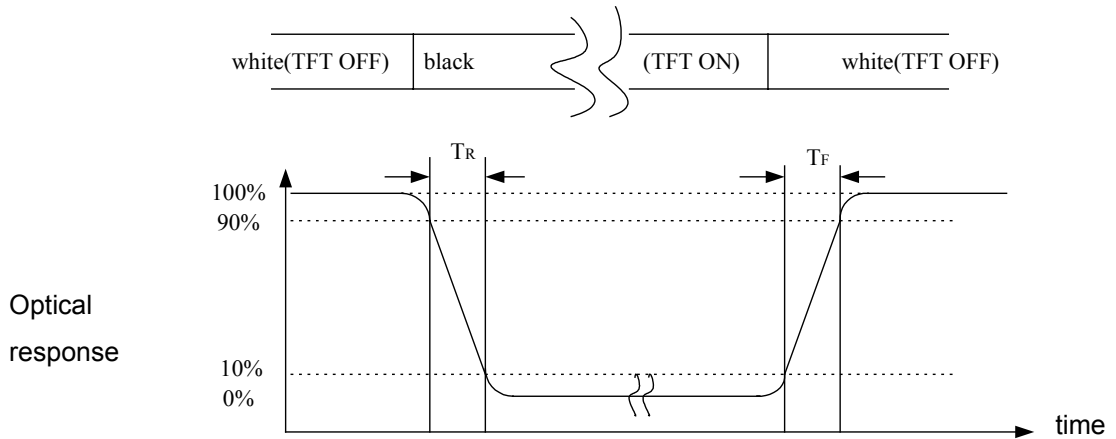

Note (4) Definition of brightness uniformity

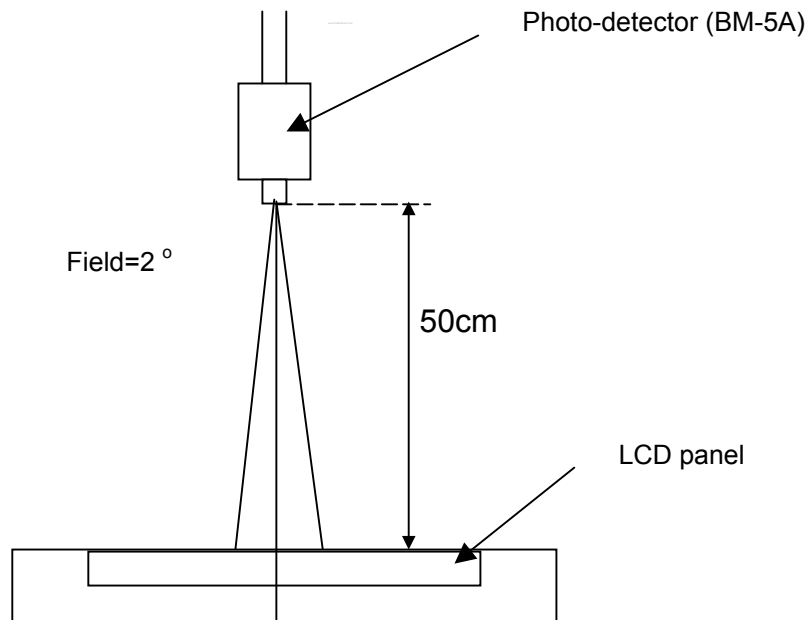

Document Title	HSD121PX12-A Product Information	Page No.	10 / 26
Document No.		Revision	1.0

Note (5) Definition of brightness uniformity

$$\text{Luminance uniformity} = (\text{Min Luminance})/(\text{Max Luminance}) \times 100\%$$

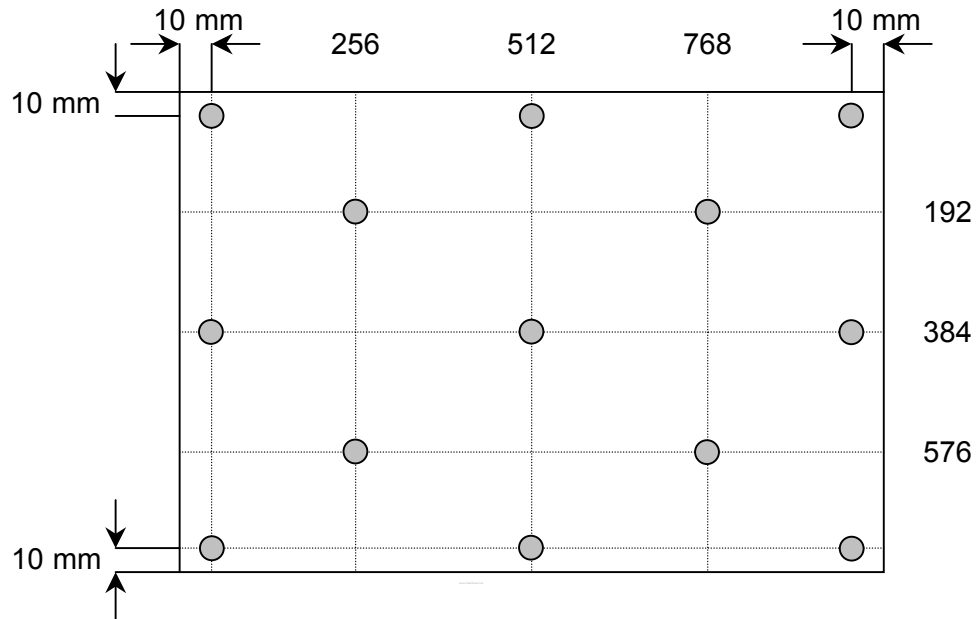

Document Title	HSD121PX12-A Product Information	Page No.	11 / 26
Document No.		Revision	1.0

4.0 OPTICAL CHARACTERISTICS

4.1 TFT LCD Module

Item	Symbol	Min.	Typ.	Max.	Unit	Note	
Voltage of power supply	V_{DD}	3.0	3.3	3.6	V		
Input voltage	High	V_{IH}	--	100	mV		
	Low	V_{IL}	-100	--	mV		
Current of power supply	Mosaic	I_{DD}	355	420	485	mA	(1)
Vsync frequency	f_V	--	60.0	--	Hz	(2)	
Hsync frequency	f_H	--	48.4	--	KHz		
Main frequency	f_{DCLK}	--	65.0	--	MHz		

Note (1) Mosaic : Dot checker image

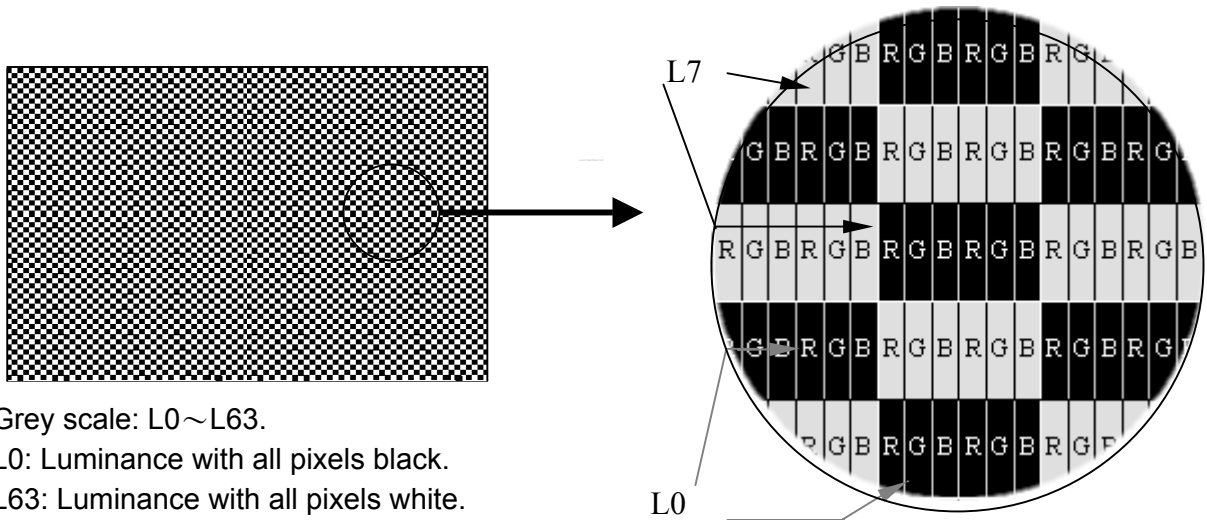

Grey scale: L0~L63.

L0: Luminance with all pixels black.

L63: Luminance with all pixels white.

Note (2) When f_V is too low, a flicker may be occurred on the display.

Document Title	HSD121PX12-A Product Information	Page No.	12 / 26
Document No.		Revision	1.0

4.2 Back-Light Unit

The back-light system is an edge-lighting type with 1 CCFL(Cold Cathode Fluorescent Lamp).The characteristics of the lamp is shown in the following tables.

Item	Symbol	Min.	Typ.	Max.	Unit	Note
Lamp current	IL	3.0	5.0	7.0	mA(rms)	(1)
Lamp voltage	VL	550	615	680	V(rms)	$I_L=6.0mA$
Frequency	fL	30	50	80	KHz	(2)
Operating life time	Hr	10,000	--	--	Hour	(3)
Startup voltage	Vs	--	--	1205	V(rms)	at 25°C
				1380		at 0°C(4)

Note (1) Lamp current is measured with current meter for high frequency as shown below. Specified valued are for a lamp.

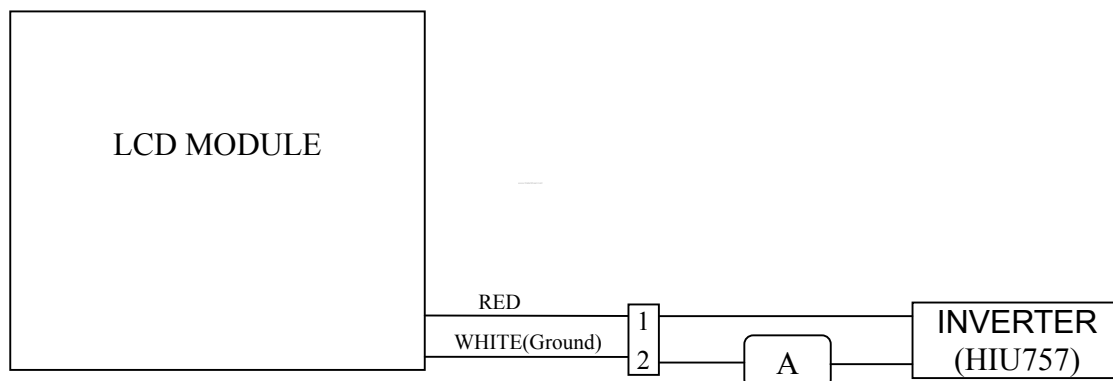

Note (2) Lamp frequency may produce interference with horizontal synchronous frequency and this may cause line flow on the display. Therefore lamp frequency shall be detached from the horizontal synchronous frequency and its harmonics as far as possible in order to avoid interference.

Note (3) Life time (Hr) can be defined as the time in which it continues to operate under the condition : $T_a=25\sim35^{\circ}C$, $I_L=5.0mA$ (Typ.) until one of the following event occurs :

1. When the brightness becomes 50%
2. When the startup voltage(V_s) at 0 °C becomes higher than the maximal Value of V_s specified above.

Note (4) Max. startup voltage shall be defined as max. voltage which CCFL can be startup.

When the customer select the inverter, the min. value of startup voltage must be higher than CCFL's max. startup voltage

Document Title	HSD121PX12-A Product Information	Page No.	13 / 26
Document No.		Revision	1.0

5.0 BLOCK DIAGRAM

5.1 TFT LCD Module

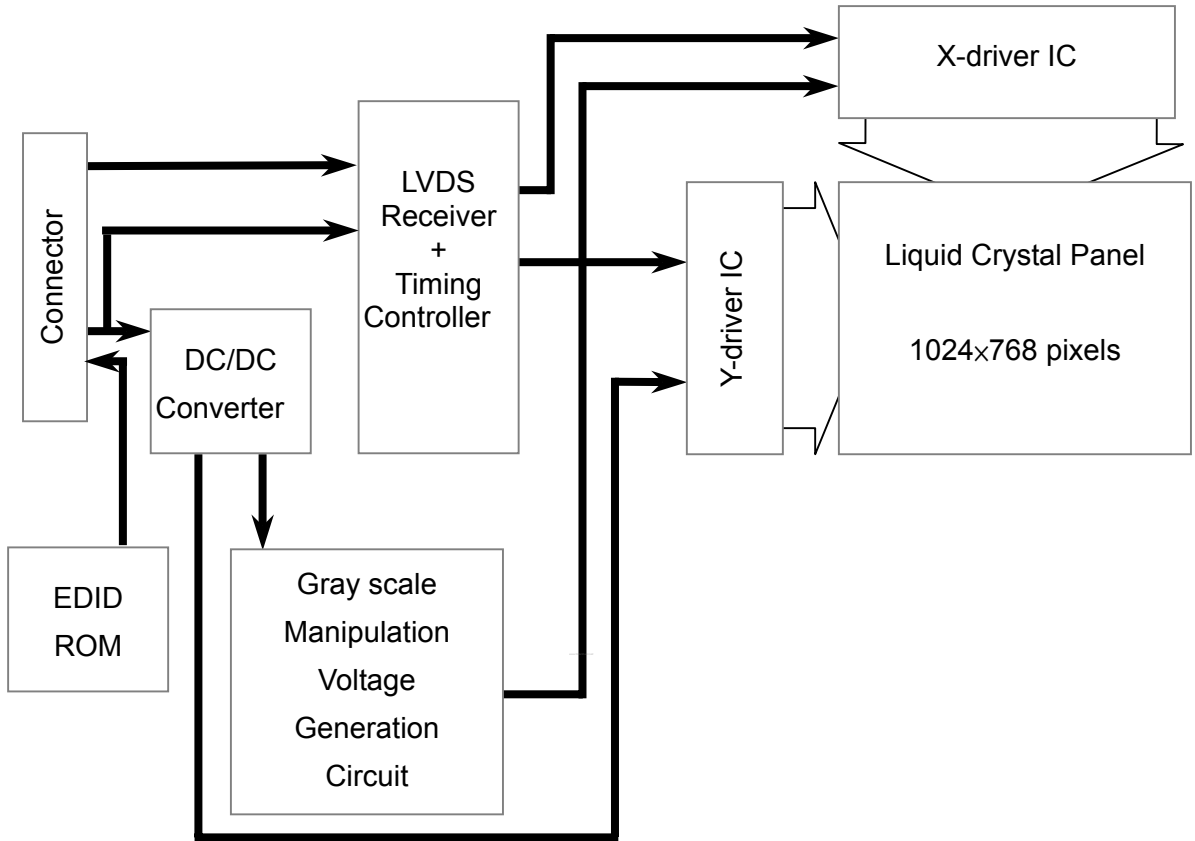

5.2 Back Light Unit

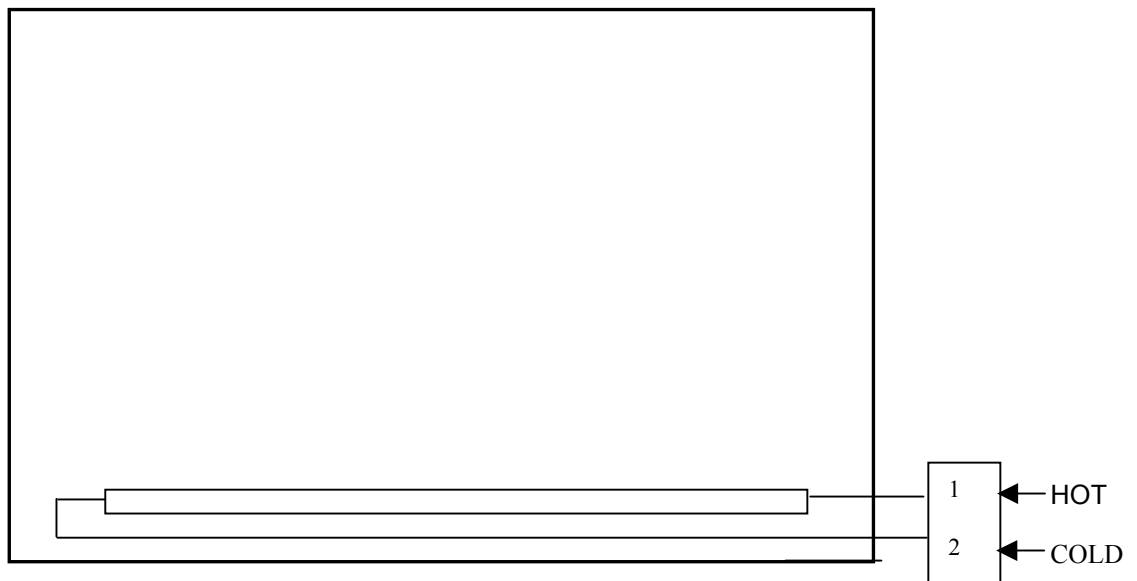

Document Title	HSD121PX12-A Product Information	Page No.	14 / 26
Document No.		Revision	1.0

6.0 INTERFACE PIN CONNECTION

6.1 TFT LCD Module

Connector : HIROSHE DF19L-20P-1H

Matching Socket : HIROSHE /Wire : DF19-20S-1C / FPC : DF19G-20S-1F

Pin No.	Symbol	Function	Polarity	Remark
1	VDD	Power Supply : +3.3V	—	
2	VDD	Power Supply : +3.3V	—	
3	GND	Ground	—	
4	GND	Ground	—	
5	IN0-	Transmission Data of Pixels 0	Negative	
6	IN0+	Transmission Data of Pixels 0	Positive	
7	GND	Ground		
8	IN1-	Transmission Data of Pixels 1	Negative	
9	IN1+	Transmission Data of Pixels 1	Positive	
10	GND	Ground		
11	IN2-	Transmission Data of Pixels 2	Negative	
12	IN2+	Transmission Data of Pixels 2	Positive	
13	GND	Ground	—	
14	CLK-	Sampling Clock	Negative	
15	CLK+	Sampling Clock	Positive	
16	GND	Ground		
17	VCC	EDID ROM Power Supply : +3.3V		
18	GND	Ground		
19	SCL	Serial CLK		
20	SDA	Serial Data/Address input/output		

6.2 Back-Light Unit

Connector : JST BHSR-02VS-1

Mating Connector : SM02B-BHSS-1

Pin No	Input	Symbol	Function
1	HOT	VL	CCFL power supply (high voltage)
2	COLD	GL	CCFL power supply (low voltage)

Document Title	HSD121PX12-A Product Information	Page No.	15 / 26
Document No.		Revision	1.0

6.3 Relationship Between Displayed Color and Input

	Display	R5	R4	R3	R2	R1	R0	G5	G4	G3	G2	G1	G0	B5	B4	B3	B2	B1	B0	Gray scale level		
Basic color	Black	L	L	L	L	L	L	L	L	L	L	L	L	L	L	L	L	L	L	-		
	Blue	L	L	L	L	L	L	L	L	L	L	L	L	H	H	H	H	H	H	-		
	Green	L	L	L	L	L	L	H	H	H	H	H	H	L	L	L	L	L	L	-		
	Light Blue	L	L	L	L	L	L	H	H	H	H	H	H	H	H	H	H	H	H	-		
	Red	H	H	H	H	H	H	L	L	L	L	L	L	L	L	L	L	L	L	-		
	Purple	H	H	H	H	H	H	L	L	L	L	L	L	H	H	H	H	H	H	-		
	Yellow	H	H	H	H	H	H	H	H	H	H	H	H	L	L	L	L	L	L	-		
	White	H	H	H	H	H	H	H	H	H	H	H	H	H	H	H	H	H	H	-		
Gray scale of Red	Black	L	L	L	L	L	L	L	L	L	L	L	L	L	L	L	L	L	L	L0		
	Dark ↑ ↓ Light	L	L	L	L	L	H	L	L	L	L	L	L	L	L	L	L	L	L	L	L1	
		L	L	L	L	H	L	L	L	L	L	L	L	L	L	L	L	L	L	L	L2	
		⋮	⋮	⋮	⋮	⋮	⋮	⋮	⋮	⋮	⋮	⋮	⋮	⋮	⋮	⋮	⋮	⋮	⋮	⋮	L3~L60	
	H	H	H	H	L	H	L	L	L	L	L	L	L	L	L	L	L	L	L	L	L61	
	H	H	H	H	H	L	L	L	L	L	L	L	L	L	L	L	L	L	L	L	L	L62
	Red	H	H	H	H	H	H	L	L	L	L	L	L	L	L	L	L	L	L	L	Red L63	
	Black	L	L	L	L	L	L	L	L	L	L	L	L	L	L	L	L	L	L	L	L0	
Gray scale of Green	Black	L	L	L	L	L	L	L	L	L	L	L	L	L	L	L	L	L	L	L	L0	
	Dark ↑ ↓ Light	L	L	L	L	L	L	L	L	L	L	L	L	H	L	L	L	L	L	L	L1	
		L	L	L	L	L	L	L	L	L	L	H	L	L	L	L	L	L	L	L	L	L2
		⋮	⋮	⋮	⋮	⋮	⋮	⋮	⋮	⋮	⋮	⋮	⋮	⋮	⋮	⋮	⋮	⋮	⋮	⋮	⋮	L3~L60
	L	L	L	L	L	L	H	H	H	H	L	H	L	L	L	L	L	L	L	L	L	L61
	L	L	L	L	L	L	H	H	H	H	H	H	L	L	L	L	L	L	L	L	L	L62
	Green	L	L	L	L	L	L	H	H	H	H	H	H	L	L	L	L	L	L	L	L	Green L63
	Black	L	L	L	L	L	L	L	L	L	L	L	L	L	L	L	L	L	L	L	L	L0
Gray scale of Blue	Black	L	L	L	L	L	L	L	L	L	L	L	L	L	L	L	L	L	L	L	L0	
	Dark ↑ ↓ Light	L	L	L	L	L	L	L	L	L	L	L	L	L	L	L	L	L	H	L	L	L1
		L	L	L	L	L	L	L	L	L	L	L	L	L	L	L	L	H	L	L	L	L2
		⋮	⋮	⋮	⋮	⋮	⋮	⋮	⋮	⋮	⋮	⋮	⋮	⋮	⋮	⋮	⋮	⋮	⋮	⋮	⋮	L3~L60
	L	L	L	L	L	L	L	L	L	L	L	L	L	H	H	H	H	L	H	L	L	L61
	L	L	L	L	L	L	L	L	L	L	L	L	L	H	H	H	H	H	L	L	L	L62
	Blue	L	L	L	L	L	L	L	L	L	L	L	L	H	H	H	H	H	H	L	L	Blue L63
	Black	L	L	L	L	L	L	L	L	L	L	L	L	L	L	L	L	L	L	L	L	L0
Gray scale of White & Black	Black	L	L	L	L	L	L	L	L	L	L	L	L	L	L	L	L	L	L	L	L	L0
	Dark ↑ ↓ Light	L	L	L	L	L	H	L	L	L	L	L	H	L	L	L	L	L	L	H	L	L1
		L	L	L	L	H	L	L	L	L	L	H	L	L	L	L	L	H	L	L	L	L2
		⋮	⋮	⋮	⋮	⋮	⋮	⋮	⋮	⋮	⋮	⋮	⋮	⋮	⋮	⋮	⋮	⋮	⋮	⋮	⋮	L3~L60
	H	H	H	H	L	H	H	H	H	L	H	H	H	H	H	H	L	H	L	L	L61	
	H	H	H	H	H	L	H	H	H	H	H	L	H	H	H	H	H	L	L	L	L	L62
	White	H	H	H	H	H	H	H	H	H	H	H	H	H	H	H	H	H	H	L	L	White L63

Document Title	HSD121PX12-A Product Information	Page No.	16 / 26
Document No.		Revision	1.0

6.4 Pixel Format

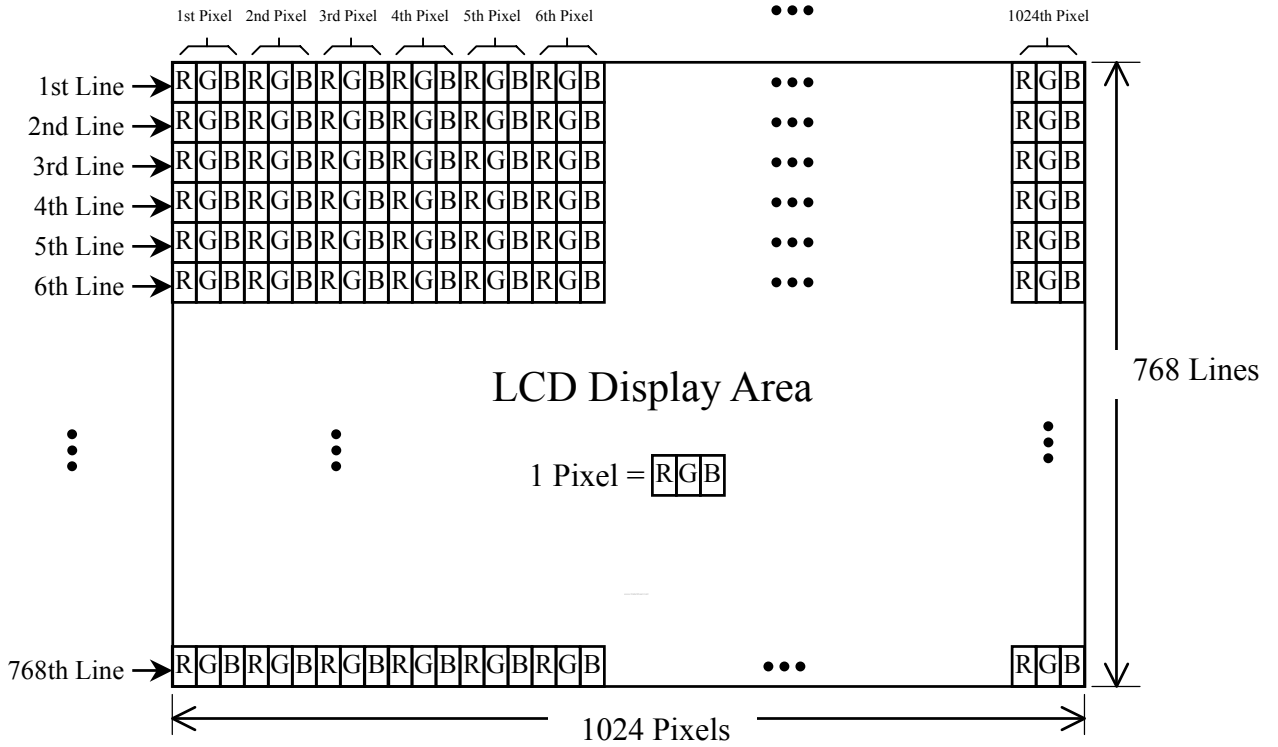

Document Title	HSD121PX12-A Product Information	Page No.	17 / 26
Document No.		Revision	1.0

6.5 Recommended Transmitter To HSD121PX12-A Interface Assignment

Case1: 6bit Transmitter

DS90CF363 or equivalent						
Input terminal no.		Input signal (Graphics controller output signal)		Output signal	HSD121PX12-A interface(CN1)	
Symbol	Terminal	Symbol	Function	Symbol	Terminal	Symbol
TIN0	44	R0	RED Pixels Display Data (LSB)	TOUT0- TOUT0+	No. 5 No. 6	IN0- IN0+
TIN1	45	R1	RED Pixels Display Data			
TIN2	47	R2	RED Pixels Display Data			
TIN3	48	R3	RED Pixels Display Data			
TIN4	1	R4	RED Pixels Display Data			
TIN5	3	R5	RED Pixels Display Data (MSB)			
TIN6	4	G0	RED Pixels Display Data (LSB)	TOUT1- TOUT1+	No. 8 No. 9	IN1- IN1+
TIN7	6	G1	GREEN Pixels Display Data			
TIN8	7	G2	GREEN Pixels Display Data			
TIN9	9	G3	GREEN Pixels Display Data			
TIN10	10	G4	GREEN Pixels Display Data			
TIN11	12	G5	GREEN Pixels Display Data (MSB)			
TIN12	13	B0	BLUE Pixels Display Data (LSB)	TOUT2- TOUT2+	No. 11 No. 12	IN2- IN2+
TIN13	15	B1	BLUE Pixels Display Data			
TIN14	16	B2	BLUE Pixels Display Data			
TIN15	18	B3	BLUE Pixels Display Data			
TIN16	19	B4	BLUE Pixels Display Data			
TIN17	20	B5	BLUE Pixels Display Data (MSB)			
TIN18	22	NC	Non Connection (open)	TOUT2+	No. 12	IN2+
TIN19	23	NC	Non Connection (open)			
TIN20	25	ENAB	Compound Synchronization Signal			
CLK IN	26	NCLK	Data Sampling Clock	TCLK OUT- TCLK OUT+	No. 14 No. 15	CLK IN- CLK IN+

Note : Please connect NC pin to nothing. Don't connect it to ground nor to other signal input.

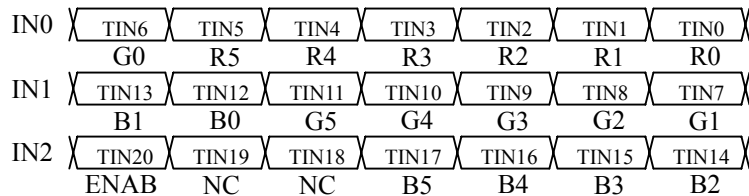

Document Title	HSD121PX12-A Product Information	Page No.	18 / 26
Document No.		Revision	1.0

Case2 : 8bit Transmitter

DS90CF383 or equivalent						
Input terminal no.		Input signal (Graphics control output signal)		Output signal	To HSD121PX12-A interface(CN1)	
Symbol	Terminal	Symbol	Function	Symbol	Terminal	Symbol
TIN0	51	R0	RED Pixels Display Data (LSB)	TOUT0-	No. 5	IN0-
TIN1	52	R1	RED Pixels Display Data			
TIN2	54	R2	RED Pixels Display Data			
TIN3	55	R3	RED Pixels Display Data			
TIN4	56	R4	RED Pixels Display Data			
TIN6	3	R5	RED Pixels Display Data (MSB)	TOUT0+	No. 6	IN0+
TIN7	4	G0	GREEN Pixels Display Data (LSB)	TOUT1-	NO.8	IN1-
TIN8	6	G1	GREEN Pixels Display Data			
TIN9	7	G2	GREEN Pixels Display Data			
TIN12	11	G3	GREEN Pixels Display Data			
TIN13	12	G4	GREEN Pixels Display Data			
TIN14	14	G5	GREEN Pixels Display Data (MSB)	TOUT1+	NO.9	IN1+
TIN15	15	B0	BLUE Pixels Display Data (LSB)	TOUT2-	NO.11	IN2-
TIN18	19	B1	BLUE Pixels Display Data			
TIN19	20	B2	BLUE Pixels Display Data			
TIN20	22	B3	BLUE Pixels Display Data			
TIN21	23	B4	BLUE Pixels Display Data			
TIN22	24	B5	BLUE Pixels Display Data (MSB)	TOUT2+	NO.12	IN2+
TIN24	27	NC	Non Connection (open)	TOUT3-		
TIN25	28	NC	Non Connection (open)			
TIN26	30	ENAB	Compound Synchronization Signal			
TIN27	50	NC	Non Connection (open)			
TIN5	2	NC	Non Connection (open)			
TIN10	8	NC	Non Connection (open)			
TIN11	10	NC	Non Connection (open)			
TIN16	16	NC	Non Connection (open)	TOUT3+		
TIN17	18	NC	Non Connection (open)			
TIN23	25	NC	Non Connection (open)			
CLK IN	31	NCLK	DATA SAMPLING CLOCK	TCLK OUT-	NO. 14	CLK IN-
				TCLK OUT+	NO. 15	CLK IN+

Note : Please connect NC pin to nothing. Don't connect it to ground nor to other signal input.

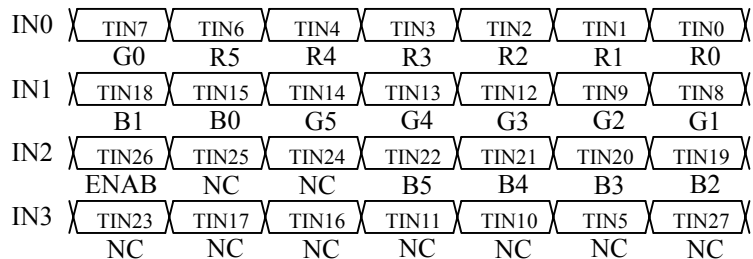

Document Title	HSD121PX12-A Product Information	Page No.	19 / 26
Document No.		Revision	1.0

7.0 INTERFACE TIMING ¹⁾²⁾³⁾⁴⁾⁵⁾⁶⁾

7.1 Timing Parameters (DE mode)

Item	Symbol	Min.	Typ.	Max.	Unit	Remarks
Frame period	t1	778×t3 —	806×t3 16.67	860×t3 —	— ms	1) 5)
Vertical display term	t2	768×t3 —	768×t3 15.88	768×t3 —	— ms	1)
One line Scanning time	t3	1180×t5 —	1344×t5 20.68	1400×t5 —	— μs	1) 5)
Horizontal display term	t4	1024×t5 —	1024×t5 15.76	1024×t5 —	— μs	1)
Clock period	t5	12.50	15.38	—	ns	5)

Note 1) Refer to 7.2 TIMING CHART and LVDS specification (DS90CF364MTD) by National Semiconductor Corporation.

Note 2) When ENAB is fixed to “H” level or “L” level after NCLK is supplied, the panel displays black with some flicker.

Note 3) If NCLK is fixed to “H” level or “L” level, for certain period while ENAB is supplied, the panel may be damaged.

Note 4) Do not make t1 and t3’s fluctuate. If t1 or t3 is fluctuate, the panel displays black.

Note 5) Please adjust LCD operating signal timing and FL driving frequency, to optimize the display quality. There is a possibility that flicker is observed by the interference of LCD operating signal timing and FL driving condition (especially driving frequency).

Note 6) All input condition(level&timing) refers to SII211 specification.

Document Title	HSD121PX12-A Product Information	Page No.	20 / 26
Document No.		Revision	1.0

7.2 Timing Diagram of Interface Signal (DE mode)

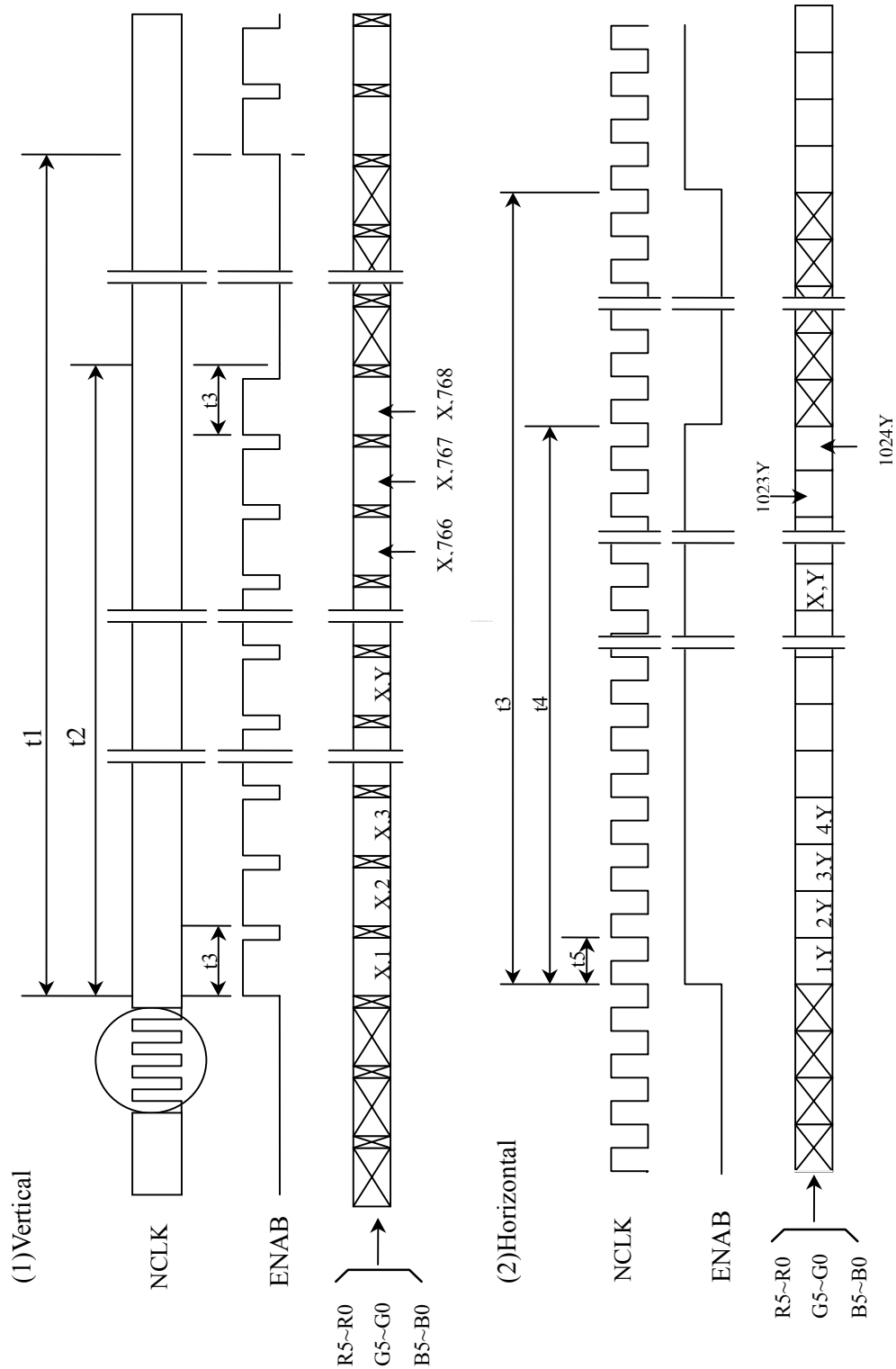

Document Title	HSD121PX12-A Product Information	Page No.	21 / 26
Document No.		Revision	1.0

7.3 Power ON/OFF Sequence

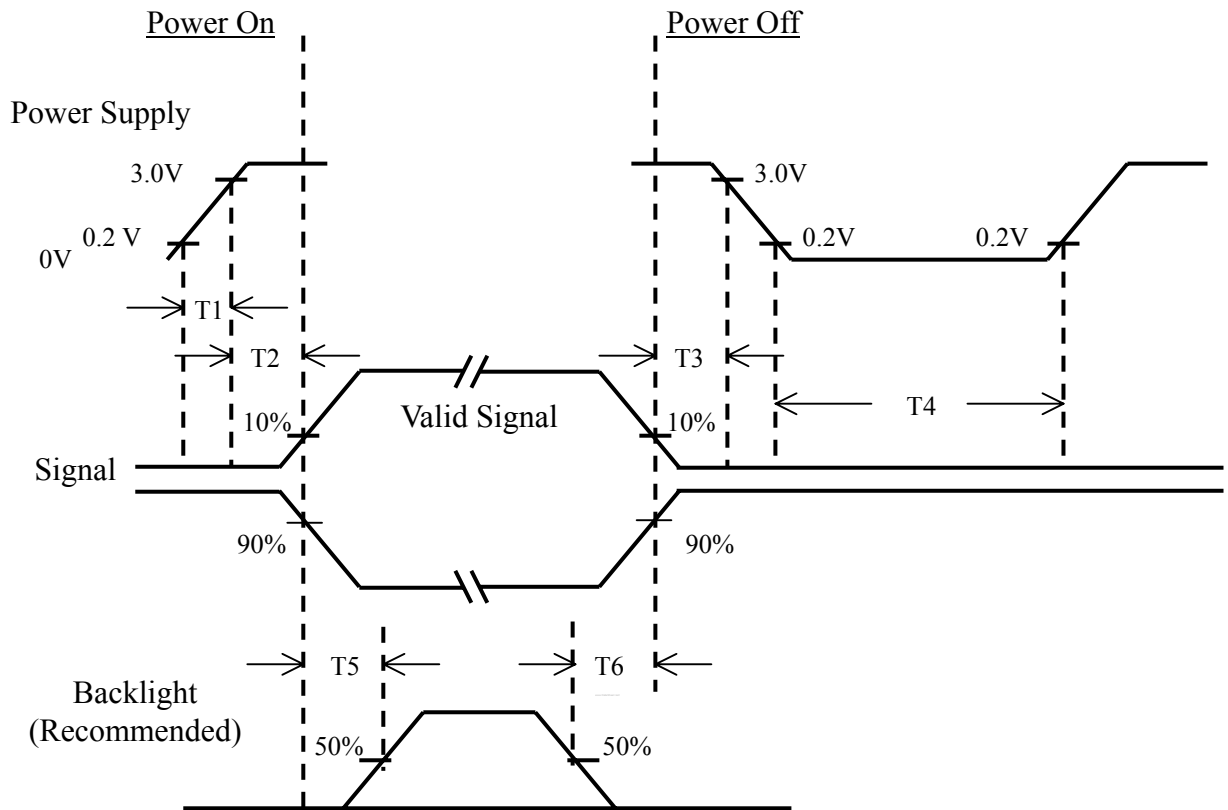

Power ON/OFF Sequence

Item	Min.	Typ.	Max.	Unit	Remark
T1	0	—	10	msec	
T2	50	—	55	msec	
T3	0	—	40	msec	
T4	500	—	—	msec	
T5	200	—	—	msec	
T6	200	—	—	msec	

- (1) The supply voltage of the external system for the module input should be the same as the definition of V_{DD} .
- (2) Apply the lamp voltage within the LCD operation range. When the back-light turns on before the LCD operation or the LCD turns off before the back-light turns off, the display may momentarily become white.
- (3) In case of $V_{DD} = \text{off level}$, please keep the level of input signal on the low or keep a high impedance.
- (4) T4 should be measured after the module has been fully discharged between power off and on period.
- (5) Interface signal shall not be kept at high impedance when the power is on.

Document Title	HSD121PX12-A Product Information	Page No.	22 / 26
Document No.		Revision	1.0

8.0 OUTLINE DIMENSION

8.1 Front View Outline Dimension

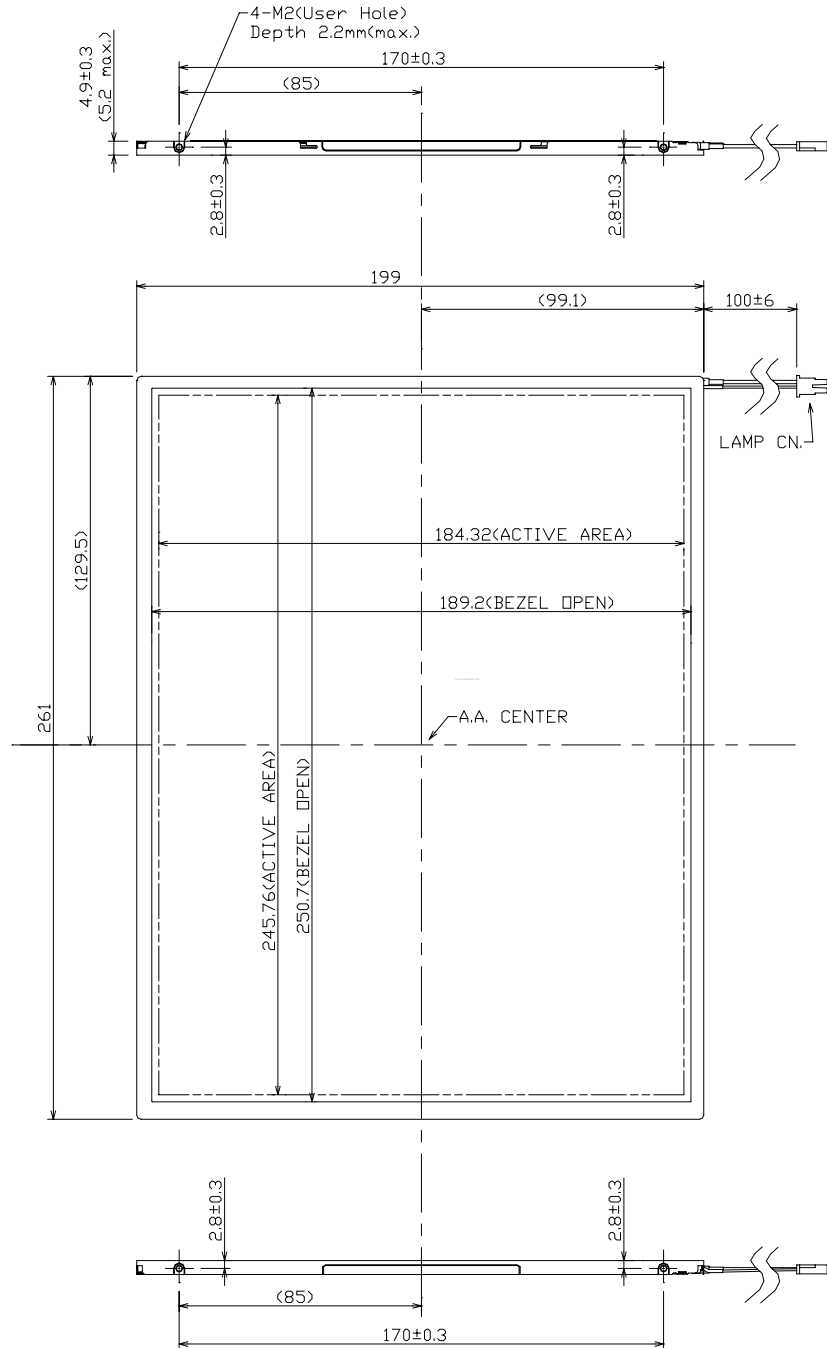

Note:

1. UNSPECIFIED DIMENSIONAL TOLERANCE ARE $\pm 0.5\text{mm}$
2. LAMP CN: BHSR-02VS-01(JST) OR COMPATIBLE CONNECTOR

Document Title	HSD121PX12-A Product Information	Page No.	23 / 26
Document No.		Revision	1.0

8.2 Back View Outline Dimension

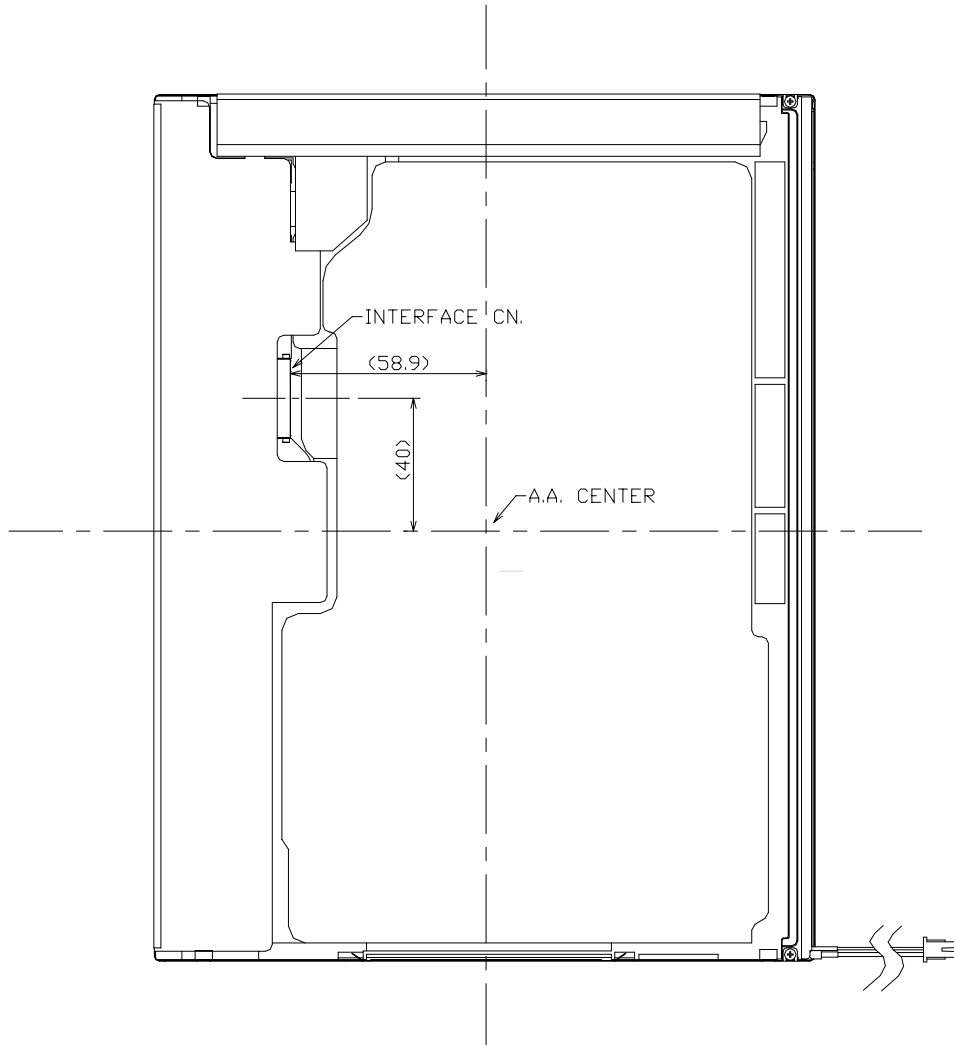

Note:
1. INTERFACE CN. : DF19L-20P-1H (HIROSE)