



HannStar Display Corp.

Document Title	HSD150PX16 Product Information	Page No.	1 / 28
Document No.		Revision	1.0

# HannStar Product Information

Model : **HSD150PX16**  
**-A01**

(A01: sub model code)

Note: 1. Please contact HannStar Display Corp. before designing your product based on this module specification.  
2. The information contained herein is presented merely to indicate the characteristics and performance of our products. No responsibility is assumed by HannStar for any intellectual property claims or other problems that may result from application based on the module described herein.



HannStar Display Corp.

Document Title	HSD150PX16 Product Information	Page No.	2 / 28
Document No.		Revision	1.0

### Record of Revisions

Rev.	Date	Description of change
1.0	Jan 10, 2004	<ul style="list-style-type: none"><li>CAS for HSD150PX16-A was first issued.</li></ul>



HannStar Display Corp.

Document Title	HSD150PX16 Product Information	Page No.	3 / 28
Document No.		Revision	1.0

## Contents

1.0	General description .....	p.4
2.0	Absolute maximum ratings .....	p.5
3.0	Optical characteristics .....	p.7
4.0	Electrical characteristics .....	p.12
5.0	Block diagram .....	p.14
6.0	Interface pin connection .....	p.15
7.0	Interface timing .....	p.20
8.0	Outline dimension .....	p.23
9.0	Package Specification.....	p.25
10.0	Lot mark .....	p.26
11.0	General precaution .....	p.27



Document Title	HSD150PX16 Product Information	Page No.	4 / 28
Document No.		Revision	1.0

## 1.0 GENERAL DESCRIPTION

### 1.1 Introduction

HannStar Display model HSD150PX16-A is a color active matrix thin film transistor (TFT) liquid crystal display(LCD) that uses amorphous silicon TFT as a switching device. This model is composed of a TFT LCD panel, a driving circuit and a back light system. This TFT LCD has a 15.0 inch diagonally measured active display area with XGA resolution (768 vertical by 1024 horizontal pixel array) and can display up to 262,144 colors.

### 1.2 Features

- 15.0 XGA for Notebook PC
- SPWG style-B standard
- 200nit High brightness

### 1.3 Applications

- Notebook PC
- Moniputers
- Display terminals for AV applications
- Monitors for industrial applications

### 1.4 General information

Item	Specification	Unit
Display area	304.128(H) x 228.096(V)	mm
Number of Pixel	1024(H) x 768(V)	pixels
Pixel pitch	0.297(H) x 0.297(V)	mm
Pixel arrangement	RGB Vertical stripe	
Display color	262,144	colors
Display mode	Normally white	
Surface treatment	Antireflection, Hard-Coating(3H)	
Weight	600	g
Back-light	Single CCFL (Side-Light type)	
Input signal	1-ch LVDS	
Optimum viewing direction	6 o'clock	

Document Title	HSD150PX16 Product Information	Page No.	5 / 28
Document No.		Revision	1.0

## 1.5 Mechanical Information

Item		Min.	Typ.	Max.	Unit
Module Size	Horizontal(H)	---	317.3	---	mm
	Vertical(V)	---	242.0	---	mm
	Depth(D)	---	---	(6.5)	mm
Weight (Without inverter)		---	600	---	g

## 2.0 ABSOLUTE MAXIMUM RATINGS

### 2.1 Absolute Rating of Environment

Item	Symbol	Min.	Max.	Unit	Note
Storage temperature	T <sub>STG</sub>	-20	60	°C	
Operating temperature	T <sub>OPR</sub>	0	50	°C	
Vibration(non-operating)	V <sub>NOP</sub>	--	1.5	G	(1)
Shock(non-operating)	S <sub>NOP</sub>	180	—	G	(2)
Storage humidity	H <sub>STG</sub>	10	90	%RH	(3)
Operating humidity	H <sub>OP</sub>	10	80	%RH	(3)
Low pressure(operating)	P <sub>LOP</sub>	697	--	hPa	(4)
Low pressure(non-operating)	P <sub>LNOP</sub>	116	--	hPa	(5)

- Note (1) 5-500Hz sweep/cycle, X, Y,Z each directions, 30min each  
 (2) 2ms, ±X, ±Y, ±Z direction, one time each. For this shock test, it is necessary to fill the silicon rubber between the shock jig as buffer.  
 (3) Max wet bulb temp.=39°C

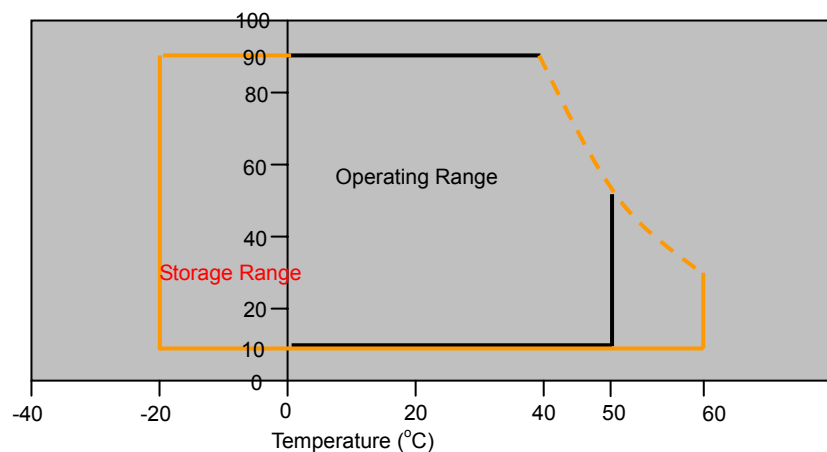

- (4) 2hrs. (10000 feet)  
 (5) 24hrs. (50000 feet)



Document Title	HSD150PX16 Product Information	Page No.	6 / 28
Document No.		Revision	1.0

## 2.2 Electrical Absolute Rating

### 2.2.1 TFT LCD Module

Item	Symbol	Min.	Max.	Unit	Note
Power supply voltage	$V_{DD}$	-0.3	4.0	V	(1)
Logic input voltage	$V_{IN}$	-0.3	$V_{DD}+0.3$	V	(1)

### 2.2.2 Back-Light Unit

Item	Symbol	Min.	Max.	Unit	Note
Lamp voltage	$V_{FL}$	0	2000	$V_{(rms)}$	(1)
Lamp current	$I_L$	--	7.0	mA	(1)
Lamp frequency	$f_L$	0	100	kHz	(1)

Note (1) Permanent damage may occur to the LCD module if beyond this specification. Functional operation should be restricted to the conditions described under normally operating conditions.



Document Title	HSD150PX16 Product Information	Page No.	7 / 28
Document No.		Revision	1.0

### 3.0 OPTICAL CHARACTERISTICS

#### 3.1 Optical specification

Item		Symbol	Condition	Min.	Typ.	Max.	Unit	Note
Contrast		CR	$\Theta=0$ $\Phi=0$ Normal viewing angle	—	250	—		(1)(2)
Response time	Rising	$T_R$		—	TR + TF = 35	-	msec	(1)(3)
	Falling	$T_F$		—		-		
White luminance (Center)		$Y_L$			—	200	—	cd/m <sup>2</sup>
Color chromaticity (CIE1931)	Red	$R_x$	Normal viewing angle	0.54	0.57	0.60		(1)(4)
		$R_y$		0.31	0.34	0.37		
	Green	$G_x$		0.29	0.32	0.35		
		$G_y$		0.54	0.57	0.60		
	Blue	$B_x$		0.12	0.15	0.18		
		$B_y$		0.11	0.14	0.17		
	White	$W_x$		0.28	0.31	0.34		
		$W_y$		0.30	0.33	0.36		
Viewing angle	Hor.	$\Theta_L$	CR>10	--	40	—		
		$\Theta_R$		--	40	—		
	Ver.	$\Theta_U$		--	20	—		
		$\Theta_D$		--	40	—		
Brightness uniformity		$B_{UNI}$	$\Theta=0$	65	—	—	%	(6)
Crosstalk		CT(n)	$\Phi=0$	—	—	1.3	%	(7)

#### 3.2 Measuring Condition

- Measuring surrounding : dark room
- Lamp current  $I_{FL}$  :  $6.0 \pm 0.1mA$ (rms), Inverter : HIU-757
- $V_{DD}=3.3V \pm 0.05V$
- Surrounding temperature :  $25 \pm 2^\circ C$
- 30min. warm-up time.

Document Title	HSD150PX16 Product Information	Page No.	8 / 28
Document No.		Revision	1.0

### 3.3 Measuring Equipment

- LCD-7000 of Otsuka Electric Corp., which utilized MCPD-7000 for Chromaticity and BM-5 for other optical characteristics.
- Measuring spot size : 10 ~ 12 mm

Note (1) Definition of Viewing Angle :

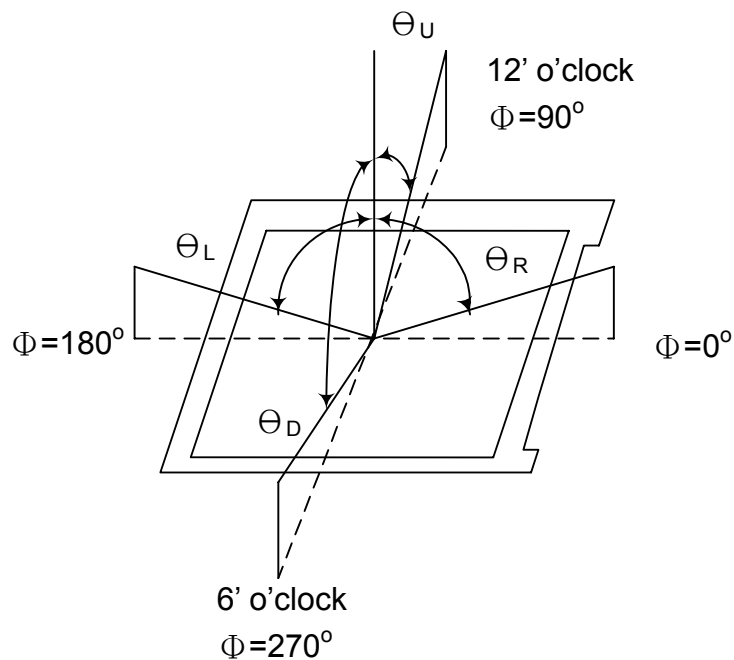

Note (2) Definition of Contrast Ratio(CR) :  
measured at the center point of panel

$$CR = \frac{\text{Luminance with all pixels white (L63)}}{\text{Luminance with all pixels black (L0)}}$$





Document Title	HSD150PX16 Product Information	Page No.	9 / 28
Document No.		Revision	1.0

Note (3) Definition of Response Time : Sum of  $T_R$  and  $T_F$

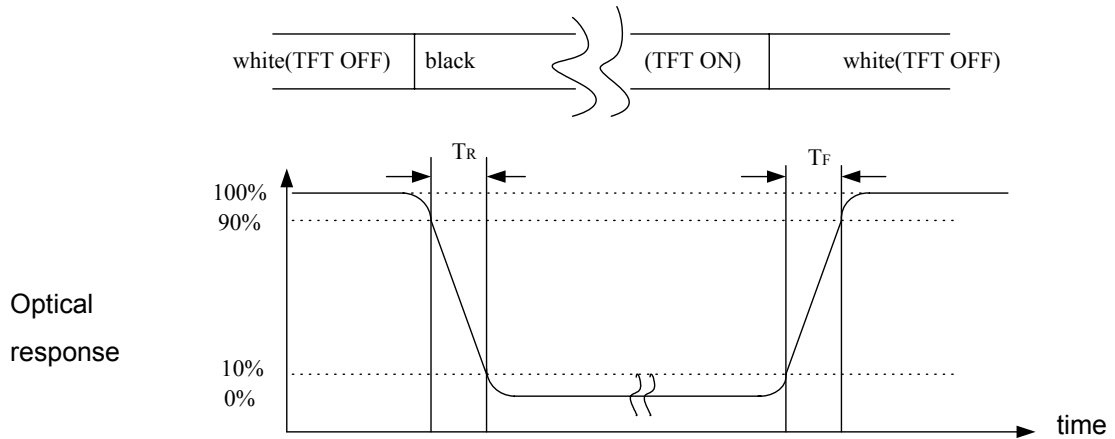

Note (4) Definition of brightness uniformity

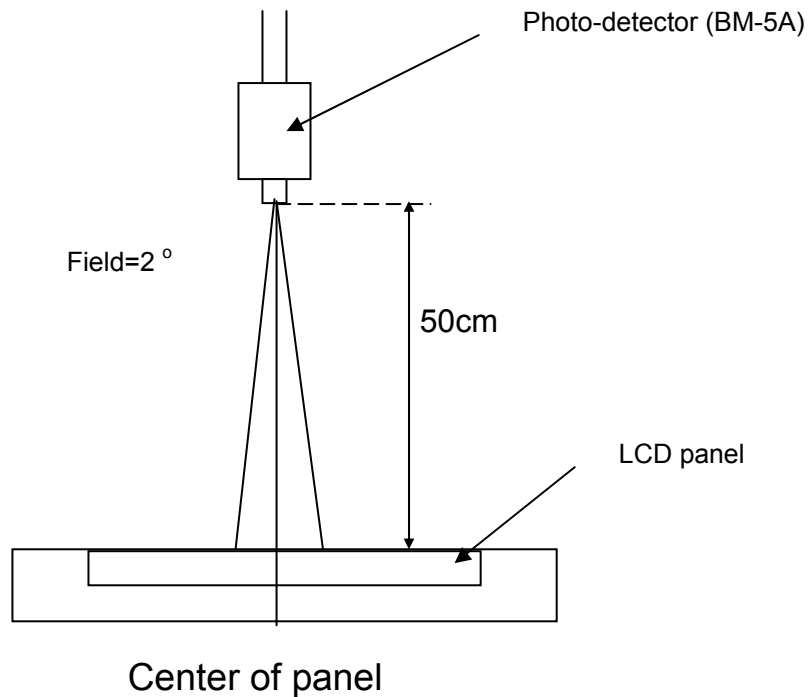



Document Title	HSD150PX16 Product Information	Page No.	10 / 28
Document No.		Revision	1.0

Note (5) Definition of White Luminance (Center):  $Y_1$

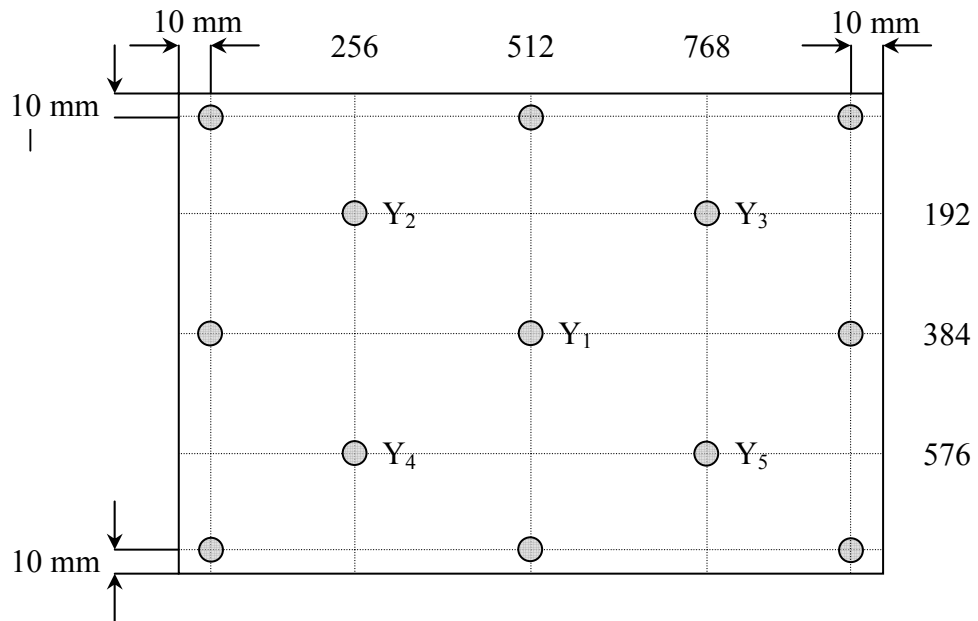

Note (6) Definition of brightness uniformity

$$\text{Luminance uniformity} = \frac{(\text{Min Luminance of 13 points})}{(\text{Max Luminance of 13 points})} \times 100\%$$

Document Title	HSD150PX16 Product Information	Page No.	11 / 28
Document No.		Revision	1.0

Note (7) Definition of crosstalk CT(1) ~ CT(4)

$$CT(n) = \frac{|L(n) - LB(n)|}{L(n)} \times 100\% , n = 1 \sim 4$$

Where L(n) = Luminance of point "n" at pattern A (cd/m<sup>2</sup>) , n=1~4

LB(n) = Luminance of point "n" at pattern B (cd/m<sup>2</sup>) , n=1~4

The location measured will be exactly the same in both patterns.

L0 : Luminance with all pixels black

L63 : Luminance with all pixels white

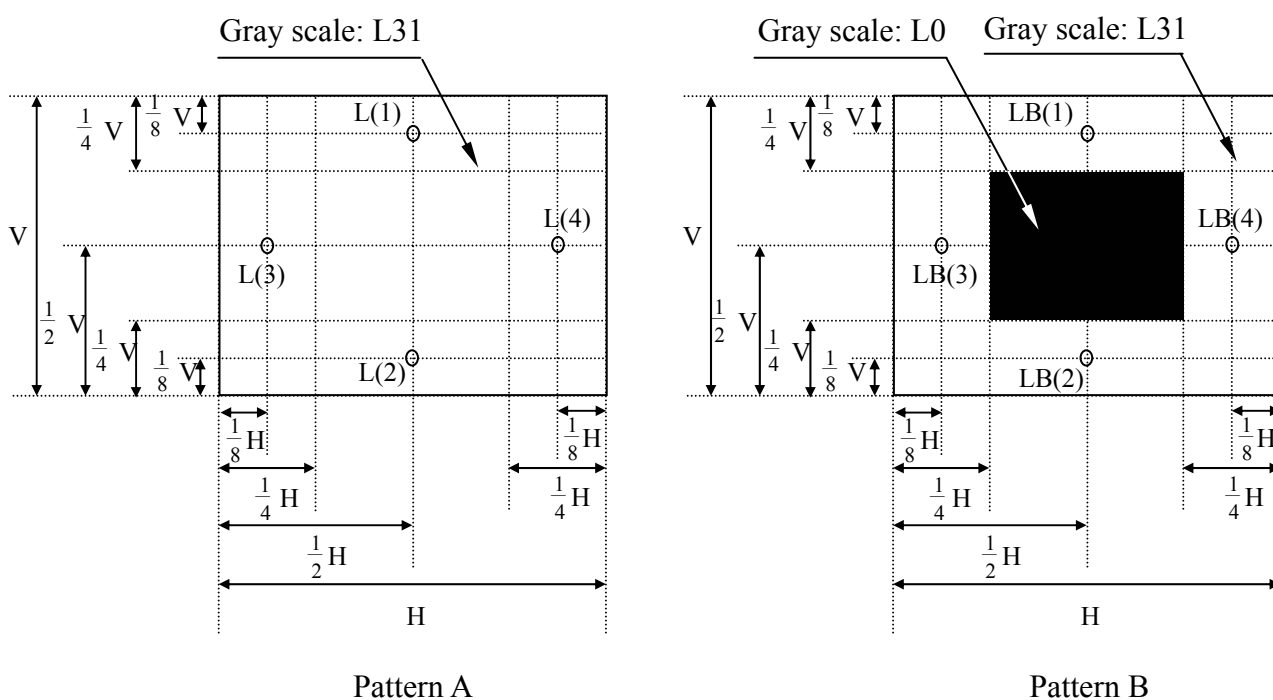

Document Title	HSD150PX16 Product Information	Page No.	12 / 28
Document No.		Revision	1.0

## 4.0 ELECTRICAL CHARACTERISTICS

### 4.1 TFT LCD Module

Item	Symbol	Min.	Typ.	Max.	Unit	Note
Voltage of power supply	$V_{DD}$	3.0	3.3	3.6	V	
Input voltage	High	$V_{IH}$	2.4	--	3.6	V
	Low	$V_{IL}$	0	--	0.9	V
Current of power supply	Mosaic	$I_{DD}$	--	(540)	--	mA (1)
Vsync frequency	$f_V$	--	60	--	Hz	(2)
Hsync frequency	$f_H$	--	48.36	--	KHz	
Frequency	$f_{DCLK}$	--	65.00	--	MHz	

Note (1) Mosaic : Dot checker image

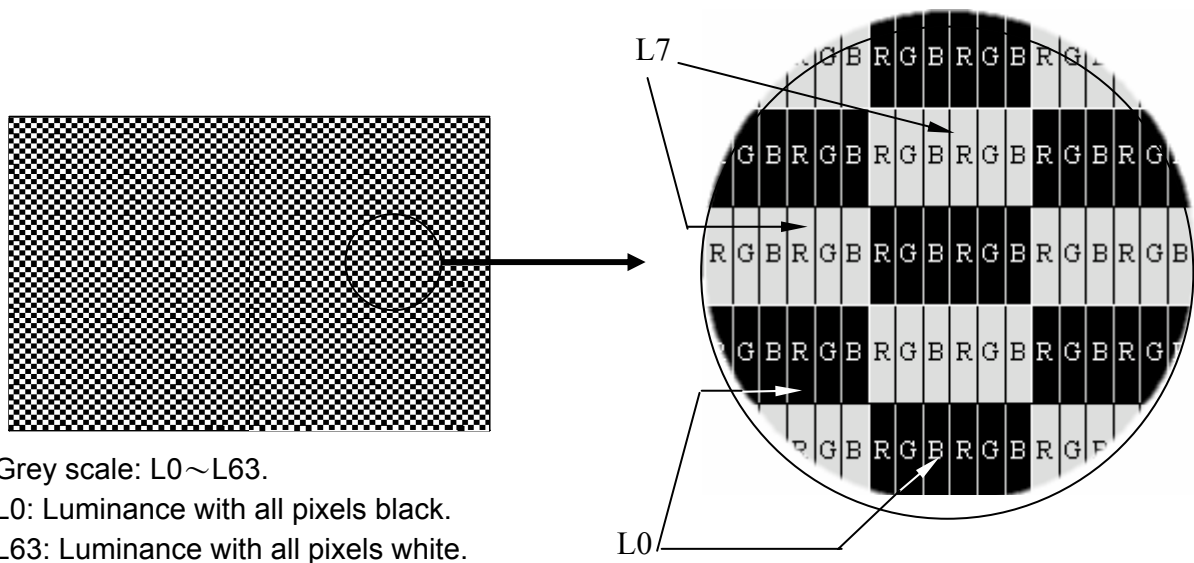

Note (2) When  $f_V$  is too low, a flicker may be occurred on the display.

Document Title	HSD150PX16 Product Information	Page No.	13 / 28
Document No.		Revision	1.0

## 4.2 Back-Light Unit

The back-light system is an edge-lighting type with 1 CCFL(Cold Cathode Fluorescent Lamp). The characteristics of the lamp is shown in the following tables.

Item	Symbol	Min.	Typ.	Max.	Unit	Note
Lamp current	IL	3.0	6.0	7.0	mA(rms)	(1)
Lamp voltage	VL		660	860	V(rms)	$I_L=6.0\text{mA}$
Frequency	fL	20	50	100	KHz	(2)
Operating life time	Hr	10,000	--	--	Hour	(3)
Startup voltage	Vs	--	--	1350	V(rms)	(4)

Note (1) Lamp current is measured with current meter for high frequency as shown below. Specified valued are for a lamp.

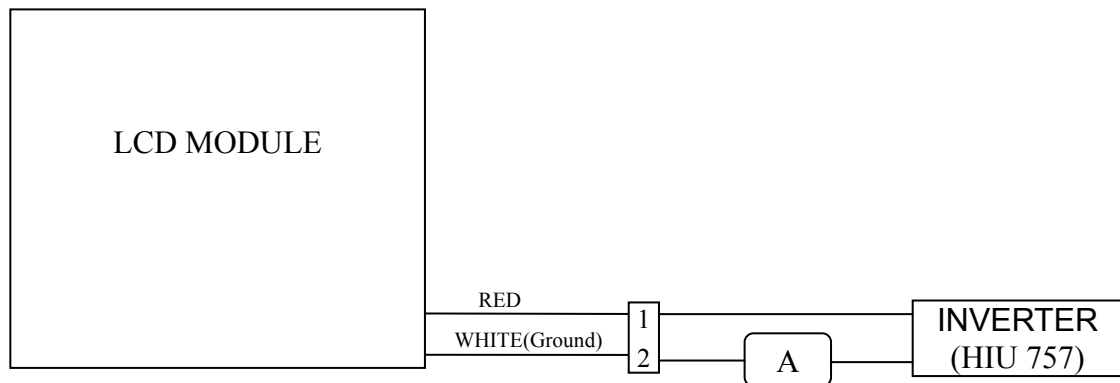

Note (2) Lamp frequency may produce interference with horizontal synchronous frequency and this may cause line flow on the display. Therefore lamp frequency shall be detached from the horizontal synchronous frequency and its harmonics as far as possible in order to avoid interference.

Note (3) Life time (Hr) can be defined as the time in which it continues to operate under the condition :  $T_a=25\pm 3^\circ\text{C}$ ,  $I_L=6.0\text{mA(rms)}$  and  $f_L=50\text{kHz}$  until one of the following event occurs :

1. When the brightness becomes 50%
2. When the startup voltage( $V_s$ ) at  $0^\circ\text{C}$  becomes higher than the maximal Value of  $V_s$  specified above.

Note (4) Max. startup voltage shall be defined as max. voltage which CCFL can be startup. When the customer select the inverter, the min. value of startup voltage must be higher than CCFL's max. startup voltage.



Document Title	HSD150PX16 Product Information	Page No.	14 / 28
Document No.		Revision	1.0

**5.0 BLOCK DIAGRAM**  
**5.1 TFT LCD Module**

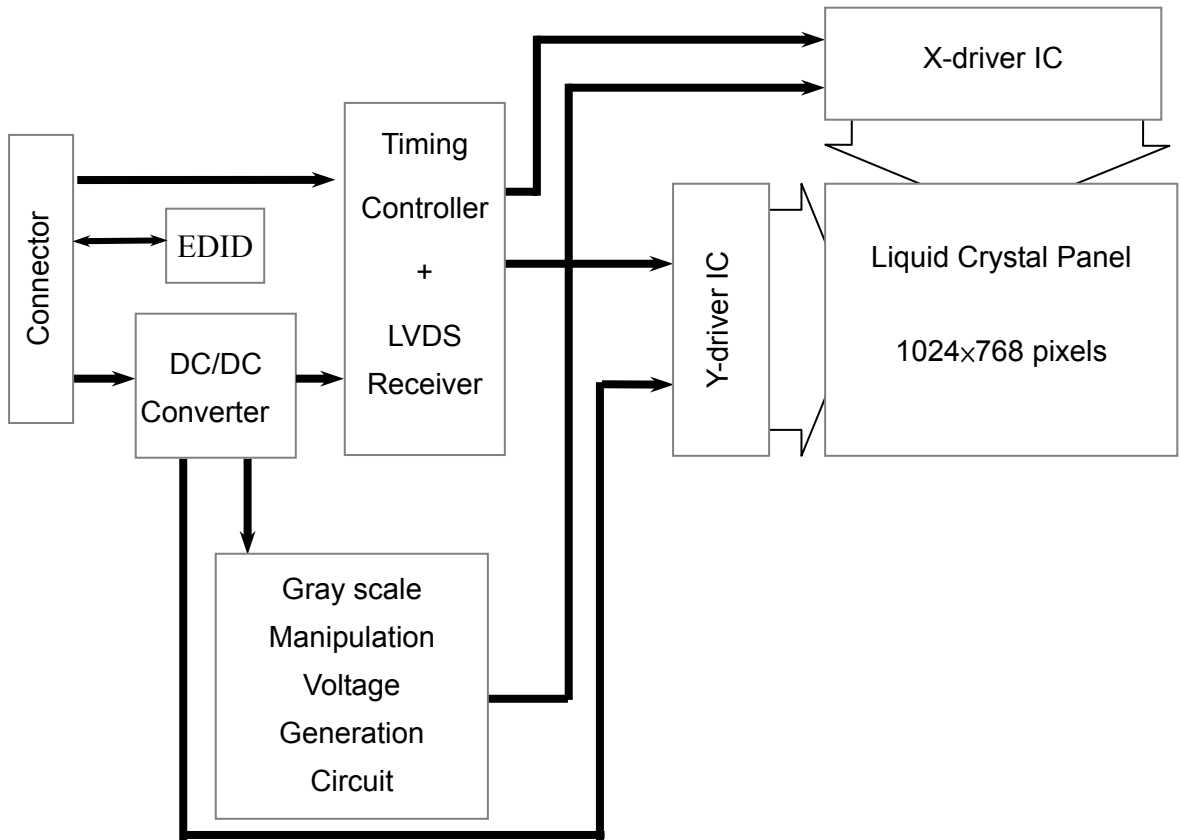

**5.2 Back Light Unit**

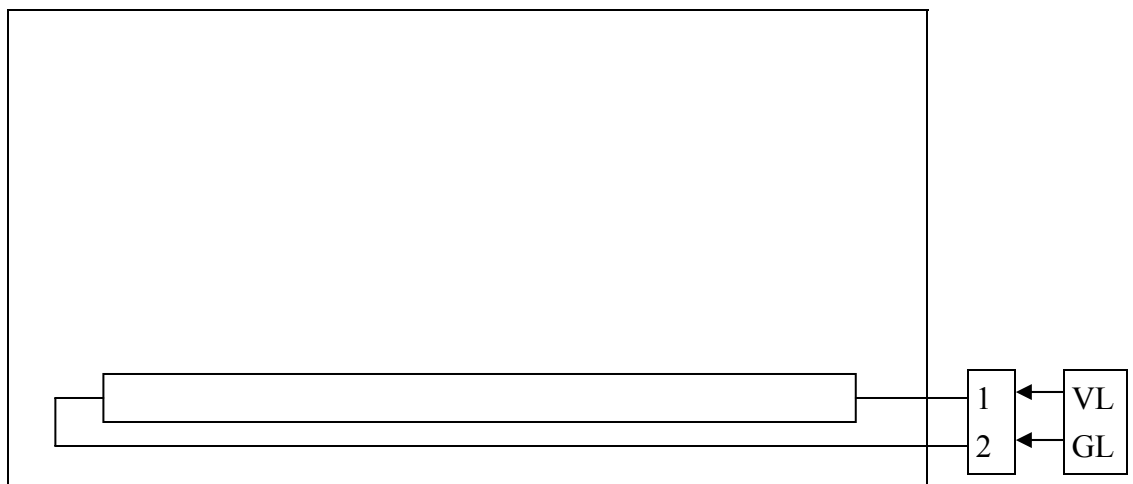



Document Title	HSD150PX16 Product Information	Page No.	15 / 28
Document No.		Revision	1.0

## 6.0 INTERFACE PIN CONNECTION

### 6.1 TFT LCD Module

N1<sup>1)</sup> INPUT SIGNAL (FI-XB30S-HF10 /JAPAN AVIATION ELECTRONICS INDUSTRY,LTD.)<sup>1)</sup>

MATING CONNECTOR: FI-X30M,FI-X30MR

Terminal no.	Symbol	Function
1	GND	Ground
2	VDD	Power Supply : +3.3V
3	VDD	Power Supply : +3.3V
4	VEDID	DDC 3.3V power
5	NC	Reserved for supplier test point
6	ClkEDID	DDC clock
7	DATAEDID	DDC data
8	IN0-	Transmission Data of Pixels 0 (Negative : -)
9	IN0+	Transmission Data of Pixels 0 (Positive : +)
10	GND	Ground
11	IN1-	Transmission Data of Pixels 1 (Negative : -)
12	IN1+	Transmission Data of Pixels 1 (Positive : +)
13	GND	Ground
14	IN2-	Transmission Data of Pixels 2 (Negative : -)
15	IN2+	Transmission Data of Pixels 2 (Positive : +)
16	GND	Ground
17	CLK-	Sample Clock (Negative : -)
18	CLK+	Sample Clock (Positive : +)
19	GND	Ground
20	NC	Reserved for supplier test point
21	NC	Reserved for supplier test point
22	GND	Ground
23	NC	Reserved for supplier test point
24	NC	Reserved for supplier test point
25	GND	Ground
26	NC	Reserved for supplier test point
27	NC	Reserved for supplier test point
28	GND	Ground
29	NC	Reserved for supplier test point
30	NC	Reserved for supplier test point

Note 1) Please connects NC pin to nothing. Don't connect it to ground nor to other signal input.  
(NC pin should be open.)

### 6.2 Back-Light Unit

CN2 CCFL Power Source (**BHSR-02VS-1**) / JAPAN SOLDERLESS TERMINAL MFG CO., LTD.

Mating Connector: (**SBHT-002T-P0.5**) / JAPAN SOLDERLESS TERMINAL MFG CO., LTD.

Terminal no.	Symbol	Function
1	V <sub>L</sub>	CCFL power supply (high voltage)
2	G <sub>L</sub>	CCFL power supply (low voltage)



Document Title	HSD150PX16 Product Information	Page No.	16 / 28
Document No.		Revision	1.0

### 6.3 Relationship Between Displayed Color and Input

	Display	MSB						LSB						MSB						LSB						Gray scale level
		R5	R4	R3	R2	R1	R0	G5	G4	G3	G2	G1	G0	B5	B4	B3	B2	B1	B0							
Basic color	Black	L	L	L	L	L	L	L	L	L	L	L	L	L	L	L	L	L	L	-						
	Blue	L	L	L	L	L	L	L	L	L	L	L	L	H	H	H	H	H	H	-						
	Green	L	L	L	L	L	L	H	H	H	H	H	H	L	L	L	L	L	L	-						
	Light Blue	L	L	L	L	L	L	H	H	H	H	H	H	H	H	H	H	H	H	-						
	Red	H	H	H	H	H	H	L	L	L	L	L	L	L	L	L	L	L	L	-						
	Purple	H	H	H	H	H	H	L	L	L	L	L	L	H	H	H	H	H	H	-						
	Yellow	H	H	H	H	H	H	H	H	H	H	H	H	L	L	L	L	L	L	-						
White	H	H	H	H	H	H	H	H	H	H	H	H	H	H	H	H	H	H	-							
Gray scale of Red	Black	L	L	L	L	L	L	L	L	L	L	L	L	L	L	L	L	L	L	L0						
	Dark ↑ ↓ Light	L	L	L	L	L	H	L	L	L	L	L	L	L	L	L	L	L	L	L1						
		L	L	L	L	H	L	L	L	L	L	L	L	L	L	L	L	L	L	L2						
		:	:	:	:	:	:	:	:	:	:	:	:	:	:	:	:	:	:	L3...L60						
		H	H	H	H	L	H	L	L	L	L	L	L	L	L	L	L	L	L	L61						
		H	H	H	H	H	L	L	L	L	L	L	L	L	L	L	L	L	L	L62						
	Red	H	H	H	H	H	H	L	L	L	L	L	L	L	L	L	L	L	L	Red L63						
Gray scale of Green	Black	L	L	L	L	L	L	L	L	L	L	L	L	L	L	L	L	L	L	L0						
	Dark ↑ ↓ Light	L	L	L	L	L	L	L	L	L	L	L	H	L	L	L	L	L	L	L1						
		L	L	L	L	L	L	L	L	L	L	L	H	L	L	L	L	L	L	L2						
		:	:	:	:	:	:	:	:	:	:	:	:	:	:	:	:	:	:	L3...L60						
		L	L	L	L	L	L	H	H	H	H	L	H	L	L	L	L	L	L	L61						
		L	L	L	L	L	L	H	H	H	H	H	L	L	L	L	L	L	L	L62						
	Green	L	L	L	L	L	L	H	H	H	H	H	H	L	L	L	L	L	L	Green L63						
Gray scale of Blue	Black	L	L	L	L	L	L	L	L	L	L	L	L	L	L	L	L	L	L	L0						
	Dark ↑ ↓ Light	L	L	L	L	L	L	L	L	L	L	L	L	L	L	L	L	L	H	L1						
		L	L	L	L	L	L	L	L	L	L	L	L	L	L	L	L	H	L	L2						
		:	:	:	:	:	:	:	:	:	:	:	:	:	:	:	:	:	:	L3...L60						
		L	L	L	L	L	L	L	L	L	L	L	L	H	H	H	H	L	H	L61						
		L	L	L	L	L	L	L	L	L	L	L	L	H	H	H	H	H	L	L62						
	Blue	L	L	L	L	L	L	L	L	L	L	L	L	H	H	H	H	H	H	Blue L63						
Gray scale of White & Black	Black	L	L	L	L	L	L	L	L	L	L	L	L	L	L	L	L	L	L	L0						
	Dark ↑ ↓ Light	L	L	L	L	L	H	L	L	L	L	L	H	L	L	L	L	L	H	L1						
		L	L	L	L	H	L	L	L	L	L	H	L	L	L	L	L	H	L	L2						
		:	:	:	:	:	:	:	:	:	:	:	:	:	:	:	:	:	:	L3...L60						
		H	H	H	H	L	H	H	H	H	H	L	H	H	H	H	H	L	H	L61						
		H	H	H	H	H	L	H	H	H	H	H	L	H	H	H	H	H	L	L62						
	White	H	H	H	H	H	H	H	H	H	H	H	H	H	H	H	H	H	H	White L63						





Document Title	HSD150PX16 Product Information	Page No.	17 / 28
Document No.		Revision	1.0

### 6.4 Pixel Format

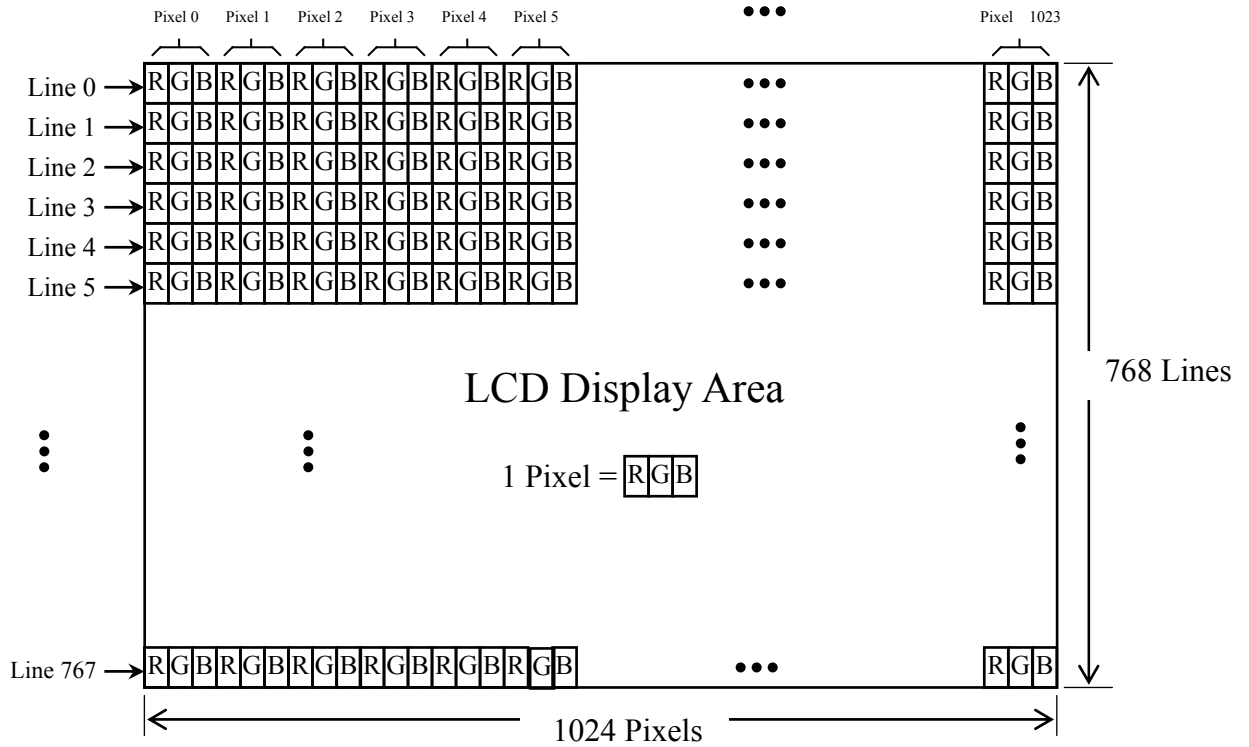



Document Title	HSD150PX16 Product Information	Page No.	18 / 28
Document No.		Revision	1.0

### 6.5 RECOMMENDED TRANSMITTER TO HSD150PX16-A INTERFACE ASSIGNMENT

#### Case1: DATA (6bit transmitter)

DS90CF363				Output Signal Symbol	LTM15C425S Interface (CN1)	
Input Terminal No.		Input Signal (Graphics controller output signal)			Terminal	Symbol
Symbol	Terminal	Symbol	Function			
TIN0	44	R0	Red Pixels Display Data (LSB)	TOUT0- TOUT0+	No.8 No.9	IN0- IN0+
TIN1	45	R1	Red Pixels Display Data			
TIN2	47	R2	Red Pixels Display Data			
TIN3	48	R3	Red Pixels Display Data			
TIN4	1	R4	Red Pixels Display Data			
TIN5	3	R5	Red Pixels Display Data (MSB)	TOUT1- TOUT1+	No.11 No.12	IN1- IN1+
TIN6	4	G0	Green Pixels Display Data (LSB)			
TIN7	6	G1	Green Pixels Display Data			
TIN8	7	G2	Green Pixels Display Data			
TIN9	9	G3	Green Pixels Display Data			
TIN10	10	G4	Green Pixels Display Data	TOUT2- TOUT2+	No.14 No.15	IN2- IN2+
TIN11	12	G5	Green Pixels Display Data (MSB)			
TIN12	13	B0	Blue Pixels Display Data (LSB)			
TIN13	15	B1	Blue Pixels Display Data			
TIN14	16	B2	Blue Pixels Display Data			
TIN15	18	B3	Blue Pixels Display Data	TCLK OUT- TCLK OUT+	No.17 No.18	CLK- CLK+
TIN16	19	B4	Blue Pixels Display Data			
TIN17	20	B5	Blue Pixels Display Data (MSB)			
TIN18	22	NC	Non Connection (open)			
TIN19	23	NC	Non Connection (open)			
TIN20	25	ENAB	Compound Synchronization Signal			
CLK IN	26	NCLK	Data Sampling Clock			

Note : Please connect NC pin to nothing. Don't connect it to ground nor to other signal input.

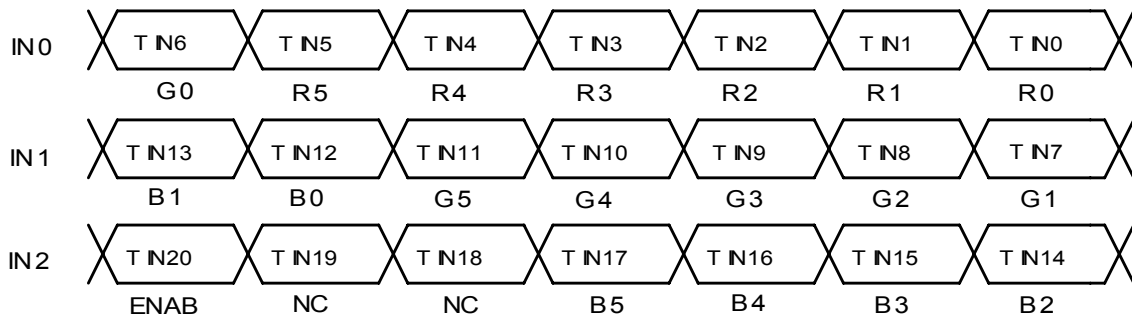



Document Title	HSD150PX16 Product Information	Page No.	19 / 28
Document No.		Revision	1.0

**Case2 : DATA (8bit transmitter)**

DS90CF383				LTM15C425S Interface (CN1)		
Input Terminal No.		Input Signal (Graphics controller output signal)		Output Signal Symbol	Terminal	Symbol
Symbol	Terminal	Symbol	Function			
TIN0	51	R0	Red Pixels Display Data (LSB)	TOUT0- TOUT0+	No.8 No.9	IN0- IN0+
TIN1	52	R1	Red Pixels Display Data			
TIN2	54	R2	Red Pixels Display Data			
TIN3	55	R3	Red Pixels Display Data			
TIN4	56	R4	Red Pixels Display Data			
TIN6	3	R5	Red Pixels Display Data (MSB)	TOUT1- TOUT1+	No.11 No.12	IN1- IN1+
TIN7	4	G0	Green Pixels Display Data(LSB)			
TIN8	6	G1	Green Pixels Display Data			
TIN9	7	G2	Green Pixels Display Data			
TIN12	11	G3	Green Pixels Display Data			
TIN13	12	G4	Green Pixels Display Data	TOUT2- TOUT2+	No.14 No.15	IN2- IN2+
TIN14	14	G5	Green Pixels Display Data(MSB)			
TIN15	15	B0	Blue Pixels Display Data (LSB)			
TIN18	19	B1	Blue Pixels Display Data			
TIN19	20	B2	Blue Pixels Display Data			
TIN20	22	B3	Blue Pixels Display Data	TOUT3- TOUT3+	---	---
TIN21	23	B4	Blue Pixels Display Data			
TIN22	24	B5	Blue Pixels Display Data (MSB)			
TIN24	27	NC	Non Connection (open)			
TIN25	28	NC	Non Connection (open)			
TIN26	30	ENAB	Compound Synchronization Signal	TCLK OUT- TCLK OUT+	No.17 No.18	CLK- CLK+
TIN27	50	NC	Non Connection (open)			
TIN5	2	NC	Non Connection (open)			
TIN10	8	NC	Non Connection (open)			
TIN11	10	NC	Non Connection (open)			
TIN16	16	NC	Non Connection (open)			
TIN17	18	NC	Non Connection (open)			
TIN23	25	NC	Non Connection (open)			
CLK IN	31	NCLK	Data Sampling Clock			

Note : Please connect NC pin to nothing. Don't connect it to ground nor to other signal input.

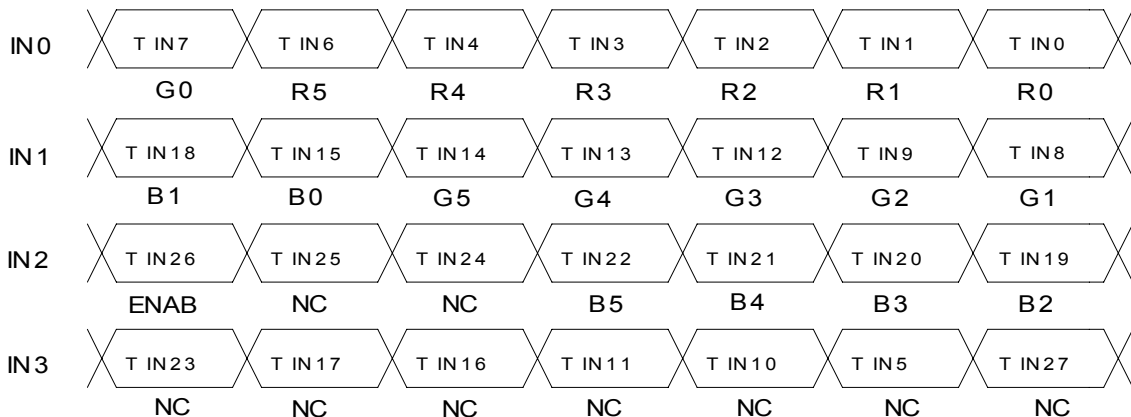



Document Title	HSD150PX16 Product Information	Page No.	20 / 28
Document No.		Revision	1.0

## 7.0 INTERFACE TIMING <sup>1)2)3)4)5)6)</sup>

### 7.1 Timing Parameters ( DE mode)

Item		Symbol	Min.	Typ.	Max.	Unit	Remarks
Vertical display term	Period	t1	778×t4 —	806×t4 16.67	860×t4 —	— ms	<sup>1) 5)</sup>
	Active	t2	—	768×t4 15.88	—	— ms	<sup>1)</sup>
	Display start	t3	4×t4 —	—	—	— ms	<sup>1)</sup>
Horizontal display term	Period	t4	1180×t7 —	1344×t7 20.68	1400×t7 —	— μs	<sup>1) 5)</sup>
	Active	t5	—	1024×t7 15.76	—	— μs	<sup>1)</sup>
	Display Start	t6	32×t7 —	—	—	— μs	<sup>1)</sup>
Clock	Period	t7	12.50	15.38	—	ns	<sup>5)</sup>
	Low time	t8	5	—	—	ns	
	High time	t9	5	—	—	ns	
Data	Setup time	t10	2	—	—	ns	
	Hold time	t11	5	—	—	ns	

Note 1) Refer to TIMING CHART at Chapter 7.2.

Note 2) In case of using the long frame period, the deterioration of display quality, noise etc. may be occurred.

Note 3) When ENAB is fixed to “L” level after NCLK input, the panel is displayed as black. However, a flicker may be occurred on the display. When ENAB is fixed to “H” level after NCLK input, the panel will be damaged.

Note 4) Do not fix NCLK to “H” or “L” level while the  $V_{DD}$  (+3.3V) is supplied. If NCLK is fixed to “H” level or “L” level for certain period while the  $V_{DD}$  (+3.3V) is supplied, the panel may be damaged.

Note 5) Do not change t1 and t4 values in the operation. When t1 or t4 is changed, the panel is displayed as black.

Note 6) Please adjust LCD operating signal timing and FL driving frequency, to optimize the display quality. There is a possibility that flicker is observed by the interference of LCD operating signal timing and FL driving condition (especially driving frequency).

Document Title	HSD150PX16 Product Information	Page No.	21 / 28
Document No.		Revision	1.0

### 7.2 Timing Chart

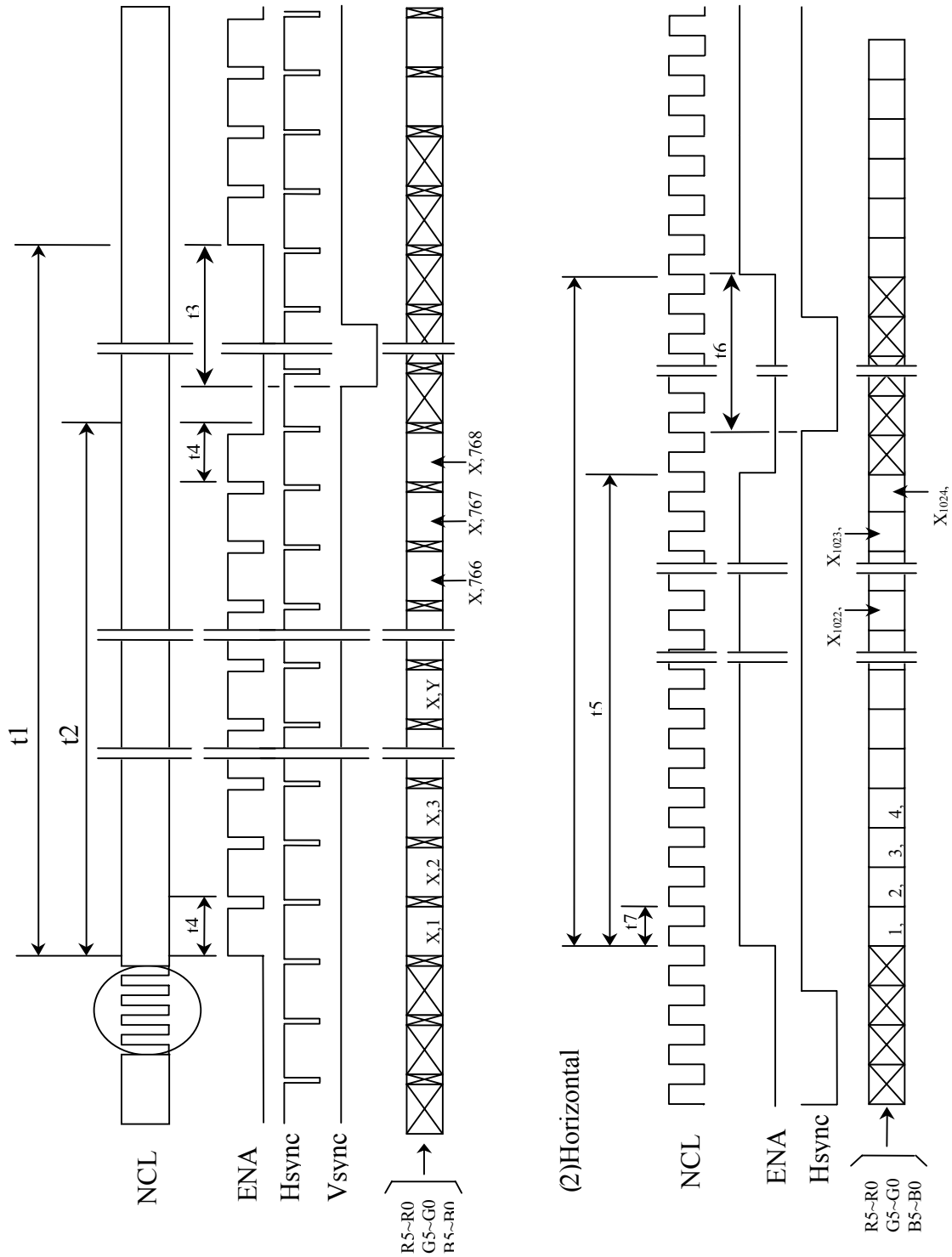

Document Title	HSD150PX16 Product Information	Page No.	22 / 28
Document No.		Revision	1.0

### 7.3 Power ON/OFF Sequence

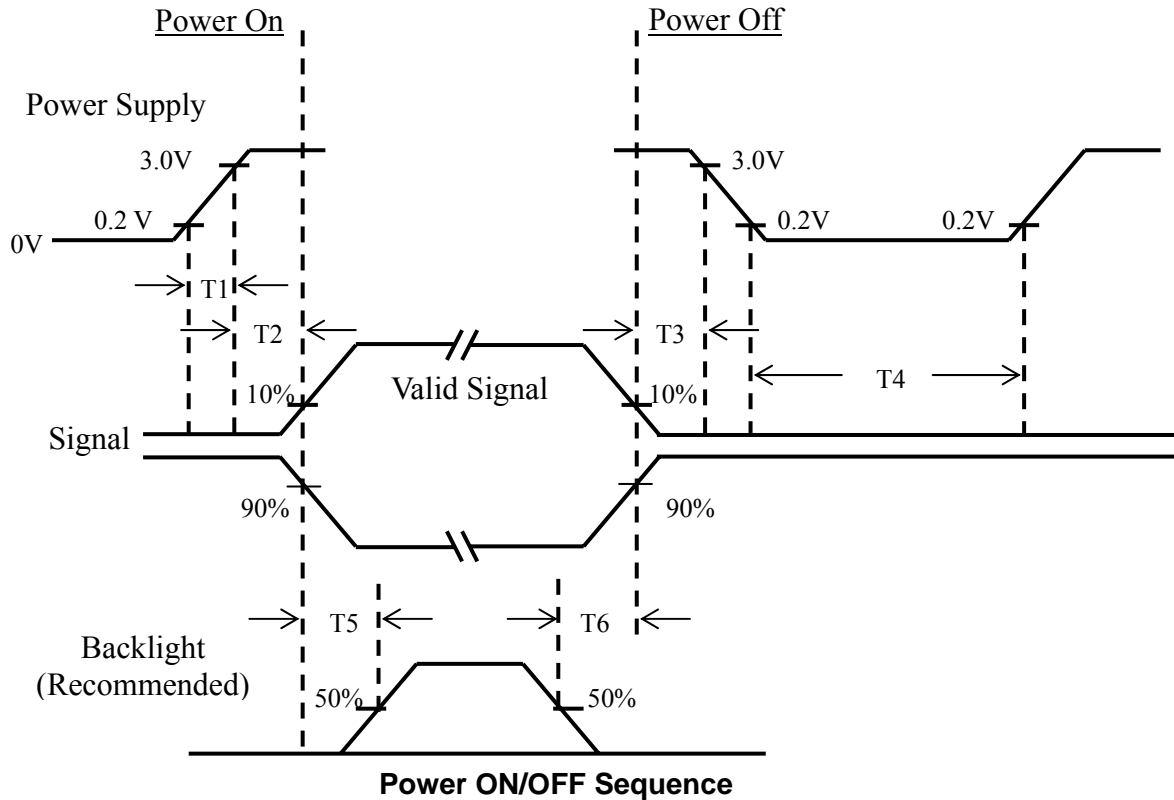

Item	Min.	Typ.	Max.	Unit	Remark
T1	0.47	—	10	msec	
T2	0	—	50	msec	
T3	0	—	50	msec	
T4	400	—	—	msec	
T5	200	—	—	msec	
T6	200	—	—	msec	

Note (1) The supply voltage of the external system for the module input should be the same as the definition of  $V_{DD}$ .

(2) Apply the lamp voltage within the LCD operation range. When the back-light turns on before the LCD operation or the LCD turns off before the back-light turns off, the display may momentarily become white.

(3) In case of  $V_{DD}$  = off level, please keep the level of input signal on the low or keep a high impedance.

(4) T4 should be measured after the module has been fully discharged between power off and on period.

(5) Interface signal shall not be kept at high impedance when the power is on.



Document Title	HSD150PX16 Product Information	Page No.	23 / 28
Document No.		Revision	1.0

## 8.0 OUTLINE DIMENSION

Unit : mm

### 8.1 Front View Outline Dimension

The unspecified tolerance is  $\pm 0.5\text{mm}$

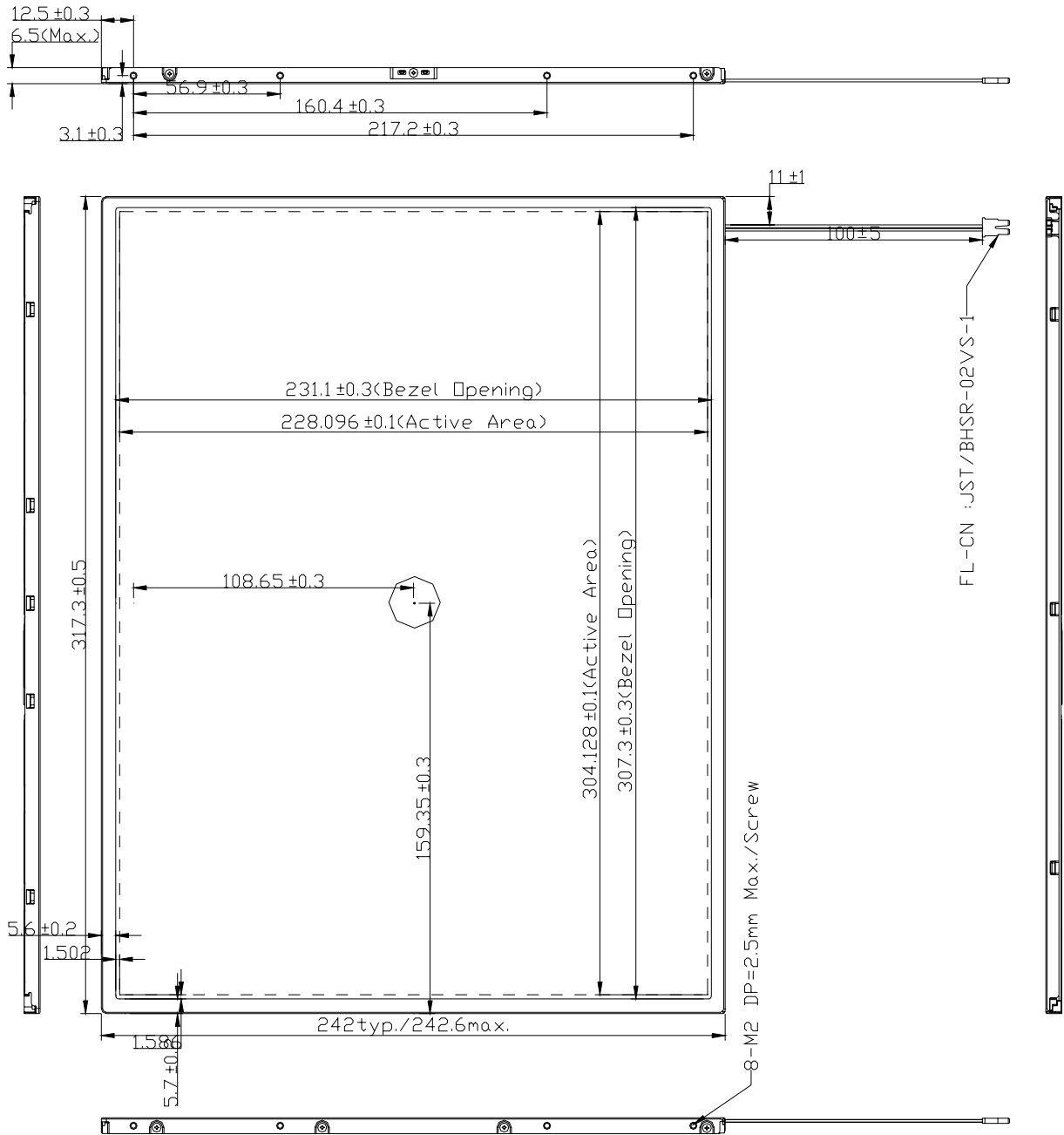



HannStar Display Corp.

Document Title	HSD150PX16 Product Information	Page No.	24 / 28
Document No.		Revision	1.0

**8.2 Back view**

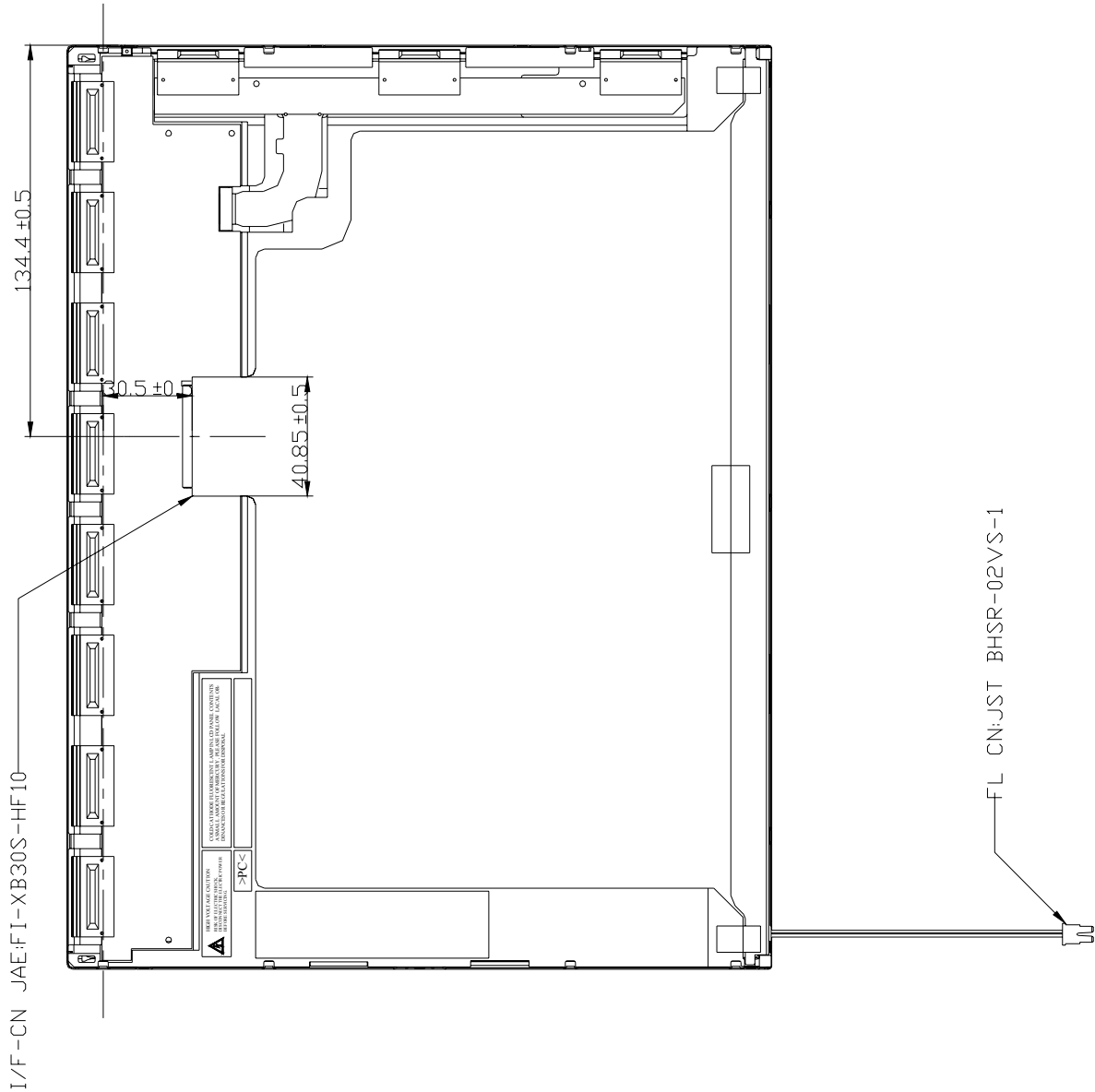



Document Title	HSD150PX16 Product Information	Page No.	25 / 28
Document No.		Revision	1.0

**9.0 PACKAGE SPECIFICATION**

**9.1 packing form**

- (1) package quantity in one carton: 20 pieces.
- (2) carton size: 454±3 mm×354±3 mm×378±3 mm.
- (3) for domestic transportation only.

**9.2 packing assembly drawings**

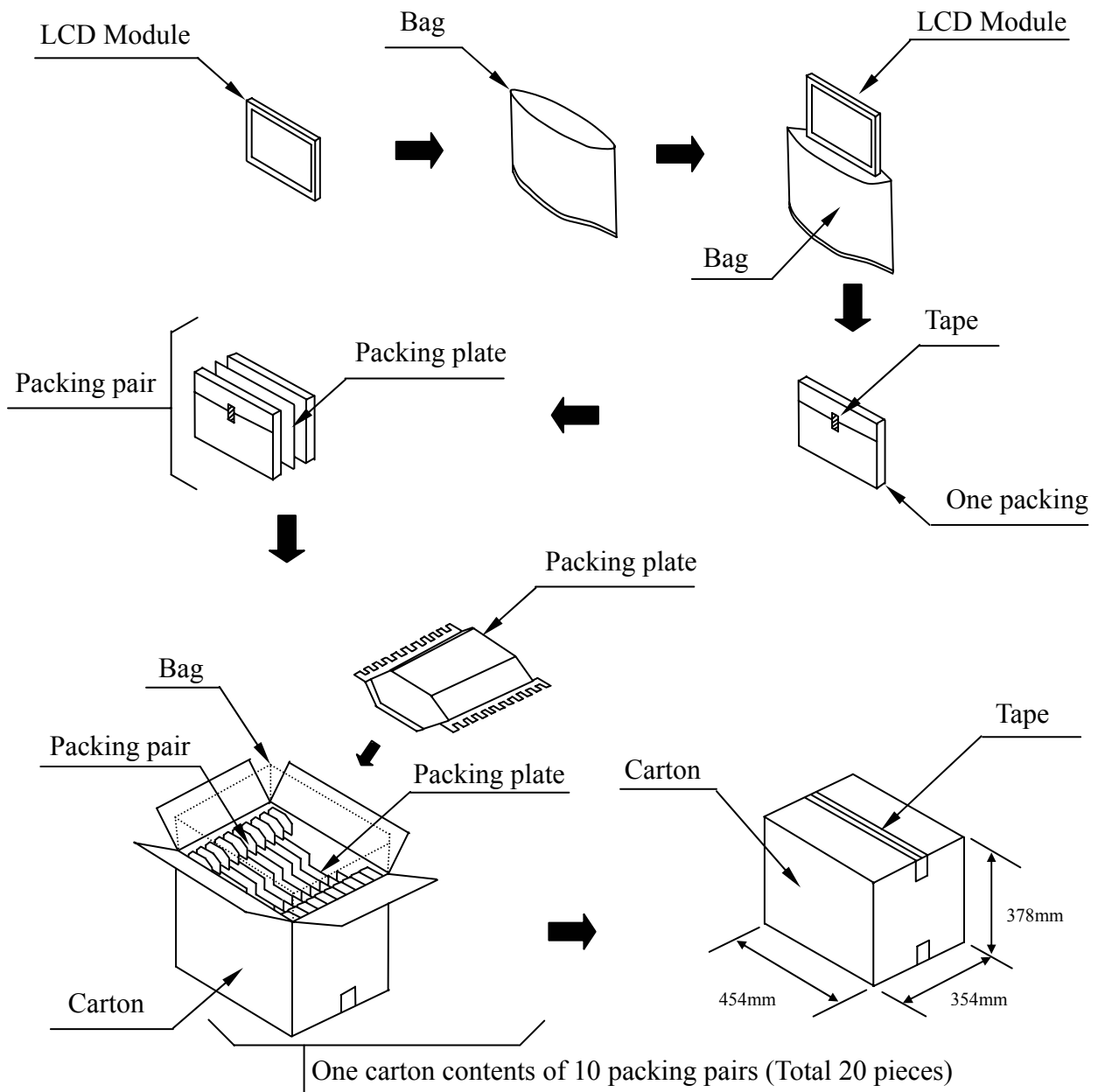

Document Title	HSD150PX16 Product Information	Page No.	26 / 28
Document No.		Revision	1.0

## 10.0 LOT MARK

### 10.1 Lot Mark

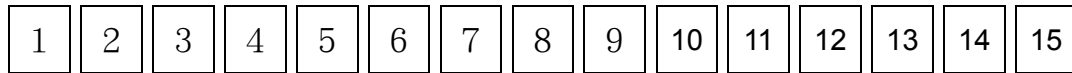

code 1,2,3,4,5,6: HannStar internal flow control code.

code 7: production location.

code 8: production year.

code 9: production month.

code 10,11,12,13,14,15: serial number.

#### Note (1) Production Year

Year	1999	2000	2001	2002	2003	2004	2005	2006	2007	2008
Mark	9	0	1	2	3	4	5	6	7	8

#### Note (2) Production Month

Month	Jan.	Feb.	Mar.	Apr.	May.	Jun.	Jul.	Aug.	Sep.	Oct.	Nov.	Dec.
Mark	1	2	3	4	5	6	7	8	9	A	B	C

### 10.2 Location of Lot Mark

- (1) The label is attached to the backside of the LCD module.
- (2) This is subject to change without prior notice.

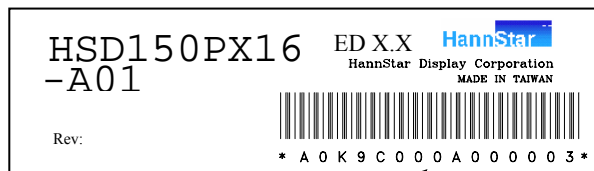

Lot mark



Document Title	HSD150PX16 Product Information	Page No.	27 / 28
Document No.		Revision	1.0

## **11.0 GENERAL PRECAUTION**

### **11.1 Use Restriction**

This product is not authorized for use in life supporting systems, aircraft navigation control systems, military systems and any other application where performance failure could be life-threatening or otherwise catastrophic.

### **11.2 Disassembling or Modification**

Do not disassemble or modify the module. It may damage sensitive parts inside LCD module, and may cause scratches or dust on the display. HannStar does not warrant the module, if customers disassemble or modify the module.

### **11.3 Breakage of LCD Panel**

11.3.1 If LCD panel is broken and liquid crystal spills out, do not ingest or inhale liquid crystal, and do not contact liquid crystal with skin.

11.3.2 If liquid crystal contacts mouth or eyes, rinse out with water immediately.

11.3.3 If liquid crystal contacts skin or cloths, wash it off immediately with alcohol and rinse thoroughly with water.

11.3.4 Handle carefully with chips of glass that may cause injury, when the glass is broken.

### **11.4 Electric Shock**

11.4.1 Disconnect power supply before handling LCD module.

11.4.2 Do not pull or fold the CCFL cable.

11.4.3 Do not touch the parts inside LCD modules and the fluorescent lamp's connector or cables in order to prevent electric shock.

### **11.5 Absolute Maximum Ratings and Power Protection Circuit**

11.5.1 Do not exceed the absolute maximum rating values, such as the supply voltage variation, input voltage variation, variation in parts' parameters, environmental temperature, etc., otherwise LCD module may be damaged.

11.5.2 Please do not leave LCD module in the environment of high humidity and high temperature for a long time.

11.5.3 It's recommended to employ protection circuit for power supply.



Document Title	HSD150PX16 Product Information	Page No.	28 / 28
Document No.		Revision	1.0

### **11.6 Operation**

11.6.1 Do not touch, push or rub the polarizer with anything harder than HB pencil lead.

11.6.2 Use fingerstalls of soft gloves in order to keep clean display quality, when persons handle the LCD module for incoming inspection or assembly.

11.6.3 When the surface is dusty, please wipe gently with absorbent cotton or other soft material.

11.6.4 Wipe off saliva or water drops as soon as possible. If saliva or water drops contact with polarizer for a long time, they may causes deformation or color fading.

11.6.5 When cleaning the adhesives, please use absorbent cotton wetted with a little petroleum benzine or other adequate solvent.

### **11.7 Mechanism**

Please mount LCD module by using mouting holes arranged in four corners tightly.

### **11.8 Static Electricity**

11.8.1 Protection film must remove very slowly from the surface of LCD module to prevent from electrostatic occurrence.

11.8.2 Because LCD module use CMOS-IC on circuit board and TFT-LCD panel, it is very weak to electrostatic discharge. Please be careful with electrostatic discharge.

Persons who handle the module should be grounded through adequate methods.

### **11.9 Strong Light Exposure**

The module shall not be exposed under strong light such as direct sunlight. Otherwise, display characteristics may be changed.

### **11.10 Disposal**

When disposing LCD module, obey the local environmental regulations.