



Document Title	HSD170MGW1 Standard Specification	Page No.	1 / 30
Document No.	DC130-002388	Revision	1.0

To :

Date :

Customer Acceptance Specification

Model: HSD170MGW1

-AXX

參考文件:DC130-002389

Accepted by:	
Signature	Date

Note:

- 1.Please contact Hannstar Display Corp. before designing your product based on this module specification.
- 2.The information contained herein is presented merely to indicate the characteristics and performance of our products. No responsibility is assumed by Hannstar for any intellectual property claims or other problems that may result from application based on the module described herein.



Document Title	HSD170MGW1 Standard Specification	Page No.	2 / 30
Document No.	DC130-002388	Revision	1.0

Record of Revisions

Rev.	Date	Sub-Model	Description of change
1.0	Nov.15.2006	A00	HSD170MGW1-A Specification was first issued.



Document Title	HSD170MGW1 Standard Specification	Page No.	3 / 30
Document No.	DC130-002388	Revision	1.0

Contents

1.0	General description	p.4
2.0	Absolute maximum ratings	p.6
3.0	Optical characteristics	p.8
4.0	Block diagram	p.12
5.0	Interface pin connection	p.15
6.0	Electrical characteristics	p.17
7.0	Outline dimension	p.25
8.0	Lot mark	p.27
9.0	Package specification	p.28
10.0	General precaution	p.29

Document Title	HSD170MGW1 Standard Specification	Page No.	4 / 30
Document No.	DC130-002388	Revision	1.0

1.0 GENERAL DESCRIPTION

1.1 Introduction

HannStar Display model HSD170MGW1-A is a color active matrix thin film transistor (TFT) liquid crystal display (LCD) that uses amorphous silicon TFT as a switching device. This model is composed of a TFT LCD panel, a driving circuit and a back light system. This TFT LCD has a 17.0 inch diagonally measured active display area with XGA resolution (900 vertical by 1440 horizontal pixel array) and can display up to 262,144 colors.

1.2 Features

- 17.0 WXGA+ for Monitor application
- High Resolution: 1440*900
- 2-ch LVDS interface system
- Input timing: DE mode
- Wide Viewing Angle
- RoHS compliance

1.3 Applications

- Notebook PC
- Desktop Monitor
- Display terminals for AV applications
- Display terminals for industrial applications

1.4 General information

Item	Specification	Unit
Outline Dimension	389.2 x 254.5 x 11.5 (Typ)	mm
Display area	367.2 (H) x 229.5 (V)	mm
Number of Pixel	1440(H) x 900(V)	pixels
Pixel pitch	0.255(H) x 0.255(V)	mm
Pixel arrangement	RGB Vertical stripe	
Display color	6 Bits / 262,144	colors
Display mode	Normally white	
Surface treatment	Antiglare (3H)	
Weight	1370	g
Back-light	2-CCFLs, Top & bottom edge side	
Input signal	2-ch LVDS	
Power Consumption	Logic System	2.4 W
	B/L System	9.8 W



Document Title	HSD170MGW1 Standard Specification	Page No.	5 / 30
Document No.	DC130-002388	Revision	1.0

1.5 Mechanical Information

	Item	Min.	Typ.	Max.	Unit
Module Size	Horizontal (H)	388.7	389.2	389.7	mm
	Vertical (V)	254.0	254.5	255.0	mm
	Depth (D)	11.2	11.5	11.8	mm
Weight (Without inverter)		-	1370	1500	g
Torque of customer screw hole		-	-	3.0	Kgf•Cm

Document Title	HSD170MGW1 Standard Specification	Page No.	6 / 30
Document No.	DC130-002388	Revision	1.0

2.0 ABSOLUTE MAXIMUM RATINGS

2.1 Absolute Rating of Environment

Item	Symbol	Min.	Max.	Unit	Note
Storage temperature	T _{STG}	-20	60	°C	
Operating temperature	T _{OPR}	0	50	°C	(1)
Vibration (non-operating)	V _{NOP}	—	1.5	G	(2)
Shock (non-operating)	S _{NOP}	—	70	G	(3)
Storage humidity	H _{STG}	10	90	%RH	(3)
Operating humidity	H _{OP}	10	80	%RH	(4)
Low pressure (operating)	P _{LOP}	697	—	hPa	(5)
Low pressure (non-operating)	P _{LNOP}	116	—	hPa	(6)

Note (1) Storage / Operating temperature

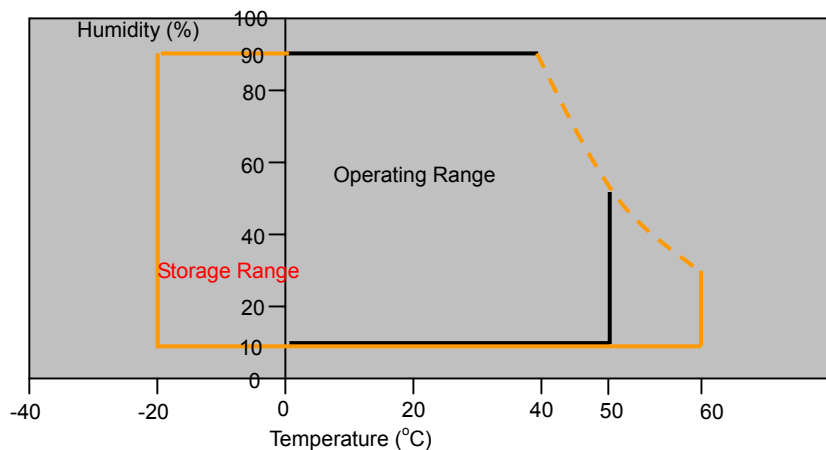

(2) 5-500-5Hz sine wave, X, Y, Z each directions, 30min/cycle.

(3) 11ms, ±X, ±Y, ±Z direction, one time each. For this shock test, it is necessary to fill the silicon rubber between the shock jig as buffer.

(4) Max wet bulb temp.= 39°C

(5) 2hrs. (10000 feet)

(6) 24hrs. (50000 feet)

Document Title	HSD170MGW1 Standard Specification	Page No.	7 / 30
Document No.	DC130-002388	Revision	1.0

2.2 Electrical Absolute Rating

2.2.1 TFT LCD Module

Item	Symbol	Min.	Max.	Unit	Note
Power supply voltage	V_{DD}	-0.3	6.0	V	(1) (2)
Logic input voltage	V_{IN}	-0.3	VDD+0.3	V	(1) (2)

2.2.2 Back-Light Unit

Item	Symbol	Min.	Max.	Unit	Note
Lamp current	I_L	3	9.0	mA	(1) (2)
Lamp frequency	f_L	30	80	KHz	(1) (2)

Note (1) Permanent damage may occur to the LCD module if beyond this specification.
Functional operation should be restricted to the conditions described under normal operating conditions.

(2) $T_a = 25 \pm 2^\circ\text{C}$

Document Title	HSD170MGW1 Standard Specification	Page No.	8 / 30
Document No.	DC130-002388	Revision	1.0

3.0 OPTICAL CHARACTERISTICS

3.1 Optical specification

Item		Symbol	Condition	Min.	Typ.	Max.	Unit	Note
Contrast		CR	$\theta=0$ viewing angle	350	500	-		(1)(2)
Response time	Rising	T_R		-	8	-	msec	(1)(3)
	Falling	T_F		-				
White luminance (Center)		Y_L		200	250	-	cd/m ²	(1)(4)(5) ($I_L=8.0mA$)
		Y_L		(180)	(230)	-	cd/m ²	($I_L=7.5mA$)
Color chromaticity (CIE1931)	Red	R_x		0.595	0.625	0.655		(1)(4)
		R_y		0.315	0.345	0.375		
	Green	G_x		0.295	0.325	0.355		
		G_y		0.525	0.555	0.585		
	Blue	B_x		0.125	0.155	0.185		
		B_y	0.115	0.145	0.175			
White	W_x	0.280	0.310	0.340				
	W_y	0.300	0.330	0.360				
Viewing angle	Hor.	θ_L	CR>10	65	70	-		
		θ_R		65	70	-		
	Ver.	θ_U		60	65	-		
		θ_D		60	65	-		
Brightness uniformity		B_{UNI}	$\theta=0$	70	-	-	%	(6)

3.2 Measuring Condition

- Measuring surrounding: dark room
- Lamp current I_{BL} : (8.0)±0.1mA, lamp freq. $F_L=55$ KHz, Inverter: TDK TBD315NR
- $V_{DD}=5.0V$, $f_V=60Hz$
- Ambient temperature: 25±2°C
- 30min. Warm-up time.

Document Title	HSD170MGW1 Standard Specification	Page No.	9 / 30
Document No.	DC130-002388	Revision	1.0

3.3 Measuring Equipment

- FPM520 of Westar Electric Corp., which utilized SR-3 for Chromaticity and BM-5A for other optical characteristics.
- Measuring spot size: 20~21mm

Note (1) Definition of Viewing Angle:

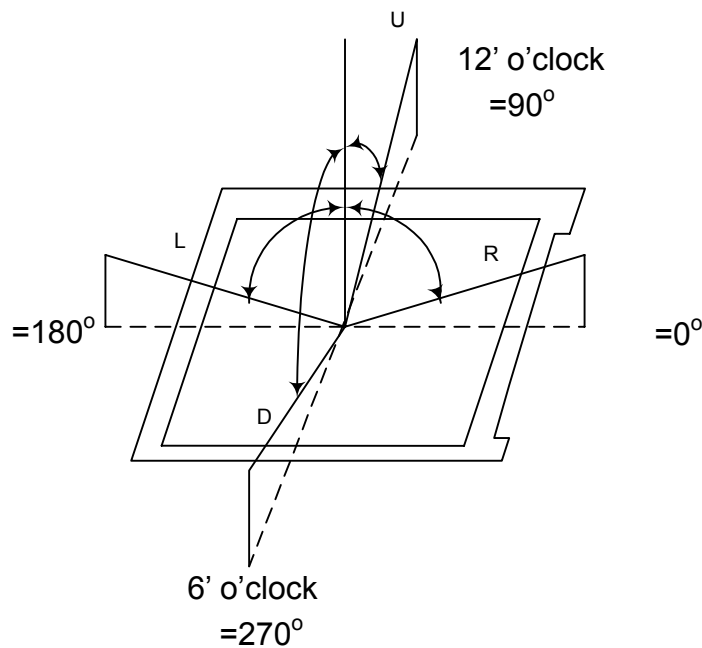

Note (2) Definition of Contrast Ratio (CR): measured at the center point of panel

$$CR = \frac{\text{Luminance with all pixels white (L63)}}{\text{Luminance with all pixels black (L0)}}$$

Note (3) Definition of Response Time: Sum of T_R and T_F

Document Title	HSD170MGW1 Standard Specification	Page No.	10 / 30
Document No.	DC130-002388	Revision	1.0

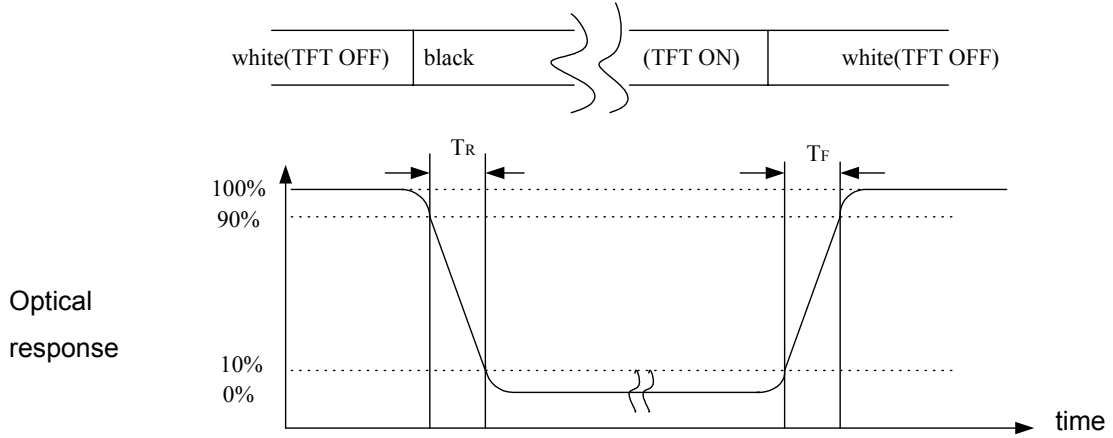

Note (4) Optical characteristic measurement setup

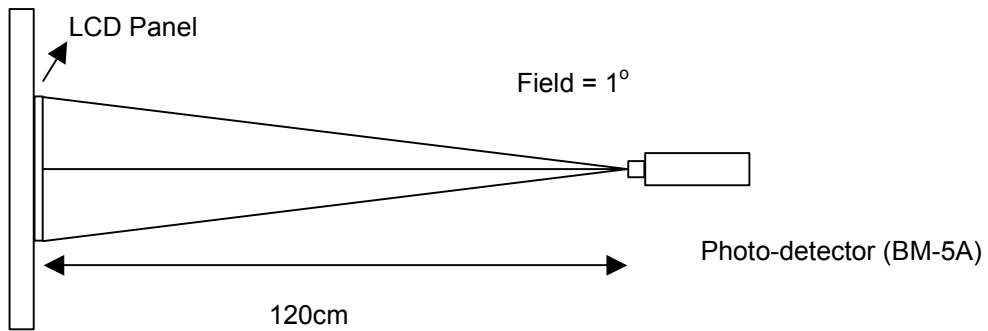

Document Title	HSD170MGW1 Standard Specification	Page No.	11 / 30
Document No.	DC130-002388	Revision	1.0

Note (5) Definition of Average Luminance of White

$$\text{Center Luminance} = Y_1$$

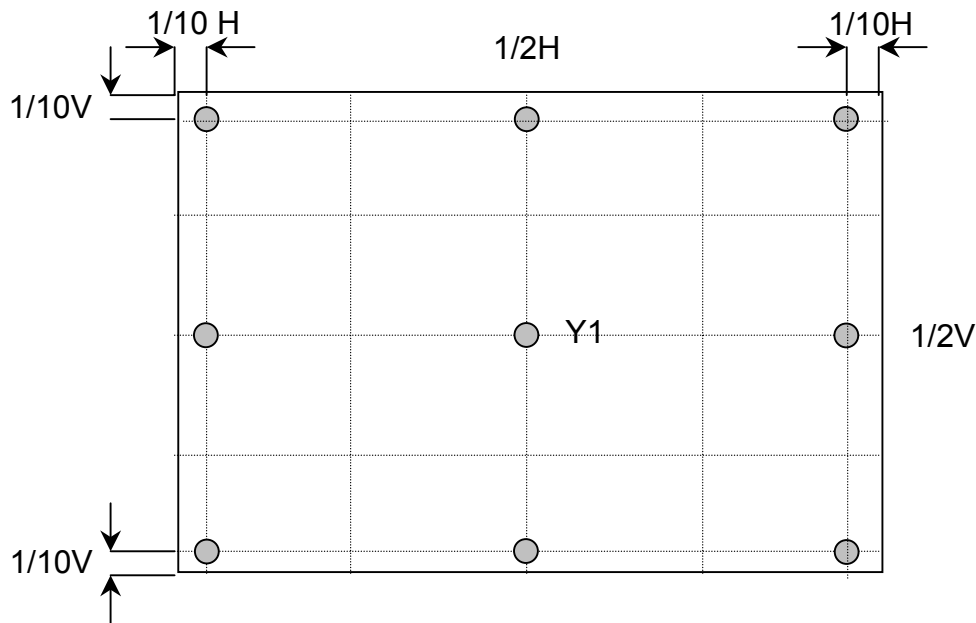

Note (6) Definition of brightness uniformity

$$\text{Luminance uniformity} = \frac{(\text{Min Luminance of 9 points})}{(\text{Max Luminance of 9 points})} \times 100\%$$

Document Title	HSD170MGW1 Standard Specification	Page No.	12 / 30
Document No.	DC130-002388	Revision	1.0

4.0 BLOCK DIAGRAM

4.1 TFT LCD Module

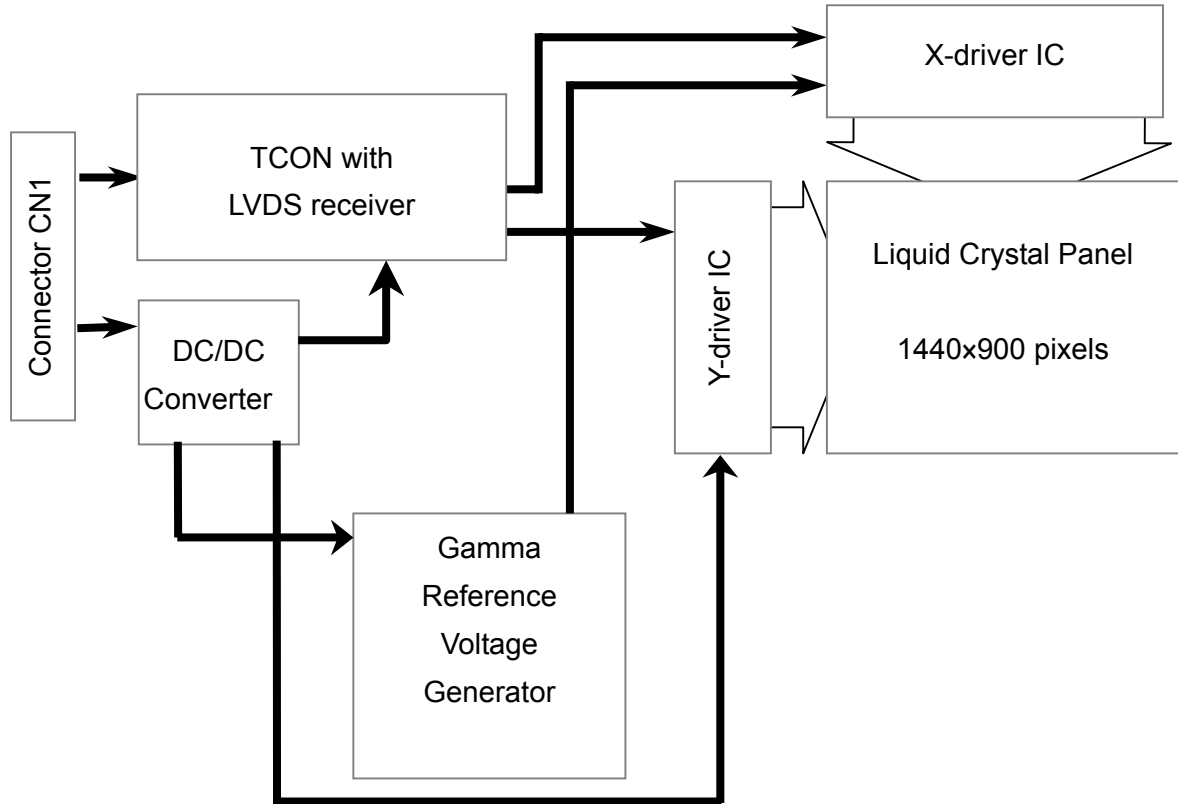

4.2 Back Light Unit

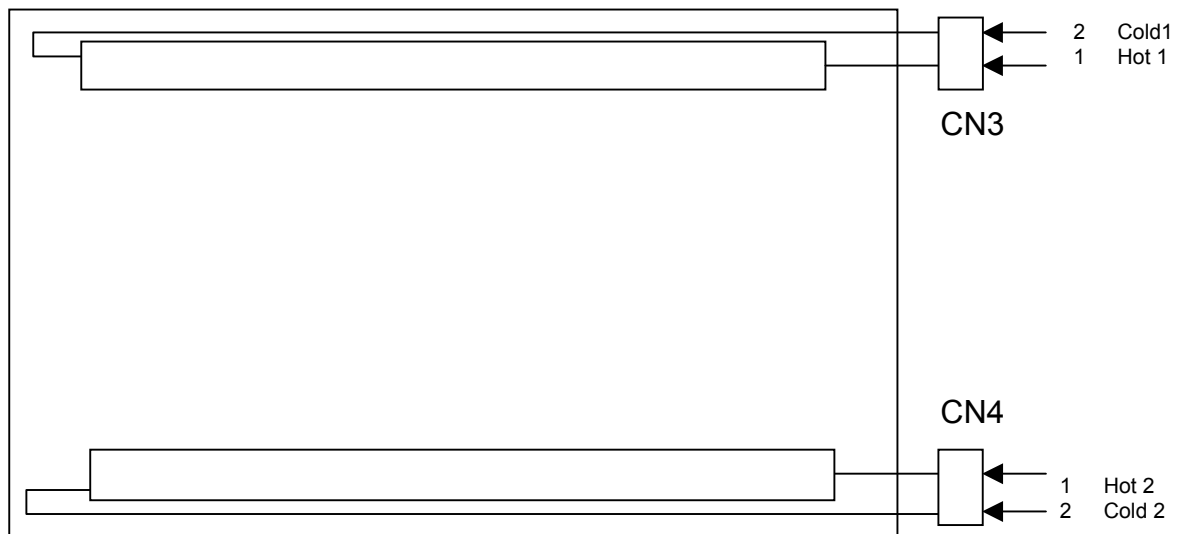

Document Title	HSD170MGW1 Standard Specification	Page No.	13 / 30
Document No.	DC130-002388	Revision	1.0

4.3 Pixel Format

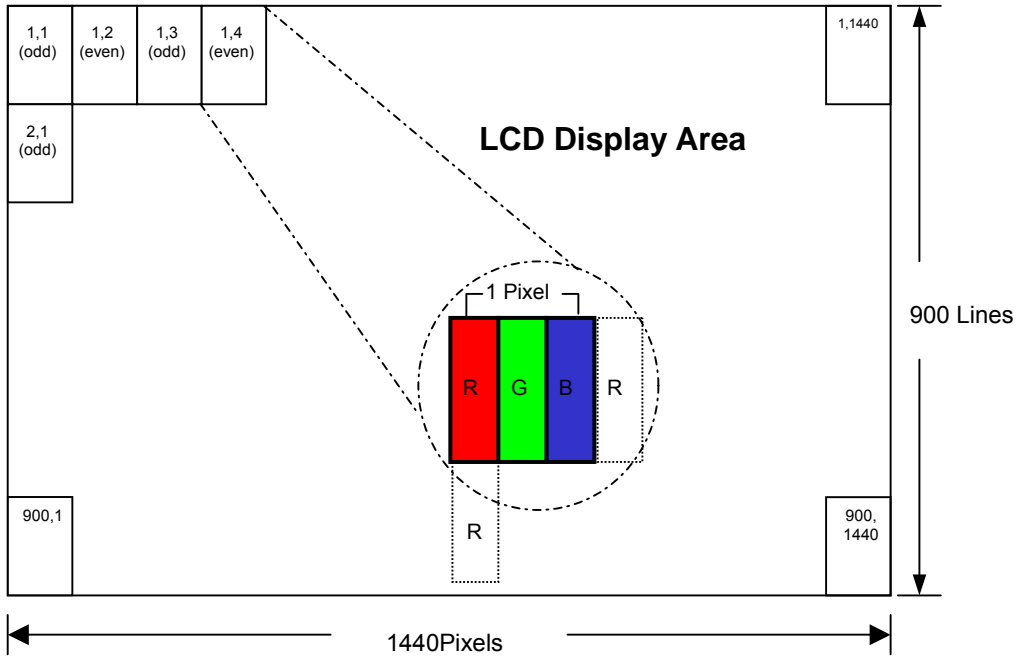

Document Title	HSD170MGW1 Standard Specification	Page No.	14 / 30
Document No.	DC130-002388	Revision	1.0

4.4 Relationship Between Displayed Color and Input

	Display	MSB						LSB						Gray scale level								
		R5	R4	R3	R2	R1	R0	G5	G4	G3	G2	G1	G0		B5	B4	B3	B2	B1	B0		
Basic color	Black	L	L	L	L	L	L	L	L	L	L	L	L	L	L	L	L	L	L	-		
	Blue	L	L	L	L	L	L	L	L	L	L	L	L	H	H	H	H	H	H	-		
	Green	L	L	L	L	L	L	L	L	L	L	L	L	L	L	L	L	L	L	-		
	Light Blue	L	L	L	L	L	L	H	H	H	H	H	H	H	H	H	H	H	H	-		
	Red	H	H	H	H	H	H	L	L	L	L	L	L	L	L	L	L	L	L	-		
	Purple	H	H	H	H	H	H	L	L	L	L	L	L	H	H	H	H	H	H	-		
	Yellow	H	H	H	H	H	H	H	H	H	H	H	H	L	L	L	L	L	L	-		
	White	H	H	H	H	H	H	H	H	H	H	H	H	H	H	H	H	H	H	-		
Gray scale of Red	Black	L	L	L	L	L	L	L	L	L	L	L	L	L	L	L	L	L	L	L0		
	Dark ↑ ↓ Light	L	L	L	L	L	H	L	L	L	L	L	L	L	L	L	L	L	L	L1		
		L	L	L	L	H	L	L	L	L	L	L	L	L	L	L	L	L	L	L2		
				:	:	:	:			:	:	:	:			:	:	:	:	L3...L60		
				H	H	H	H	L	H	L	L	L	L	L	L	L	L	L	L	L	L	L61
				H	H	H	H	H	L	L	L	L	L	L	L	L	L	L	L	L	L	L62
				H	H	H	H	H	H	L	L	L	L	L	L	L	L	L	L	L	L	Red L63
	Gray scale of Green	Black	L	L	L	L	L	L	L	L	L	L	L	L	L	L	L	L	L	L	L0	
Dark ↑ ↓ Light		L	L	L	L	L	L	L	L	L	L	L	H	L	L	L	L	L	L	L1		
		L	L	L	L	L	L	L	L	L	L	H	L	L	L	L	L	L	L	L2		
				:	:	:	:			:	:	:	:			:	:	:	:	L3...L60		
				L	L	L	L	L	L	H	H	H	H	L	H	L	L	L	L	L	L	L61
				L	L	L	L	L	L	H	H	H	H	H	L	L	L	L	L	L	L	L62
				L	L	L	L	L	L	H	H	H	H	H	H	L	L	L	L	L	L	Green L63
Gray scale of Blue		Black	L	L	L	L	L	L	L	L	L	L	L	L	L	L	L	L	L	L	L0	
	Dark ↑ ↓ Light	L	L	L	L	L	L	L	L	L	L	L	L	L	L	L	L	L	H	L1		
		L	L	L	L	L	L	L	L	L	L	L	L	L	L	L	L	H	L	L2		
				:	:	:	:			:	:	:	:			:	:	:	:	L3...L60		
				L	L	L	L	L	L	L	L	L	L	L	L	H	H	H	H	L	H	L61
				L	L	L	L	L	L	L	L	L	L	L	L	H	H	H	H	H	L	L62
				L	L	L	L	L	L	L	L	L	L	L	L	H	H	H	H	H	H	Blue L63
	Gray scale of White & Black	Black	L	L	L	L	L	L	L	L	L	L	L	L	L	L	L	L	L	L	L0	
Dark ↑ ↓ Light		L	L	L	L	L	H	L	L	L	L	L	H	L	L	L	L	L	H	L1		
		L	L	L	L	H	L	L	L	L	L	H	L	L	L	L	L	H	L	L2		
				:	:	:	:			:	:	:	:			:	:	:	:	L3...L60		
				H	H	H	H	L	H	H	H	H	H	L	H	H	H	H	H	L	H	L61
				H	H	H	H	H	L	H	H	H	H	H	L	H	H	H	H	H	L	L62
				H	H	H	H	H	H	H	H	H	H	H	H	H	H	H	H	H	H	White L63

Document Title	HSD170MGW1 Standard Specification	Page No.	15 / 30
Document No.	DC130-002388	Revision	1.0

5.0 INTERFACE PIN CONNECTION

5.1 TFT LCD Module

CN1 (INPUT SIGNAL): MDF76KBW-30S-1H (58) (HIROSE or equivalent)

MATING CONNECTOR: FI-X30M or compatible

Terminal no.	Symbol	Function	Note
1	GND	Ground	
2	VDD	Power Supply : +5.0V	
3	VDD	Power Supply : +5.0V	
4	NC	Reserved for supplier test point	
5	NC	Reserved for supplier test point	
6	NC	Reserved for supplier test point	
7	NC	Reserved for supplier test point	
8	Odd_Rin0-	- LVDS differential data input (R0-R5, G0)	(2)
9	Odd_Rin0+	+ LVDS differential data input (R0-R5, G0)	(2)
10	GND	Ground	
11	Odd_Rin1-	- LVDS differential data input (G1-G5, B0-B1)	(2)
12	Odd_Rin1+	+ LVDS differential data input (G1-G5, B0-B1)	(2)
13	GND	Ground	
14	Odd_Rin2-	- LVDS differential data input (B2-B5,NC,NC,DE)	(2)
15	Odd_Rin2+	+ LVDS differential data input (B2-B5,NC,NC,DE)	(2)
16	GND	Ground	
17	Odd_ClkIN-	- LVDS differential clock input	(2)
18	Odd_ClkIN+	+ LVDS differential clock input	(2)
19	GND	Ground	
20	Even_Rin0-	- LVDS differential data input (R0-R5, G0)	
21	Even_Rin0+	+ LVDS differential data input (R0-R5, G0)	
22	GND	Ground	
23	Even_Rin1-	- LVDS differential data input (G1-G5, B0-B1)	
24	Even_Rin1+	+ LVDS differential data input (G1-G5, B0-B1)	
25	GND	Ground	
26	Even_Rin2-	- LVDS differential data input (B2-B5,NC,NC,DE)	
27	Even_Rin2+	+ LVDS differential data input (B2-B5, NC, NC, DE)	
28	GND	Ground	
29	Even_ClkIN-	- LVDS differential clock input	
30	Even_ClkIN+	+ LVDS differential clock input	

Note (1) Please connects NC pin to nothing. Don't connect it to ground nor to other signal input.(NC pin should be open.)

Note (2) The module used a 100ohm resistor between positive and negative data lines of each receiver input.

Document Title	HSD170MGW1 Standard Specification	Page No.	16 / 30
Document No.	DC130-002388	Revision	1.0

5.2 Back-Light Unit

CN3, 4: CCFL Power Source (BHR-03VS-1/Japan Solderless Terminal MFG or equivalent)

Mating connector: SM02 (8.0) B-BHS-1/ Japan Solderless Terminal MFG or equivalent

Terminal No.	Symbol	Function
1	VL	CCFL power supply (high voltage)
2	NC	No connection
3	GL	CCFL power supply (low voltage)

Document Title	HSD170MGW1 Standard Specification	Page No.	17 / 30
Document No.	DC130-002388	Revision	1.0

6.0 ELECTRICAL CHARACTERISTICS

6.1 TFT LCD Module

Item	Symbol	Min.	Typ.	Max.	Unit	Note	
Voltage of power supply	V_{DD}	4.5	5.0	5.5	V		
Current of power supply	White	I_{DD0}	260	360	460	mA	(1)
	V-Color	I_{DD1}	370	470	570	mA	(1)
	Mosaic	I_{DD2}	515	615	715	mA	(1)
Vsync frequency	f_v	60	60	75	Hz	ref 6.5 t1	
Hsync frequency	f_H	55.469	55.935	70.635	KHz	ref 6.5 t4	
Frequency	f_{DCLK}	44.375	53.25	68.375	MHz	ref 6.5 t7	
Input rush current	I_{Rush}	-	-	1.5	A	(2)	

Note (1)

1). White & V- Color:

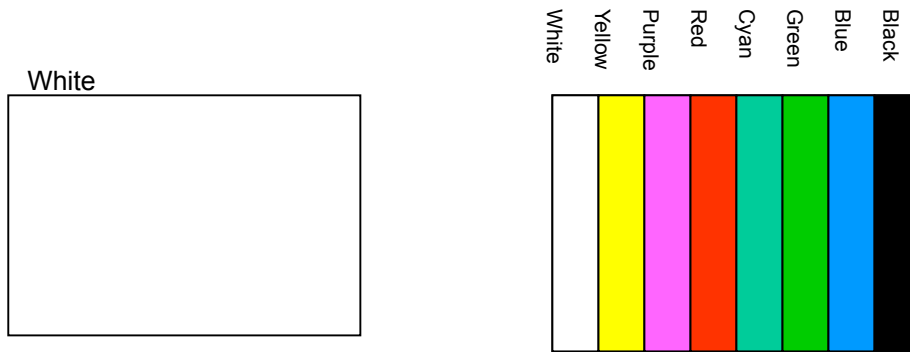

2). Mosaic: Dot checker image

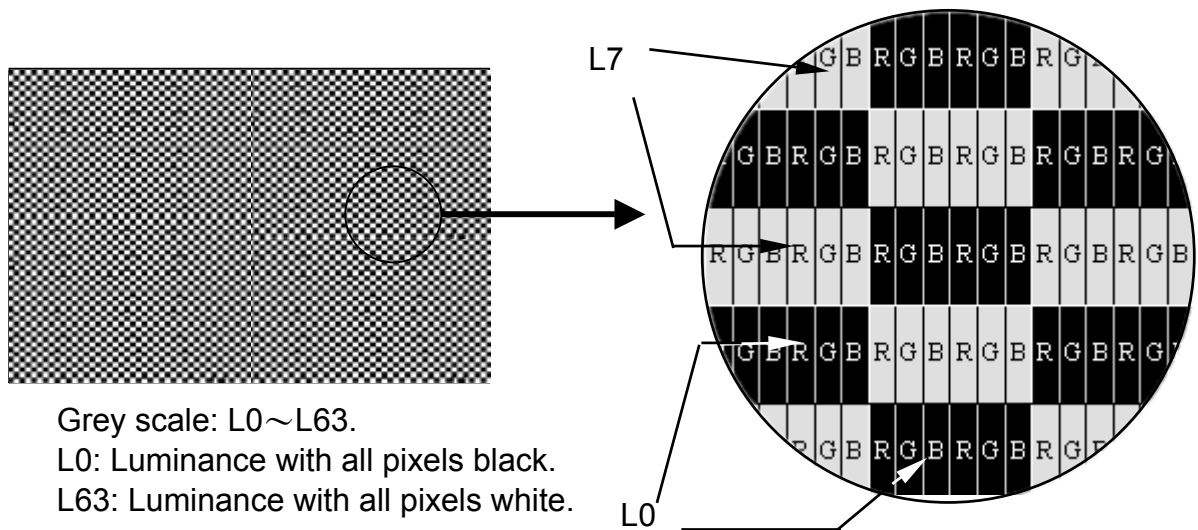

Document Title	HSD170MGW1 Standard Specification	Page No.	18 / 30
Document No.	DC130-002388	Revision	1.0

Note (2) Input Rush Current measurement condition

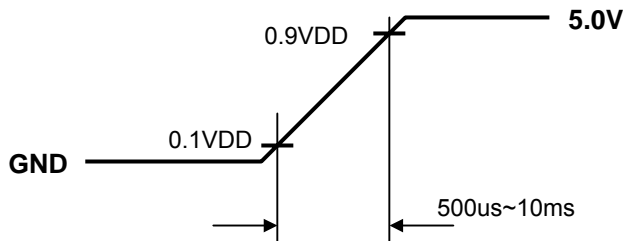
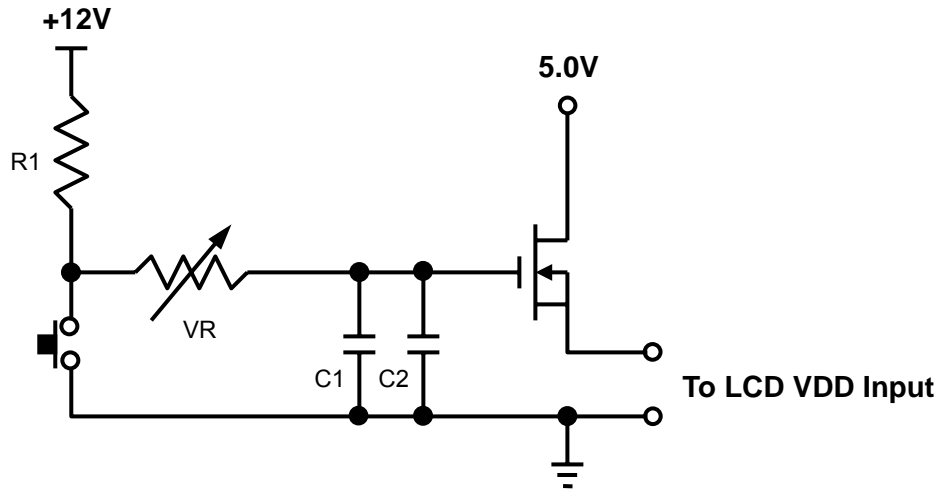

Document Title	HSD170MGW1 Standard Specification	Page No.	19 / 30
Document No.	DC130-002388	Revision	1.0

6.2 Back-Light Unit

The back- light system is an edge-lighting type with 2 CCFL.

The characteristic of the lamp is shown in the following tables.

Item	Symbol	Min.	Typ.	Max.	Unit	Note
Lamp current	IL	3.0	8.0	9.0	mA(rms)	(1)(6)
Lamp voltage	VL	-	610	-	V(rms)	(6) $I_L=8.0\text{mA}$
Frequency	fL	30	-	80	KHz	(2)
Operating lamp life time	Hr	30,000	-	-	Hour	(3) $I_L=8.0\text{mA}$
	Hr	40,000	-	-	Hour	(3) $I_L=7.5\text{mA}$
Startup voltage	Vs	1200	-	-	V(rms)	(4)(5) at 25°C
		1400				(4)(5) at 0°C

Note (1) Lamp current is measured with current meter for high frequency as shown below. Specified valued are for single lamp.

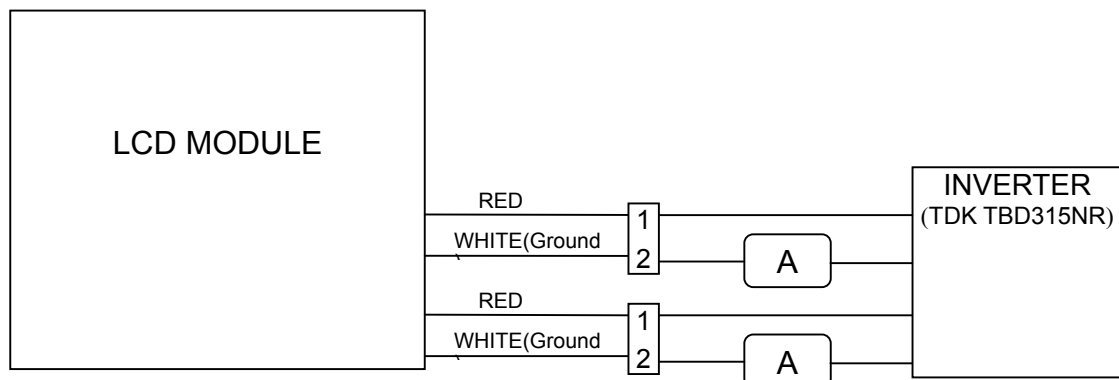

Note (2) Lamp frequency may produce interference with horizontal synchronous frequency and this may cause ripple noise on the display. Therefore lamp frequency shall be kept away from the horizontal synchronous frequency and its harmonics as far as possible in order to avoid interference.

*Suggest the inverter frequency avoid $f_L=51\sim 59\text{KHz}$

Note (3) Lamp life time (Hr) can be defined as the time in which it continues to operate under the condition: $T_a=25\pm 3^\circ\text{C}$, typical I_L value indicated in the above table and $f_L=52\text{kHz}$ until the brightness becomes less than 50%.

Note (4) CCFL inverter should be able to provide a voltage over specified value (V_s) in the above table. Lamp units need at least V_s value shown above to ignition.

Note (5) The voltage over specified value (V_s) should be applied to the lamp more than 1 second after startup. Otherwise, the lamp may not be turned on. The used lamp current is the lamp typical current.

Document Title	HSD170MGW1 Standard Specification	Page No.	20 / 30
Document No.	DC130-002388	Revision	1.0

Note (6) The output voltage waveform and current waveform of the inverter must be symmetrical (Unsymmetrical ratio is less than 10%). Please do not use the inverter which has unsymmetrical voltage and current waveform, and spike waveform. The inverter design which can provide the best optical performance, power efficiency, and lamp life should under the following conditions.

- a. The asymmetry rate of the inverter waveform should be less than 10%.
- b. The distortion rate of the waveform should be within $\sqrt{2} \pm 10\%$.
- c. The inverter output waveform should be better similar to the ideal sine wave.

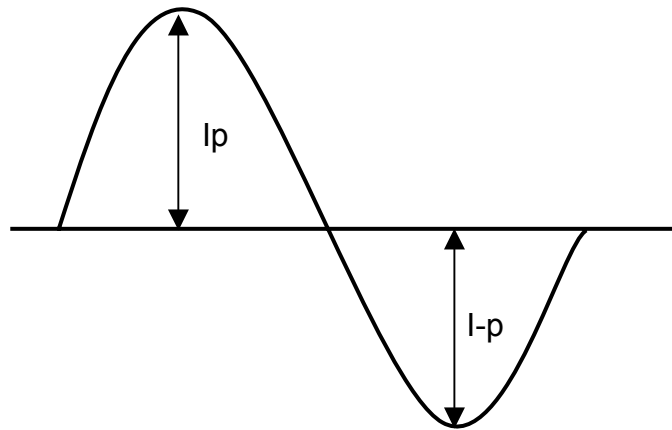

$$\text{Asymmetry rate} = |Ip - I-p| / Irms \times 100\%$$

$$\text{Distortion rate} = Ip \text{ (or } I-p) / Irms$$

Document Title	HSD170MGW1 Standard Specification	Page No.	21 / 30
Document No.	DC130-002388	Revision	1.0

6.3 Switching Characteristics for LVDS Receiver

Item	Symbol	Min.	Typ.	Max.	Unit	Conditions
Differential Input High Threshold	V _{th}	100	—	—	mV	V _{CM} =1.2V
Differential Input Low Threshold	V _{tl}	—	—	-100	mV	
Input Current	I _{IN}	—	—	±10	uA	V _{IN} =1.75V, V _{DD} =3.6V
		—	—	±10	uA	V _{IN} =0.8V, V _{DD} =3.6V
Input Voltage Range(Signal ended)	V _{IN}	1.1-(V _{ID})/2	—	1.375+(V _{ID})/2	V	
Differential input Voltage	V _{ID}	250	—	450	mV	
Common Mode Voltage Offset	V _{CM}	1.1	—	1.375	V	
Clock Frequency	f _c	44.375	53.25	68.375	MHz	
LVDS Skew Margin	t _{RSKM}	—	—	400	pS	At f _c =44.375MHz
LVDS Input Clock Jitter Tolerance	—	—	—	±2.5	%	center spread

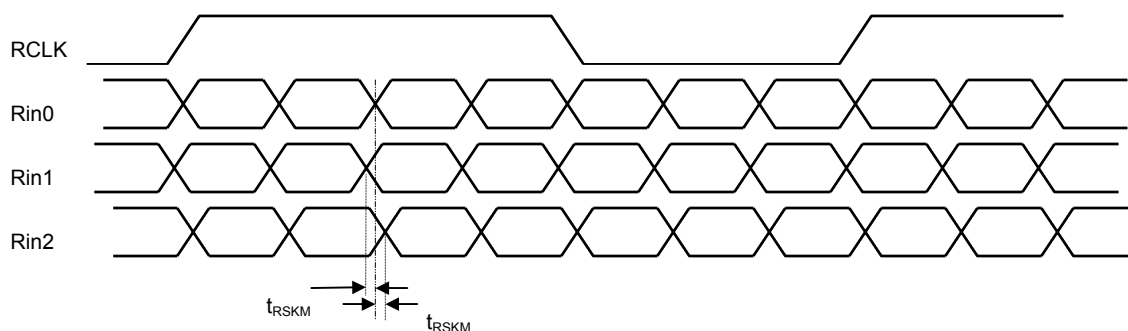

LVDS Receiver skew margin

Document Title	HSD170MGW1 Standard Specification	Page No.	22 / 30
Document No.	DC130-002388	Revision	1.0

6.4 Bit Mapping & Interface Definition

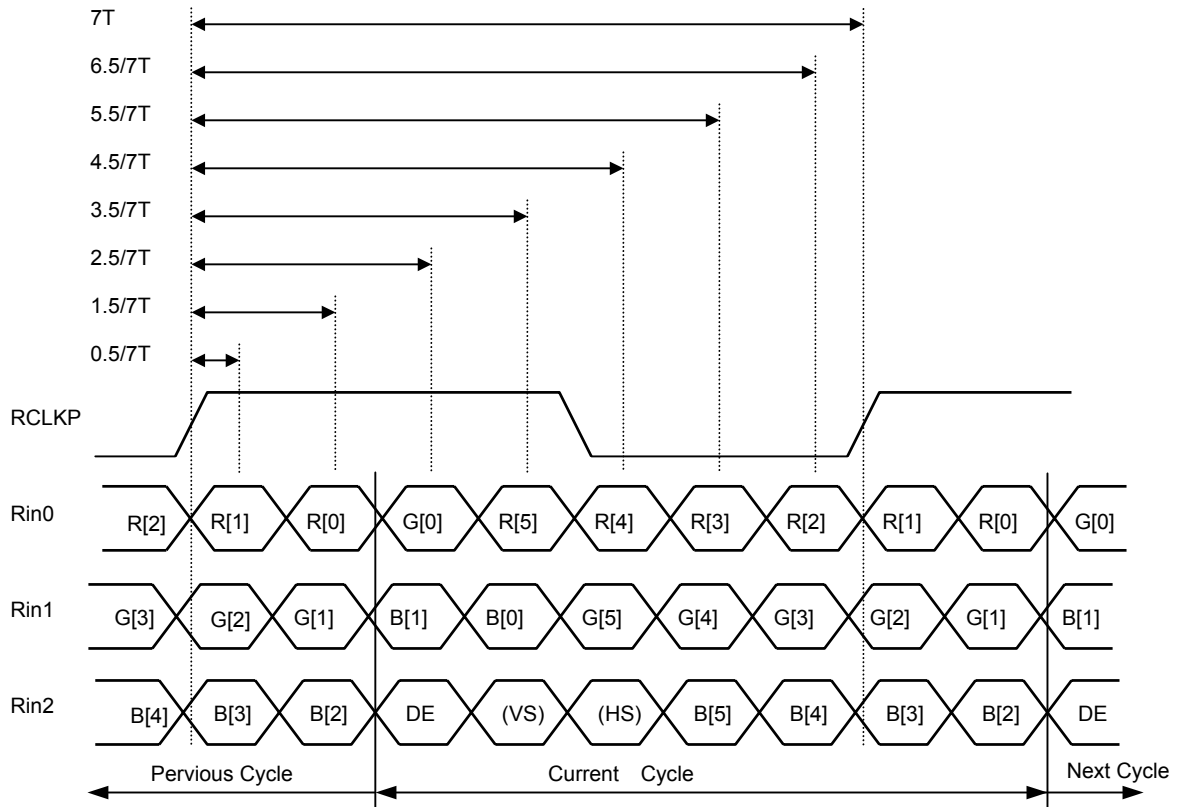

Bit Mapping & Timing Definition

Document Title	HSD170MGW1 Standard Specification	Page No.	23 / 30
Document No.	DC130-002388	Revision	1.0

6.5 Interface Timing (DE mode) ¹⁾²⁾³⁾⁴⁾⁵⁾⁶⁾

Item	Symbol	Min.	Typ.	Max.	Unit
V-Total Time	t1	926	934	942	line
Vertical Display Time	t2	900	900	900	line
Vertical Blanking Time	t3	26	34	42	line
H-Total Time	t4	800	952	968	CLK
Horizontal Display Time	t5	720	720	720	CLK
Horizontal Blanking Time	t6	80	232	248	CLK
Clock Frequency	t7 (CLK)	44.375	53.25	68.375	MHz
Frame Rate	-	60	60	75	Hz

Timing Diagram of Interface Signal (DE mode)

(1) Vertical

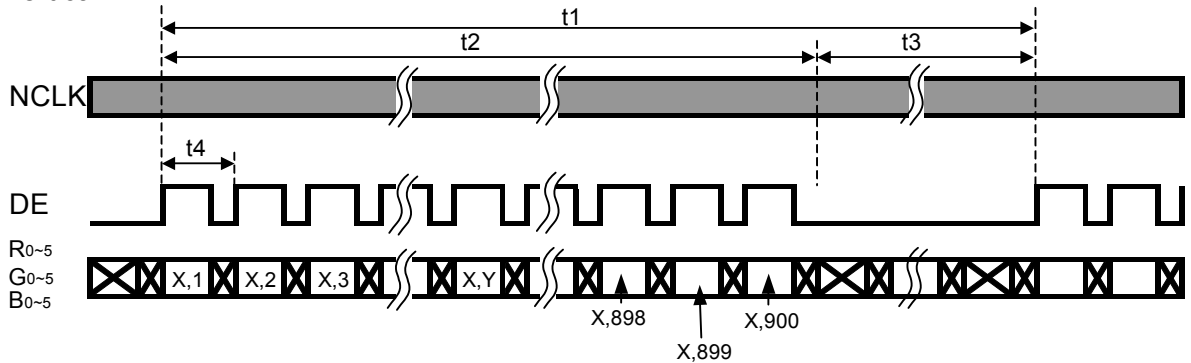

(2) Horizontal

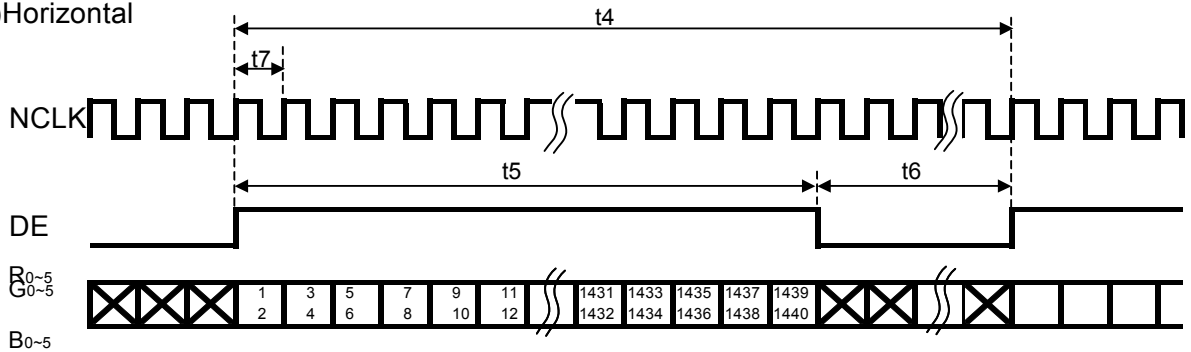

Document Title	HSD170MGW1 Standard Specification	Page No.	24 / 30
Document No.	DC130-002388	Revision	1.0

6.6 Power ON/OFF Sequence

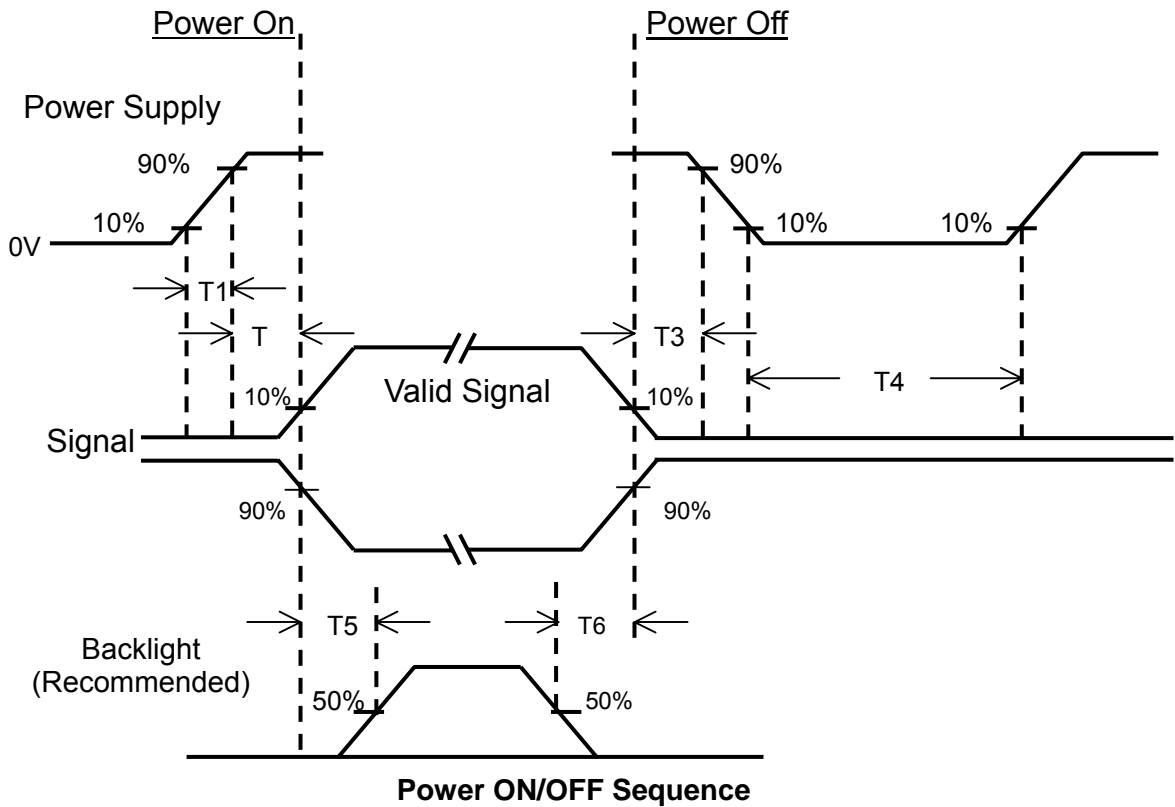

$500 \text{ usec} < T1 \leq 10 \text{ msec}$
 $0 < T2 \leq 50 \text{ msec}$
 $0 < T3 \leq 50 \text{ msec}$
 $200 \text{ ms} \leq T4$

Back-light:
 $200 \text{ ms} \leq T5$
 $200 \text{ msec} < T6$

- Note (1) Apply the lamp voltage within the LCD operation range. When the back-light turns on before the LCD operation or the LCD turns off before the back-light turns off, the display may momentarily become white.
- (2) In case of $V_{DD} = \text{off level}$, please keep the level of input signal on 0 voltage.
- (3) T4 should be measured after the module has been fully discharged between power off and on period.

Document Title	HSD170MGW1 Standard Specification	Page No.	25 / 30
Document No.	DC130-002388	Revision	1.0

7.0 OUTLINE DIMENSION

7.1 Front View Outline Dimension

Unit : mm

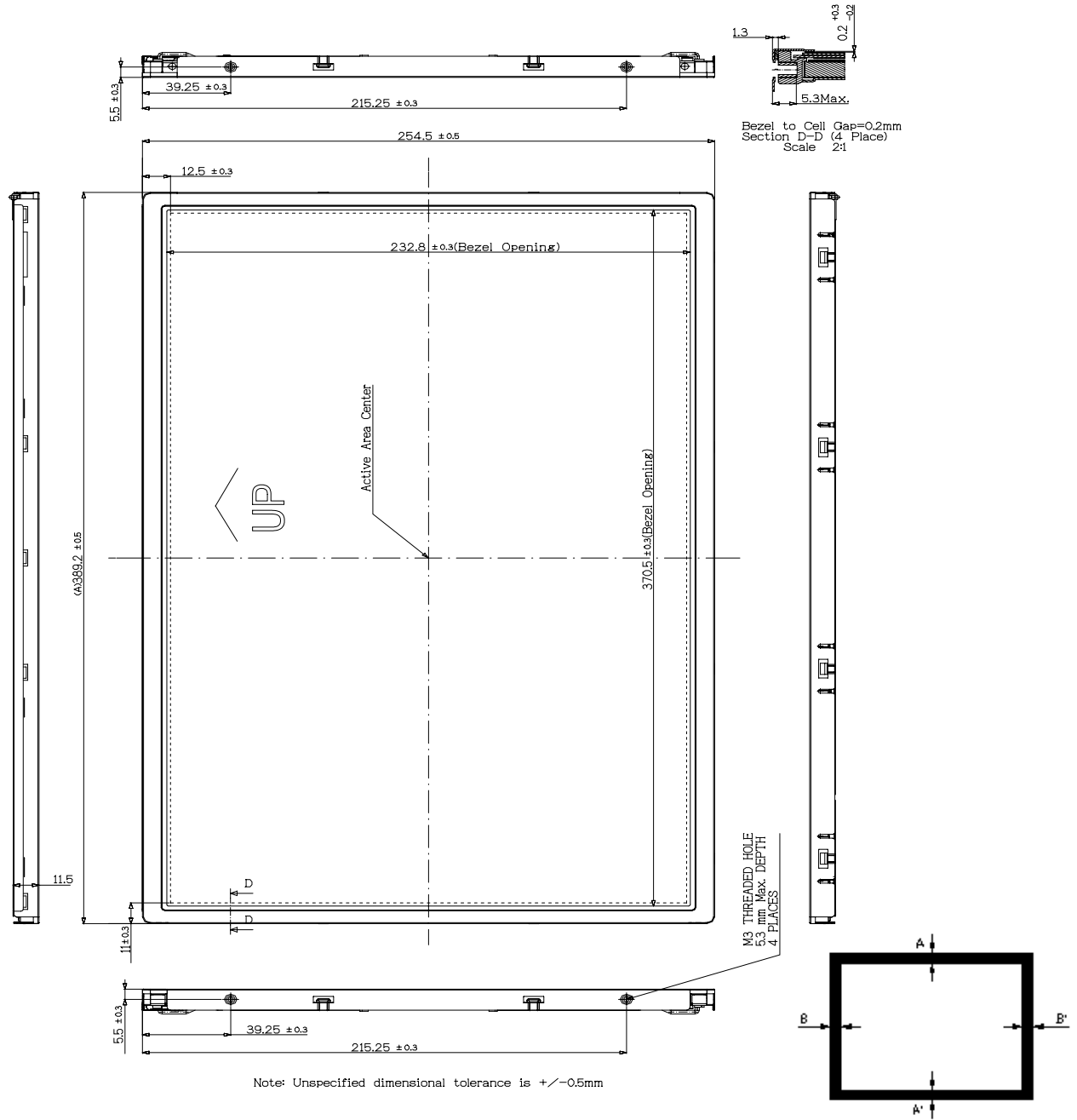

Note: Unspecified dimensional tolerance is +/-0.5mm

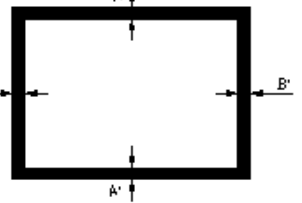

BM Assembly Tolerance
 |A-A'| ≤ 1.0 (mm)
 |B-B'| ≤ 1.0 (mm)

Document Title	HSD170MGW1 Standard Specification	Page No.	26 / 30
Document No.	DC130-002388	Revision	1.0

7.2 Back View Outline Dimension

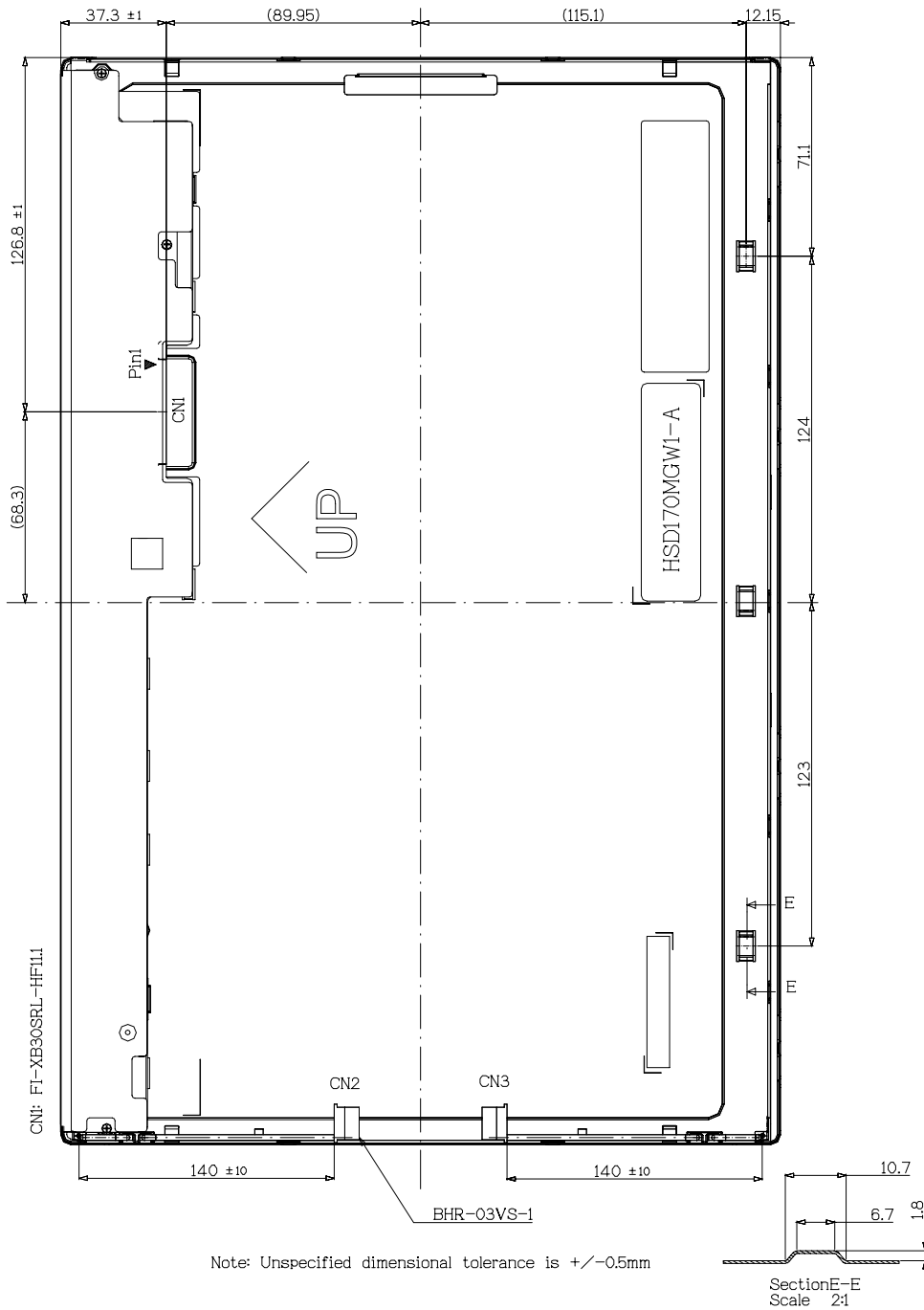

Document Title	HSD170MGW1 Standard Specification	Page No.	27 / 30
Document No.	DC130-002388	Revision	1.0

8.0 LOT MARK

8.1 Lot Mark

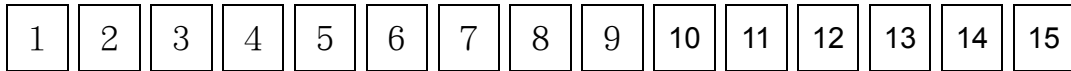

code 1,2,3,4,5,6: HannStar internal flow control code.

code 7: production location.

code 8: production year.

code 9: production month.

code 10,11,12,13,14,15: serial number.

Note (1) Production Year

Year	1999	2000	2001	2002	2003	2004	2005	2006	2007	2008
Mark	9	0	1	2	3	4	5	6	7	8

Note (2) Production Month

Month	Jan.	Feb.	Mar.	Apr.	May.	Jun.	Jul.	Aug.	Sep.	Oct	Nov.	Dec.
Mark	1	2	3	4	5	6	7	8	9	A	B	C

8.2 Location of Lot Mark

(1) The label is attached to the backside of the LCD module.

(2) This is subject to change without prior notice.



Lot mark

Document Title	HSD170MGW1 Standard Specification	Page No.	28 / 30
Document No.	DC130-002388	Revision	1.0

9.0 PACKAGE SPECIFICATION

9.1 packing form

- (1) Package quantity in one carton: 10 pieces.
- (2) Carton size: 470 x 374 x 370H (mm)

9.2 packing assembly drawings

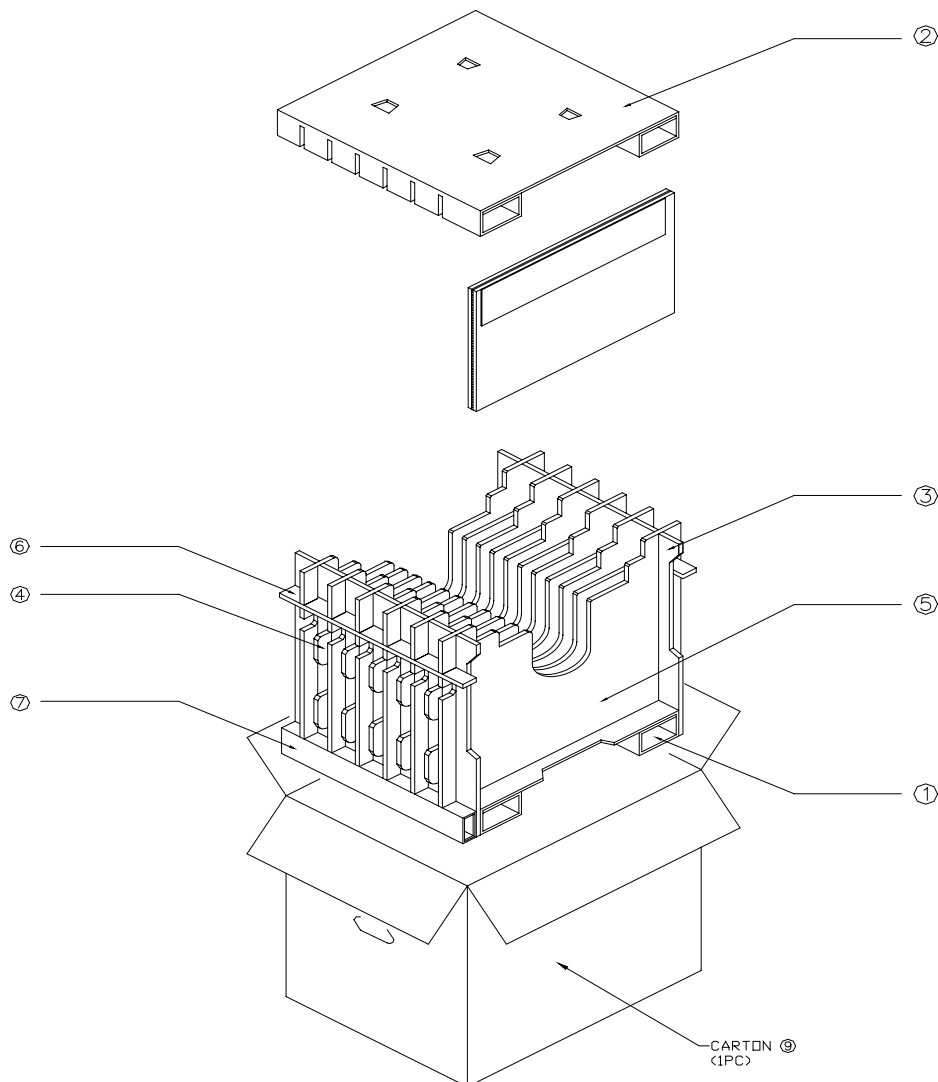

Document Title	HSD170MGW1 Standard Specification	Page No.	29 / 30
Document No.	DC130-002388	Revision	1.0

10.0 GENERAL PRECAUTION

10.1 Use Restriction

This product is not authorized for use in life supporting systems, aircraft navigation control systems, military systems and any other application where performance failure could be life-threatening or otherwise catastrophic.

10.2 Disassembling or Modification

Do not disassemble or modify the module. It may damage sensitive parts inside LCD module, and may cause scratches or dust on the display. HannStar does not warrant the module, if customers disassemble or modify the module.

10.3 Breakage of LCD Panel

- 10.3.1 If LCD panel is broken and liquid crystal spills out, do not ingest or inhale liquid crystal, and do not contact liquid crystal with skin.
- 10.3.2 If liquid crystal contacts mouth or eyes, rinse out with water immediately.
- 10.3.3 If liquid crystal contacts skin or cloths, wash it off immediately with alcohol and rinse thoroughly with water.
- 10.3.4 Handle carefully with chips of glass that may cause injury, when the glass is broken.

10.4 Electric Shock

- 10.4.1 Disconnect power supply before handling LCD module.
- 10.4.2 Do not pull or fold the CCFL cable.
- 10.4.3 Do not touch the parts inside LCD modules and the fluorescent lamp's connector or cables in order to prevent electric shock.

10.5 Absolute Maximum Ratings and Power Protection Circuit

- 10.5.1 Do not exceed the absolute maximum rating values, such as the supply voltage variation, input voltage variation, variation in parts' parameters, environmental temperature, etc., otherwise LCD module may be damaged.
- 10.5.2 Please do not leave LCD module in the environment of high humidity and high temperature for a long time.
- 10.5.3 It's recommended to employ protection circuit for power supply.

10.6 Operation

- 10.6.1 Do not touch, push or rub the polarizer with anything harder than HB pencil lead.
- 10.6.2 Use fingerstalls of soft gloves in order to keep clean display quality, when persons handle the LCD module for incoming inspection or assembly.
- 10.6.3 When the surface is dusty, please wipe gently with absorbent cotton or other soft material.
- 10.6.4 Wipe off saliva or water drops as soon as possible. If saliva or water drops contact with polarizer for a long time, they may causes deformation or color fading.
- 10.6.5 When cleaning the adhesives, please use absorbent cotton wetted with a little petroleum benzine or other adequate solvent.

Document Title	HSD170MGW1 Standard Specification	Page No.	30 / 30
Document No.	DC130-002388	Revision	1.0

10.7 Mechanism

Please mount LCD module by using mouting holes arranged in four corners tightly.

10.8 Static Electricity

10.8.1 Protection film must remove very slowly from the surface of LCD module to prevent from electrostatic occurrence.

10.8.2 Because LCD module use CMOS-IC on circuit board and TFT-LCD panel, it is very weak to electrostatic discharge. Please be careful with electrostatic discharge. Persons who handle the module should be grounded through adequate methods.

10.9 Strong Light Exposure

The module shall not be exposed under strong light such as direct sunlight. Otherwise, display characteristics may be changed.

10.10 Disposal

When disposing LCD module, obey the local environmental regulations.