



HannStar Display Corp.

Document Title	HSD170MGW1-B Formal Specification	Page No.	1 / 30
Document No.		Revision	1.0

TO :

Date :

## HannStar Product Specification

Model : **HSD170MGW1  
-B00**

- Note: 1. The information contained herein is tentative and may be changed without prior notices.  
2. Please contact HannStar Display Corp. before designing your product based on this module specification.  
3. The information contained herein is presented merely to indicate the characteristics and performance of our products. No responsibility is assumed by HannStar for any intellectual property claims or other problems that may result from application based on the module described herein.

The information contained in this document is the exclusive property of HannStar Display Corporation. It shall not be disclosed, distributed or reproduced in whole or in part without written permission of HannStar Display Corporation.



HannStar Display Corp.

Document Title	HSD170MGW1-B Formal Specification	Page No.	2 / 30
Document No.		Revision	1.0

### Record of Revisions

Rev.	Date	Sub-Model	Description of change
1.0	Jun.22, 2007	B00	HSD170MGW1-B Formal specification was first issued.

The information contained in this document is the exclusive property of HannStar Display Corporation. It shall not be disclosed, distributed or reproduced in whole or in part without written permission of HannStar Display Corporation.



HannStar Display Corp.

Document Title	HSD170MGW1-B Formal Specification	Page No.	3 / 30
Document No.		Revision	1.0

## Contents

1.0	General description .....	p.4
2.0	Absolute maximum ratings .....	p.6
3.0	Optical characteristics .....	p.8
4.0	Block diagram .....	p.12
5.0	Interface pin connection .....	p.15
6.0	Electrical characteristics .....	p.16
7.0	Outline dimension .....	p.24
8.0	Lot mark .....	p.27
9.0	Package specification .....	p.28
10.0	General precaution .....	p.29

The information contained in this document is the exclusive property of HannStar Display Corporation. It shall not be disclosed, distributed or reproduced in whole or in part without written permission of HannStar Display Corporation.



HannStar Display Corp.

Document Title	HSD170MGW1-B Formal Specification	Page No.	4 / 30
Document No.		Revision	1.0

## 1.0 GENERAL DESCRIPTION

### 1.1 Introduction

HannStar Display model HSD170MGW1-B is a color active matrix thin film transistor (TFT) liquid crystal display (LCD) that uses amorphous silicon TFT as a switching device. This model is composed of a TFT LCD panel, a driving circuit and a back light system. This TFT LCD has a 17.0 inch diagonally measured active display area with XGA resolution (900 vertical by 1440 horizontal pixel array) and can display up to 16.2M (6-bit+FRC) colors.

### 1.2 Features

- 17.0 WXGA+ for Monitor application
- High Resolution: 1440\*900
- 2-ch LVDS interface system
- LCD Timing Controller
- Wide Viewing Angle
- RoHS compatible

### 1.3 Applications

- Desktop Monitor
- Display terminals for AV applications
- Display terminals for industrial applications

### 1.4 General information

Item	Specification	Unit	
Outline Dimension	389.2 x 254.5 x 11.5 (Typ)	mm	
Display area	367.2 (H) x 229.5 (V)	mm	
Number of Pixel	1440(H) x 900(V)	pixels	
Pixel pitch	0.255(H) x 0.255(V)	mm	
Pixel arrangement	RGB Vertical stripe		
Display color	16.2M (6-bit+FRC)	colors	
Color Gamut	63% NTSC		
Display mode	Normally white		
Surface treatment	Antiglare (3H)		
Weight	1365	g	
Back-light	2-CCFLs, Top & bottom edge side		
Input signal	2-ch LVDS		
Power Consumption	Logic System	3.0(TYP.)	W
	B/L System	11.76(TYP.)	W

The information contained in this document is the exclusive property of HannStar Display Corporation. It shall not be disclosed, distributed or reproduced in whole or in part without written permission of HannStar Display Corporation.

Document Title	HSD170MGW1-B Formal Specification	Page No.	5 / 30
Document No.		Revision	1.0

## 1.5 Mechanical Information

Item		Min.	Typ.	Max.	Unit
Module Size	Horizontal (H)	388.7	389.2	389.7	mm
	Vertical (V)	254.0	254.5	255.0	mm
	Depth (D)	11.2	11.5	11.8	mm
Weight (Without inverter)		-	1365	-	g
Torque of customer screw hole		-	-	3.0	Kgf•Cm

## 2.0 ABSOLUTE MAXIMUM RATINGS

### 2.1 Absolute Rating of Environment

Item	Symbol	Min.	Max.	Unit	Note
Storage temperature	T <sub>STG</sub>	-20	60	°C	
Operating temperature	T <sub>OPR</sub>	0	50	°C	(1)
Vibration (non-operating)	V <sub>NOP</sub>	—	1.5	G	(2)
Shock (non-operating)	S <sub>NOP</sub>	—	70	G	(3)
Storage humidity	H <sub>STG</sub>	10	90	%RH	(3)
Operating humidity	H <sub>OP</sub>	10	90	%RH	(4)
Low pressure (operating)	P <sub>LOP</sub>	697	—	hPa	(5)
Low pressure (non-operating)	P <sub>LNOP</sub>	116	—	hPa	(6)

Note (1) Storage / Operating temperature

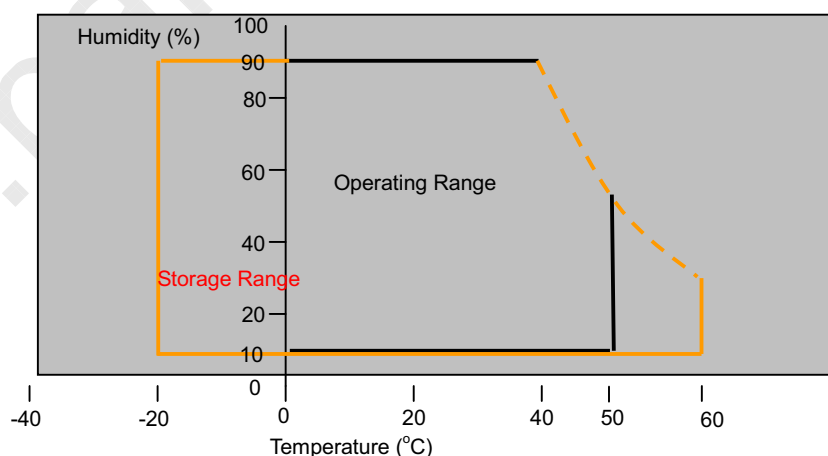

(2) 5-500-5Hz sine wave, X, Y, Z each directions, 30min/cycle.

(3) 11ms, ±X, ±Y, ±Z direction, one time each. For this shock test, it is necessary to fill the silicon rubber between the shock jig as buffer.

(4) Max wet bulb temp.= 39°C

(5) 2hrs. (10000 feet)

(6) 24hrs. (50000 feet)



HannStar Display Corp.

Document Title	HSD170MGW1-B Formal Specification	Page No.	6 / 30
Document No.		Revision	1.0

## 2.2 Electrical Absolute Rating

### 2.2.1 TFT LCD Module

Item	Symbol	Min.	Max.	Unit	Note
Power supply voltage	$V_{DD}$	-0.3	6.0	V	(1) (2)
Logic input voltage	$V_{IN}$	-0.3	VDD+0.3	V	(1) (2)

### 2.2.2 Back-Light Unit

Item	Symbol	Min.	Max.	Unit	Note
Lamp current	$I_L$	3.5	8.0	mA	(1) (2)
Lamp frequency	$f_L$	40	60	KHz	(1) (2)

Note (1) Permanent damage may occur to the LCD module if beyond this specification. Functional operation should be restricted to the conditions described under normal operating conditions.

(2)  $T_a = 25 \pm 2^\circ\text{C}$

Document Title	HSD170MGW1-B Formal Specification	Page No.	7 / 30
Document No.		Revision	1.0

### 3.0 OPTICAL CHARACTERISTICS

#### 3.1 Optical specification

Item		Symbol	Condition	Min.	Typ.	Max.	Unit	Note	
Contrast		CR	$\theta=0$ viewing angle	500	600	-		(1)(2)	
Response time	Rising	$T_R$		-	3	5	msec	(1)(3)	
	Falling	$T_F$		-	5	7			
White luminance (Center)		$Y_L$			200	250	-	cd/m <sup>2</sup>	(1)(4)(5) ( $I_L=7.5mA$ )
Color chromaticity (CIE1931)	Red	$R_x$		-	0.621	0.651	0.681		(1)(4)
		$R_y$		-	0.302	0.332	0.362		
	Green	$G_x$		-	0.288	0.318	0.348		
		$G_y$		-	0.539	0.569	0.599		
	Blue	$B_x$		-	0.117	0.147	0.177		
		$B_y$		-	0.061	0.091	0.121		
	White	$W_x$	-	0.283	0.313	0.343			
		$W_y$	-	0.299	0.329	0.359			
Viewing angle	Hor.	$\theta_L$	CR>10	70	80	-			
		$\theta_R$		70	80	-			
	Ver.	$\theta_D$		75	85	-			
		$\theta_U$		55	65	-			
Viewing angle	Hor.	$\theta_L$	CR>5	75	85	-			
		$\theta_R$		75	85	-			
	Ver.	$\theta_D$		75	85	-			
		$\theta_U$		75	85	-			
Brightness uniformity		$B_{UNI}$	$\theta=0$	70	75	-	%	(6)	

#### 3.2 Measuring Condition

- Measuring surrounding: dark room
- Lamp current  $I_{BL}$ :  $7.5 \pm 0.1mA$ , lamp freq.  $F_L=50$  KHz, Inverter: TDK TBD315NR-1
- $V_{DD}=5.0V$ ,  $f_v=60Hz$
- Ambient temperature:  $25 \pm 2^\circ C$
- 30min. Warm-up time.

The information contained in this document is the exclusive property of HannStar Display Corporation. It shall not be disclosed, distributed or reproduced in whole or in part without written permission of HannStar Display Corporation.

Document Title	HSD170MGW1-B Formal Specification	Page No.	8 / 30
Document No.		Revision	1.0

### 3.3 Measuring Equipment

- FPM520 of Westar Electric Corp., which utilized SR-3 for Chromaticity and BM-5A for other optical characteristics.
- Measuring spot size: 20~21mm

Note (1) Definition of Viewing Angle:

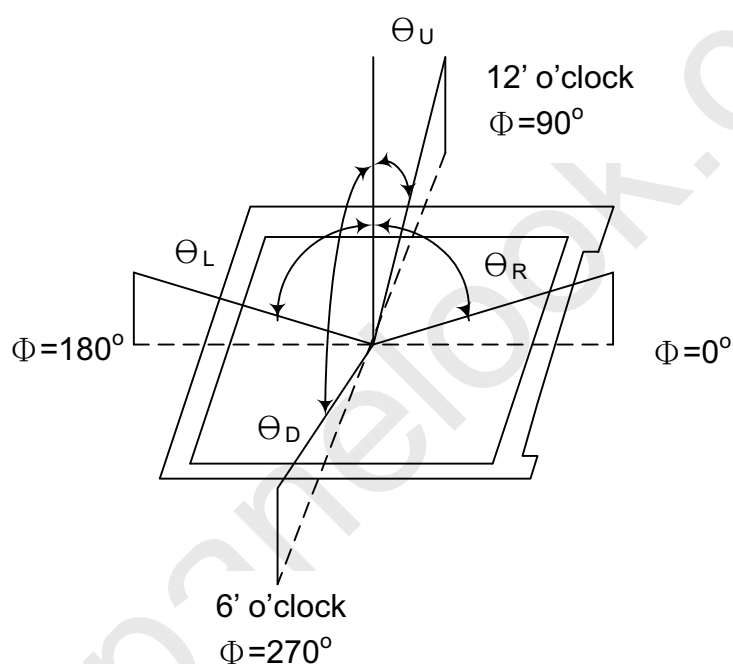

Note (2) Definition of Contrast Ratio (CR): measured at the center point of panel

$$CR = \frac{\text{Luminance with all pixels white (L63)}}{\text{Luminance with all pixels black (L0)}}$$

Note (3) Definition of Response Time: Sum of  $T_R$  and  $T_F$



Document Title	HSD170MGW1-B Formal Specification	Page No.	9 / 30
Document No.		Revision	1.0

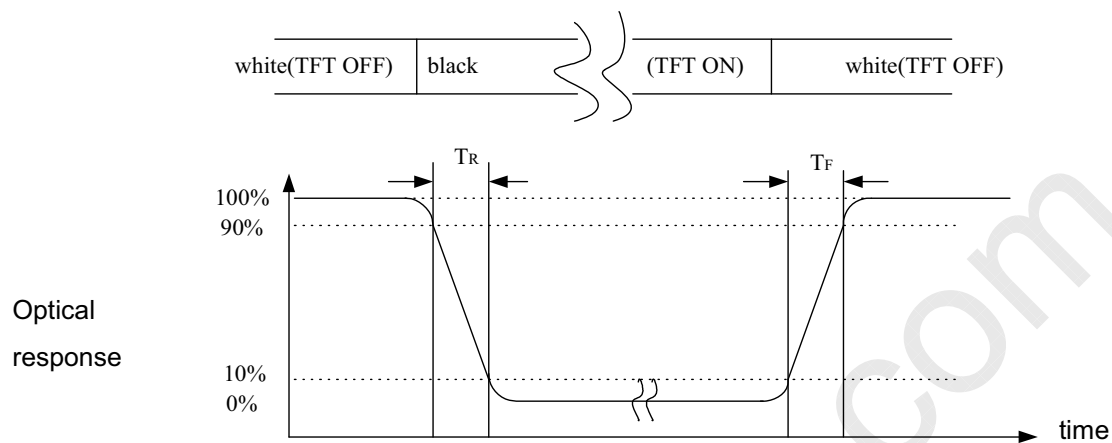

Note (4) Optical characteristic measurement setup

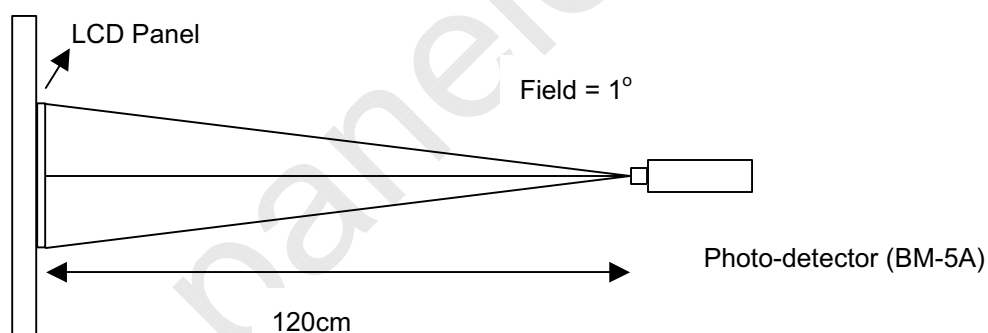

Document Title	HSD170MGW1-B Formal Specification	Page No.	10 / 30
Document No.		Revision	1.0

#### Note (5) Definition of Average Luminance of White

$$\text{Center Luminance} = Y_1$$

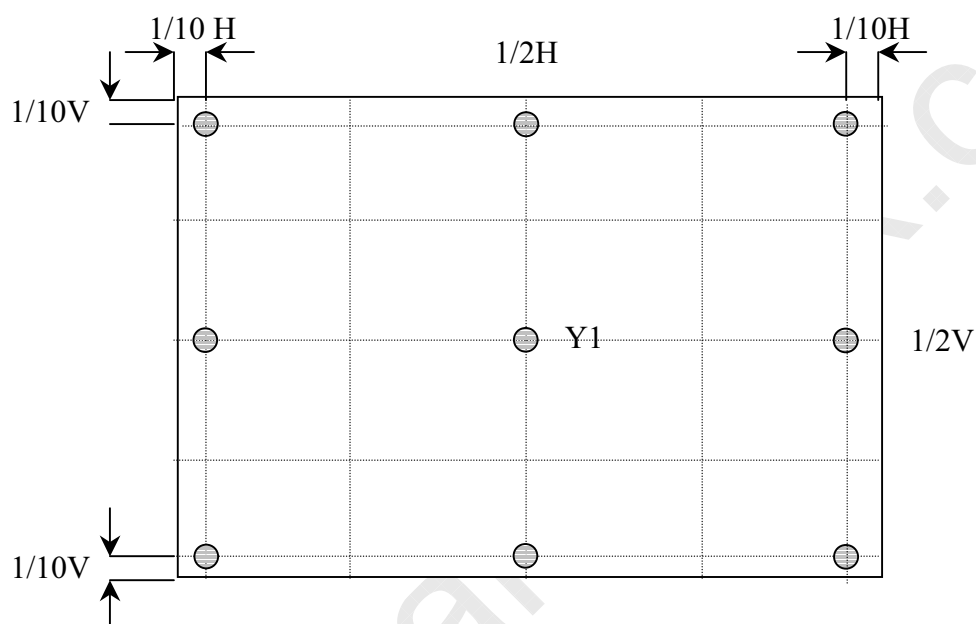

#### Note (6) Definition of brightness uniformity

$$\text{Luminance uniformity} = \frac{(\text{Min Luminance of 9 points})}{(\text{Max Luminance of 9 points})} \times 100\%$$

Document Title	HSD170MGW1-B Formal Specification	Page No.	11 / 30
Document No.		Revision	1.0

## 4.0 BLOCK DIAGRAM

### 4.1 TFT LCD Module

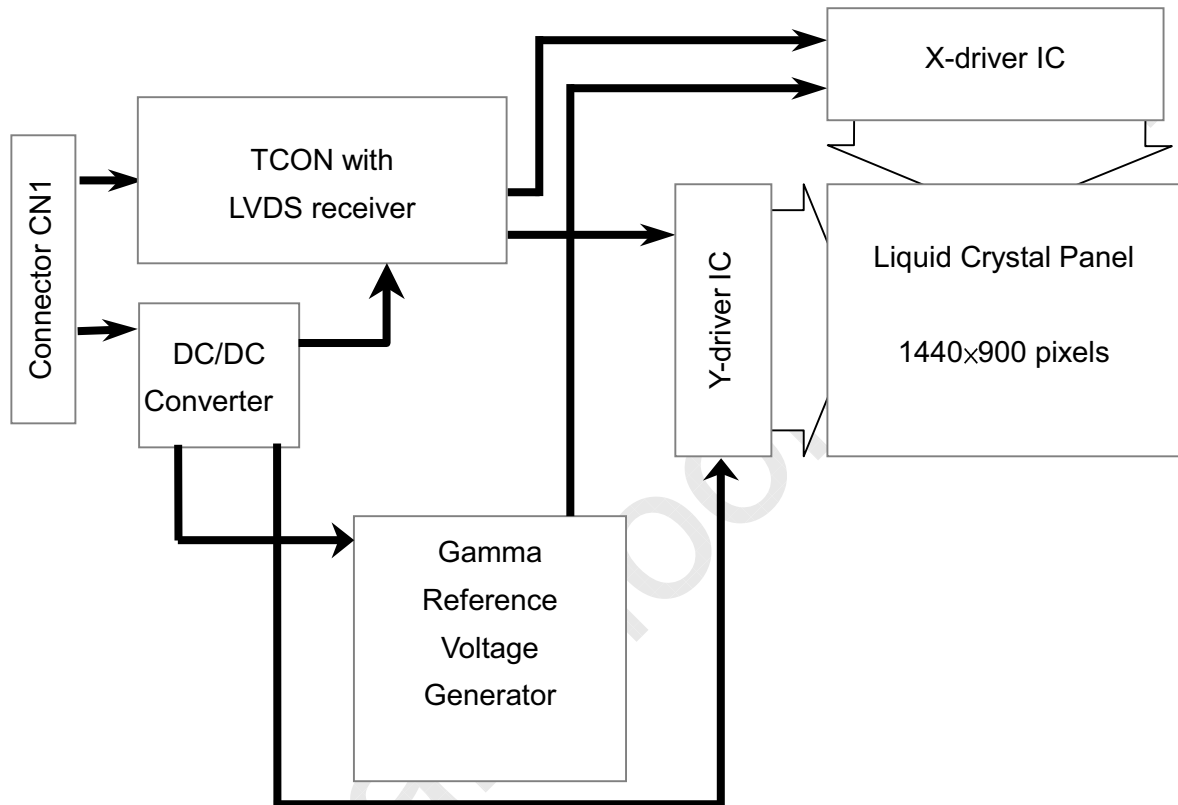

### 4.2 Back Light Unit

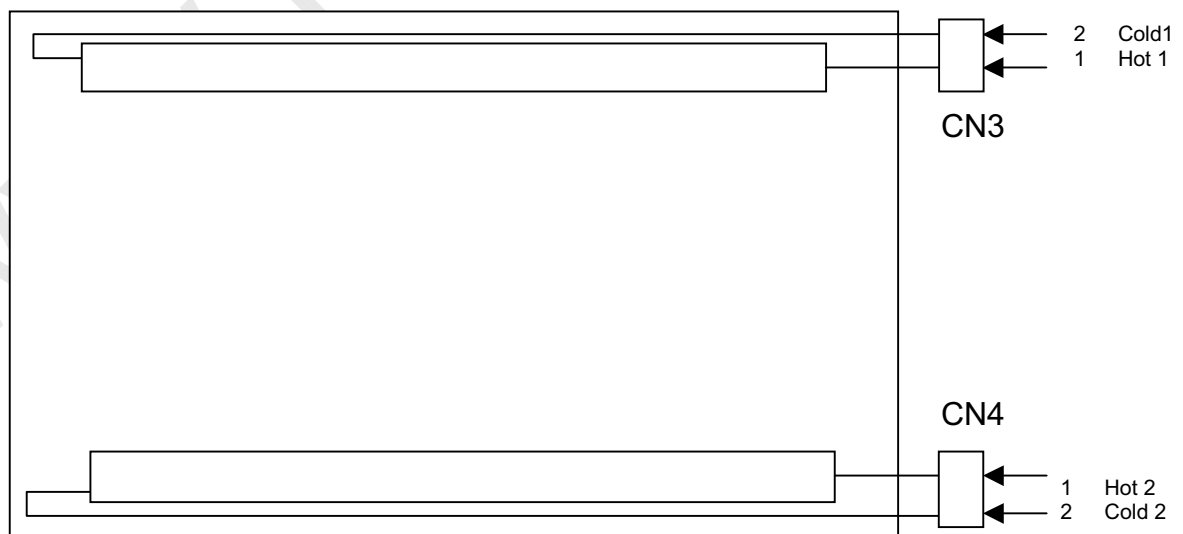

The information contained in this document is the exclusive property of HannStar Display Corporation. It shall not be disclosed, distributed or reproduced in whole or in part without written permission of HannStar Display Corporation.



HannStar Display Corp.

Document Title	HSD170MGW1-B Formal Specification	Page No.	12 / 30
Document No.		Revision	1.0

### 4.3 Pixel Format

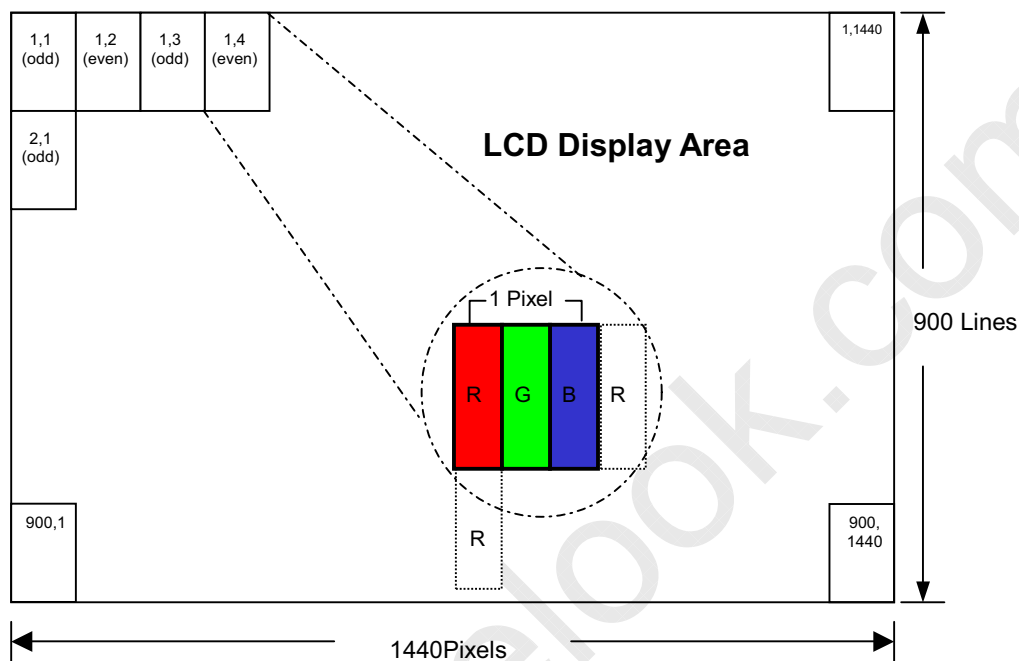

The information contained in this document is the exclusive property of HannStar Display Corporation. It shall not be disclosed, distributed or reproduced in whole or in part without written permission of HannStar Display Corporation.



HannStar Display Corp.

Document Title	HSD170MGW1-B Formal Specification	Page No.	13 / 30
Document No.		Revision	1.0

#### 4.4 Relationship Between Displayed Color and Input

Display	MSB						LSB						MSB						LSB						Gray scale level
	R5	R4	R3	R2	R1	R0	G5	G4	G3	G2	G1	G0	B5	B4	B3	B2	B1	B0							
Basic color	Black	L	L	L	L	L	L	L	L	L	L	L	L	L	L	L	L	L	L	-					
	Blue	L	L	L	L	L	L	L	L	L	L	L	L	L	H	H	H	H	H	-					
	Green	L	L	L	L	L	L	L	H	H	H	H	H	L	L	L	L	L	L	-					
	Light Blue	L	L	L	L	L	L	L	H	H	H	H	H	H	H	H	H	H	H	-					
	Red	H	H	H	H	H	H	L	L	L	L	L	L	L	L	L	L	L	L	-					
	Purple	H	H	H	H	H	H	L	L	L	L	L	L	L	H	H	H	H	H	-					
	Yellow	H	H	H	H	H	H	H	H	H	H	H	H	L	L	L	L	L	L	-					
	White	H	H	H	H	H	H	H	H	H	H	H	H	H	H	H	H	H	H	-					
Gray scale of Red	Black	L	L	L	L	L	L	L	L	L	L	L	L	L	L	L	L	L	L	L0					
	Dark ↕ Light	L	L	L	L	L	H	L	L	L	L	L	L	L	L	L	L	L	L	L1					
		L	L	L	L	H	L	L	L	L	L	L	L	L	L	L	L	L	L	L2					
		:						:						:						L3...L60					
		H	H	H	H	L	H	L	L	L	L	L	L	L	L	L	L	L	L	L61					
	H	H	H	H	H	L	L	L	L	L	L	L	L	L	L	L	L	L	L62						
	Red	H	H	H	H	H	H	L	L	L	L	L	L	L	L	L	L	L	L	Red L63					
Gray scale of Green	Black	L	L	L	L	L	L	L	L	L	L	L	L	L	L	L	L	L	L	L0					
	Dark ↑ Light	L	L	L	L	L	L	L	L	L	L	L	H	L	L	L	L	L	L	L1					
		L	L	L	L	L	L	L	L	L	L	H	L	L	L	L	L	L	L	L2					
		:						:						:						L3...L60					
		L	L	L	L	L	L	L	H	H	H	H	L	H	L	L	L	L	L	L	L61				
	L	L	L	L	L	L	L	H	H	H	H	H	L	L	L	L	L	L	L	L62					
	Green	L	L	L	L	L	L	L	H	H	H	H	H	L	L	L	L	L	L	Green L63					
Gray scale of Blue	Black	L	L	L	L	L	L	L	L	L	L	L	L	L	L	L	L	L	L	L0					
	Dark ↑ Light	L	L	L	L	L	L	L	L	L	L	L	L	L	L	L	L	H	L	L1					
		L	L	L	L	L	L	L	L	L	L	L	L	L	L	L	L	H	L	L2					
		:						:						:						L3...L60					
		L	L	L	L	L	L	L	L	L	L	L	L	L	H	H	H	H	L	H	L61				
	L	L	L	L	L	L	L	L	L	L	L	L	L	H	H	H	H	H	L	L62					
	Blue	L	L	L	L	L	L	L	L	L	L	L	L	L	H	H	H	H	H	Blue L63					
Gray scale of White & Black	Black	L	L	L	L	L	L	L	L	L	L	L	L	L	L	L	L	L	L	L0					
	Dark ↑ Light	L	L	L	L	L	H	L	L	L	L	L	H	L	L	L	L	L	H	L1					
		L	L	L	L	H	L	L	L	L	L	H	L	L	L	L	L	H	L	L2					
		:						:						:						L3...L60					
		H	H	H	H	L	H	H	H	H	H	L	H	H	H	H	H	L	H	L61					
	H	H	H	H	H	L	H	H	H	H	H	L	H	H	H	H	H	L	L62						
	White	H	H	H	H	H	H	H	H	H	H	H	H	H	H	H	H	H	H	White L63					

The information contained in this document is the exclusive property of HannStar Display Corporation. It shall not be disclosed, distributed or reproduced in whole or in part without written permission of HannStar Display Corporation.



HannStar Display Corp.

Document Title	HSD170MGW1-B Formal Specification	Page No.	14 / 30
Document No.		Revision	1.0

## 5.0 INTERFACE PIN CONNECTION

### 5.1 TFT LCD Module

Interface Connector (30-pins ) (HIROSE: MDF76URW-30S-1H(58) or equivalent)

Pin No.	Signal	Description
1	RinO0-	Receiver Signal (-)
2	RinO0+	Receiver Signal (+)
3	RinO1-	Receiver Signal (-)
4	RinO1+	Receiver Signal (+)
5	RinO2-	Receiver Signal (-)
6	RinO2+	Receiver Signal (+)
7	VSS	Ground
8	RinOC-	Clock Signal (-)
9	RinOC+	Clock Signal (+)
10	RinO3-	Receiver Signal (-)
11	RinO3+	Receiver Signal (+)
12	RinE0-	Receiver Signal (-)
13	RinE0+	Receiver Signal (+)
14	VSS	Ground
15	RinE1-	Receiver Signal (-)
16	RinE1+	Receiver Signal (+)
17	VSS	Ground
18	RinE2-	Receiver Signal (-)
19	RinE2+	Receiver Signal (+)
20	RinEC-	Clock Signal (-)
21	RinEC+	Clock Signal (+)
22	RinE3-	Receiver Signal (-)
23	RinE3+	Receiver Signal (+)
24	VSS	Ground
25	NC	NC
26	NC	NC
27	NC	NC
28	VDD+5V	Power Supply, 5V (Typical)
29	VDD+5V	Power Supply, 5V (Typical)
30	VDD+5V	Power Supply, 5V (Typical)

### 5.2 Back-Light Unit

CN3, 4: CCFL Power Source (BDBR-03(4.0)V-1S or equivalent)

Mating connector: SM02(8.0)B-BDBS-1-TB(CF)(SN) or equivalent

Terminal No.	Symbol	Function
1	VL	CCFL power supply (high voltage)
2	NC	No connection
3	GL	CCFL power supply (low voltage)

The information contained in this document is the exclusive property of HannStar Display Corporation. It shall not be disclosed, distributed or reproduced in whole or in part without written permission of HannStar Display Corporation.

Document Title	HSD170MGW1-B Formal Specification	Page No.	15 / 30
Document No.		Revision	1.0

## 6.0 ELECTRICAL CHARACTERISTICS

### 6.1 TFT LCD Module

Item	Symbol	Min.	Typ.	Max.	Unit	Note	
Voltage of power supply	$V_{DD}$	4.5	5.0	5.5	V		
Current of power supply	White	$I_{DD0}$	310	410	510	mA	(1)
	V-Color	$I_{DD1}$	380	480	580	mA	(1)
	Mosaic	$I_{DD2}$	510	610	710	mA	(1)
Vsync frequency	$f_V$	56	60	75	Hz	ref 6.5 t1	
Hsync frequency	$f_H$	55.469	55.935	70.635	KHz	ref 6.5 t4	
Frequency	$f_{DCLK}$	44.375	53.25	68.375	MHz	ref 6.5 t7	
Input rush current	$I_{Rush}$	-	-	1.5	A	(2)	

Note (1)

1). White & V- Color:

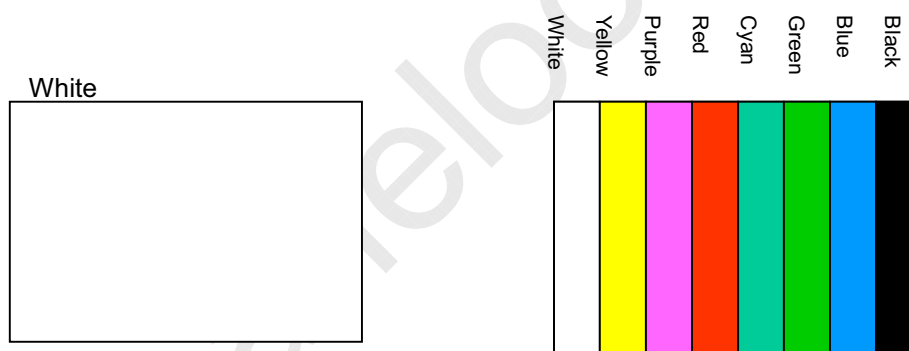

2). Mosaic: Dot checker image

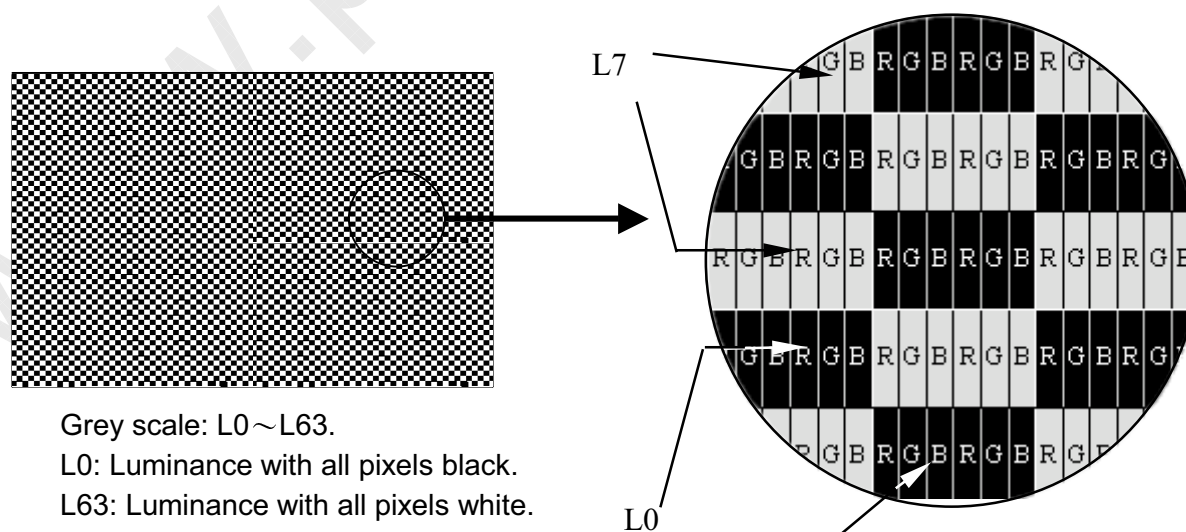

The information contained in this document is the exclusive property of HannStar Display Corporation. It shall not be disclosed, distributed or reproduced in whole or in part without written permission of HannStar Display Corporation.

Document Title	HSD170MGW1-B Formal Specification	Page No.	16 / 30
Document No.		Revision	1.0

### Note (2) Input Rush Current measurement condition

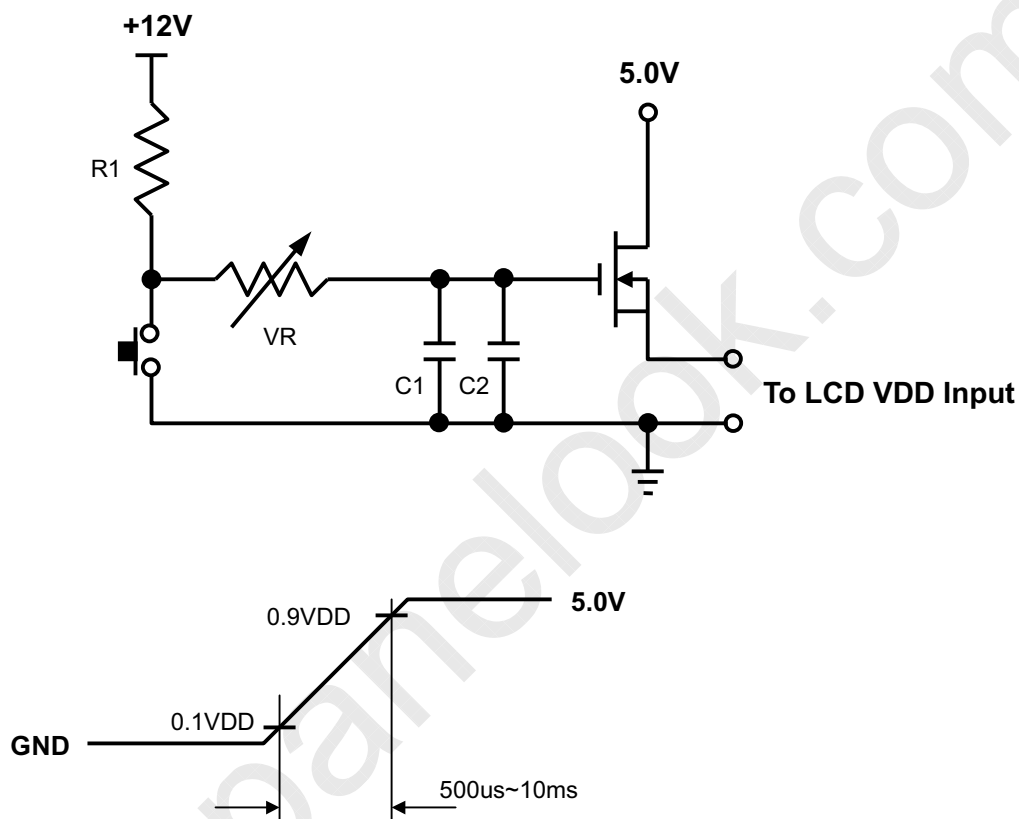



Document Title	HSD170MGW1-B Formal Specification	Page No.	17 / 30
Document No.		Revision	1.0

## 6.2 Back-Light Unit

The back- light system is an edge-lighting type with 2 CCFL.

The characteristic of the lamp is shown in the following tables.

Item	Symbol	Min.	Typ.	Max.	Unit	Note
Lamp current	IL	3.0	7.5	8.0	mA(rms)	(1)(6)
Lamp voltage	VL	589.5	655	769.5	V(rms)	(6) $I_L=7.5mA$
Frequency	fL	40	50	60	KHz	(2)
Operating lamp life time	Hr	40,000	-	-	Hour	(3) $I_L=7.5mA$
Startup voltage	Vs	1200	-	-	V(rms)	(4)(5) at 25°C
		1400				(4)(5) at 0°C

Note (1) Lamp current is measured with current meter for high frequency as shown below. Specified valued are for single lamp.

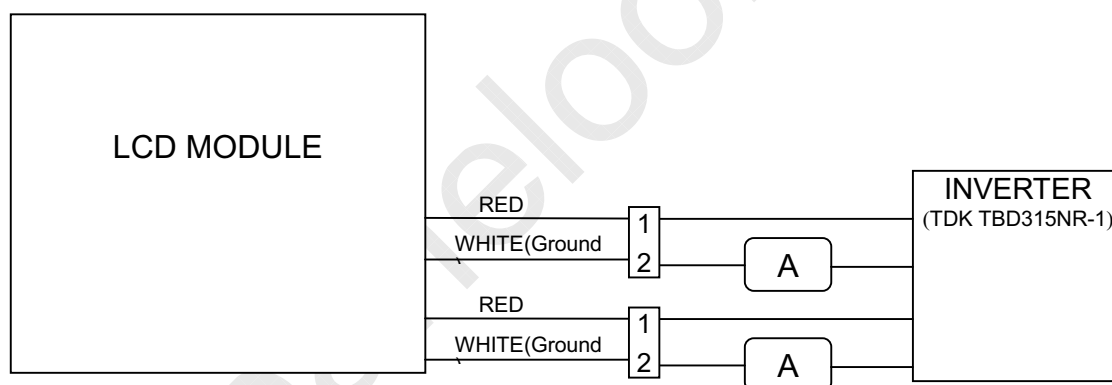

Note (2) Lamp frequency may produce interference with horizontal synchronous frequency and this may cause ripple noise on the display. Therefore lamp frequency shall be kept away from the horizontal synchronous frequency and its harmonics as far as possible in order to avoid interference.

\*Suggest the inverter frequency avoid  $f_L=41\sim 49KHz$

Note (3) Lamp life time (Hr) can be defined as the time in which it continues to operate under the condition:  $T_a=25\pm 3^\circ C$ , typical  $I_L$  value indicated in the above table until the brightness becomes less than 50%.

Note (4) CCFL inverter should be able to provide a voltage over specified value ( $V_s$ ) in the above table. Lamp units need at least  $V_s$  value shown above to ignition.

Note (5) The voltage over specified value ( $V_s$ ) should be applied to the lamp more than 1 second after startup. Otherwise, the lamp may not be turned on. The used lamp current is the lamp typical current.

Document Title	HSD170MGW1-B Formal Specification	Page No.	18 / 30
Document No.		Revision	1.0

Note (6) The output voltage waveform and current waveform of the inverter must be symmetrical (Unsymmetrical ratio is less than 10%). Please do not use the inverter which has unsymmetrical voltage and current waveform, and spike waveform. The inverter design which can provide the best optical performance, power efficiency, and lamp life should under the following conditions.

- The asymmetry rate of the inverter waveform should be less than 10%.
- The distortion rate of the waveform should be within  $\sqrt{2} \pm 10\%$ .
- The inverter output waveform should be better similar to the ideal sine wave.

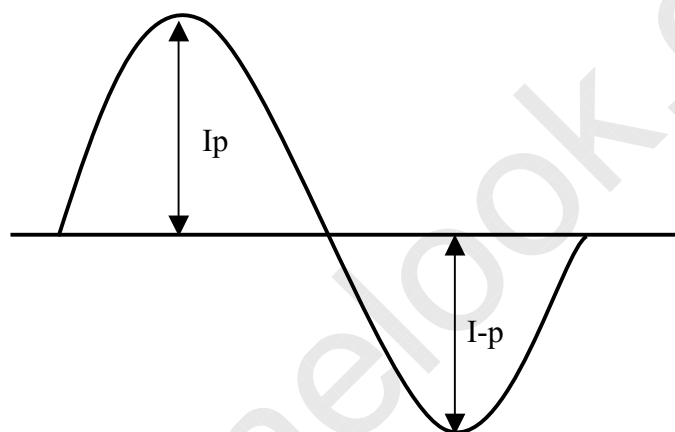

$$\text{Asymmetry rate} = |I_p - I_{-p}| / I_{\text{rms}} \times 100\%$$

$$\text{Distortion rate} = I_p \text{ (or } I_{-p}) / I_{\text{rms}}$$

Document Title	HSD170MGW1-B Formal Specification	Page No.	19 / 30
Document No.		Revision	1.0

### 6.3 Switching Characteristics for LVDS Receiver

Item	Symbol	Min.	Typ.	Max.	Unit	Conditions
Differential Input High Threshold	$V_{th}$	100	—	—	mV	$V_{CM}=1.2V$
Differential Input Low Threshold	$V_{tl}$	—	—	-100	mV	
Input Current	$I_{IN}$	—	—	$\pm 10$	$\mu A$	$V_{IN}=1.75V, V_{DD}=3.6V$
		—	—	$\pm 10$	$\mu A$	$V_{IN}=0.8V, V_{DD}=3.6V$
Input Voltage Range(Signal ended)	$V_{IN}$	$1.1-( V_{ID} )/2$	—	$1.375+( V_{ID} )/2$	V	
Differential input Voltage	$ V_{ID} $	250	—	450	mV	
Common Mode Voltage Offset	$V_{CM}$	1.1	—	1.375	V	
Clock Frequency	$f_c$	44.375	53.25	68.375	MHz	
LVDS Skew Margin	$t_{RSKM}$	—	—	400	pS	At $f_c=44.375MHz$
LVDS Input Clock Jitter Tolerance	—	—	—	$\pm 2.5$	%	center spread

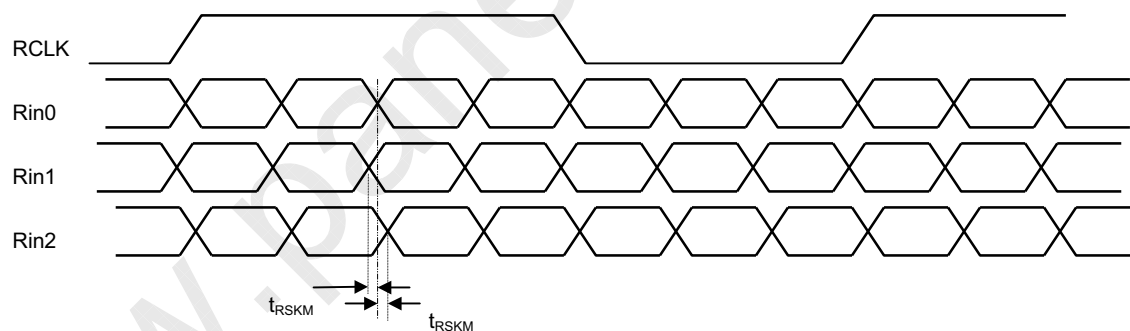

LVDS Receiver skew margin



HannStar Display Corp.

Document Title	HSD170MGW1-B Formal Specification	Page No.	20 / 30
Document No.		Revision	1.0

## 6.4 Bit Mapping & Interface Definition

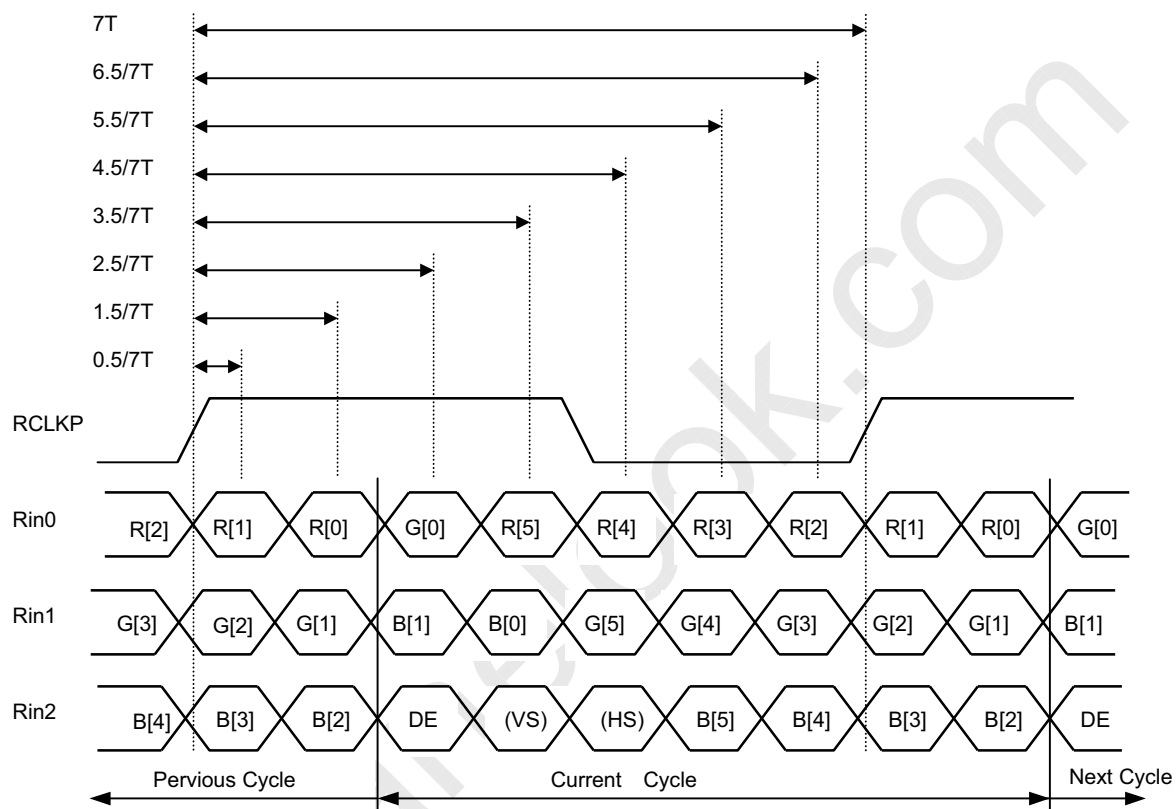

**Bit Mapping & Timing Definition**

The information contained in this document is the exclusive property of HannStar Display Corporation. It shall not be disclosed, distributed or reproduced in whole or in part without written permission of HannStar Display Corporation.

Document Title	HSD170MGW1-B Formal Specification	Page No.	21 / 30
Document No.		Revision	1.0

### 6.5 Interface Timing ( DE mode)

Item	Symbol	Min.	Typ.	Max.	Unit
Frame Rate	--	56	60	75	Hz
Frame Period	t1	910	934	1050	line
Vertical Display Time	t2	900	900	900	line
Vertical Blanking Time	t3	10	34	150	line
1 Line Scanning Time	t4	800	952	968	clock
Horizontal Display Time	t5	720	720	720	clock
Horizontal Blanking Time	t6	60	232	248	clock
Clock Rate	t7	44.375	53.25	68.375	MHz

### Timing Diagram of Interface Signal (DE mode)

#### (1) Vertical

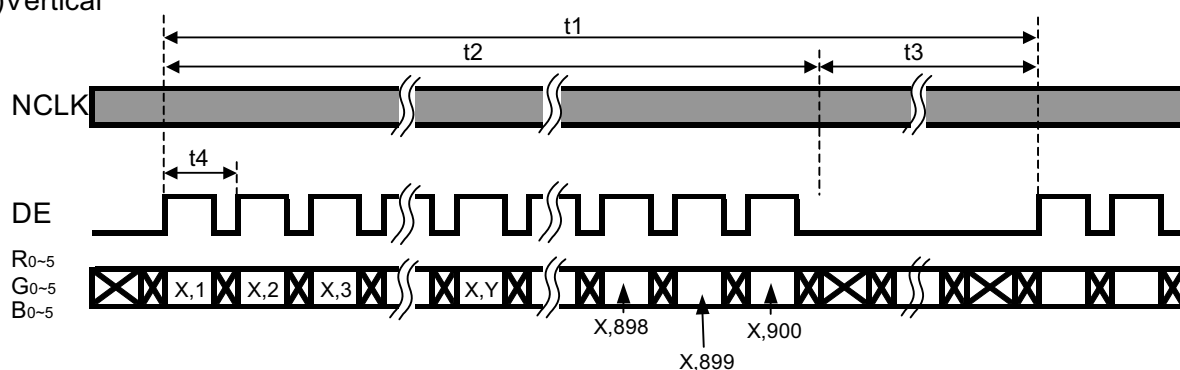

#### (2) Horizontal

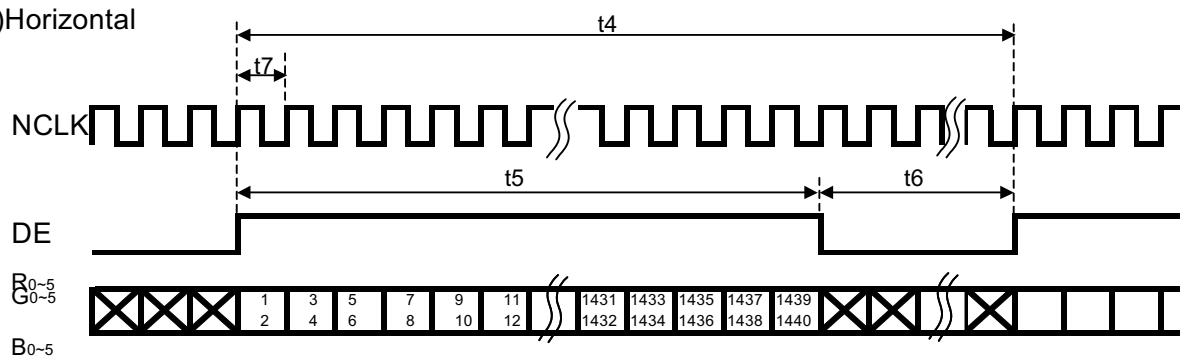

Document Title	HSD170MGW1-B Formal Specification	Page No.	22 / 30
Document No.		Revision	1.0

## 6.6 Power ON/OFF Sequence

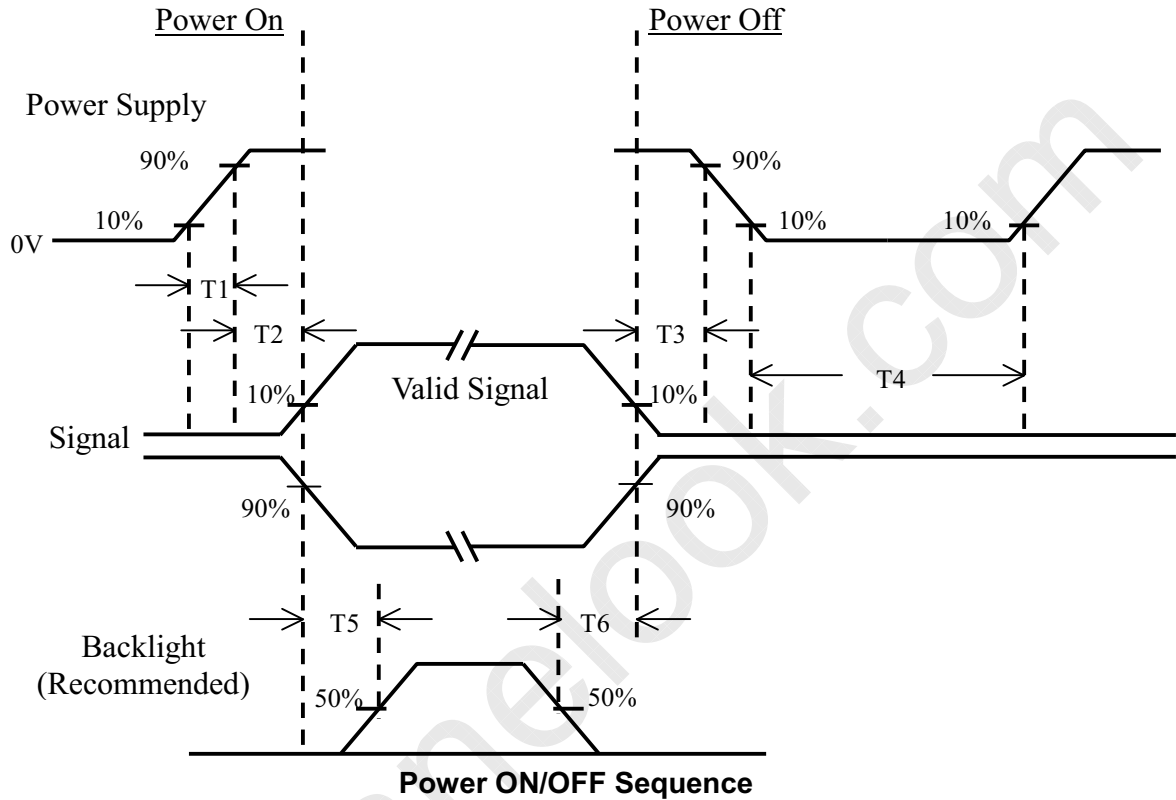

$$500 \text{ usec} < T1 \leq 10 \text{ msec}$$

$$0 < T2 \leq 50 \text{ msec}$$

$$0 < T3 \leq 50 \text{ msec}$$

$$200 \text{ ms} \leq T4$$

Back-light:

$$200 \text{ ms} \leq T5$$

$$200 \text{ msec} < T6$$

Note (1) Apply the lamp voltage within the LCD operation range. When the back-light turns on before the LCD operation or the LCD turns off before the back-light turns off, the display may momentarily become white.

(2) In case of  $V_{DD} = \text{off level}$ , please keep the level of input signal on 0 voltage.

(3) T4 should be measured after the module has been fully discharged between power off and on period.



HannStar Display Corp.

Document Title	HSD170MGW1-B Formal Specification	Page No.	23 / 30
Document No.		Revision	1.0

## 7.0 OUTLINE DIMENSION

### 7.1 Front View Outline Dimension

Unit : mm

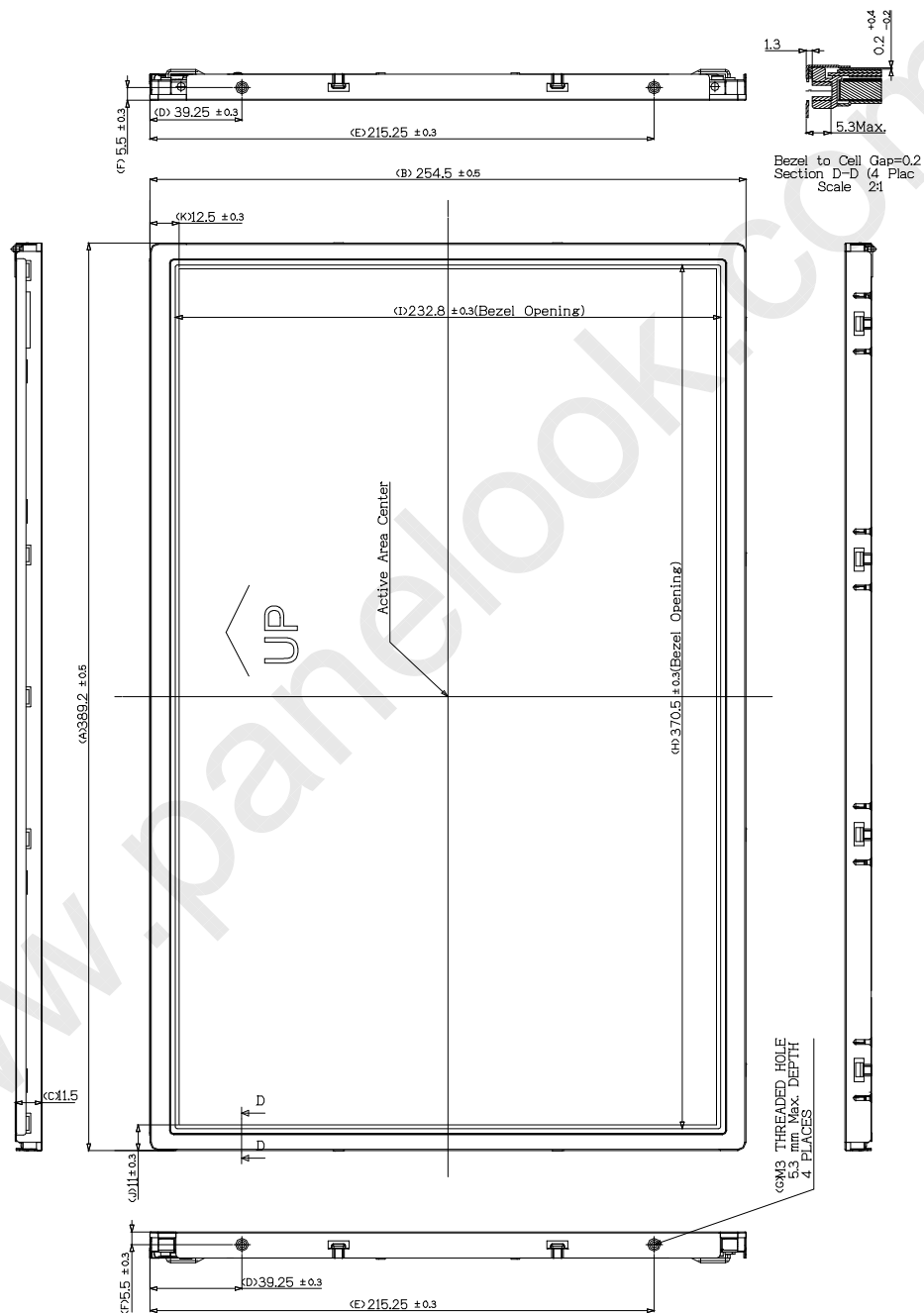

Note: Unspecified dimensional tolerance is +/-0.5mm

The information contained in this document is the exclusive property of HannStar Display Corporation. It shall not be disclosed, distributed or reproduced in whole or in part without written permission of HannStar Display Corporation.



HannStar Display Corp.

Document Title	HSD170MGW1-B Formal Specification	Page No.	24 / 30
Document No.		Revision	1.0

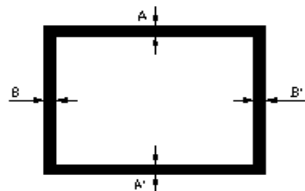

BM Assembly Tolerance

$$|A-A'| \leq 1 \text{ (mm)}$$

$$|B-B'| \leq 1 \text{ (mm)}$$

The information contained in this document is the exclusive property of HannStar Display Corporation. It shall not be disclosed, distributed or reproduced in whole or in part without written permission of HannStar Display Corporation.





HannStar Display Corp.

Document Title	HSD170MGW1-B Formal Specification	Page No.	25 / 30
Document No.		Revision	1.0

## 7.2 Back View Outline Dimension

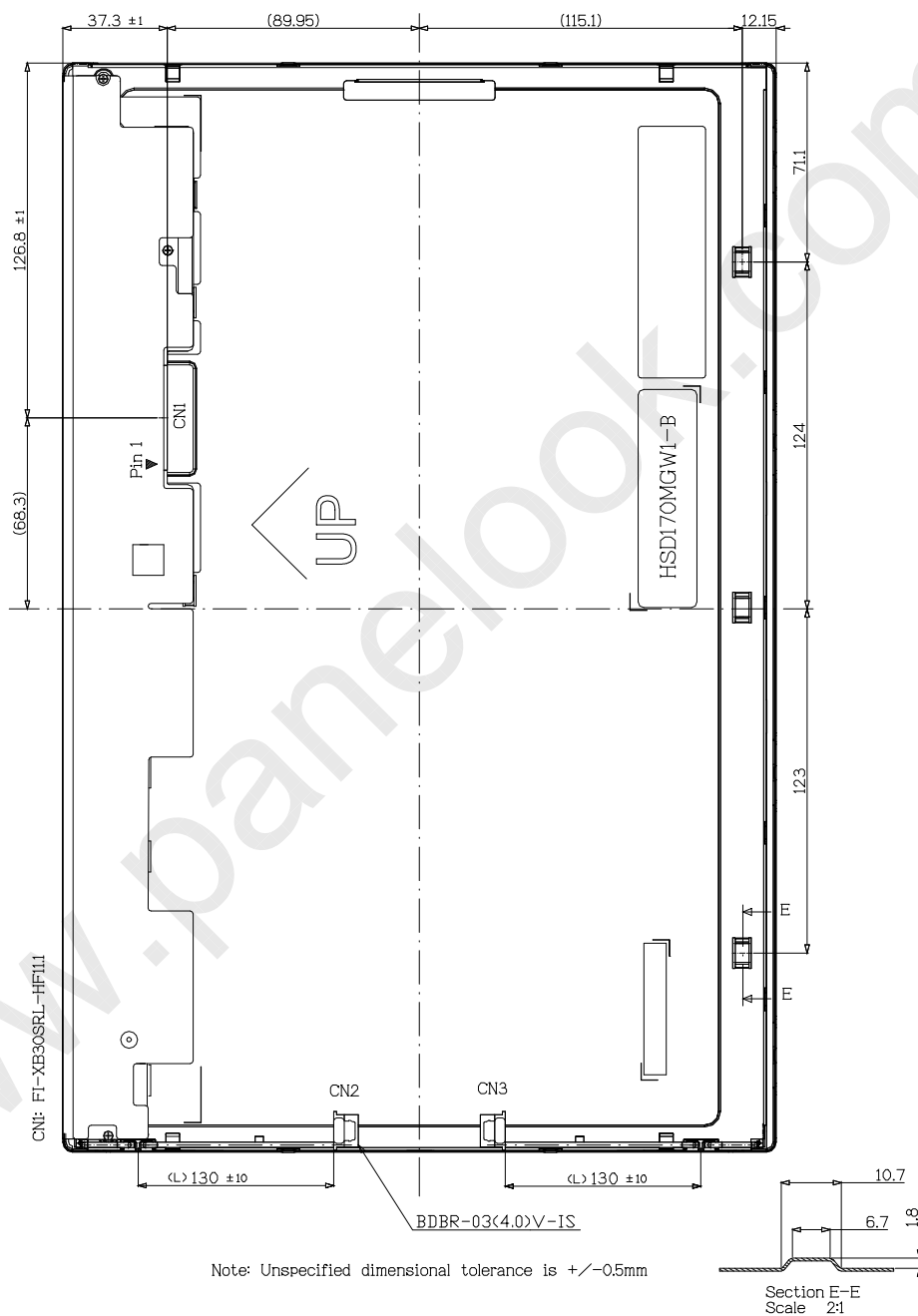

The information contained in this document is the exclusive property of HannStar Display Corporation. It shall not be disclosed, distributed or reproduced in whole or in part without written permission of HannStar Display Corporation.



HannStar Display Corp.

Document Title	HSD170MGW1-B Formal Specification	Page No.	26 / 30
Document No.		Revision	1.0

## 8.0 LOT MARK

### 8.1 Lot Mark

1	2	3	4	5	6	7	8	9	10	11	12	13	14	15
---	---	---	---	---	---	---	---	---	----	----	----	----	----	----

code 1,2,3,4,5,6: HannStar internal flow control code.

code 7: production location.

code 8: production year.

code 9: production month.

code 10,11,12,13,14,15: serial number.

#### Note (1) Production Year

Year	1999	2000	2001	2002	2003	2004	2005	2006	2007	2008
Mark	9	0	1	2	3	4	5	6	7	8

#### Note (2) Production Month

Month	Jan.	Feb.	Mar.	Apr.	May.	Jun.	Jul.	Aug.	Sep.	Oct.	Nov.	Dec.
Mark	1	2	3	4	5	6	7	8	9	A	B	C

### 8.2 Location of Lot Mark

(1) The label is attached to the backside of the LCD module.

(2) This is subject to change without prior notice.



The information contained in this document is the exclusive property of HannStar Display Corporation. It shall not be disclosed, distributed or reproduced in whole or in part without written permission of HannStar Display Corporation.



HannStar Display Corp.

Document Title	HSD170MGW1-B Formal Specification	Page No.	27 / 30
Document No.		Revision	1.0

## 9.0 PACKAGE SPECIFICATION

### 9.1 packing form

- (1) Package quantity in one carton: 10 pieces.
- (2) Carton size: 470 x 374 x 370H (mm)

### 9.2 packing assembly drawings

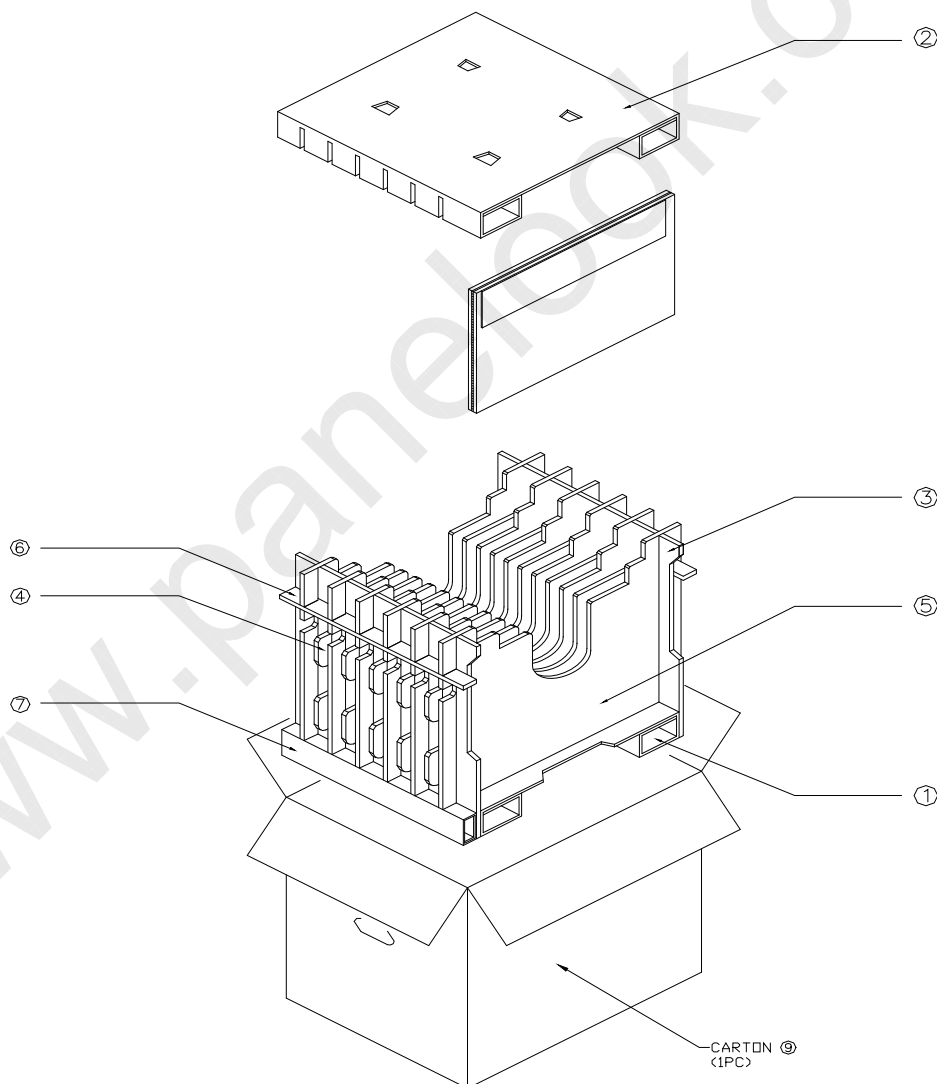

The information contained in this document is the exclusive property of HannStar Display Corporation. It shall not be disclosed, distributed or reproduced in whole or in part without written permission of HannStar Display Corporation.



HannStar Display Corp.

Document Title	HSD170MGW1-B Formal Specification	Page No.	28 / 30
Document No.		Revision	1.0

## 10.0 GENERAL PRECAUTION

### 10.1 Use Restriction

This product is not authorized for use in life supporting systems, aircraft navigation control systems, military systems and any other application where performance failure could be life-threatening or otherwise catastrophic.

### 10.2 Disassembling or Modification

Do not disassemble or modify the module. It may damage sensitive parts inside LCD module, and may cause scratches or dust on the display. HannStar does not warrant the module, if customers disassemble or modify the module.

### 10.3 Breakage of LCD Panel

- 10.3.1 If LCD panel is broken and liquid crystal spills out, do not ingest or inhale liquid crystal, and do not contact liquid crystal with skin.
- 10.3.2 If liquid crystal contacts mouth or eyes, rinse out with water immediately.
- 10.3.3 If liquid crystal contacts skin or cloths, wash it off immediately with alcohol and rinse thoroughly with water.
- 10.3.4 Handle carefully with chips of glass that may cause injury, when the glass is broken.

### 10.4 Electric Shock

- 10.4.1 Disconnect power supply before handling LCD module.
- 10.4.2 Do not pull or fold the CCFL cable.
- 10.4.3 Do not touch the parts inside LCD modules and the fluorescent lamp's connector or cables in order to prevent electric shock.

### 10.5 Absolute Maximum Ratings and Power Protection Circuit

- 10.5.1 Do not exceed the absolute maximum rating values, such as the supply voltage variation, input voltage variation, variation in parts' parameters, environmental temperature, etc., otherwise LCD module may be damaged.
- 10.5.2 Please do not leave LCD module in the environment of high humidity and high temperature for a long time.
- 10.5.3 It's recommended to employ protection circuit for power supply.

### 10.6 Operation

- 10.6.1 Do not touch, push or rub the polarizer with anything harder than HB pencil lead.
- 10.6.2 Use fingerstalls of soft gloves in order to keep clean display quality, when persons handle the LCD module for incoming inspection or assembly.
- 10.6.3 When the surface is dusty, please wipe gently with absorbent cotton or other soft material.

The information contained in this document is the exclusive property of HannStar Display Corporation. It shall not be disclosed, distributed or reproduced in whole or in part without written permission of HannStar Display Corporation.



HannStar Display Corp.

Document Title	HSD170MGW1-B Formal Specification	Page No.	29 / 30
Document No.		Revision	1.0

10.6.4 Wipe off saliva or water drops as soon as possible. If saliva or water drops contact with polarizer for a long time, they may causes deformation or color fading.

10.6.5 When cleaning the adhesives, please use absorbent cotton wetted with a little petroleum benzine or other adequate solvent.

### 10.7 Mechanism

Please mount LCD module by using mouting holes arranged in four corners tightly.

### 10.8 Static Electricity

10.8.1 Protection film must remove very slowly from the surface of LCD module to prevent from electrostatic occurrence.

10.8.2 Because LCD module use CMOS-IC on circuit board and TFT-LCD panel, it is very weak to electrostatic discharge. Please be careful with electrostatic discharge.

Persons who handle the module should be grounded through adequate methods.

### 10.9 Strong Light Exposure

The module shall not be exposed under strong light such as direct sunlight. Otherwise, display characteristics may be changed.

### 10.10 Disposal

When disposing LCD module, obey the local environmental regulations.