



Document Title	HSD173PUW1-A Formal Specification	Page No.	1/27
Document No.		Revision	1.0

HannStar Product Specification **(Formal)**

Model: HSD173PUW1
-A

- Note: (1) Please contact HannStar Display Corp. before designing your product based on this module specification.
- (2) The information contained herein is presented merely to indicate the characteristics and performance of our products. No responsibility is assumed by HannStar for any intellectual property claims or other problems that may result from application based on the module described herein.



Document Title	HSD173PUW1-A Formal Specification	Page No.	2/27
Document No.		Revision	1.0

Record of Revisions

Rev.	Date	Sub-Model	Description of change
1.0	--	A	Formal Product Specification was first released.



Document Title	HSD173PUW1-A Formal Specification	Page No.	3/27
Document No.		Revision	1.0

Contents

1.0	General description	p.4
2.0	Absolute maximum ratings.....	p.5
3.0	Optical characteristics.....	p.6
4.0	Block diagram	p.10
5.0	Interface pin connection	p.12
6.0	Electrical characteristics	p.13
7.0	Reliability test items	p.21
8.0	Outline dimension	p.22
9.0	Lot mark	p.24
10.0	Package specification	p.25
11.0	General precaution	p.26

Document Title	HSD173PUW1-A Formal Specification	Page No.	4/27
Document No.		Revision	1.0

1.0 GENERAL DESCRIPTION

1.1 Introduction

HannStar Display model HSD173PUW1-A is a color active matrix thin film transistor (TFT) liquid crystal display (LCD) that uses amorphous silicon TFT as a switching device. This model is composed of a TFT LCD panel, a driving circuit and a back light system. This TFT LCD has a 17.3 (16:9) inch diagonally measured active display area with Full HD (1920 horizontal by 1080 vertical pixel) resolution.

1.2 Features

- 17.3 (16:9 diagonal) inch configuration
- Two channel LVDS interface
- 262K color by 6 bit R.G.B signal input
- Color engine
- CABC
- RoHS Compliance
- Halogen Free

1.3 Applications

- NB

1.4 General information

Item	Specification	Unit
Outline Dimension	398.1 x 232.8 x 5.5 (Typ.)	mm
Display area	381.89(H) x 214.81(V)	mm
Number of Pixel	1920 RGB (H) x 1080(V)	pixels
Pixel pitch	0.1989(H) x 0.1989(V)	mm
Pixel arrangement	RGB Vertical stripe	
Display mode	Normally white	
NTSC	60	%
Surface treatment	Glare, Hard-Coating (3H)	
Weight	565 (Typ.)	g
Back-light	White LED	
Power Consumption	Logic System 1.6 (Max.)	W

Document Title	HSD173PUW1-A Formal Specification	Page No.	5/27
Document No.		Revision	1.0

1.5 Mechanical Information

Item		Min.	Typ.	Max.	Unit
Module Size	Horizontal (H)	397.6	398.1	368.6	mm
	Vertical (V)	232.3	232.8	233.3	mm
	Depth (D)	—	5.5	5.8	mm
Weight		—	565	580	g

2.0 ABSOLUTE MAXIMUM RATINGS

2.1 Electrical Absolute Rating

2.1.1 TFT LCD Module

Item	Symbol	Min.	Max.	Unit	Note
Logic Supply voltage	V_{DD}	-0.3	4.0	V	

2.1.2 Environment Absolute Rating

Item	Symbol	Min.	Max.	Unit	Note
Operating Temperature	T_{opa}	0	50	°C	
Storage Temperature	T_{stg}	-20	60	°C	

Document Title	HSD173PUW1-A Formal Specification	Page No.	6/27
Document No.		Revision	1.0

3.0 OPTICAL CHARACTERISTICS

3.1 Optical specification

Item	Symbol	Condition	Min.	Typ.	Max.	Unit	Note	
Contrast	CR	$\theta = 0$ Normal viewing angle	400	500	—		(1)(2)(4)	
Response time	Rising		Tr	—	2.4	4.8	msec	(1)(3)
	Falling		Tf	—	5.6	11.2		
White luminance (5 point)	Y_L			176	220	—	cd/m ²	(1)(4)(5) ($I_L=20mA$)
Color chromaticity (CIE1931)	Red		R_x	0.582	0.612	0.642		
			R_y	0.326	0.356	0.386		
	Green		G_x	0.293	0.323	0.353		
			G_y	0.564	0.594	0.624		
	Blue		B_x	0.118	0.148	0.178		
			B_y	0.062	0.092	0.122		
	White	W_x	0.283	0.313	0.343			
		W_y	0.299	0.329	0.359			
Viewing angle	Hor.	θ_L	70	80	—		(1)(4)	
		θ_R	70	80	—			
	Ver.	θ_U	50	60	—			
		θ_D	65	75	—			
Brightness uniformity	B_{UNI}	$\theta = 0$ (5point)	80	—	—	%	(6)	
Brightness Uniformity	B_{UNI}	$\theta = 0$ (13 points)	70	—	—	%	(6)	

3.2 Measuring Condition

- Measuring surrounding : dark room
- LED current I_L : 20mA / single LED
- Ambient temperature : 25±2°C
- 15min. warm-up time.

Document Title	HSD173PUW1-A Formal Specification	Page No.	7/27
Document No.		Revision	1.0

3.3 Measuring Equipment

- FPM520 of Westar Display technologies, INC., which utilized SR-3 for Chromaticity and BM-5A for other optical characteristics.

- Measuring spot size : 20 ~ 21 mm

Note (1) Definition of Viewing Angle:

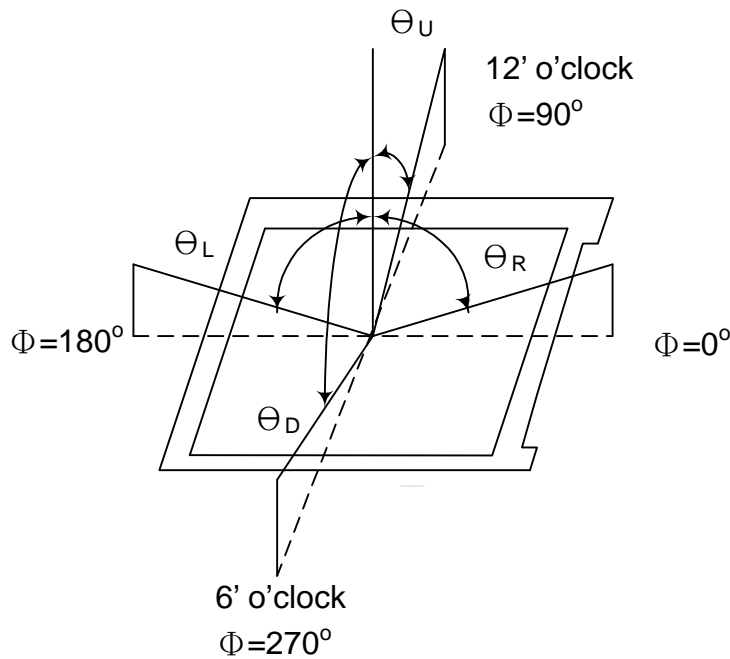

Note (2) Definition of Contrast Ratio (CR) :
measured at the center point of panel

$$CR = \frac{\text{Luminance with all pixels white}}{\text{Luminance with all pixels black}}$$

Document Title	HSD173PUW1-A Formal Specification	Page No.	8/27
Document No.		Revision	1.0

Note (3) Definition of Response Time : Sum of T_R and T_F

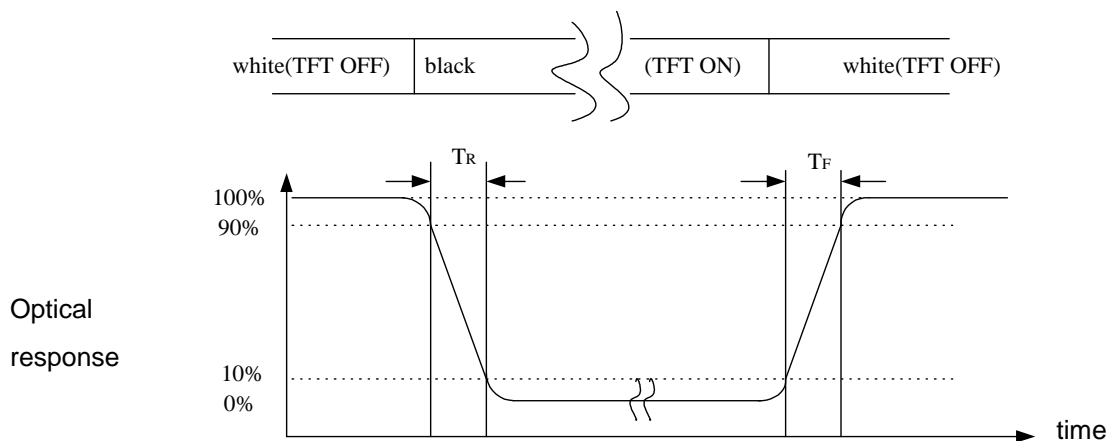

Note (4) Definition of optical measurement setup

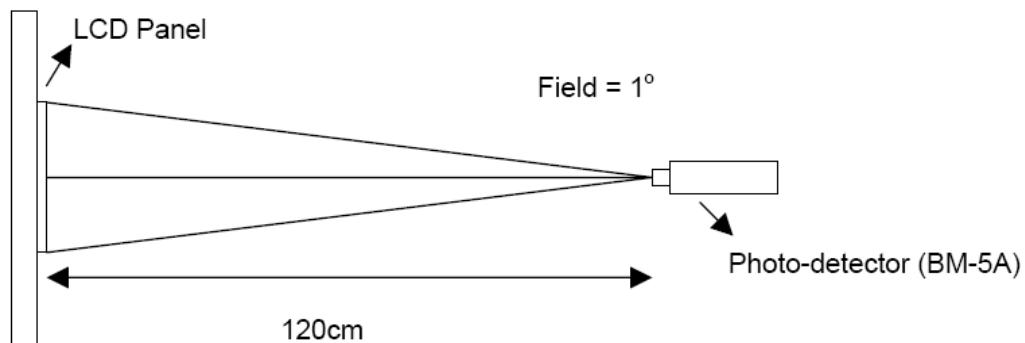

Document Title	HSD173PUW1-A Formal Specification	Page No.	9/27
Document No.		Revision	1.0

Note (5) Definition of Average Luminance Uniformity of White (5 Point)

$$\text{Average Luminance Uniformity} = \frac{Y_1+Y_2+Y_3+Y_4+Y_5}{5}$$

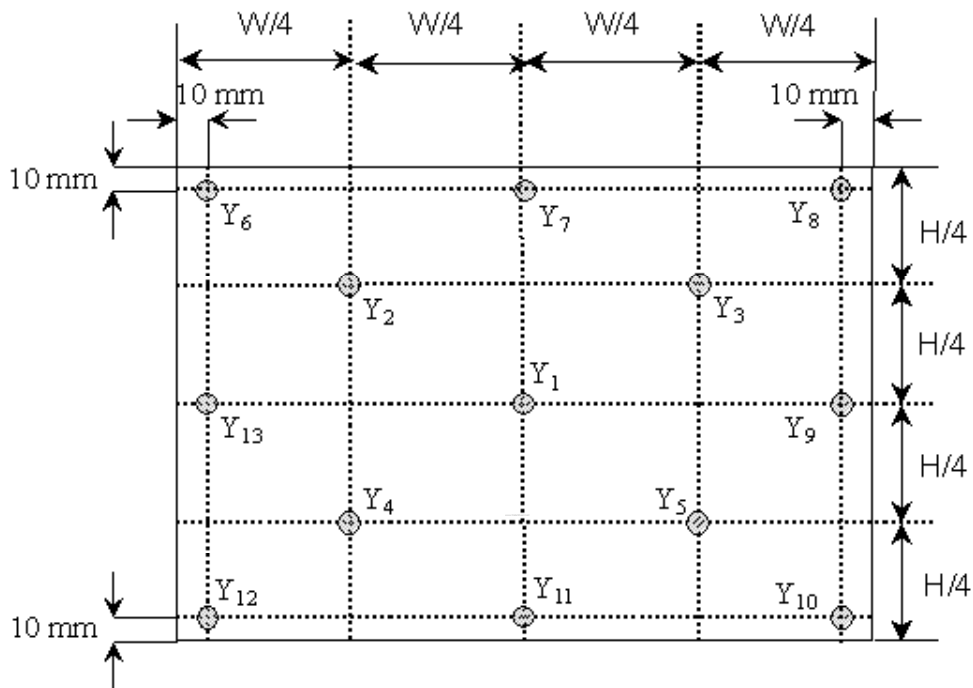

Note (6) Definition of brightness uniformity

$$\text{Luminance uniformity(5 points)} = \frac{(\text{Min Luminance of 5 points})}{(\text{Max Luminance of 5 points})} \times 100\%$$

$$\text{Luminance uniformity(13points)} = \frac{(\text{Min Luminance of 13 points})}{(\text{Max Luminance of 13 points})} \times 100\%$$

Document Title	HSD173PUW1-A Formal Specification	Page No.	10/27
Document No.		Revision	1.0

4.0 BLOCK DIAGRAM

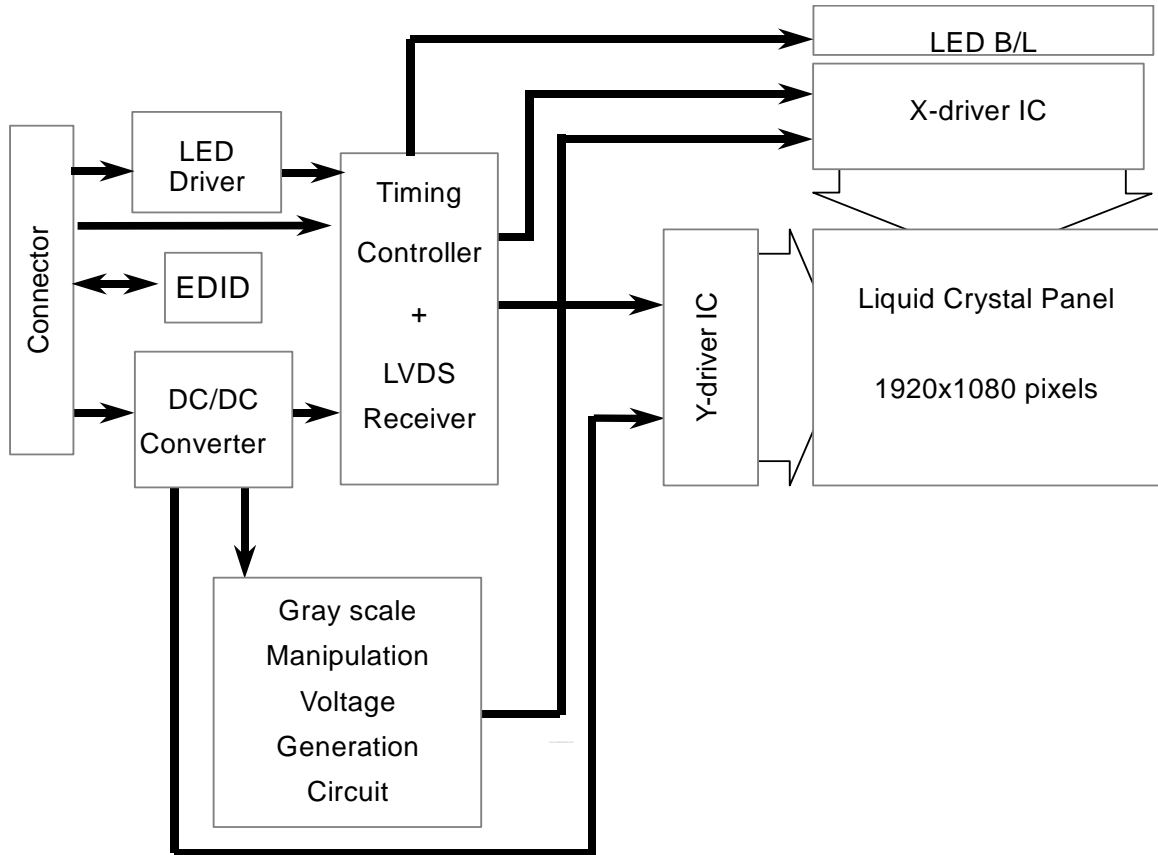

4.1 TFT LCD Module:

4.2 Pixel Format

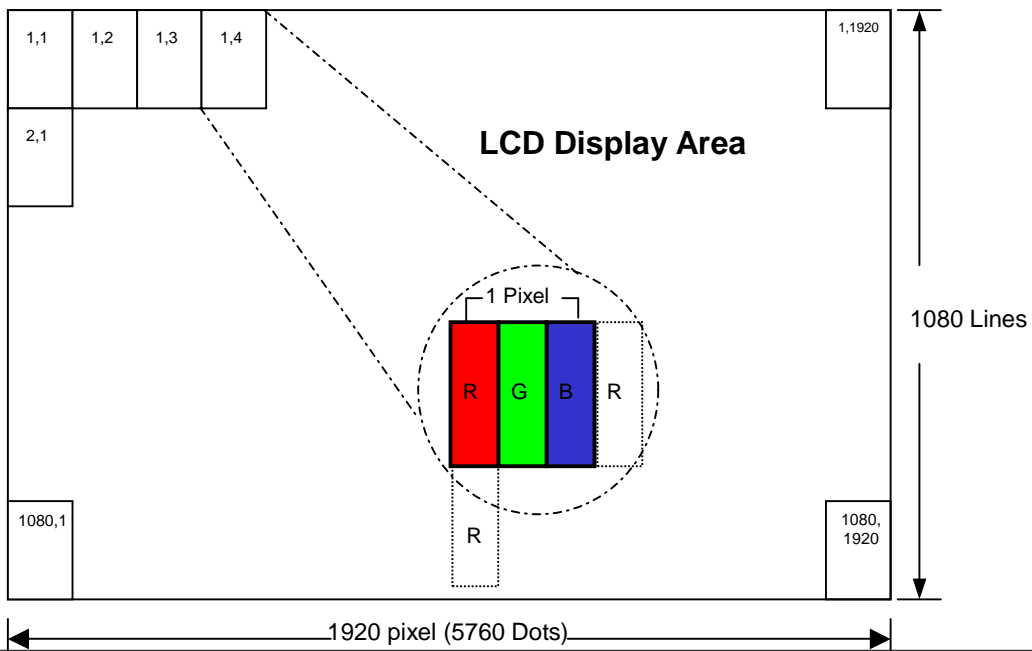

Document Title	HSD173PUW1-A Formal Specification	Page No.	11/27
Document No.		Revision	1.0

4.3 Relationship Between Displayed Color and Input

	Display	MSB						LSB						Gray scale level							
		R5	R4	R3	R2	R1	R0	G5	G4	G3	G2	G1	G0		B5	B4	B3	B2	B1	B0	
Basic color	Black	L	L	L	L	L	L	L	L	L	L	L	L	L	L	L	L	L	L	-	
	Blue	L	L	L	L	L	L	L	L	L	L	L	L	H	H	H	H	H	H	-	
	Green	L	L	L	L	L	L	H	H	H	H	H	H	L	L	L	L	L	L	-	
	Light Blue	L	L	L	L	L	L	H	H	H	H	H	H	H	H	H	H	H	H	-	
	Red	H	H	H	H	H	H	L	L	L	L	L	L	L	L	L	L	L	L	-	
	Purple	H	H	H	H	H	H	L	L	L	L	L	L	H	H	H	H	H	H	-	
	Yellow	H	H	H	H	H	H	H	H	H	H	H	H	L	L	L	L	L	L	-	
	White	H	H	H	H	H	H	H	H	H	H	H	H	H	H	H	H	H	H	-	
Gray scale of Red	Black	L	L	L	L	L	L	L	L	L	L	L	L	L	L	L	L	L	L	L0	
	Dark ↑ ↓ Light	L	L	L	L	L	H	L	L	L	L	L	L	L	L	L	L	L	L	L1	
		L	L	L	L	H	L	L	L	L	L	L	L	L	L	L	L	L	L	L2	
		⋮	⋮	⋮	⋮	⋮	⋮	⋮	⋮	⋮	⋮	⋮	⋮	⋮	⋮	⋮	⋮	⋮	⋮	⋮	L3...L60
		H	H	H	H	L	H	L	L	L	L	L	L	L	L	L	L	L	L	L61	
	H	H	H	H	H	L	L	L	L	L	L	L	L	L	L	L	L	L	L62		
	Red	H	H	H	H	H	H	L	L	L	L	L	L	L	L	L	L	L	L	Red L63	
	Gray scale of Green	Black	L	L	L	L	L	L	L	L	L	L	L	L	L	L	L	L	L	L	L0
Dark ↑ ↓ Light		L	L	L	L	L	L	L	L	L	L	L	H	L	L	L	L	L	L	L1	
		L	L	L	L	L	L	L	L	L	L	H	L	L	L	L	L	L	L	L2	
		⋮	⋮	⋮	⋮	⋮	⋮	⋮	⋮	⋮	⋮	⋮	⋮	⋮	⋮	⋮	⋮	⋮	⋮	⋮	L3...L60
		L	L	L	L	L	L	H	H	H	H	L	H	L	L	L	L	L	L	L61	
L		L	L	L	L	L	H	H	H	H	H	L	L	L	L	L	L	L	L62		
Green		L	L	L	L	L	L	H	H	H	H	H	H	L	L	L	L	L	Green L63		
Gray scale of Blue		Black	L	L	L	L	L	L	L	L	L	L	L	L	L	L	L	L	L	L	L0
	Dark ↑ ↓ Light	L	L	L	L	L	L	L	L	L	L	L	L	L	L	L	L	L	H	L1	
		L	L	L	L	L	L	L	L	L	L	L	L	L	L	L	L	H	L	L2	
		⋮	⋮	⋮	⋮	⋮	⋮	⋮	⋮	⋮	⋮	⋮	⋮	⋮	⋮	⋮	⋮	⋮	⋮	⋮	L3...L60
		L	L	L	L	L	L	L	L	L	L	L	L	H	H	H	H	L	H	L61	
	L	L	L	L	L	L	L	L	L	L	L	L	H	H	H	H	H	L	L62		
	Blue	L	L	L	L	L	L	L	L	L	L	L	L	H	H	H	H	H	Blue L63		
	Gray scale of White & Black	Black	L	L	L	L	L	L	L	L	L	L	L	L	L	L	L	L	L	L	L0
Dark ↑ ↓ Light		L	L	L	L	L	H	L	L	L	L	L	H	L	L	L	L	L	H	L1	
		L	L	L	L	H	L	L	L	L	L	H	L	L	L	L	L	H	L	L2	
		⋮	⋮	⋮	⋮	⋮	⋮	⋮	⋮	⋮	⋮	⋮	⋮	⋮	⋮	⋮	⋮	⋮	⋮	⋮	L3...L60
		H	H	H	H	L	H	H	H	H	H	L	H	H	H	H	H	L	H	L61	
H		H	H	H	H	L	H	H	H	H	H	L	H	H	H	H	H	L	L62		
White	H	H	H	H	H	H	H	H	H	H	H	H	H	H	H	H	H	White L63			

Document Title	HSD173PUW1-A Formal Specification	Page No.	12/27
Document No.		Revision	1.0

5.0 INTERFACE PIN CONNECTION

5.1 TFT LCD Module : CN1 (Input signal): IPEX 20455-040E-12 (IPEX or equivalent)

Pin No.	Signal	Description
1	COLOR_EN	Color Engine Enable Default 0 : Disable
2	VCC	3.3V Power Supply
3	VCC	3.3V Power Supply
4	V_EDID	EDID 3.3V Power Supply
5	CABC_EN	CABC Enable Default 1 : Disable
6	CLK_EDID	EDID Clock
7	DATA_EDID	EDID Data
8	RxOIN0-	-LVDS Differential Data Input (Odd R0-R5,G0)
9	RxOIN0+	+LVDS Differential Data Input (Odd R0-R5,G0)
10	GND	Ground
11	RxOIN1-	- LVDS differential data input(Odd G1-G5,B0-B1)
12	RxOIN1+	+LVDS differential data input(Odd G1-G5,B0-B1)
13	GND	Ground
14	RxOIN2-	- LVDS differential data input (Odd B2-B5,HS,VS,DE)
15	RxOIN2+	+LVDS differential data input (Odd B2-B5,HS,VS,DE)
16	GND	Ground
17	RxOCLKIN-	-LVDS differential clock input(Odd)
18	RxOCLKIN+	+LVDS differential clock input(Odd)
19	GND	Ground
20	RxEIN0-	- LVDS differential data input (Even R0-R5,G0)
21	RxEIN0+	+LVDS differential data input (Even R0-R5,G0)
22	GND	Ground-Shield
23	RxEIN1-	- LVDS differential data input (Even G1-G5,B0-B1)
24	RxEIN1+	+LVDS differential data input (Even G1-G5,B0-B1)
25	GND	Ground-Shield
26	RxEIN2-	- LVDS differential data input (Even B2-B5,HS,VS,DE)
27	RxEIN2+	+LVDS differential data input (Even B2-B5,HS,VS,DE)
28	GND	Ground-Shield
29	RxECLKIN-	-LVDS differential clock input(Even)
30	RxECLKIN+	+LVDS differential clock input(Even)
31	VLED_GND	LED Ground
32	VLED_GND	LED Ground
33	VLED_GND	LED Ground
34	NC	No Connection
35	PWM	PWM Signal for LED dimming control
36	LED_EN	LED Enable Pin (+3V Input)
37	NC	No Connection
38	VLED	LED Power Supply 7-21V
39	VLED	LED Power Supply 7-21V
40	VLED	LED Power Supply 7-21V

Note : The brightness of LCD panel could be changed by adjusting PWM

Document Title	HSD173PUW1-A Formal Specification	Page No.	13/27
Document No.		Revision	1.0

6.0 ELECTRICAL CHARACTERISTICS

6.1 TFT LCD Module

Item	Symbol	Min.	Typ.	Max.	Unit	Note
Supply Voltage	V_{DD}	3.0	3.3	3.6	V	Note (1)
Current of power supply	I_{DD}	-	0.4	-	A	$V_{DD} = 3.3V$ · L0 pattern
Inrush current	I_{RUSH}	-	-	3.0	A	Note (2)

Note (1): V_{DD} -dip condition:

When V_{DD} operating within $2.7V \leq V_{DD} < 3.0V$, $t_d \leq 10ms$, the display may momentarily become abnormal.

$V_{DD} < 2.7V$, V_{DD} dip condition should also follow the Power On/Off conditions for supply voltage.

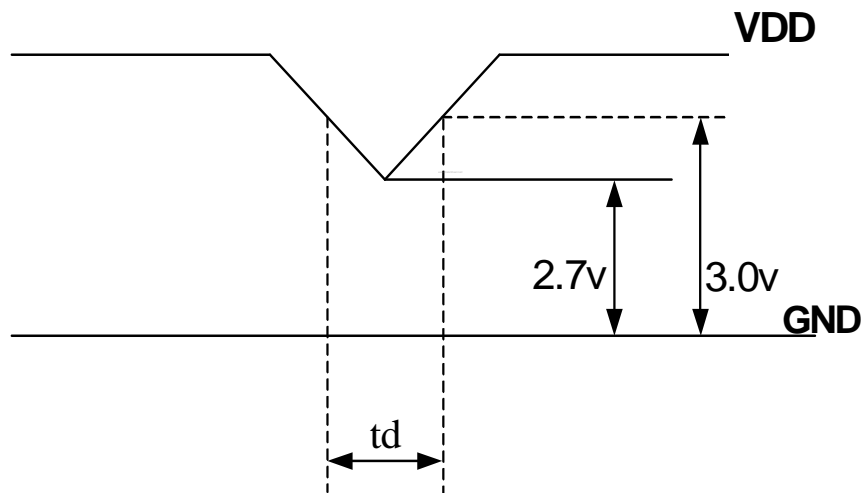

Document Title	HSD173PUW1-A Formal Specification	Page No.	14/27
Document No.		Revision	1.0

Note : (2) Power on Inrush current test circuit

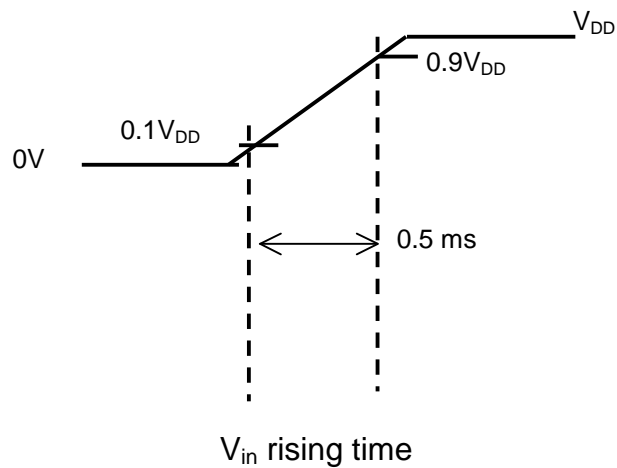
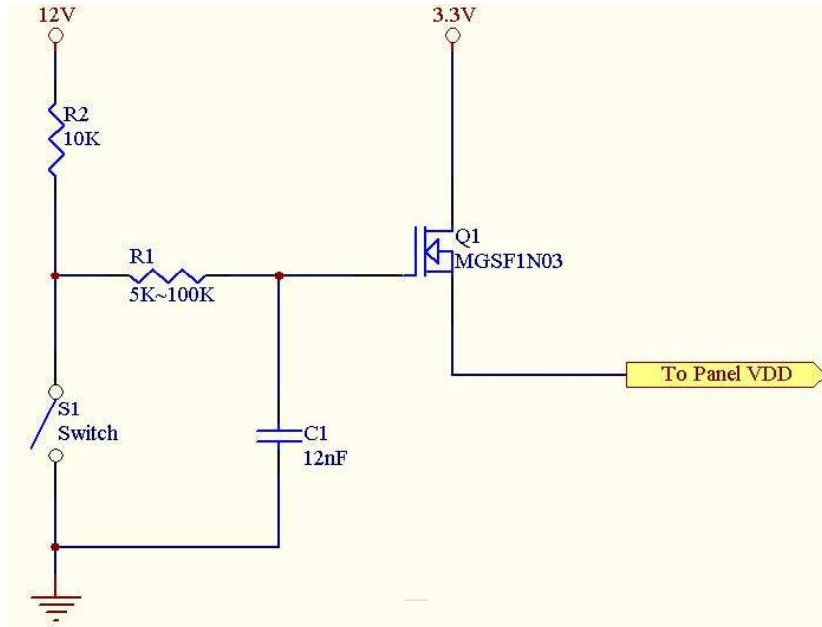

Document Title	HSD173PUW1-A Formal Specification	Page No.	15/27
Document No.		Revision	1.0

6.2 Switching Characteristics for LVDS Receiver

Item	Symbol	Min.	Typ.	Max.	Unit	Conditions
Differential Input High Threshold	V _{th}	—	—	100	mV	V _{CM} =1.2V
Differential Input Low Threshold	V _{tl}	-100	—	—	mV	
Input Current	I _{IN}	-10	—	+10	uA	
Differential input Voltage	V _{ID}	0.2	—	0.6	V	
Common Mode Voltage Offset	V _{CM}	(V _{ID} /2)	1.2	2.25-(V _{ID} /2)	V	

6.3 Bit Mapping & Interface Definition

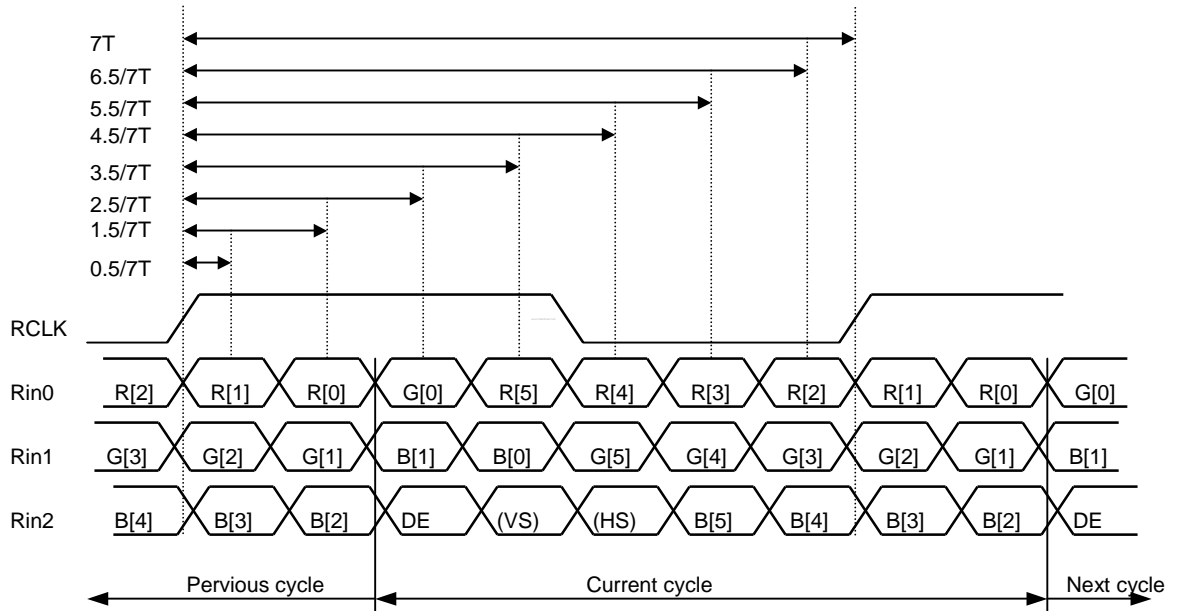

LVDS Receiver Input Timing Definition
for 6bits LVDS input

Document Title	HSD173PUW1-A Formal Specification	Page No.	16/27
Document No.		Revision	1.0

6.4 Interface Timing (DE mode)

Item	Symbol	Min.	Typ.	Max.	Unit
Frame Rate	--	55	60	65	Hz
Frame Period	t1	1088	1096	1104	line
Vertical Display Time	t2	1080	1080	1080	line
Vertical Blanking Time	t3	8	16	24	line
1 Line Scanning Time	t4	1000	1008	1184	clock
Horizontal Display Time	t5	960	960	960	clock
Horizontal Blanking Time	t6	40	48	224	clock
Clock Rate	t7	59.85	66.30	85.00	MHz

Timing Diagram of Interface Signal (DE mode)

(1) Vertical

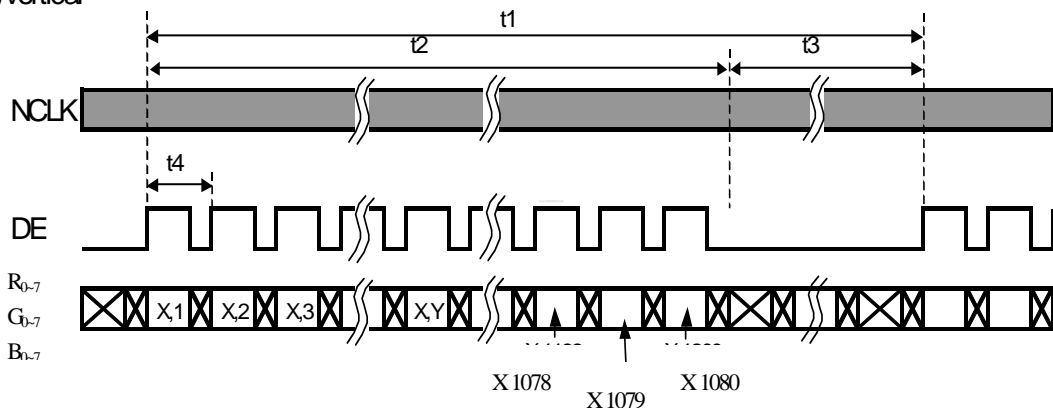

(2) Horizontal

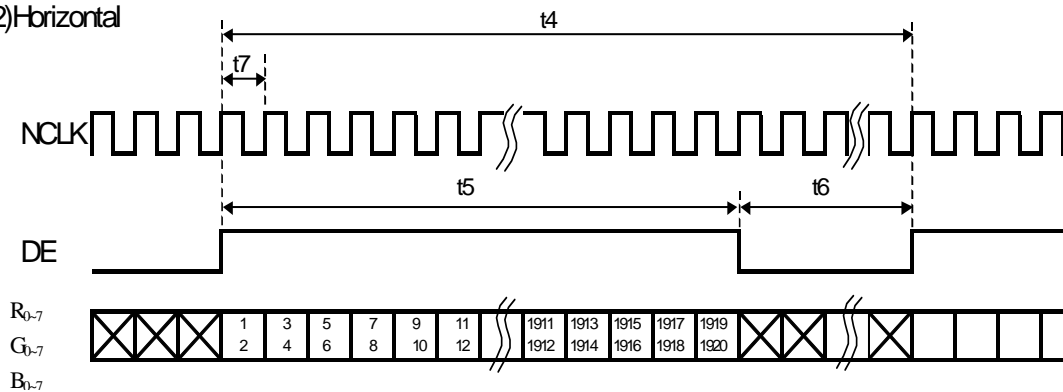

Document Title	HSD173PUW1-A Formal Specification	Page No.	17/27
Document No.		Revision	1.0

6.5 Power On / Off Sequence

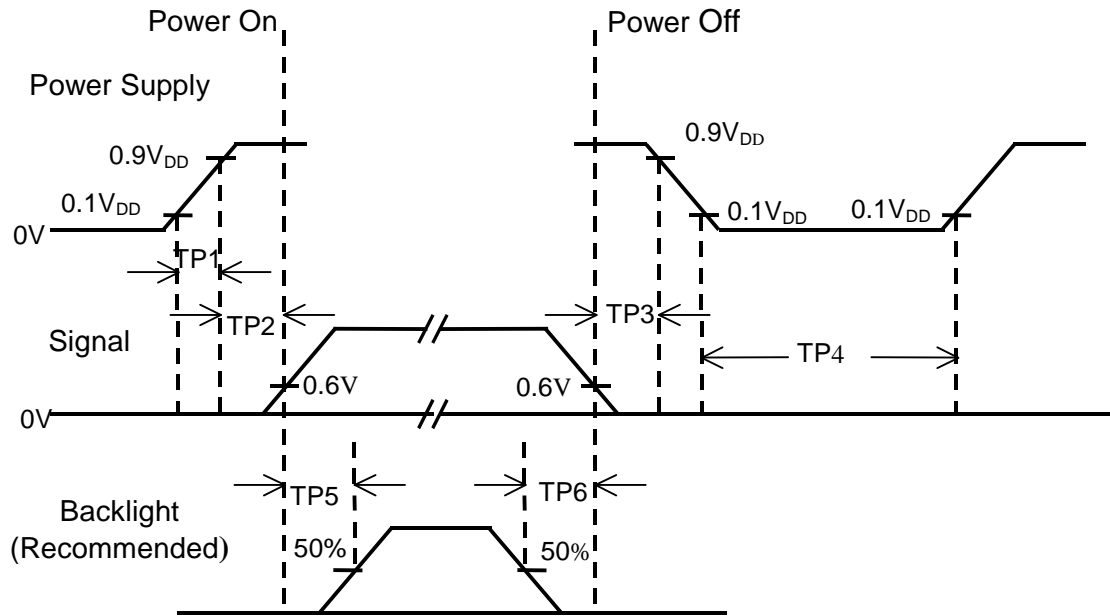

Item	Min.	Typ.	Max.	Unit	Remark
TP1	0.5	--	10	msec	
TP2	0.01	--	50	msec	
TP3	20	35	50	msec	
TP4	1000	--	--	msec	
TP5	200	--	--	msec	
TP6	200	--	--	msec	

- Note :**
- (1) The supply voltage of the external system for the module input should be the same as the definition of V_{DD}.
 - (2) Apply the lamp voltage within the LCD operation range. When the back-light turns on before the LCD operation or the LCD turns off before the back-light turns off, the display may momentarily become white.
 - (3) In case of V_{DD} = off level, please keep the level of input signal on the low or keep a high impedance.
 - (4) TP4 should be measured after the module has been fully discharged between power off and on period.
 - (5) Interface signal shall not be kept at high impedance when the power is on.

Document Title	HSD173PUW1-A Formal Specification	Page No.	18/27
Document No.		Revision	1.0

6.6 Backlight Unit

Parameter	Symbol	Min	Typ	Max	Units	Condition
LED Current	I_F	--	20	20.6	mA	Ta=25°C
LED Voltage	V_F	3.0	3.2	3.4	Volt	Ta=25°C
LED Power consumption	P_{LED}	--	4.61	5.05	Watt	Ta=25°C Note (1)
LED Life-Time	N/A	10,000	--	--	Hour	Ta=25°C $I_F=20mA$ Note (2)

Note (1): Calculator value for reference $P=I_F \times V_F \times N$ (LED Qty')

Note (2): The LED lifetime defines as the estimated time to 50% degradation of final luminous.

6.7 LED Driver

6.7.1 Absolute Maximum Ratings

Item	Symbol	Min.	Max.	Unit	Note
LED Power Supply voltage	V_{LED}	-0.3	24	Volt	
LED_EN, PWM pin Voltage	V_{EN}, V_{PWM}	--	3.6	Volt	

6.7.2 DC Electrical Characteristics

Parameter	Symbol	Min	Typ	Max	Units
LED Power Supply Voltage	V_{LED}	7.0	--	21.0	Volt
LED_EN High Threshold	V_{ENH}	2.0	--	--	Volt
LED_EN Low Threshold	V_{ENL}	--	--	0.3	Volt
PWM High Threshold	V_{PWMH}	3.0	--	--	Volt
PWM Low Threshold	V_{PWML}	--	--	0.2	Volt
PWM Frequency	F_{PWM}	225	250	275	Hz
PWM Duty Cycle	T_D	10	--	100	%

Document Title	HSD173PUW1-A Formal Specification	Page No.	19/27
Document No.		Revision	1.0

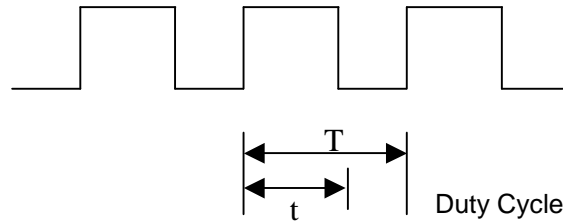

6.7.3 LED Power on/off sequence

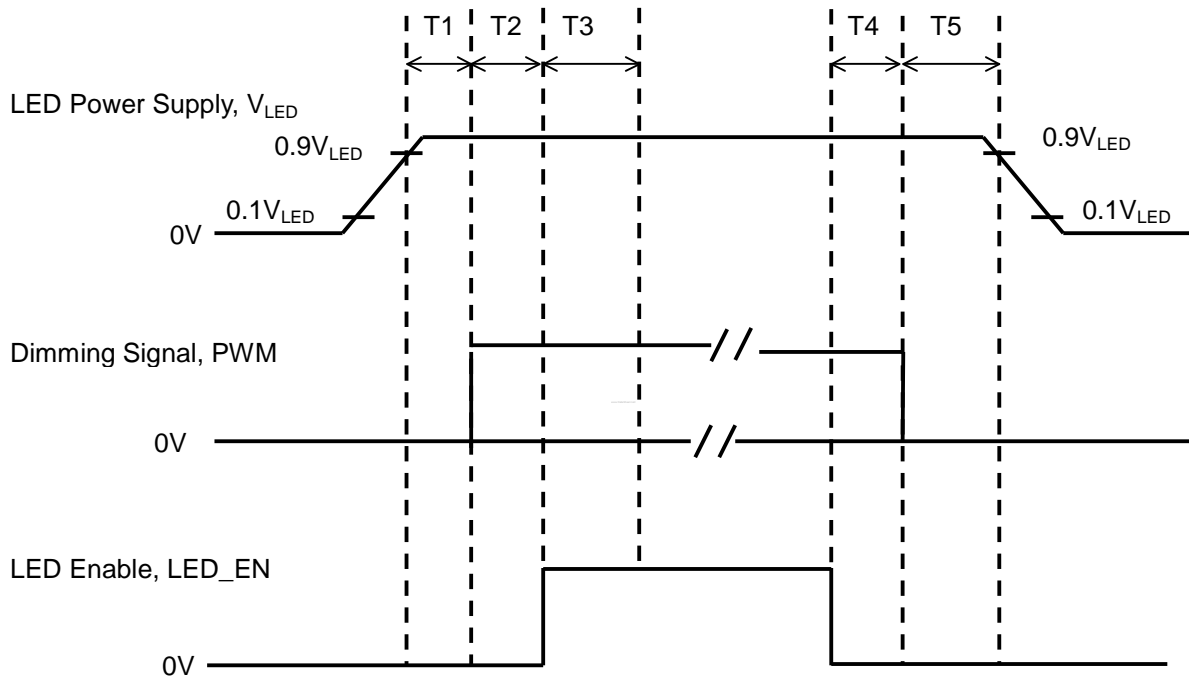

Symbol	Value			Unit
	Min	Typ	Max	
T1	10	--	--	ms
T2	10	--	--	
T3	50	--	--	
T4	0	--	--	
T5	10	--	--	

Note (1): The duty of LED dimming signal should be more than 20% in T2 and T3

Note (2): PWM can adjust brightness to control Pin. Pulse duty the bigger the brighter.



Document Title	HSD173PUW1-A Formal Specification	Page No.	20/27
Document No.		Revision	1.0

6.8 Color Engine and CABC DC Electrical Characteristics

Parameter	Symbol	Min	Typ	Max	Units	Remark
COLOR_EN High Threshold	V_{COLH}	$0.7V_{DD}$	--	--	Volt	
COLOR_EN Low Threshold	V_{COLL}	--	--	$0.3V_{DD}$	Volt	
CABC_EN High Threshold	V_{CABCH}	$0.7V_{DD}$	--	--	Volt	
CABC_EN Low Threshold	V_{CABCL}	--	--	$0.3V_{DD}$	Volt	

Document Title	HSD173PUW1-A Formal Specification	Page No.	21/27
Document No.		Revision	1.0

7.0 Reliability test items

No.	Item	Conditions	Remark
1	High Temperature Storage	Ta=+60°C, 240hrs	
2	Low Temperature Storage	Ta=-20°C, 240hrs	
3	High Temperature Operation	Ta=+50°C, 500hrs	
4	Low Temperature Operation	Ta=0°C, 500hrs	
5	Thermal Cycling Test (non operation)	-20°C(30min)→+60°C(30min),100 cycles	
6	Vibration	Sine Wave 1.5G, 5~500Hz, XYZ 30min/each direction	
7	Shock	Half-Sine, 200G, 2ms, ±XYZ, 1time	

Storage / Operating temperature

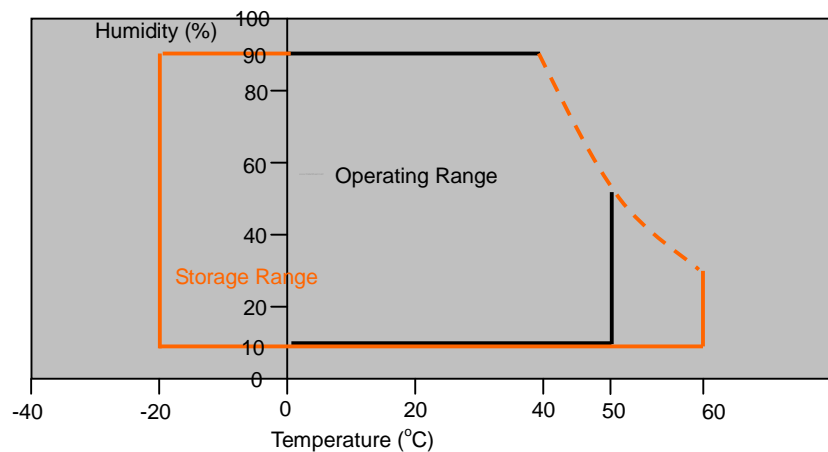

Note .Max wet bulb temp.=39°C

Document Title	HSD173PUW1-A Formal Specification	Page No.	22/27
Document No.		Revision	1.0

8.0 OUTLINE DIMENSION

8.1 Front View Outline Dimension

Unit : mm

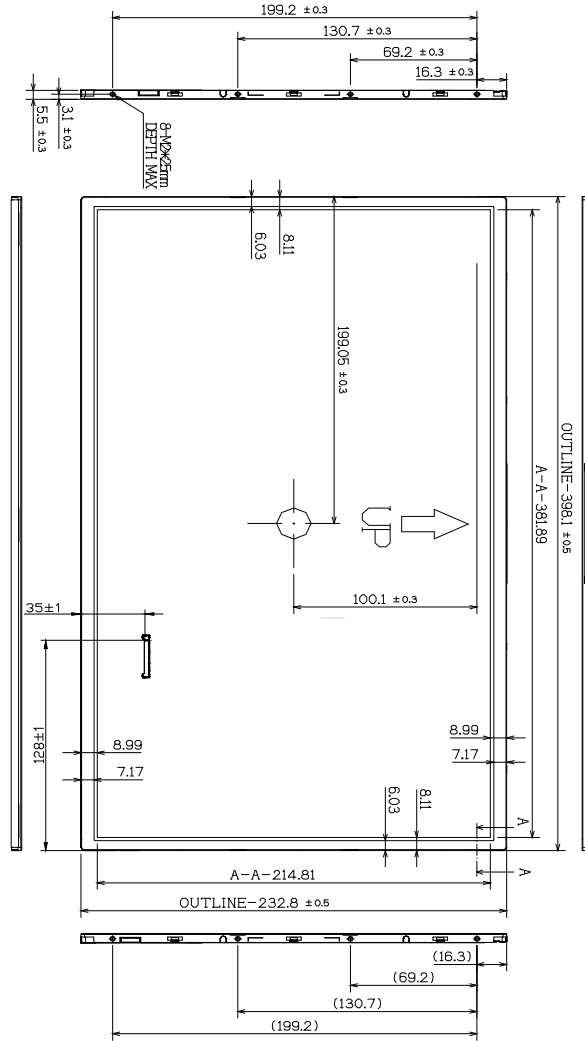

NOTE
 Model : HSD173PUW1-A
 Outline : 398.1±0.5mm(398.1±0.5mm)
 Position : 8.11mm(8.11mm) depth 25mm-max
 General tolerance : ±0.2mm
 5 1/4" connector
 part 20465-04E-12 or equivalent
 laser mounting torque spec : 25kgf-cm
 7unit : mm

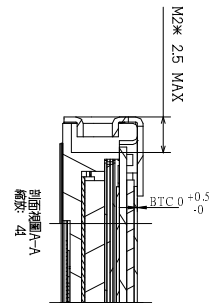

Document Title	HSD173PUW1-A Formal Specification	Page No.	23/27
Document No.		Revision	1.0

8.2 Back View Outline Dimension

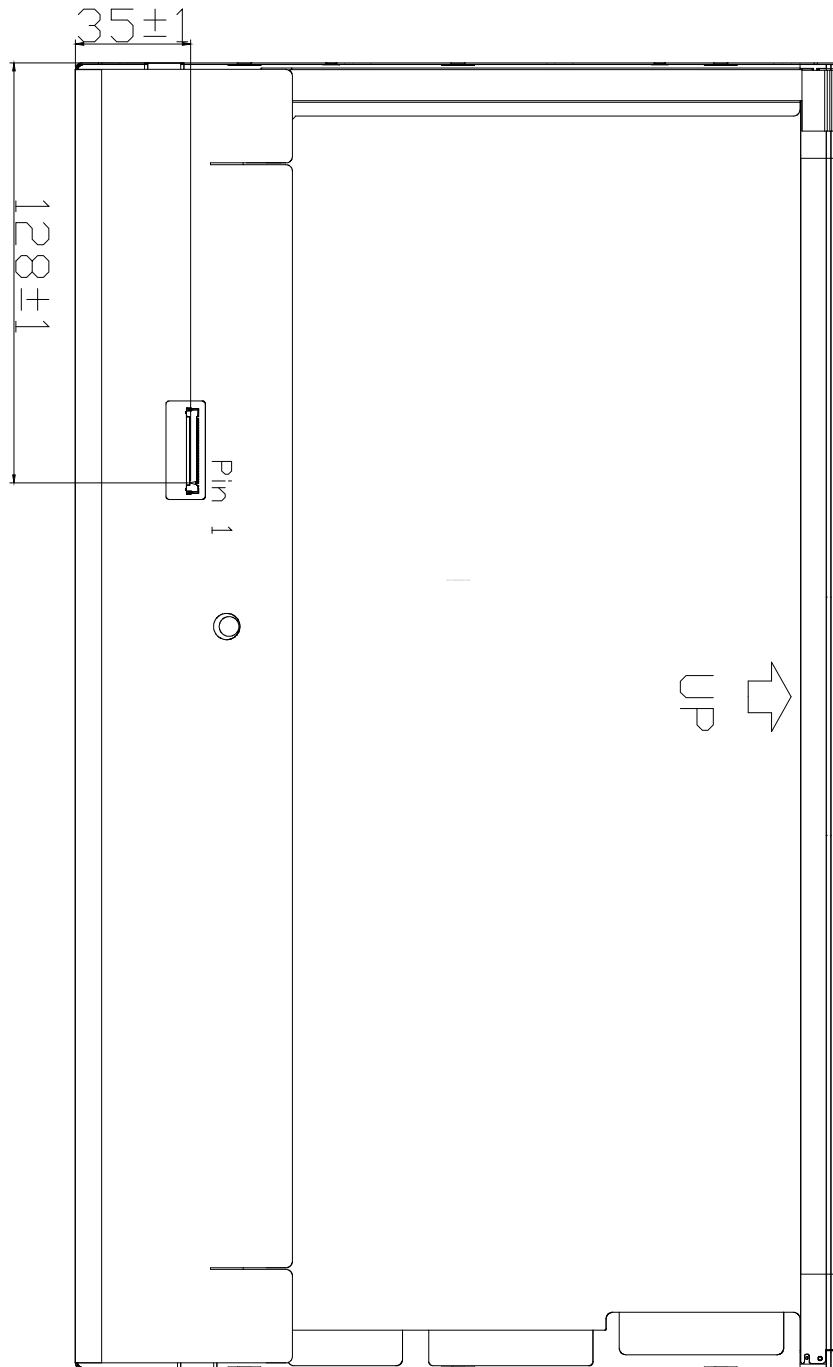

Document Title	HSD173PUW1-A Formal Specification	Page No.	24/27
Document No.		Revision	1.0

9.0 LOT MARK

9.1 Lot Mark

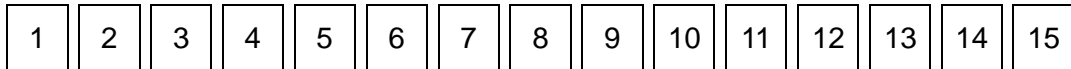

Code 1,2,3,4,5,6: HannStar internal flow control code.

Code 7: production location.

Code 8: production year.

Code 9: production month.

Code 10,11,12,13,14,15: serial number.

Note (1) Production Year

Year	2001	2002	2003	2004	2005	2006	2007	2008	2009	2010
Mark	1	2	3	4	5	6	7	8	9	0

Note (2) Production Month

Month	Jan.	Feb.	Mar.	Apr.	May.	Jun.	Jul.	Aug.	Sep.	Oct	Nov.	Dec.
Mark	1	2	3	4	5	6	7	8	9	A	B	C

9.2 Location of Lot Mark

- (1) The label is attached to the backside of the LCD module.
- (2) This is subject to change without prior notice.

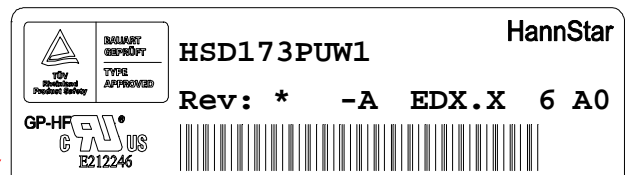
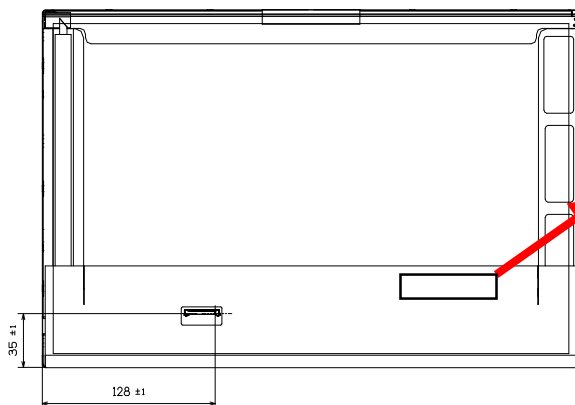

Document Title	HSD173PUW1-A Formal Specification	Page No.	25/27
Document No.		Revision	1.0

10.0 PACKAGE SPECIFICATION

10.1 Packing form

LCM Model	LCM Qty. in the box	Inner Box Size (mm)	Notice
HSD173PUW1-A	35 pcs/box	556 x 318 x 500 ^H	

10.2 Packing assembly drawings

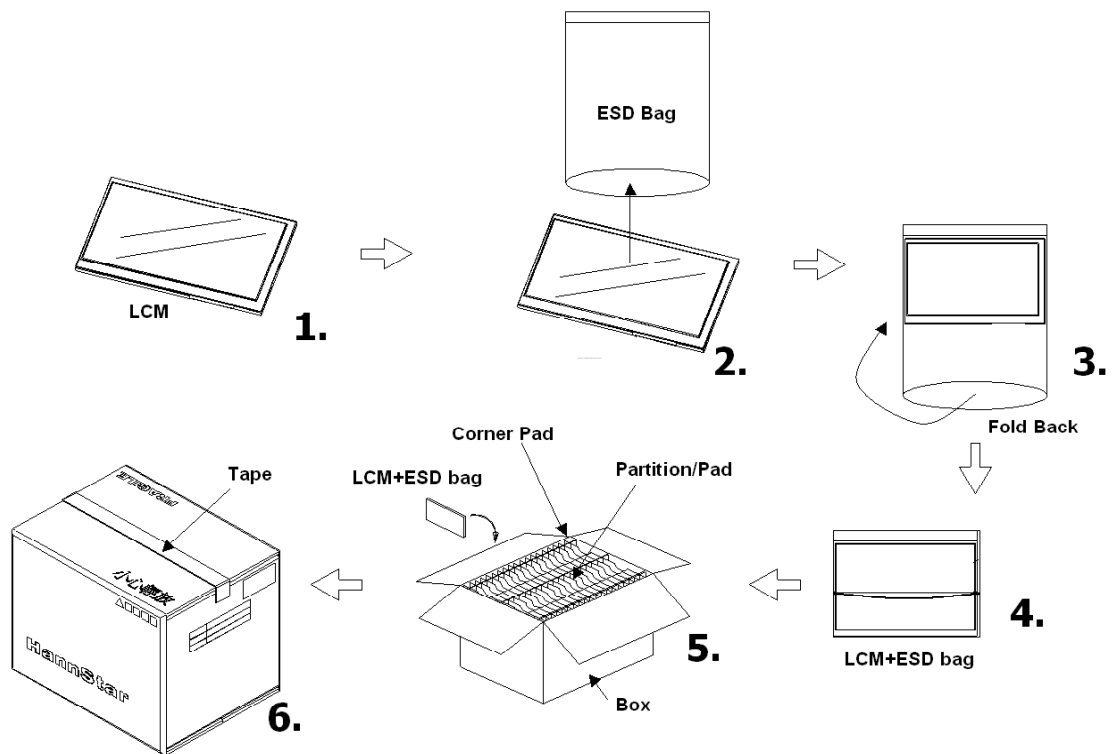

HSD173PHW1-A	Material	Notice
Box	Corrugated Paper Board	(AB Flute)
Partition/Pad	Corrugated Paper Board	(B Flute)
Corner Pad	Corrugated Paper Board	(AB Flute)
ESD bag	PE	--

Document Title	HSD173PUW1-A Formal Specification	Page No.	26/27
Document No.		Revision	1.0

11.0 GENERAL PRECAUTION

11.1 Use Restriction

This product is not authorized for use in life supporting systems, aircraft navigation control systems, military systems and any other application where performance failure could be life-threatening or otherwise catastrophic.

11.2 Disassembling or Modification

Do not disassemble or modify the module. It may damage sensitive parts inside LCD module, and may cause scratches or dust on the display. HannStar does not warrant the module, if customers disassemble or modify the module.

11.3 Breakage of LCD Panel

11.3.1. If LCD panel is broken and liquid crystal spills out, do not ingest or inhale liquid crystal, and do not contact liquid crystal with skin.

11.3.2. If liquid crystal contacts mouth or eyes, rinse out with water immediately.

11.3.3. If liquid crystal contacts skin or cloths, wash it off immediately with alcohol and rinse thoroughly with water.

11.3.4. Handle carefully with chips of glass that may cause injury, when the glass is broken.

11.4 Electric Shock

11.4.1. Disconnect power supply before handling LCD module.

11.4.2. Do not pull or fold the LED cable.

11.4.3. Do not touch the parts inside LCD modules and the fluorescent LED's connector or cables in order to prevent electric shock.

11.5 Absolute Maximum Ratings and Power Protection Circuit

11.5.1. Do not exceed the absolute maximum rating values, such as the supply voltage variation, input voltage variation, variation in parts' parameters, environmental temperature, etc., otherwise LCD module may be damaged.

11.5.2. Please do not leave LCD module in the environment of high humidity and high temperature for a long time.

11.5.3. It's recommended to employ protection circuit for power supply.

11.6 Operation

11.6.1 Do not touch, push or rub the polarizer with anything harder than HB pencil lead.

11.6.2 Use fingerstalls of soft gloves in order to keep clean display quality, when persons handle the LCD module for incoming inspection or assembly.

11.6.3 When the surface is dusty, please wipe gently with absorbent cotton or other soft material.



Document Title	HSD173PUW1-A Formal Specification	Page No.	27/27
Document No.		Revision	1.0

11.6.4 Wipe off saliva or water drops as soon as possible. If saliva or water drops contact with polarizer for a long time, they may causes deformation or color fading.

11.6.5 When cleaning the adhesives, please use absorbent cotton wetted with a little petroleum benzine or other adequate solvent.

11.7 Mechanism

Please mount LCD module by using mounting holes arranged in four corners tightly.

11.8 Static Electricity

11.8.1 Protection film must remove very slowly from the surface of LCD module to prevent from electrostatic occurrence.

11.8.2 Because LCD module use CMOS-IC on circuit board and TFT-LCD panel, it is very weak to electrostatic discharge. Please be careful with electrostatic discharge. Persons who handle the module should be grounded through adequate methods.

11.9 Strong Light Exposure

The module shall not be exposed under strong light such as direct sunlight. Otherwise, display characteristics may be changed.

11.10 Disposal

When disposing LCD module, obey the local environmental regulations.