



HannStar Display Corp.

|                |   |          |        |
|----------------|---|----------|--------|
| Document Title | <b>HSD190ME12-A02</b> Product Information | Page No. | 1 / 27 |
| Document No.   |   | Revision | 0.1    |

To :Sebon

Date : Dec. 23, 2004

## Product Information

Model : **HSD190ME12**  
**- A02**

- Note:
1. Please contact HannStar Display Corp. before designing your product based on this module specification.
  2. The information contained herein is presented merely to indicate the characteristics and performance of our products. No responsibility is assumed by HannStar for any intellectual property claims or other problems that may result from application based on the module described herein.



HannStar Display Corp.

|                |   |          |        |
|----------------|---|----------|--------|
| Document Title | <b>HSD190ME12-A02</b> Product Information | Page No. | 2 / 27 |
| Document No.   |   | Revision | 0.1    |

### Record of Revisions

| Rev. | Updated No. | Date        | Description of change                                    |
|------|-------------|-------------|--|
| 0.1  | --          | Dec.23,2004 | Product Information for HSD190ME12-A02 was first issued. |

The information contained in this document is the exclusive property of HannStar Display Corporation. It shall not be disclosed, distributed or reproduced in whole or in part without written permission of HannStar Display Corporation.



HannStar Display Corp.

|                |   |          |        |
|----------------|---|----------|--------|
| Document Title | <b>HSD190ME12-A02</b> Product Information | Page No. | 3 / 27 |
| Document No.   |   | Revision | 0.1    |

## Contents

|      |                                     |      |
|------|-------------------------------------|------|
| 1.0  | General descriptions .....          | p.4  |
| 2.0  | Absolute maximum ratings .....      | p.5  |
| 3.0  | Optical characteristics .....       | p.7  |
| 4.0  | Block diagram .....                 | p.12 |
| 5.0  | I/O Connection Pin assignment ..... | p.15 |
| 6.0  | Electrical Characteristics .....    | p.16 |
| 7.0  | Input Timing Spec.....              | p.21 |
| 8.0  | Outline dimension .....             | p.22 |
| 9.0  | Lot Mark .....                      | p.24 |
| 10.0 | Package Specification .....         | P.26 |
| 11.0 | General precaution .....            | p.27 |



|                |   |          |        |
|----------------|---|----------|--------|
| Document Title | <b>HSD190ME12-A02</b> Product Information | Page No. | 4 / 27 |
| Document No.   |   | Revision | 0.1    |

## 1.0 GENERAL DESCRIPTIONS

### 1.1 Introduction

HannStar Display model **HSD190ME12-A02** is a color active matrix thin film transistor (TFT) liquid crystal display (LCD) that uses amorphous silicon TFT as a switching device. This model is composed of a TFT LCD panel, the voltage reference, common voltage, DC-DC converter, column, and row driver circuit. This TFT LCD has a 19-inch diagonally measured active display area with SXGA resolution (1024 vertical by 1280 horizontal pixel array).

### 1.2 Features

- 19" SXGA TFT LCD panel
- 4 CCFLs Backlight system
- Supported SXGA (V:1024 lines, H:1280 pixels) resolution
- Supported to 75Hz refresh rate
- With LCD Timing Controller

### 1.3 General information

| Item                            | Specification                   |    | Unit   |
|---------------------------------|---------------------------------|----|--------|
| Outline dimension               | 404.2(H) X 330(V) X 19.0 (typ.) |    | mm     |
| Display area                    | 376.32(W) x 301.056(H)          |    | mm     |
| Number of Pixel                 | 1280(H) x 1024(V)               |    | Pixels |
| Pixel pitch                     | 0.294(H) x 0.294(V)             |    | mm     |
| Pixel arrangement               | RGB Vertical stripe             |    |        |
| Display color                   | 16.2M (6-bits+FRC)              |    |        |
| Display mode                    | Normally white                  |    |        |
| Surface treatment               | Antiglare, Hard-Coating(3H)     |    |        |
| Weight                          | 2350(typ.)                      |    | G      |
| Back-light                      | 4-CCFLs, Top & bottom edge side |    |        |
| Input signal                    | 2 -CH LVDS                      |    |        |
| Power consumption<br>(with B/L) | System                          | 3  | W      |
|                                 | B/L                             | 22 |        |
| Optimum viewing direction       | 6 o'clock                       |    |        |

### 1.4 Applications

- Desktop monitors
- Display terminals for AV applications
- Monitors for industrial applications



|                |   |          |        |
|----------------|---|----------|--------|
| Document Title | <b>HSD190ME12-A02</b> Product Information | Page No. | 5 / 27 |
| Document No.   |   | Revision | 0.1    |

**1.5 Mechanical Information**

| Item                          |               | Min. | Typ.  | Max. | Unit   |
|-------------------------------|---------------|------|-------|------|--------|
| Module Size                   | Horizontal(H) | --   | 404.2 | --   | mm     |
|                               | Vertical(V)   | --   | 330   | --   | mm     |
|                               | Depth(D)      | --   | 19    | --   | mm     |
| Weight (without inverter)     |               | 2230 | 2350  | 1470 | g      |
| Torque of customer screw hole |               |      |       | 3.0  | Kgf*Cm |

**2.0 ABSOLUTE MAXIMUM RATINGS**

**2.1 Absolute Rating of Environment**

| Item                        | Symbol            | Min. | Max. | Unit | Note |
|-----------------------------|-------------------|------|------|------|------|
| Storage temperature         | T <sub>STG</sub>  | -20  | 60   | °C   |      |
| Operating temperature       | T <sub>OPR</sub>  | 0    | 50   | °C   | (1)  |
| Vibration(non-operating)    | V <sub>NOP</sub>  | --   | 1.5  | G    | (2)  |
| Shock(non-operating)        | S <sub>NOP</sub>  | --   | 70   | G    | (3)  |
| Storage humidity            | H <sub>STG</sub>  | 10   | 90   | %RH  | (3)  |
| Operating humidity          | H <sub>OP</sub>   | 10   | 80   | %RH  | (4)  |
| Low pressure(operating)     | P <sub>LOP</sub>  | 697  | --   | HPa  | (5)  |
| Low pressure(non-operating) | P <sub>LNOP</sub> | 116  | --   | HPa  | (6)  |

Note (1)Storage /Operating temperature

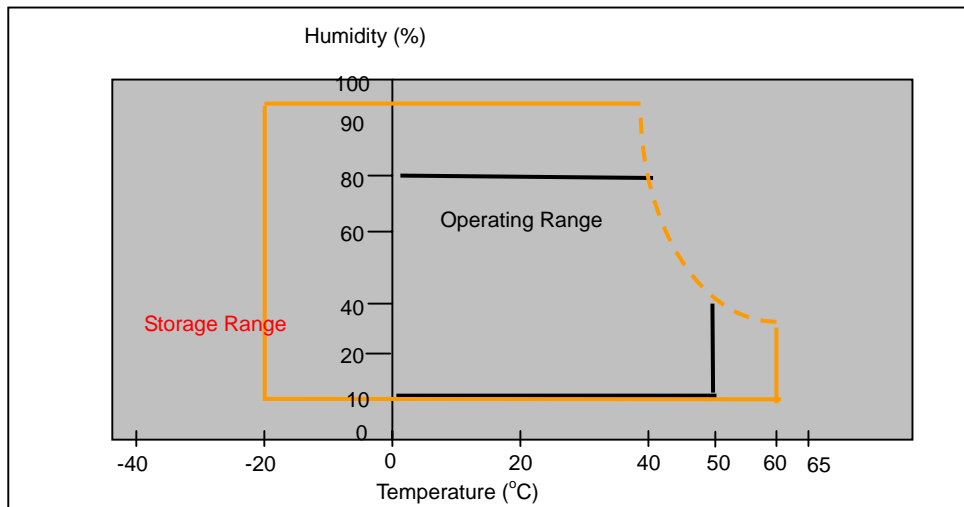



|                |   |          |        |
|----------------|---|----------|--------|
| Document Title | <b>HSD190ME12-A02</b> Product Information | Page No. | 6 / 27 |
| Document No.   |   | Revision | 0.1    |

- (2) **5-500** Hz sine wave, X,Y,Z each directions, 30 min/cycle.
- (3) 11ms,  $\pm X$ ,  $\pm Y$ ,  $\pm Z$  direction, one time each. For this shock test,  
It is necessary to fill the silicon rubber between the shock jig as buffer.
- (4) Max wet bulb temp. =39°C
- (5) **2** hrs. (10000 feet)
- (6) 24hrs. (50000 feet)

## 2.2 Electrical Absolute Rating:

### 2.2.1 TFT LCD Module:

| Item                 | Symbol          | Min. | Max. | Unit. | Note   |
|----------------------|-----------------|------|------|-------|--------|
| Power supply Voltage | V <sub>DD</sub> | -0.3 | 5.5  | V(DC) | (1)(2) |

### 2.2.2 Back Light Unit:

| Item           | Symbol         | Min. | Max. | Unit   | Note   |
|----------------|----------------|------|------|--------|--------|
| Lamp voltage   | V <sub>L</sub> | 630  | 770  | V(rms) | (1)(2) |
| Lamp current   | I <sub>L</sub> | 3.5  | 9.0  | mA     | (1)(2) |
| Lamp frequency | f <sub>L</sub> | 40   | 80   | KHz    | (1)(2) |

Note: (1) Permanent damage may occur to the LCD module if beyond this specification.

Functional operation should be restricted to the conditions described under Normal Operating Conditions.

- (2) To exceed 6.5mA, life time accelerate drop down and if to exceed 9.0 mA has safety problem. If current is lower than 3.0 mA, CCFL would be unstable or damaged.
- (3) Within Ta=25±2°C.



|                |   |          |        |
|----------------|---|----------|--------|
| Document Title | <b>HSD190ME12-A02</b> Product Information | Page No. | 7 / 27 |
| Document No.   |   | Revision | 0.1    |

### 3.0 OPTICAL CHARACTERISTICS

#### 3.1 Optical specification

| Item                                  | Symbol    | Condition  | Min.   | Typ.  | Max. | Unit              | Note                    |        |
|---------------------------------------|-----------|--|--------|-------|------|-------------------|-------------------------|--------|
| Contrast                              | CR        | $=0^\circ$<br>$\phi=0^\circ$<br>Normal viewing angle | --     | 600   | --   |                   | (1)(2)                  |        |
| Response time                         | Rising    |  | TR +TF | --    | 12   | --                | msec                    | (1)(3) |
|                                       | Falling   |  |        |       |      |                   |                         |        |
| White luminance<br>(center of screen) | $Y_L$     |  | --     | 250   |      | cd/m <sup>2</sup> | (1)(4)(5)<br>(IL=6.5mA) |        |
| Color chromaticity<br>(CIE1931)       | Red       | Rx   | --     | 0.647 | --   |                   | (1)(4)                  |        |
|                                       |           | Ry   | --     | 0.327 | --   |                   |                         |        |
|                                       | Green     | Gx   | --     | 0.292 | --   |                   |                         |        |
|                                       |           | Gy   | --     | 0.614 | --   |                   |                         |        |
|                                       | Blue      | Bx   | --     | 0.142 | --   |                   |                         |        |
|                                       |           | By   | --     | 0.079 | --   |                   |                         |        |
|                                       | White     | Wx   | --     | 0.310 | --   |                   |                         |        |
| Wy                                    |           | --   | 0.330  | --    |      |                   |                         |        |
| Viewing angle                         | Hor.      | L  | --     | 70    | --   |                   |                         |        |
|                                       |           | R  | --     | 70    | --   |                   |                         |        |
|                                       | Ver.      | H  | --     | 65    | --   |                   |                         |        |
|                                       |           | L  | --     | 65    | --   |                   |                         |        |
| Brightness uniformity                 | $B_{UNI}$ | $=0^\circ$   | 75     | 80    | --   | %                 | (6)                     |        |
| Crosstalk                             | CT(n)     | $\phi=0^\circ$                                       | --     | --    | 1.3  | %                 | (7)                     |        |

#### 3.2 Measuring Condition

- Measuring surrounding : dark room
- Lamp current  $I_{BL}$  : (6.5)±0.1mA, lamp freq.  $F_L=48$  KHz, Inverter : EMAX19402E(22pf)
- $V_{DD1}=5.0V$ ,  $f_V=60Hz$ ,  $f_{DCLK}=54MHz$
- Surrounding temperature : 25±2°C
- 30min. Warm-up time.

#### 3.3 Measuring Equipment

- LCD-7000 of Otsuka Electric Corp., which utilized MCPD-7000 for Chromaticity and BM-5A for other optical characteristics.
- Measuring spot size : 10~12mm

|                |   |          |        |
|----------------|---|----------|--------|
| Document Title | <b>HSD190ME12-A02</b> Product Information | Page No. | 8 / 27 |
| Document No.   |   | Revision | 0.1    |

Note (1) Definition of Viewing Angle:

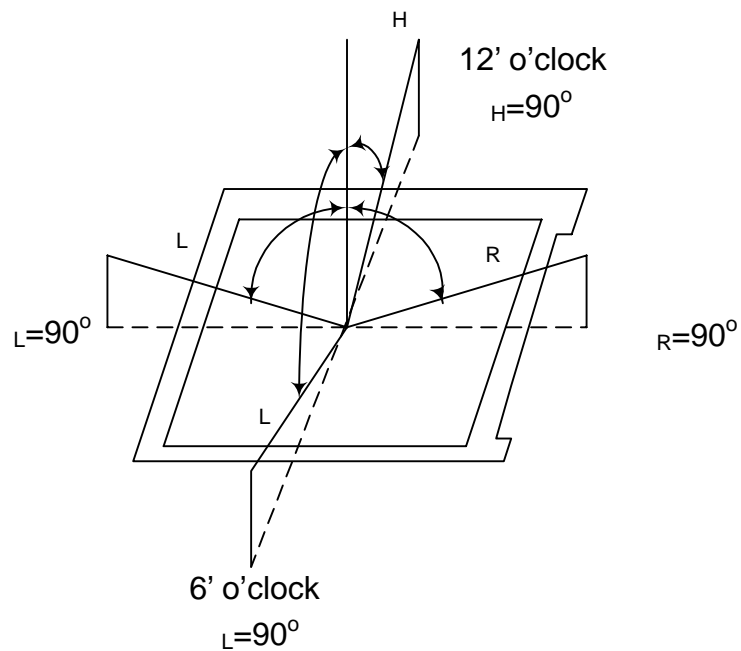

Note (2) Definition of Contrast Ratio(CR) :  
measured at the center point of panel

$$CR = \frac{\text{Luminance with all pixels white (L255)}}{\text{Luminance with all pixels black (L0)}}$$





|                |   |          |        |
|----------------|---|----------|--------|
| Document Title | <b>HSD190ME12-A02</b> Product Information | Page No. | 9 / 27 |
| Document No.   |   | Revision | 0.1    |

Note (3) Definition of Response Time: Sum of  $T_R$  and  $T_F$

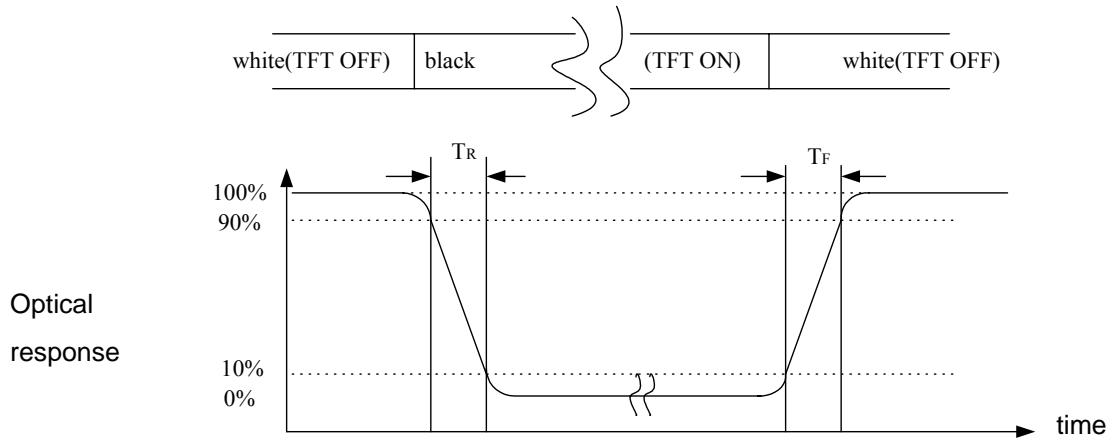

Note (4) Optical characteristic measurement setup

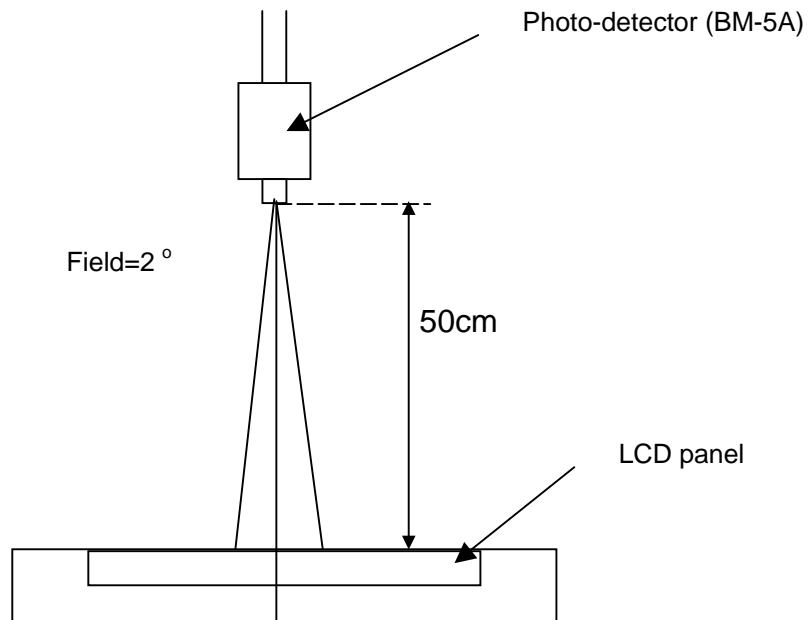



|                |   |          |         |
|----------------|---|----------|---------|
| Document Title | <b>HSD190ME12-A02</b> Product Information | Page No. | 10 / 27 |
| Document No.   |   | Revision | 0.1     |

Note (5) Definition of Center Luminance of White

Center Luminance= Y1

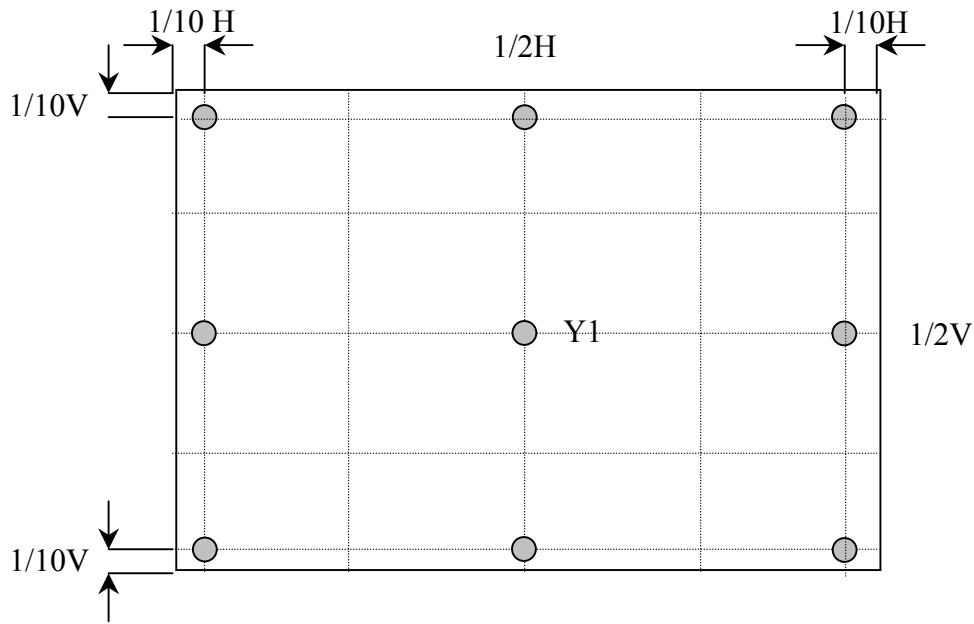

Note (6) Definition of brightness uniformity

$$\text{Luminance uniformity} = \frac{(\text{Min Luminance of 9 points})}{(\text{Max Luminance of 9 points})} \times 100\%$$



|                |  |          |        |
|----------------|--|----------|--------|
| Document Title | HSD190ME12-A Preliminary specification | Page No. | 11 /28 |
| Document No.   |  | Revision | 0.1    |

Note (7) Definition of crosstalk CT (1) ~ CT (4)

$$CT(n) = \frac{|L(n) - LB(n)|}{L(n)} \times 100\% , n = 1 \sim 4$$

Where L(n) = Luminance of point "n" at pattern A (cd/m<sup>2</sup>) , n=1 ~ 4

LB(n) = Luminance of point "n" at pattern B (cd/m<sup>2</sup>) , n=1 ~ 4

The location measured will be exactly the same in both patterns.

L0: Luminance with all pixels black

L255: Luminance with all pixels white

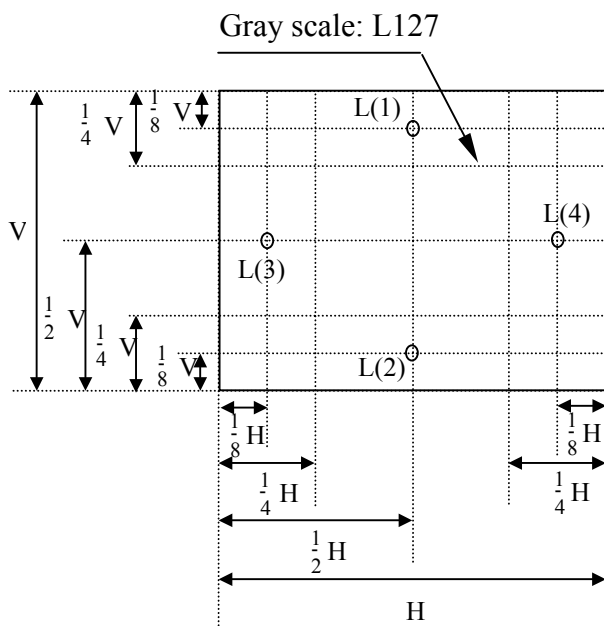

Pattern A

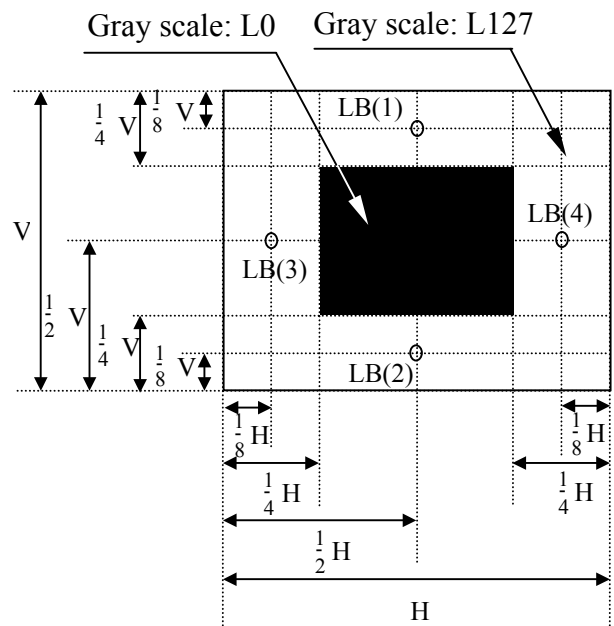

Pattern B



|                |  |          |        |
|----------------|--|----------|--------|
| Document Title | HSD190ME12-A Preliminary specification | Page No. | 12 /28 |
| Document No.   |  | Revision | 0.1    |

#### 4.0 BLOCK DIAGRAM

##### 4.1 LCD Module Block Diagram:

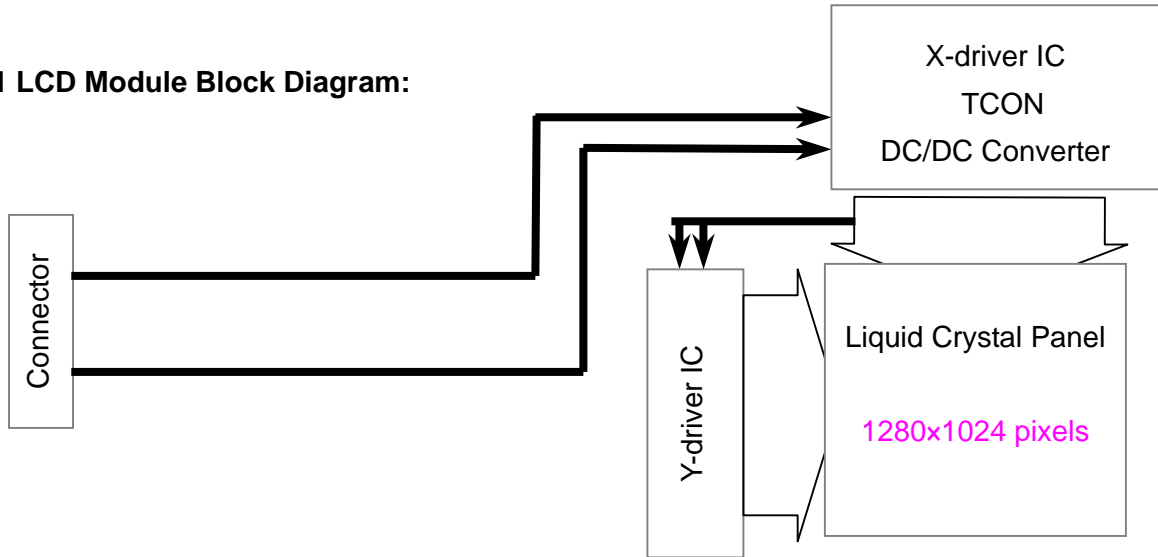



HannStar Display Corp.

|                |  |          |        |
|----------------|--|----------|--------|
| Document Title | HSD190ME12-A Preliminary specification | Page No. | 13 /28 |
| Document No.   |  | Revision | 0.1    |

### 4.2 Back Light Unit

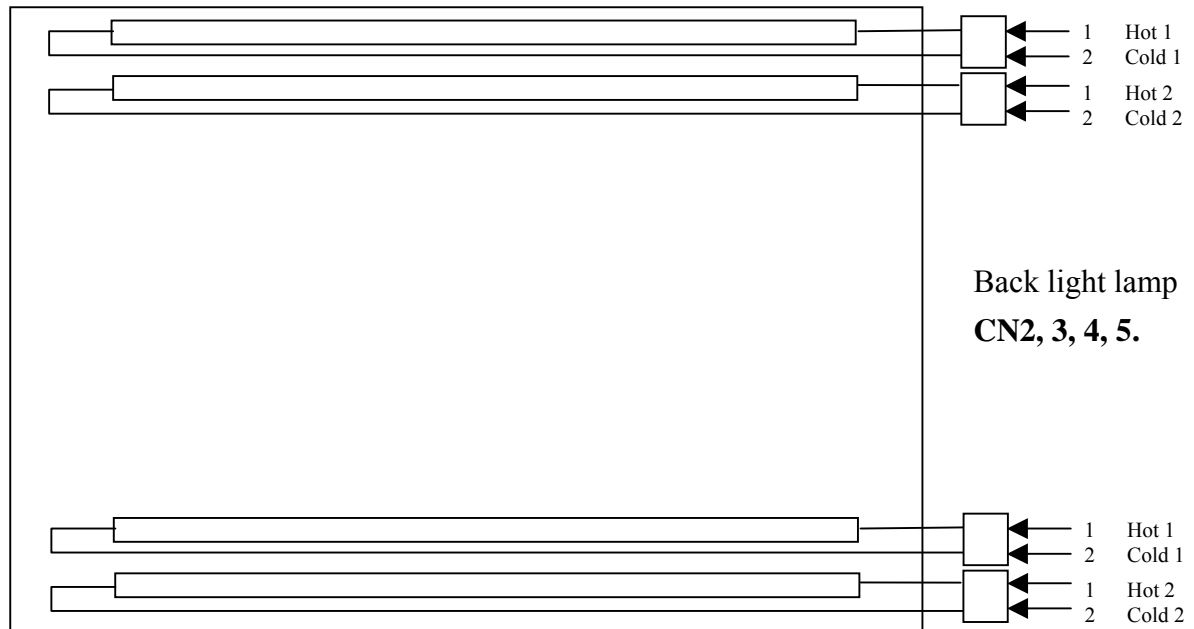

### 4.3 Pixel Format

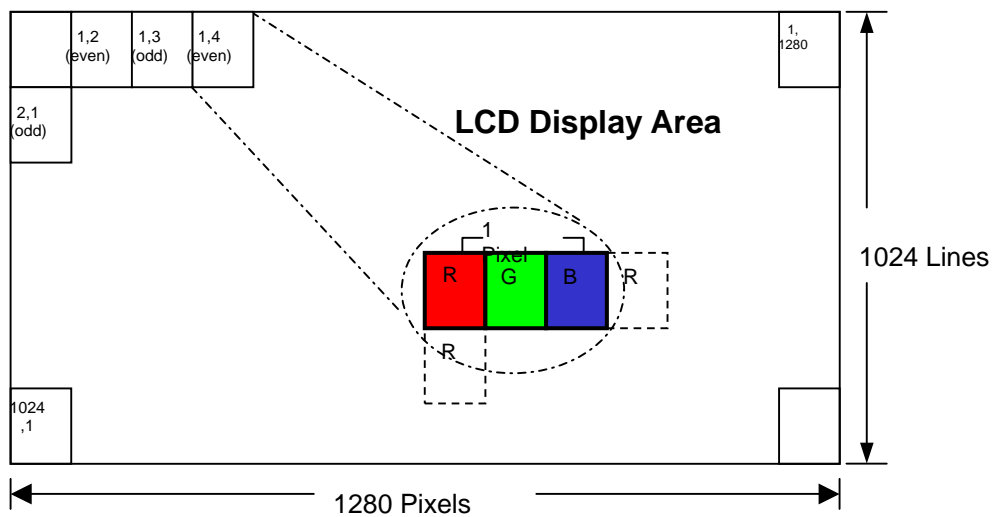



|                |  |          |        |
|----------------|--|----------|--------|
| Document Title | HSD190ME12-A Preliminary specification | Page No. | 14 /28 |
| Document No.   |  | Revision | 0.1    |

#### 4.4 Relationship Between Displayed Color and Input

| Display                     | MSB        |    |    |    | LSB |    |    |    | MSB |    |    |    | LSB |    |    |    | Gray scale Level |    |    |    |    |    |    |    |            |           |
|-----------------------------|------------|----|----|----|-----|----|----|----|-----|----|----|----|-----|----|----|----|------------------|----|----|----|----|----|----|----|------------|-----------|
|                             | R7         | R6 | R5 | R4 | R3  | R2 | R1 | R0 | G7  | G6 | G5 | G4 | G3  | G2 | G1 | G0 |                  | B7 | B6 | B5 | B4 | B3 | B2 | B1 | B0         |           |
| Basic color                 | Black      | L  | L  | L  | L   | L  | L  | L  | L   | L  | L  | L  | L   | L  | L  | L  | L                | L  | L  | L  | L  | L  | L  | L  | L          | -         |
|                             | Blue       | L  | L  | L  | L   | L  | L  | L  | L   | L  | L  | L  | L   | L  | L  | L  | L                | H  | H  | H  | H  | H  | H  | H  | H          | -         |
|                             | Green      | L  | L  | L  | L   | L  | L  | L  | L   | H  | H  | H  | H   | H  | H  | H  | H                | L  | L  | L  | L  | L  | L  | L  | L          | -         |
|                             | Light Blue | L  | L  | L  | L   | L  | L  | L  | L   | H  | H  | H  | H   | H  | H  | H  | H                | H  | H  | H  | H  | H  | H  | H  | H          | -         |
|                             | Red        | H  | H  | H  | H   | H  | H  | H  | H   | L  | L  | L  | L   | L  | L  | L  | L                | L  | L  | L  | L  | L  | L  | L  | L          | -         |
|                             | Purple     | H  | H  | H  | H   | H  | H  | H  | H   | L  | L  | L  | L   | L  | L  | L  | L                | H  | H  | H  | H  | H  | H  | H  | H          | -         |
|                             | Yellow     | H  | H  | H  | H   | H  | H  | H  | H   | H  | H  | H  | H   | H  | H  | H  | H                | L  | L  | L  | L  | L  | L  | L  | L          | -         |
|                             | White      | H  | H  | H  | H   | H  | H  | H  | H   | H  | H  | H  | H   | H  | H  | H  | H                | H  | H  | H  | H  | H  | H  | H  | H          | -         |
| Gray scale of Red           | Black      | L  | L  | L  | L   | L  | L  | L  | L   | L  | L  | L  | L   | L  | L  | L  | L                | L  | L  | L  | L  | L  | L  | L  | L          | L0        |
|                             | Dark       | L  | L  | L  | L   | L  | L  | L  | H   | L  | L  | L  | L   | L  | L  | L  | L                | L  | L  | L  | L  | L  | L  | L  | L          | L1        |
|                             |            | L  | L  | L  | L   | L  | L  | H  | L   | L  | L  | L  | L   | L  | L  | L  | L                | L  | L  | L  | L  | L  | L  | L  | L          | L2        |
|                             |            | :  | :  | :  | :   | :  | :  | :  | :   | :  | :  | :  | :   | :  | :  | :  | :                | :  | :  | :  | :  | :  | :  | :  | :          | L3 L251   |
|                             | Light      | H  | H  | H  | H   | H  | L  | H  | H   | L  | L  | L  | L   | L  | L  | L  | L                | L  | L  | L  | L  | L  | L  | L  | L          | L255      |
|                             |            | H  | H  | H  | H   | H  | H  | L  | H   | L  | L  | L  | L   | L  | L  | L  | L                | L  | L  | L  | L  | L  | L  | L  | L          | L255      |
|                             |            | H  | H  | H  | H   | H  | H  | H  | L   | L  | L  | L  | L   | L  | L  | L  | L                | L  | L  | L  | L  | L  | L  | L  | L          | L255      |
|                             | Red        | H  | H  | H  | H   | H  | H  | H  | H   | L  | L  | L  | L   | L  | L  | L  | L                | L  | L  | L  | L  | L  | L  | L  | L          | Red L255  |
| Gray scale of Green         | Black      | L  | L  | L  | L   | L  | L  | L  | L   | L  | L  | L  | L   | L  | L  | L  | L                | L  | L  | L  | L  | L  | L  | L  | L          | L0        |
|                             | Dark       | L  | L  | L  | L   | L  | L  | L  | L   | L  | L  | L  | L   | L  | L  | L  | H                | L  | L  | L  | L  | L  | L  | L  | L          | L1        |
|                             |            | L  | L  | L  | L   | L  | L  | L  | L   | L  | L  | L  | L   | L  | L  | H  | L                | L  | L  | L  | L  | L  | L  | L  | L          | L2        |
|                             |            | :  | :  | :  | :   | :  | :  | :  | :   | :  | :  | :  | :   | :  | :  | :  | :                | :  | :  | :  | :  | :  | :  | :  | :          | L3 L251   |
|                             | Light      | L  | L  | L  | L   | L  | L  | L  | L   | H  | H  | H  | H   | L  | H  | H  | L                | L  | L  | L  | L  | L  | L  | L  | L255       |           |
|                             |            | L  | L  | L  | L   | L  | L  | L  | L   | H  | H  | H  | H   | H  | L  | H  | L                | L  | L  | L  | L  | L  | L  | L  | L255       |           |
|                             |            | L  | L  | L  | L   | L  | L  | L  | L   | H  | H  | H  | H   | H  | H  | L  | L                | L  | L  | L  | L  | L  | L  | L  | L255       |           |
|                             | Green      | L  | L  | L  | L   | L  | L  | L  | L   | H  | H  | H  | H   | H  | H  | H  | L                | L  | L  | L  | L  | L  | L  | L  | Green L255 |           |
| Gray scale of Blue          | Black      | L  | L  | L  | L   | L  | L  | L  | L   | L  | L  | L  | L   | L  | L  | L  | L                | L  | L  | L  | L  | L  | L  | L  | L          | L0        |
|                             | Dark       | L  | L  | L  | L   | L  | L  | L  | L   | L  | L  | L  | L   | L  | L  | L  | L                | L  | L  | L  | L  | L  | L  | L  | H          | L1        |
|                             |            | L  | L  | L  | L   | L  | L  | L  | L   | L  | L  | L  | L   | L  | L  | L  | L                | L  | L  | L  | L  | L  | L  | H  | L          | L2        |
|                             |            | :  | :  | :  | :   | :  | :  | :  | :   | :  | :  | :  | :   | :  | :  | :  | :                | :  | :  | :  | :  | :  | :  | :  | :          | L3 L251   |
|                             | Light      | L  | L  | L  | L   | L  | L  | L  | L   | L  | L  | L  | L   | L  | L  | L  | L                | H  | H  | H  | H  | L  | H  | H  | H          | L255      |
|                             |            | L  | L  | L  | L   | L  | L  | L  | L   | L  | L  | L  | L   | L  | L  | L  | L                | H  | H  | H  | H  | H  | L  | H  | H          | L255      |
|                             |            | L  | L  | L  | L   | L  | L  | L  | L   | L  | L  | L  | L   | L  | L  | L  | L                | H  | H  | H  | H  | H  | H  | L  | H          | L255      |
|                             | Blue       | L  | L  | L  | L   | L  | L  | L  | L   | L  | L  | L  | L   | L  | L  | L  | L                | H  | H  | H  | H  | H  | H  | H  | H          | Blue L255 |
| Gray scale of White & Black | Black      | L  | L  | L  | L   | L  | L  | L  | L   | L  | L  | L  | L   | L  | L  | L  | L                | L  | L  | L  | L  | L  | L  | L  | L          | L0        |
|                             | Dark       | L  | L  | L  | L   | L  | L  | L  | H   | L  | L  | L  | L   | L  | L  | H  | L                | L  | L  | L  | L  | L  | L  | H  | L1         |           |
|                             |            | L  | L  | L  | L   | L  | L  | H  | L   | L  | L  | L  | L   | L  | H  | L  | L                | L  | L  | L  | L  | L  | H  | L  | L2         |           |
|                             |            | :  | :  | :  | :   | :  | :  | :  | :   | :  | :  | :  | :   | :  | :  | :  | :                | :  | :  | :  | :  | :  | :  | :  | L3 L251    |           |
|                             | Light      | H  | H  | H  | H   | H  | L  | H  | H   | H  | H  | H  | H   | L  | H  | H  | H                | H  | H  | H  | L  | H  | H  | H  | L255       |           |
|                             |            | H  | H  | H  | H   | H  | H  | L  | H   | H  | H  | H  | H   | H  | L  | H  | H                | H  | H  | H  | H  | L  | H  | H  | L255       |           |
|                             |            | H  | H  | H  | H   | H  | H  | H  | L   | H  | H  | H  | H   | H  | H  | L  | H                | H  | H  | H  | H  | H  | L  | H  | L255       |           |
|                             | White      | H  | H  | H  | H   | H  | H  | H  | H   | H  | H  | H  | H   | H  | H  | H  | H                | H  | H  | H  | H  | H  | H  | H  | White L255 |           |



|                |  |          |        |
|----------------|--|----------|--------|
| Document Title | HSD190ME12-A Preliminary specification | Page No. | 15 /28 |
| Document No.   |  | Revision | 0.1    |

## 5.0 I/O CONNECTION PIN ASSIGNMENT

### 5.1 Interface Connector (30-pins ) (JAE: FI-X30SSL-HF)

#### CN1 : Data Signal and Power Supply (FI-X30S-HF /JAE)

| Pin No. | Symbol          | Description                |
|---------|-----------------|----------------------------|
| 1       | RXO0-           | Receiver Signal (-)        |
| 2       | RXO0+           | Receiver Signal (+)        |
| 3       | RXO1-           | Receiver Signal (-)        |
| 4       | RXO1+           | Receiver Signal (+)        |
| 5       | RXO2-           | Receiver Signal (-)        |
| 6       | RXO2+           | Receiver Signal (+)        |
| 7       | GND             | Ground                     |
| 8       | RXOC-           | Clock Signal (-)           |
| 9       | RXOC+           | Clock Signal (+)           |
| 10      | RXO3-           | Receiver Signal (-)        |
| 11      | RXO3+           | Receiver Signal (+)        |
| 12      | RXE0-           | Receiver Signal (-)        |
| 13      | RXEO+           | Receiver Signal (+)        |
| 14      | GND             | Receiver Signal (+)        |
| 15      | RXE1-           | Receiver Signal (-)        |
| 16      | RXE1+           | Receiver Signal (+)        |
| 17      | GND             | Ground                     |
| 18      | RXE2-           | Receiver Signal (-)        |
| 19      | RXE2+           | Receiver Signal (+)        |
| 20      | RXEC-           | Clock Signal (-)           |
| 21      | RXEC+           | Clock Signal (+)           |
| 22      | RXE3-           | Receiver Signal (-)        |
| 23      | RXE3+           | Receiver Signal (+)        |
| 24      | GND             | Ground                     |
| 25      | GND             | Ground                     |
| 26      | NC              | NC                         |
| 27      | VSS             | Ground                     |
| 28      | V <sub>DD</sub> | Power Supply, 5V (Typical) |
| 29      | V <sub>DD</sub> | Power Supply, 5V (Typical) |
| 30      | V <sub>DD</sub> | Power Supply, 5V (Typical) |

Note 1) Please connects NC pin & Test pin to nothing. Don't connect it to ground nor to other signal input.

Note 2) Please connects GND pin to ground. Don't use it as no-connect nor connect with high impedanc

### 5.2 Back Light Unit (CCFL) Connectors:

#### CN2, 3, 4, 5: CCFL Power Source (BHR-02VS-1)

| Pin No. | Symbol | Color | Function                         |
|---------|--------|-------|----------------------------------|
| 1       | Hot1   | Pink  | CCFL power supply (High voltage) |
| 2       | Cold1  | White | Ground                           |

|                |  |          |        |
|----------------|--|----------|--------|
| Document Title | HSD190ME12-A Preliminary specification | Page No. | 16 /28 |
| Document No.   |  | Revision | 0.1    |

## 6.0 ELECTRICAL CHARACTERISTICS

### 6.1 TFT LCD Module:

| Item                    | Symbol     | Min.      | Typ.  | Max. | Unit | Note   |        |
|-------------------------|------------|-----------|-------|------|------|--------|--------|
| Voltage of power supply | $V_{DD}$   | --        | 5.0   | --   | V    |        |        |
| Current of power supply | V-Color    | $I_{DD1}$ | --    | 430  | --   | mA     | (1)(3) |
|                         | Mosaic     | $I_{DD2}$ | --    | 480  | -    | mA     | (1)(3) |
| Vsync frequency         | $f_V$      | --        | 60    | --   | Hz   | (2)(3) |        |
| Hsync frequency         | $f_H$      | -         | 63.19 | --   | KHz  |        |        |
| Frequency               | $f_{DCLK}$ | --        | 54    | --   | MHz  |        |        |
| Input rush current      | $I_{RUSH}$ | ---       | ---   | 3.0  | A    | (3)(4) |        |

Note (1)

1). V-Color :







|                |  |          |        |
|----------------|--|----------|--------|
| Document Title | HSD190ME12-A Preliminary specification | Page No. | 17 /28 |
| Document No.   |  | Revision | 0.1    |

2). Mosaic : Dot checker image

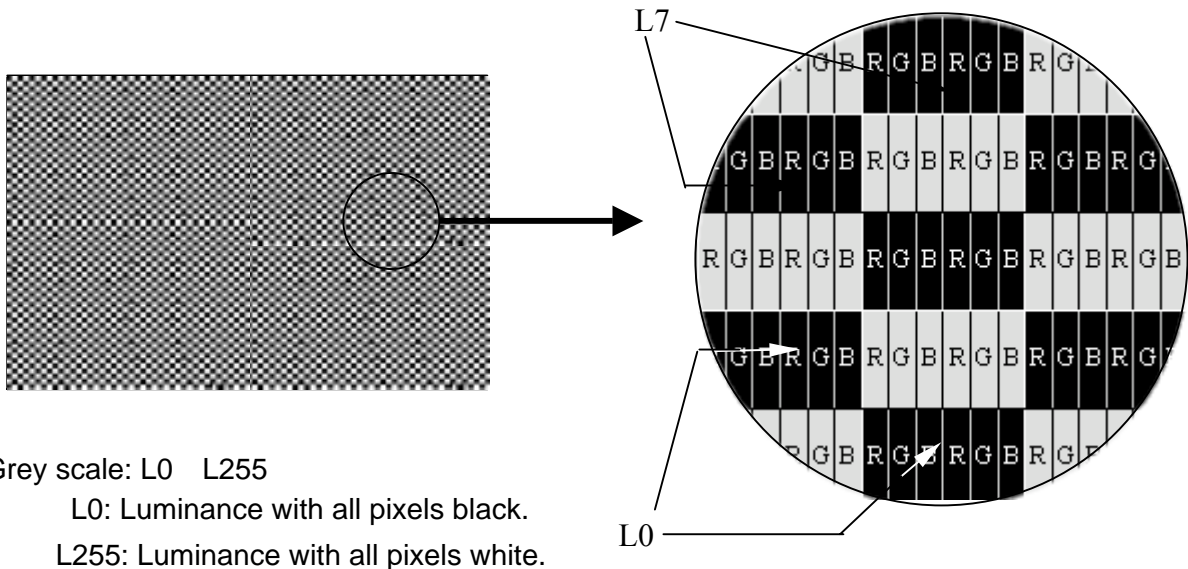

Note (2) When  $f_v$  is too low, a flicker may be occurred on the display.

Note (3) Input Rush Current condition

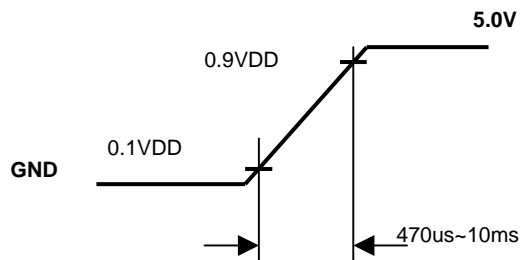

|                |  |          |        |
|----------------|--|----------|--------|
| Document Title | HSD190ME12-A Preliminary specification | Page No. | 18 /28 |
| Document No.   |  | Revision | 0.1    |

## 6.2 Back-Light Unit

The back-light system is an edge-lighting type with 4 CCFL(Cold Cathode Fluorescent Lamp). The characteristics of the lamp are shown in the following tables.

| Item                     | Symbol | Min. | Typ.  | Max. | Unit    | Note        |
|--------------------------|--------|------|-------|------|---------|-------------|
| Lamp current             | IL     | 3.5  | 6.5   | 9.0  | mA(rms) | (1)         |
| Lamp voltage             | VL     | 630  | 700   | 770  | V(rms)  | $I_L=6.5mA$ |
| Frequency                | fL     | 40   | --    | 80   | KHz     | (2)         |
| Operating lamp life time | Hr     | --   | 50000 | --   | Hour    | (3)         |
| Startup voltage          | Vs     | 1210 | --    | --   | V(rms)  | at 25°C     |
|                          |        | 1430 |       | -    |         | at 0°C      |

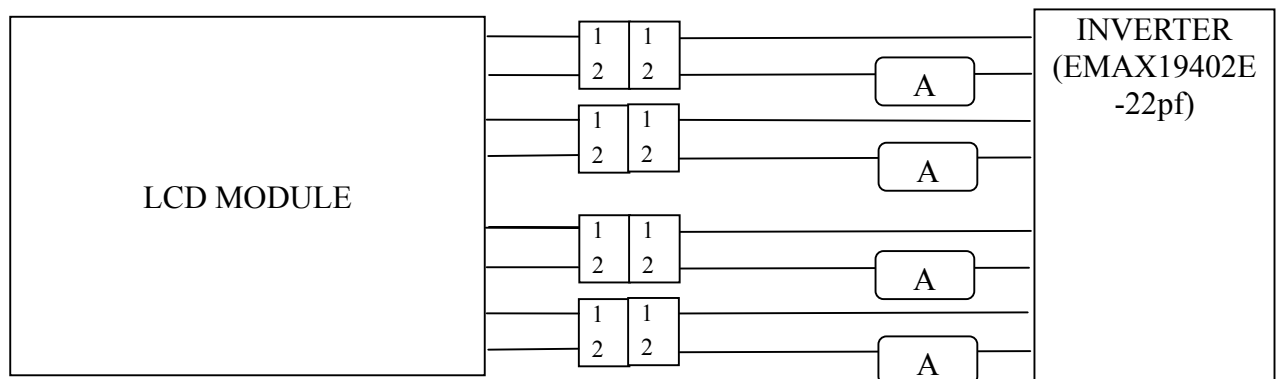

### Note (1)

Lamp current is measured with current meter for high frequency as shown below. Specified values are for a single lamp. To exceed 6.5.0mA, life time accelerate drop down and if to exceed 9.0 mA has safety problem. If current lower than 3.5 mA, CCFL would be unstable or damaged.

### Note (2)

Lamp frequency may produce interference with horizontal synchronous frequency and this may cause ripple noise on the display. Therefore lamp frequency shall be kept away from the horizontal synchronous frequency and its harmonics as far as possible in order to avoid interference.

### Note (3)

Lamp life time (Hr) can be defined as the time in which it continues to operate under the condition :  $T_a=25\pm 3^\circ C$ , Typical IL value indicated in the above table and  $f_L= --$  kHz until the brightness becomes less than 50%

|                |  |          |        |
|----------------|--|----------|--------|
| Document Title | HSD190ME12-A Preliminary specification | Page No. | 19 /28 |
| Document No.   |  | Revision | 0.1    |

## Note (4)

CCFL inverter should be able to provide a voltage over specified value ( $V_s$ ) in the above table. Lamp units need at least  $V_s$  value shown above to ignition.

## Note (5)

The voltage over specified value ( $V_s$ ) should be applied to the lamp more than 1 second after startup. Otherwise, the lamp may not be turned on. The used lamp current is the lamp typical current.

## Note (6)

The output voltage waveform and current waveform of the inverter must be symmetrical (Unsymmetrical ratio is less than 10%). Please do not use the inverter which has unsymmetrical voltage and current waveform, and spike waveform. The inverter design which can provide the best optical performance, power efficiency, and lamp life should under the following conditions.

- The asymmetry rate of the inverter waveform should be less than 10%.
- The distortion rate of the waveform should be within  $2 \pm 10\%$ .
- The inverter output waveform should be better similar to the ideal sine wave.

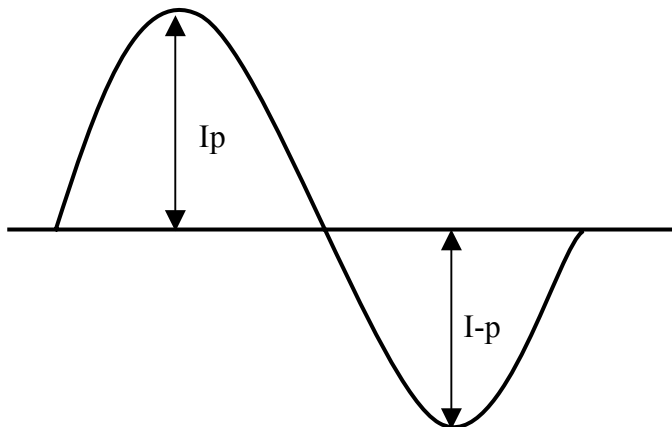

$$\text{Asymmetry rate} = |I_p - I-p| / I_{rms} \times 100\%$$

$$\text{Distortion rate} = I_p \text{ (or } I-p) / I_{rms}$$



|                |  |          |        |
|----------------|--|----------|--------|
| Document Title | HSD190ME12-A Preliminary specification | Page No. | 20 /28 |
| Document No.   |  | Revision | 0.1    |

### 6.3 Interface Timing ( DE mode) 1)2)3)4)5)6)

| Item                     | Symbol | Min. | Typ.  | Max.  | Unit  |
|--------------------------|--------|------|-------|-------|-------|
| Frame Period             | t1     | 1028 | 1066  | 1150  | line  |
| Vertical Display Time    | t2     | 1024 | 1024  | 1024  | line  |
| Vertical Blanking Time   | t3     | 4    |       |       | line  |
| 1 Line Scanning Time     | t4     | 720  | 844   | 875   | clock |
| Horizontal Display Time  | t5     | 640  | 640   |       | clock |
| Horizontal Blanking Time | t6     | 80   |       |       | clock |
| Clock Period             | t7     | 14.8 | 18.52 | 19.62 | ns    |

#### Timing Diagram of Interface Signal (DE mode)

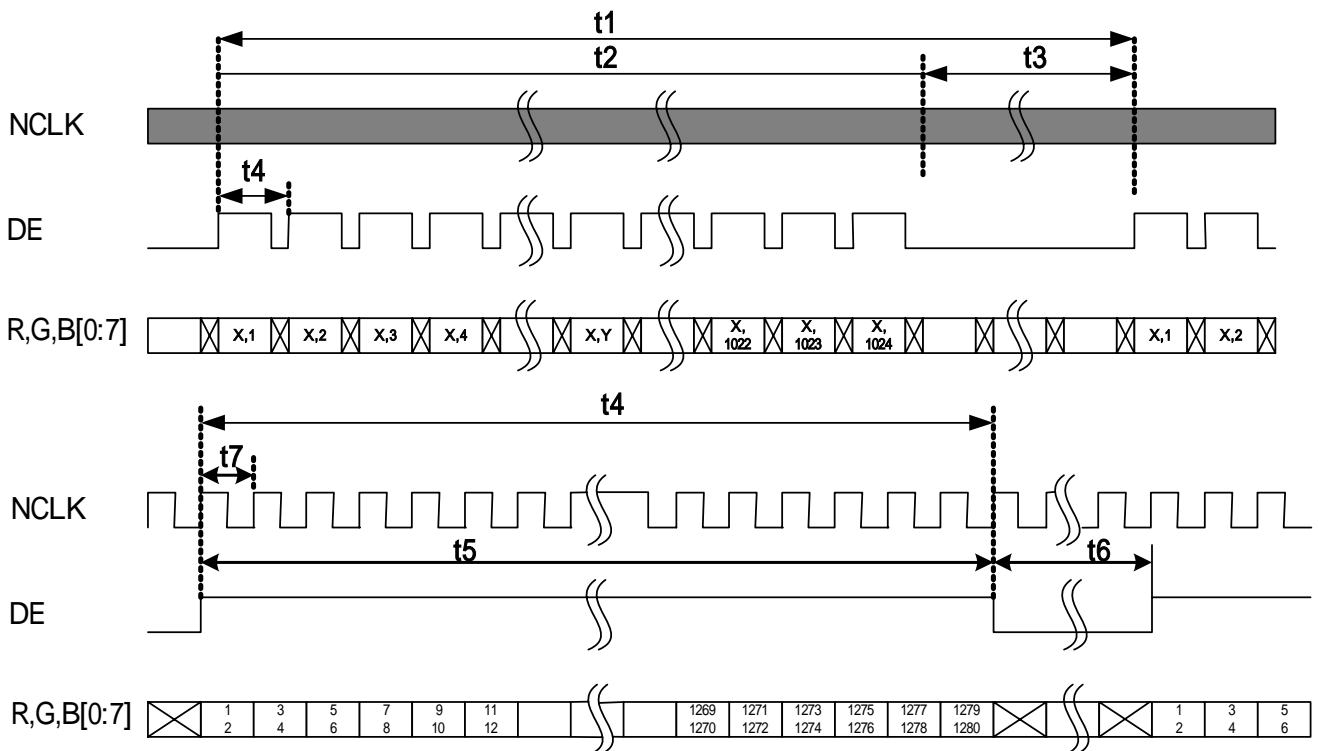

|                |  |          |        |
|----------------|--|----------|--------|
| Document Title | HSD190ME12-A Preliminary specification | Page No. | 21 /28 |
| Document No.   |  | Revision | 0.1    |

## 7.0 Input Timing Spec

### 7.1 Power On / Off Sequence :

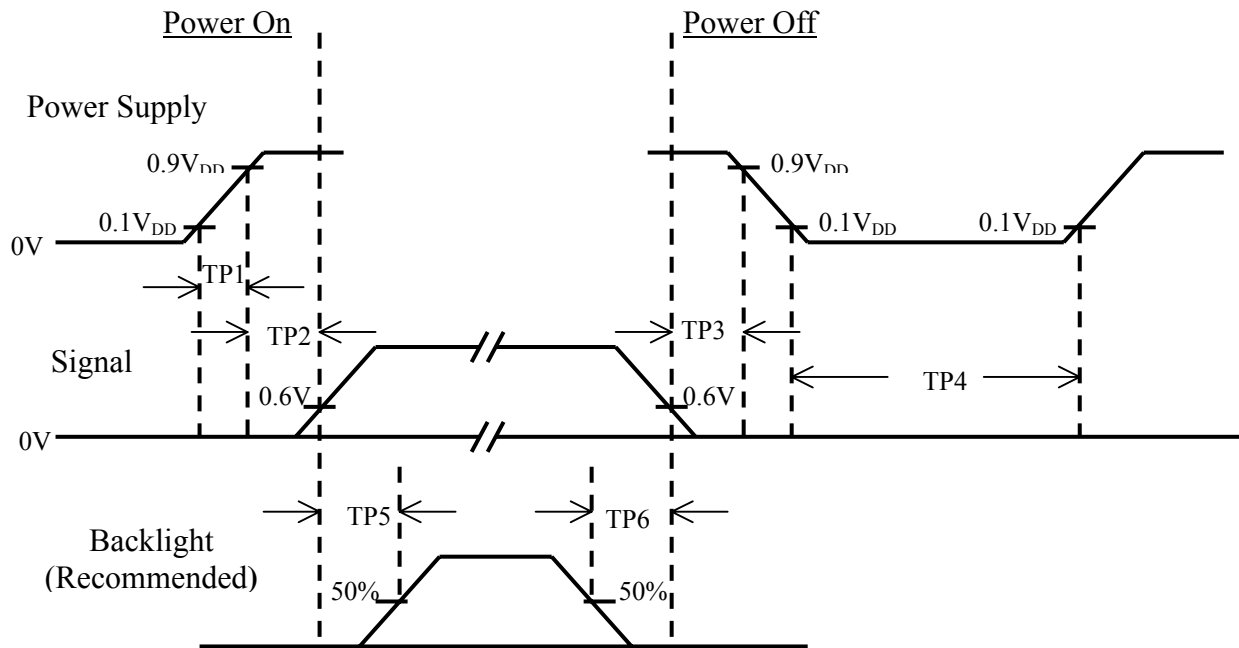

| Item | Min. | Typ. | Max. | Unit | Remark |
|------|------|------|------|------|--------|
| TP1  | 0.4  | -    | 10   | msec |        |
| TP2  | 50   | -    | --   | msec |        |
| TP3  | 0    | -    | 50   | msec |        |
| TP4  | 1    | -    | -    | sec  |        |
| TP5  | 200  | -    | -    | msec |        |
| TP6  | 200  | -    | -    | msec |        |

Note : (1) The supply voltage of the external system for the module input should be the same as the definition of V<sub>DD</sub>.

- (2) Apply the lamp voltage within the LCD operation range. When the back-light turns on before the LCD operation or the LCD turns off before the back-light turns off, the display may momentarily become white.
- (3) In case of V<sub>DD</sub> = off level, please keep the level of input signal on the low or keep a high impedance.
- (4) T4 should be measured after the module has been fully discharged between power off and on period.
- (5) Interface signal shall not be kept at high impedance when the power is on.





HannStar Display Corp.

|                |  |          |        |
|----------------|--|----------|--------|
| Document Title | HSD190ME12-A Preliminary specification | Page No. | 23 /28 |
| Document No.   |  | Revision | 0.1    |

**8.2 Back View :**

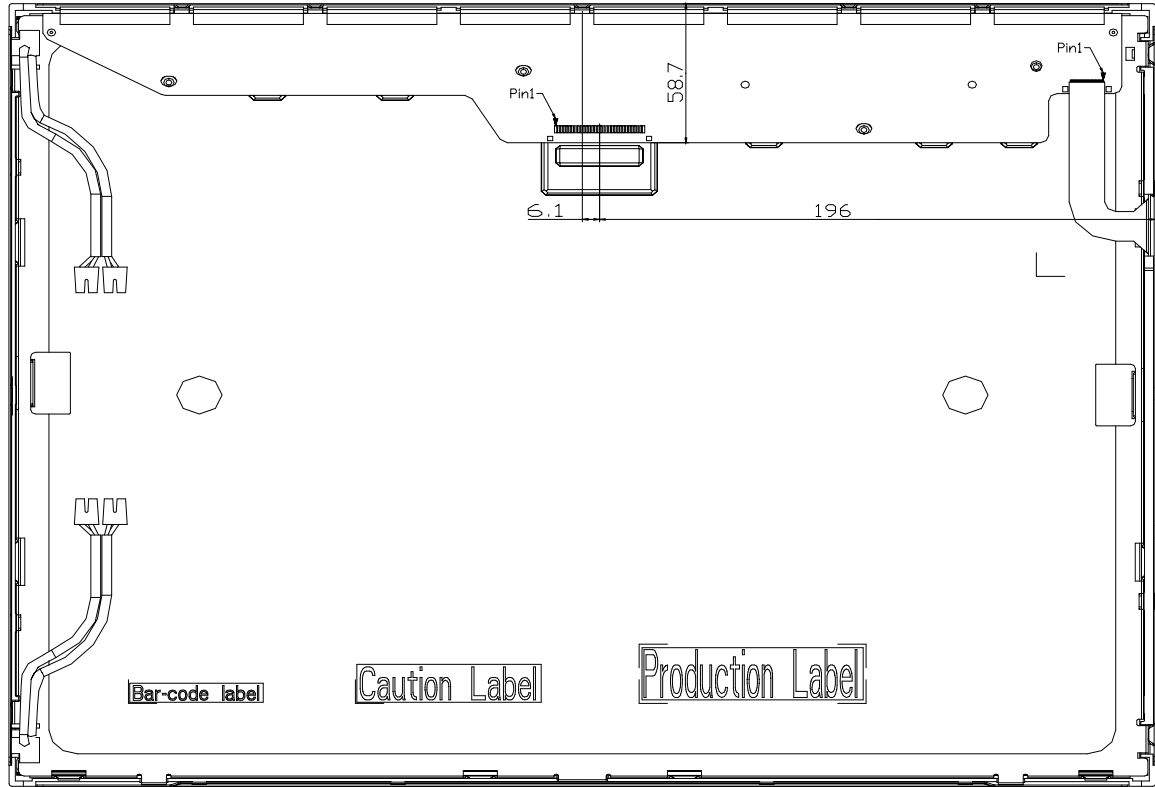



HannStar Display Corp.

|                |  |          |        |
|----------------|--|----------|--------|
| Document Title | HSD190ME12-A Preliminary specification | Page No. | 24 /28 |
| Document No.   |  | Revision | 0.1    |

## 9.0 LOT MARK

### 9.1 Lot Mark

|   |   |   |   |   |   |   |   |   |    |    |    |    |    |    |
|---|---|---|---|---|---|---|---|---|----|----|----|----|----|----|
| 1 | 2 | 3 | 4 | 5 | 6 | 7 | 8 | 9 | 10 | 11 | 12 | 13 | 14 | 15 |
|---|---|---|---|---|---|---|---|---|----|----|----|----|----|----|

code 1,2,3,4,5,6: HannStar internal flow control code.

code 7: production location.

code 8: production year.

code 9: production month.

code 10,11,12,13,14,15: serial number.

#### Note (1) Production Year

|      |      |      |      |      |      |      |      |      |      |      |
|------|------|------|------|------|------|------|------|------|------|------|
| Year | 1999 | 2000 | 2001 | 2002 | 2003 | 2004 | 2005 | 2006 | 2007 | 2008 |
| Mark | 9    | 0    | 1    | 2    | 3    | 4    | 5    | 6    | 7    | 8    |

#### Note (2) Production Month

|       |      |      |      |      |      |      |      |      |      |     |      |      |
|-------|------|------|------|------|------|------|------|------|------|-----|------|------|
| Month | Jan. | Feb. | Mar. | Apr. | May. | Jun. | Jul. | Aug. | Sep. | Oct | Nov. | Dec. |
| Mark  | 1    | 2    | 3    | 4    | 5    | 6    | 7    | 8    | 9    | A   | B    | C    |

### 9.2 Sub Model Code

|   |   |   |
|---|---|---|
| 1 | 2 | 3 |
|---|---|---|

code 1: Panel sub model code of type. (A~Z)

code 2,3: Panel product sub model code of serial number.  
(00~99)





HannStar Display Corp.

|                |  |          |        |
|----------------|--|----------|--------|
| Document Title | HSD190ME12-A Preliminary specification | Page No. | 25 /28 |
| Document No.   |  | Revision | 0.1    |

### 9.3 Location of Lot Mark

- (1) The label is attached to the backside of the LCD module.
- (2) This is subject to change without prior notice.

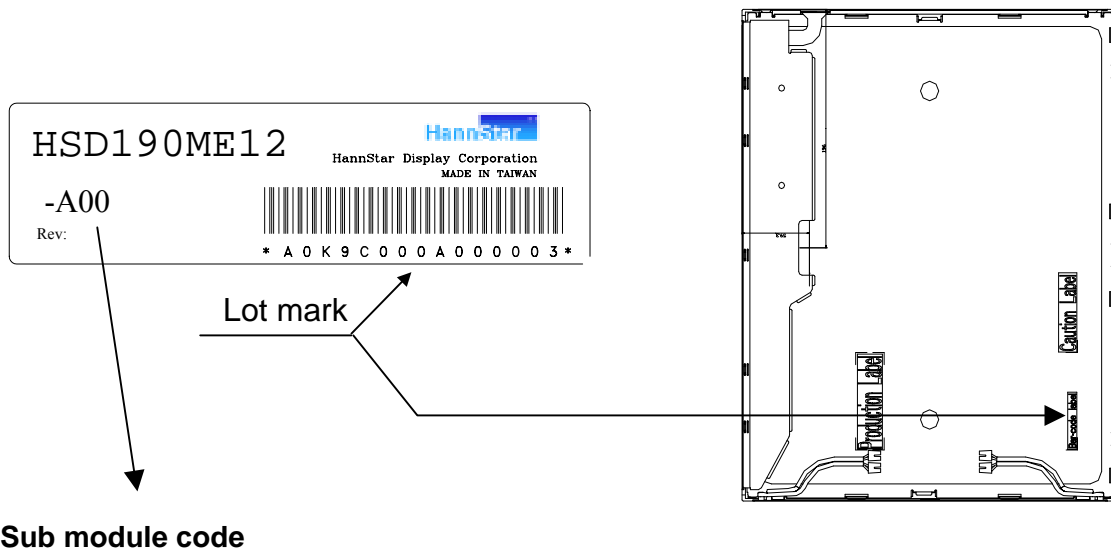



HannStar Display Corp.

|                |  |          |        |
|----------------|--|----------|--------|
| Document Title | HSD190ME12-A Preliminary specification | Page No. | 26 /28 |
| Document No.   |  | Revision | 0.1    |

### 10.0 PACKAGE SPECIFICATION

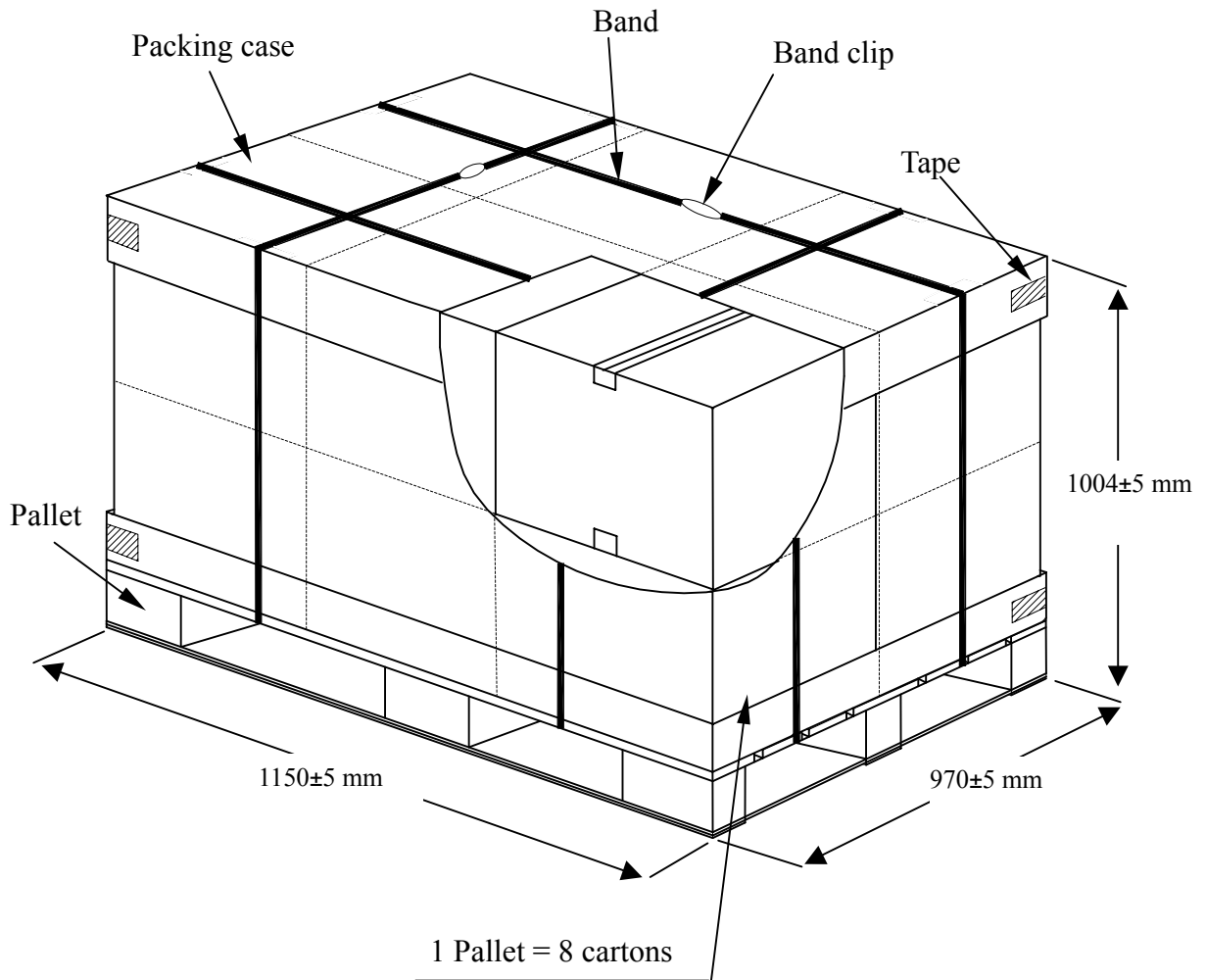



|                |  |          |        |
|----------------|--|----------|--------|
| Document Title | HSD190ME12-A Preliminary specification | Page No. | 27 /28 |
| Document No.   |  | Revision | 0.1    |

## 11.0 GENERAL PRECAUTION

### 11.1 Use Restriction

This product is not authorized for use in life supporting systems, aircraft navigation control systems, military systems and any other application where performance failure could be life-threatening or otherwise catastrophic.

### 11.2 Disassembling or Modification

Do not disassemble or modify the module. It may damage sensitive parts inside LCD module, and may cause scratches or dust on the display. HannStar does not warrant the module, if customers disassemble or modify the module.

### 11.3 Breakage of LCD Panel

11.3.1 If LCD panel is broken and liquid crystal spills out, do not ingest or inhale liquid crystal, and do not contact liquid crystal with skin.

11.3.2 If liquid crystal contacts mouth or eyes, rinse out with water immediately.

11.3.3 If liquid crystal contacts skin or cloths, wash it off immediately with alcohol and rinse thoroughly with water.

11.3.4 Handle carefully with chips of glass that may cause injury, when the glass is broken.

### 11.4 Electric Shock

11.4.1 Disconnect power supply before handling LCD module.

11.4.2 Do not pull or fold the CCFL cable.

11.4.3 Do not touch the parts inside LCD modules and the fluorescent lamp's connector or cables in order to prevent electric shock.

### 11.5 Absolute Maximum Ratings and Power Protection Circuit

11.5.1 Do not exceed the absolute maximum rating values, such as the supply voltage variation, input voltage variation, variation in parts' parameters, environmental temperature, etc., otherwise LCD module may be damaged.

11.5.2 Please do not leave LCD module in the environment of high humidity and high temperature for a long time.

11.5.3 It's recommended employing protection circuit for power supply.

### 11.6 Operation

11.6.1 Do not touch, push or rub the polarizer with anything harder than HB pencil lead.

Use fingerstalls of soft gloves in order to keep clean display quality, when persons

11.6.2 handle the LCD module for incoming inspection or assembly.

11.6.3 When the surface is dusty, please wipe gently with absorbent cotton or other soft material.

11.6.4 Wipe off saliva or water drops as soon as possible. If saliva or water drops contact with polarizer for a long time, they may causes deformation or color fading.

11.6.5 When cleaning the adhesives, please use absorbent cotton wetted with a little petroleum benzine or other adequate solvent.



|                |  |          |        |
|----------------|--|----------|--------|
| Document Title | HSD190ME12-A Preliminary specification | Page No. | 28 /28 |
| Document No.   |  | Revision | 0.1    |

**11.7 Mechanism**

Please mount LCD module by using mounting holes arranged in four corners tightly.

**11.8 Static Electricity**

11.8.1 Protection film must remove very slowly from the surface of LCD module to prevent from electrostatic occurrence.

11.8.2 Because LCD module uses CMOS-IC on circuit board and TFT-LCD panel, it is very weak to electrostatic discharge. Please be careful with electrostatic discharge.

11.8.3 Persons who handle the module should be grounded through adequate methods.

**11.9 Strong Light Exposure**

The module shall not be exposed under strong light such as direct sunlight. Otherwise, display characteristics may be changed.

**11.10 Disposal**

When disposing LCD module, obey the local environmental regulations.