



HannStar Display Corp.

Document Title	HSD190ME12- A Product Information	Page No.	1 / 29
Document No.		Revision	1.0

Hannstar Product Information

Model : **HSD190ME12**
- A10

- Note:
1. Please contact HannStar Display Corp. before designing your product based on this module specification.
 2. The information contained herein is presented merely to indicate the characteristics and performance of our products. No responsibility is assumed by HannStar for any intellectual property claims or other problems that may result from application based on the module described herein.

The information contained in this document is the exclusive property of HannStar Display Corporation. It shall not be disclosed, distributed or reproduced in whole or in part without written permission of HannStar Display Corporation.



HannStar Display Corp.

Document Title	HSD190ME12- A Product Information	Page No.	2 / 29
Document No.		Revision	1.0

Record of Revisions

Rev.	Updated No.	Date	Description of change
1.0	—	July 11, 2005	HSD190ME12-A product information was first issued.

The information contained in this document is the exclusive property of HannStar Display Corporation. It shall not be disclosed, distributed or reproduced in whole or in part without written permission of HannStar Display Corporation.



HannStar Display Corp.

Document Title	HSD190ME12- A Product Information	Page No.	3 / 29
Document No.		Revision	1.0

Contents

1.0	General descriptions	p.4
2.0	Absolute maximum ratings	p.5
3.0	Optical characteristics	p.7
4.0	Block diagram	p.12
5.0	I/O Connection Pin assignment	p.15
6.0	Electrical Characteristics	p.16
7.0	Input Timing Spec.....	p.21
8.0	Outline dimension	p.22
9.0	Lot Mark	p.24
10.0	Package Specification	p.26
11.0	General precaution	p.28



Document Title	HSD190ME12- A Product Information	Page No.	4 / 29
Document No.		Revision	1.0

1.0 GENERAL DESCRIPTIONS

1.1 Introduction

HannStar Display model **HSD190ME12** is a color active matrix thin film transistor (TFT) liquid crystal display (LCD) that uses amorphous silicon TFT as a switching device. This model is composed of a TFT LCD panel, the voltage reference, common voltage, DC-DC converter, column, and row driver circuit. This TFT LCD has a 19-inch diagonally measured active display area with SXGA resolution (1024 vertical by 1280 horizontal pixel array).

1.2 Features

- 19" SXGA TFT LCD panel
- 4 CCFLs Backlight system
- Supported SXGA (V:1024 lines, H:1280 pixels) resolution
- Supported to 75Hz refresh rate
- LCD Timing Controller
- Compatible with RoHS standard

1.3 General information

Item	Specification		Unit
Outline dimension	404.2(H) X 330(V) X 19.0 (typ.)		mm
Display area	376.32(W) x 301.056(H) (19.0" diagonal)		mm
Number of Pixel	1280(H) x 1024(V)		Pixels
Pixel pitch	0.294(H) x 0.294(V)		mm
Pixel arrangement	RGB Vertical stripe		
Display color	16.2M (6-bits+FRC)		
Display mode	Normally white		
Surface treatment	Antiglare, Hard-Coating(3H)		
Weight	2350(typ.)		G
Back-light	4-CCFLs, Top & bottom edge side		
Input signal	2 -CH LVDS		
Power consumption (with B/L)	System	3	W
	B/L	22	
Optimum viewing direction	6 o'clock		

1.4 Applications

- Desktop monitors
- Display terminals for AV applications
- Monitors for industrial applications

Document Title	HSD190ME12- A Product Information	Page No.	5 / 29
Document No.		Revision	1.0

1.5 Mechanical Information

Item		Min.	Typ.	Max.	Unit
Module Size	Horizontal(H)	403.7	404.2	404.7	mm
	Vertical(V)	329.5	330	330.5	mm
	Depth(D)	18.5	19	19.5	mm
Weight (without inverter)		2230	2350	2470	g
Torque of customer screw hole				3.0	Kgf*Cm

2.0 ABSOLUTE MAXIMUM RATINGS

2.1 Absolute Rating of Environment

Item	Symbol	Min.	Max.	Unit	Note
Storage temperature	T _{STG}	-20	60	°C	
Operating temperature	T _{OPR}	0	50	°C	(1)
Vibration(non-operating)	V _{NOP}	--	1.5	G	(2)
Shock(non-operating)	S _{NOP}	--	70	G	(3)
Storage humidity	H _{STG}	10	90	%RH	(3)
Operating humidity	H _{OP}	10	80	%RH	(4)
Low pressure(operating)	P _{LOP}	697	--	HPa	(5)
Low pressure(non-operating)	P _{LNOP}	116	--	HPa	(6)

Note (1)Storage /Operating temperature

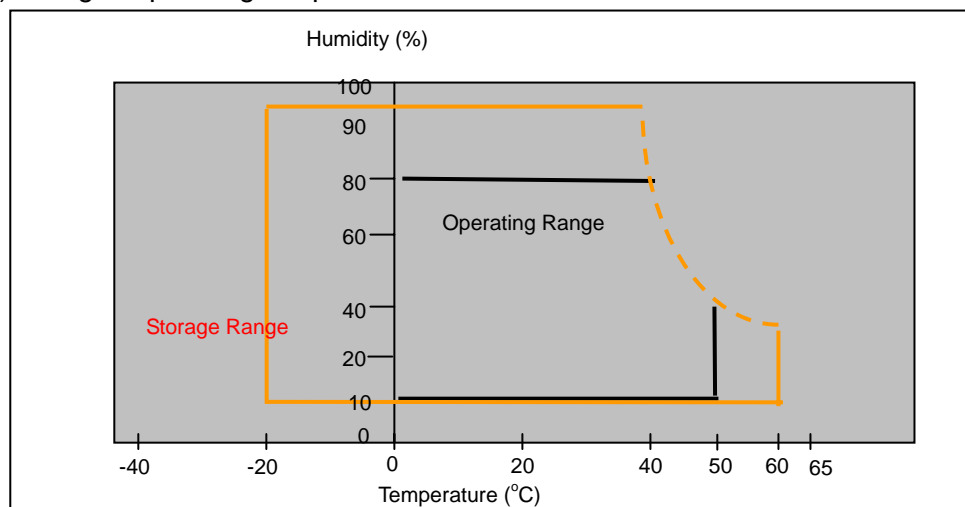



Document Title	HSD190ME12- A Product Information	Page No.	6 / 29
Document No.		Revision	1.0

- (2) 5-500 Hz sine wave, X,Y,Z each directions, 30 min/cycle.
- (3) 11ms, $\pm X$, $\pm Y$, $\pm Z$ direction, one time each. For this shock test,
It is necessary to fill the silicon rubber between the shock jig as buffer.
- (4) Max wet bulb temp. =39°C
- (5) 2 hrs. (10000 feet)
- (6) 24hrs. (50000 feet)

2.2 Electrical Absolute Rating:

2.2.1 TFT LCD Module:

Item	Symbol	Min.	Max.	Unit.	Note
Power supply Voltage	V_{DD}	-0.3	5.5	V(DC)	(1)(2)

2.2.2 Back Light Unit:

Item	Symbol	Min.	Max.	Unit	Note
Lamp current	I_L	3.5	9.0	mA	(1)(2)
Lamp frequency	f_L	40	80	KHz	(1)(2)

Note: (1) Permanent damage may occur to the LCD module if beyond this specification.

Functional operation should be restricted to the conditions described under Normal Operating Conditions.

- (2) To exceed 6.5mA, life time accelerate drop down and if to exceed 9.0 mA has safety problem. If current is lower than 3.5 mA, CCFL would be unstable or damaged.
- (3) Within $T_a=25\pm 2^\circ\text{C}$.



Document Title	HSD190ME12- A Product Information	Page No.	7 / 29
Document No.		Revision	1.0

3.0 OPTICAL CHARACTERISTICS

3.1 Optical specification

Item	Symbol	Condition	Min.	Typ.	Max.	Unit	Note
Contrast	CR		450	700	--		(1)(2)
Response time	Rising	TR	--	2	7	msec	(1)(3)
	Falling	TF		6	11		
White luminance (center of screen)	Y_L	$\Theta=0^\circ$	200	250		cd/m ²	(1)(4) (IL=6.5mA)
Color chromaticity (CIE1931)	Red	Rx	$\phi=0^\circ$ Normal viewing angle	0.617	0.647	0.677	(1)(4)
		Ry		0.297	0.327	0.357	
	Green	Gx		0.262	0.292	0.322	
		Gy		0.584	0.614	0.644	
	Blue	Bx		0.112	0.142	0.172	
		By		0.049	0.079	0.109	
	White	Wx		0.280	0.310	0.340	
		Wy		0.300	0.330	0.360	
Viewing angle	Hor.	Θ_L	CR>10	60	75	--	
		Θ_R		60	75	--	
	Ver.	Θ_H		55	70	--	
		Θ_L		55	65	--	
Viewing angle	Hor.	Θ_L	CR>5	--	80	--	
		Θ_R		--	80	--	
	Ver.	Θ_H		--	75	--	
		Θ_L		--	75	--	
Brightness uniformity	B_{UNI}	$\Theta=0^\circ$	75	80	--	%	(6)
Crosstalk	CT(n)	$\phi=0^\circ$	--	--	1.3	%	(7)

3.2 Measuring Condition

- Measuring surrounding : dark room
- Lamp current I_{BL} : (6.5)±0.1mA, lamp freq. $F_L=48$ KHz, Inverter :EMAX19402E(22pf)
- $V_{DD1}=5.0V$, $f_V=60Hz$, $f_{DCLK}=54MHz$
- Surrounding temperature : 25±2°C
- 30min. Warm-up time.

Document Title	HSD190ME12- A Product Information	Page No.	8 / 29
Document No.		Revision	1.0

3.3 Measuring Equipment

- MD-3000 of Otsuka Electric Corp., which utilized MCPD-7000 for Chromaticity and BM-5A for other optical characteristics.
- Measuring spot size : 10~12mm

Note (1) Definition of Viewing Angle:

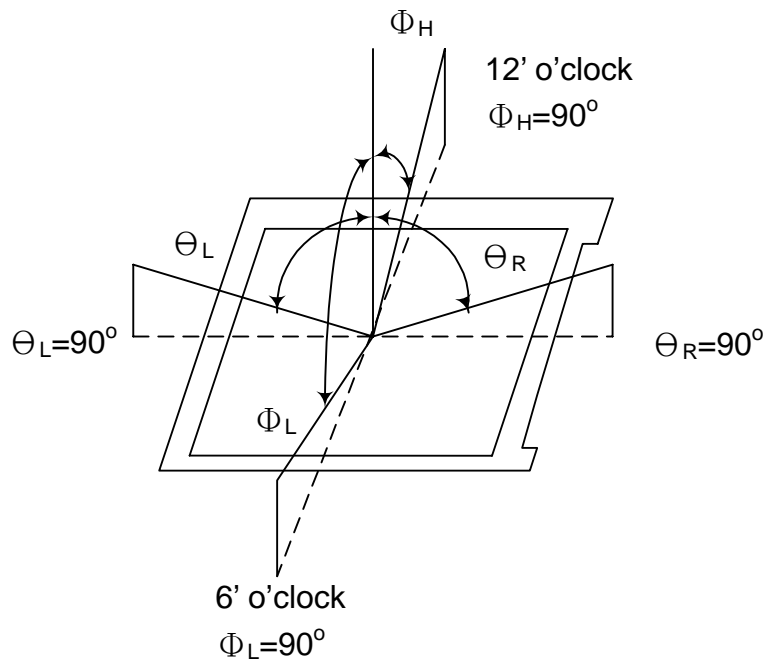

Note (2) Definition of Contrast Ratio(CR) :
measured at the center point of panel

$$CR = \frac{\text{Luminance with all pixels white (L}_{255}\text{)}}{\text{Luminance with all pixels black (L}_0\text{)}}$$

Document Title	HSD190ME12- A Product Information	Page No.	9 / 29
Document No.		Revision	1.0

Note (3) Definition of Response Time: Sum of T_R and T_F

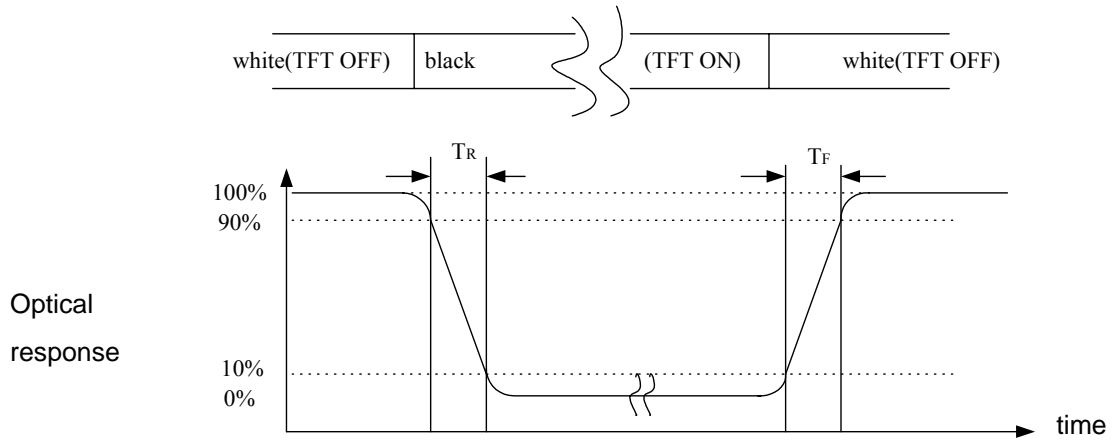

Note (4) Optical characteristic measurement setup

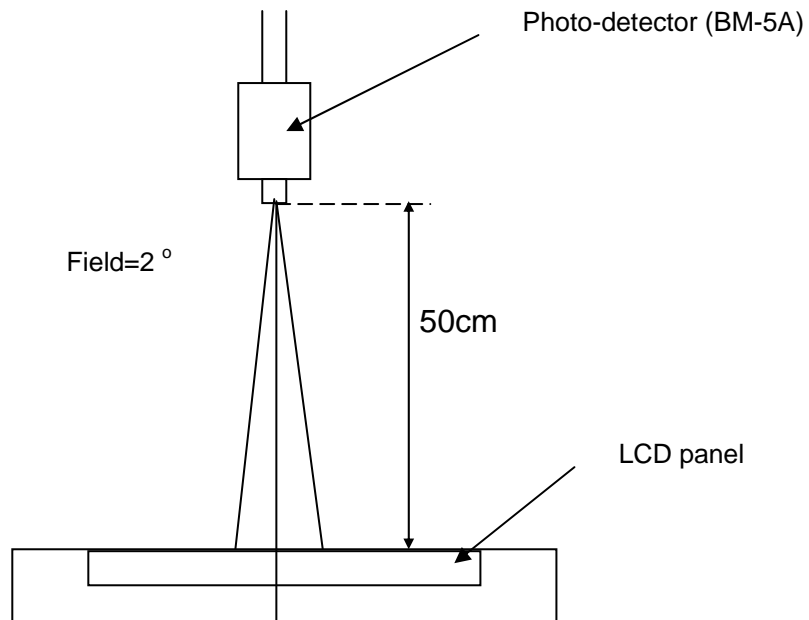



Document Title	HSD190ME12- A Product Information	Page No.	10 / 29
Document No.		Revision	1.0

Note (5) Definition of Center Luminance of White

Center Luminance= Y1

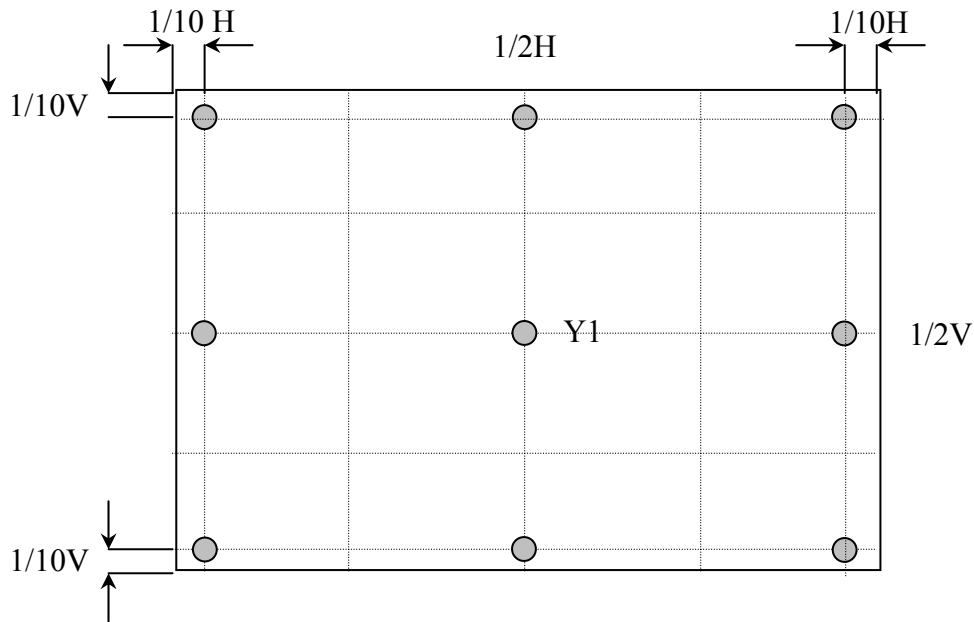

Note (6) Definition of brightness uniformity

$$\text{Luminance uniformity} = \frac{(\text{Min Luminance of 9 points})}{(\text{Max Luminance of 9 points})} \times 100\%$$



Document Title	HSD190ME12- A Product Information	Page No.	11 /29
Document No.		Revision	1.0

Note (7) Definition of crosstalk CT (1) ~ CT (4)

$$CT(n) = \frac{|L(n) - LB(n)|}{L(n)} \times 100\% , n = 1 \sim 4$$

Where L(n) = Luminance of point “n” at pattern A (cd/m²) , n=1~4

LB(n) = Luminance of point “n” at pattern B (cd/m²) , n=1~4

The location measured will be exactly the same in both patterns.

L0: Luminance with all pixels black

L255: Luminance with all pixels white

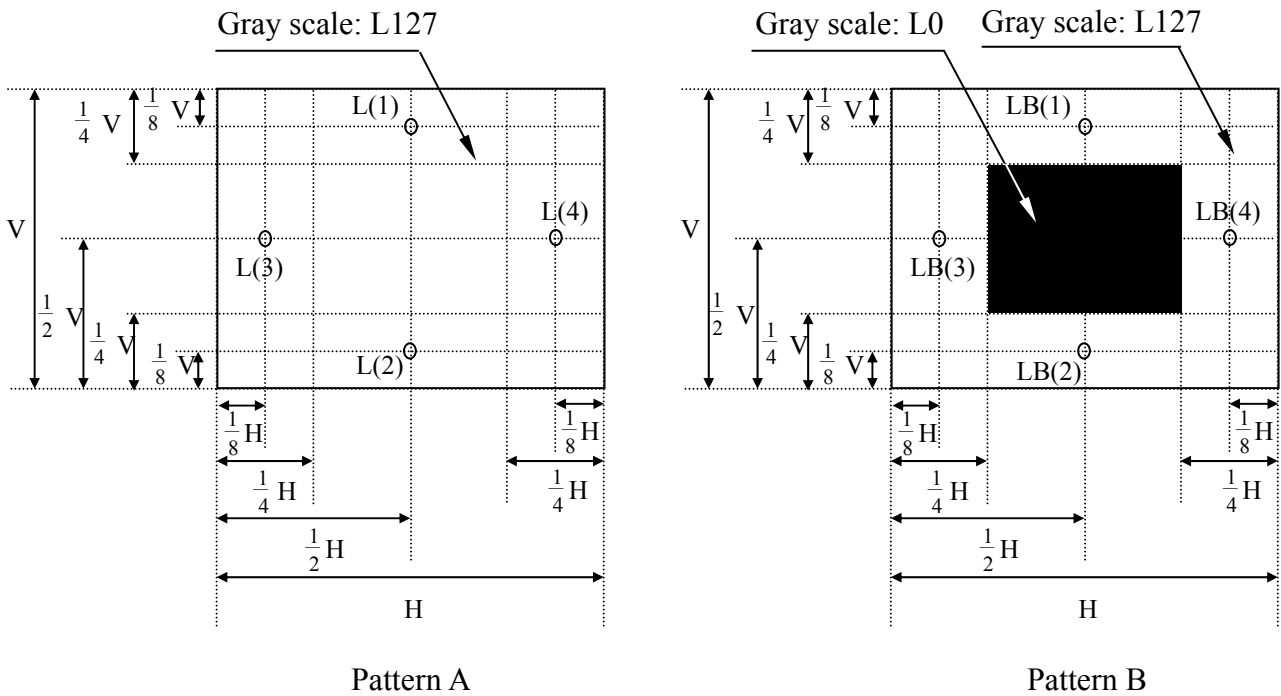



Document Title	HSD190ME12- A Product Information	Page No.	12 /29
Document No.		Revision	1.0

4.0 BLOCK DIAGRAM

4.1 LCD Module Block Diagram:

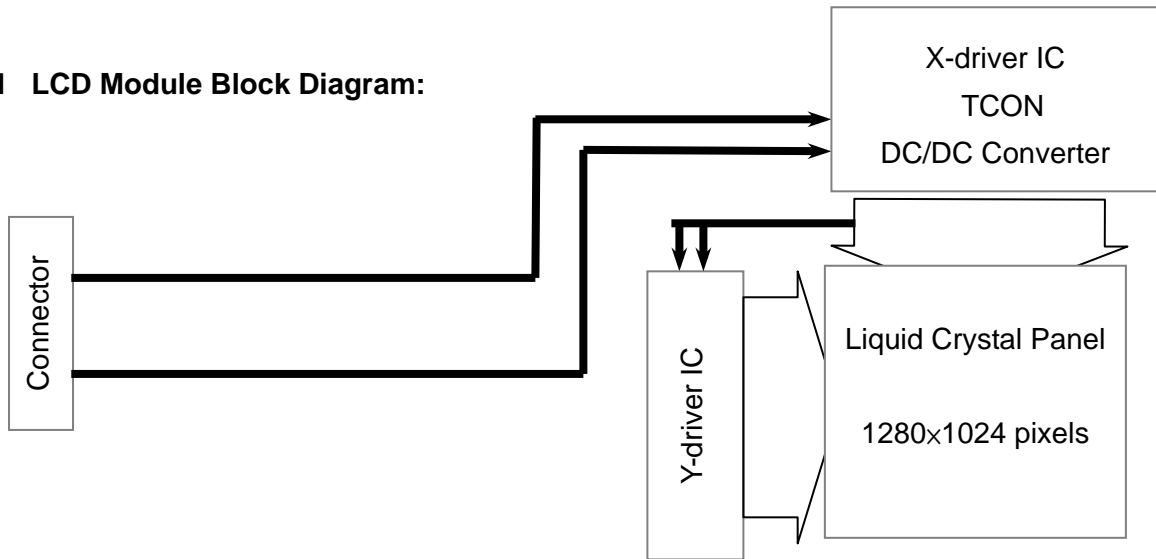



Document Title	HSD190ME12- A Product Information	Page No.	13 /29
Document No.		Revision	1.0

4.2 Back Light Unit

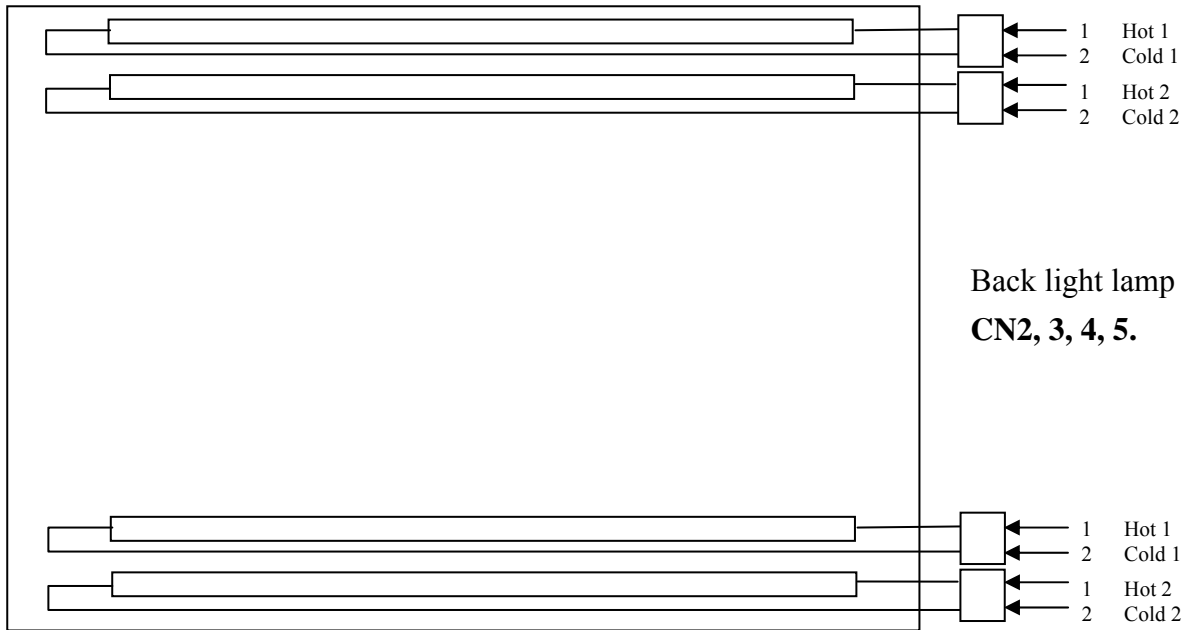

4.3 Pixel Format

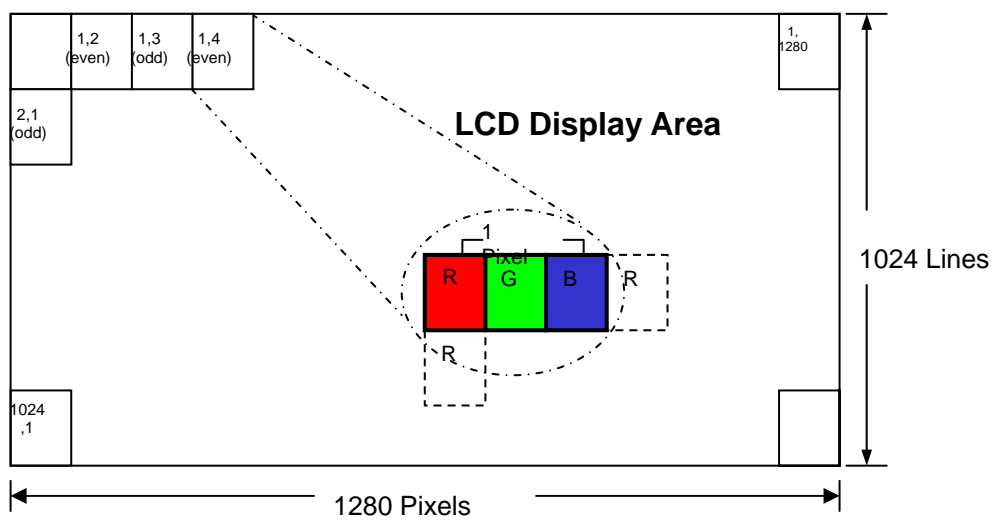



Document Title	HSD190ME12- A Product Information	Page No.	14 /29
Document No.		Revision	1.0

4.4 Relationship Between Displayed Color and Input

Display	MSB				LSB				MSB				LSB				MSB				LSB				Gray scale Level	
	R7	R6	R5	R4	R3	R2	R1	R0	G7	G6	G5	G4	G3	G2	G1	G0	B7	B6	B5	B4	B3	B2	B1	B0		
Basic color	Black	L	L	L	L	L	L	L	L	L	L	L	L	L	L	L	L	L	L	L	L	L	L	L	L	-
	Blue	L	L	L	L	L	L	L	L	L	L	L	L	L	L	L	L	H	H	H	H	H	H	H	H	-
	Green	L	L	L	L	L	L	L	L	H	H	H	H	H	H	H	H	L	L	L	L	L	L	L	L	-
	Light Blue	L	L	L	L	L	L	L	L	H	H	H	H	H	H	H	H	H	H	H	H	H	H	H	H	-
	Red	H	H	H	H	H	H	H	H	L	L	L	L	L	L	L	L	L	L	L	L	L	L	L	L	-
	Purple	H	H	H	H	H	H	H	H	L	L	L	L	L	L	L	L	H	H	H	H	H	H	H	H	-
	Yellow	H	H	H	H	H	H	H	H	H	H	H	H	H	H	H	H	L	L	L	L	L	L	L	L	-
	White	H	H	H	H	H	H	H	H	H	H	H	H	H	H	H	H	H	H	H	H	H	H	H	H	-
Gray scale of Red	Black	L	L	L	L	L	L	L	L	L	L	L	L	L	L	L	L	L	L	L	L	L	L	L	L	L0
	Dark	L	L	L	L	L	L	L	H	L	L	L	L	L	L	L	L	L	L	L	L	L	L	L	L	L1
		L	L	L	L	L	L	L	L	L	L	L	L	L	L	L	L	L	L	L	L	L	L	L	L	L2
		:	:	:	:	:	:	:	:	:	:	:	:	:	:	:	:	:	:	:	:	:	:	:	L3...L251	
	Light	H	H	H	H	H	L	H	H	L	L	L	L	L	L	L	L	L	L	L	L	L	L	L	L	L255
		H	H	H	H	H	H	L	H	L	L	L	L	L	L	L	L	L	L	L	L	L	L	L	L	L255
		H	H	H	H	H	H	H	L	L	L	L	L	L	L	L	L	L	L	L	L	L	L	L	L	L255
	Red	H	H	H	H	H	H	H	H	L	L	L	L	L	L	L	L	L	L	L	L	L	L	L	L	Red L255
Gray scale of Green	Black	L	L	L	L	L	L	L	L	L	L	L	L	L	L	L	L	L	L	L	L	L	L	L	L	L0
	Dark	L	L	L	L	L	L	L	L	L	L	L	L	L	L	L	H	L	L	L	L	L	L	L	L	L1
		L	L	L	L	L	L	L	L	L	L	L	L	L	L	H	L	L	L	L	L	L	L	L	L	L2
		:	:	:	:	:	:	:	:	:	:	:	:	:	:	:	:	:	:	:	:	:	:	:	L3...L251	
	Light	L	L	L	L	L	L	L	L	H	H	H	H	H	L	H	H	L	L	L	L	L	L	L	L	L255
		L	L	L	L	L	L	L	L	H	H	H	H	H	H	L	H	L	L	L	L	L	L	L	L	L255
		L	L	L	L	L	L	L	L	H	H	H	H	H	H	H	L	L	L	L	L	L	L	L	L	L255
	Green	L	L	L	L	L	L	L	L	H	H	H	H	H	H	H	H	L	L	L	L	L	L	L	L	Green L255
Gray scale of Blue	Black	L	L	L	L	L	L	L	L	L	L	L	L	L	L	L	L	L	L	L	L	L	L	L	L	L0
	Dark	L	L	L	L	L	L	L	L	L	L	L	L	L	L	L	L	L	L	L	L	L	L	L	H	L1
		L	L	L	L	L	L	L	L	L	L	L	L	L	L	L	L	L	L	L	L	L	L	H	L	L2
		:	:	:	:	:	:	:	:	:	:	:	:	:	:	:	:	:	:	:	:	:	:	:	L3...L251	
	Light	L	L	L	L	L	L	L	L	L	L	L	L	L	L	L	L	H	H	H	H	H	L	H	H	L255
		L	L	L	L	L	L	L	L	L	L	L	L	L	L	L	L	H	H	H	H	H	H	L	H	L255
		L	L	L	L	L	L	L	L	L	L	L	L	L	L	L	L	H	H	H	H	H	H	H	L	L255
	Blue	L	L	L	L	L	L	L	L	L	L	L	L	L	L	L	L	H	H	H	H	H	H	H	H	Blue L255
Gray scale of White & Black	Black	L	L	L	L	L	L	L	L	L	L	L	L	L	L	L	L	L	L	L	L	L	L	L	L	L0
	Dark	L	L	L	L	L	L	L	H	L	L	L	L	L	L	H	L	L	L	L	L	L	L	H	L1	
		L	L	L	L	L	L	L	H	L	L	L	L	L	H	L	L	L	L	L	L	H	L	L2		
		:	:	:	:	:	:	:	:	:	:	:	:	:	:	:	:	:	:	:	:	:	:	:	L3...L251	
	Light	H	H	H	H	H	L	H	H	H	H	H	H	L	H	H	H	H	H	H	L	H	H	L255		
		H	H	H	H	H	H	L	H	H	H	H	H	H	L	H	H	H	H	H	H	L	H	L255		
		H	H	H	H	H	H	H	L	H	H	H	H	H	H	L	H	H	H	H	H	H	L	L255		
	White	H	H	H	H	H	H	H	H	H	H	H	H	H	H	H	H	H	H	H	H	H	H	H	H	White L255

The information contained in this document is the exclusive property of HannStar Display Corporation. It shall not be disclosed, distributed or reproduced in whole or in part without written permission of HannStar Display Corporation.



Document Title	HSD190ME12- A Product Information	Page No.	15 /29
Document No.		Revision	1.0

5.0 I/O CONNECTION PIN ASSIGNMENT

5.1 Interface Connector (30-pins) (JAE: FI-X30SSL-HF or equivalent)

Pin No.	Signal	Description
1	RinO0-	Receiver Signal (-)
2	RinO0+	Receiver Signal (+)
3	RinO1-	Receiver Signal (-)
4	RinO1+	Receiver Signal (+)
5	RinO2-	Receiver Signal (-)
6	RinO2+	Receiver Signal (+)
7	VSS	Ground
8	RinOC-	Clock Signal (-)
9	RinOC+	Clock Signal (+)
10	RinO3-	Receiver Signal (-)
11	RinO3+	Receiver Signal (+)
12	RinE0-	Receiver Signal (-)
13	RinE0+	Receiver Signal (+)
14	VSS	Ground
15	RinE1-	Receiver Signal (-)
16	RinE1+	Receiver Signal (+)
17	VSS	Ground
18	RinE2-	Receiver Signal (-)
19	RinE2+	Receiver Signal (+)
20	RinEC-	Clock Signal (-)
21	RinEC+	Clock Signal (+)
22	RinE3-	Receiver Signal (-)
23	RinE3+	Receiver Signal (+)
24	VSS	Ground
25	VSS	Ground
26	NC	NC
27	VSS	Ground
28	VDD+5V	Power Supply, 5V (Typical)
29	VDD+5V	Power Supply, 5V (Typical)
30	VDD+5V	Power Supply, 5V (Typical)

Note 1) Please connects NC pin & Test pin to nothing. Don't connect it to ground nor to other signal input.

Note 2) Please connects GND pin to ground. Don't use it as no-connect nor connect with high impedanc

5.2 Back Light Unit (CCFL) Connectors:

CN2, 3, 4, 5: CCFL Power Source (BHR-02VS-1)

Pin No.	Symbol	Color	Function
1	Hot1	Pink	CCFL power supply (High voltage)
2	Cold1	White	Ground

Document Title	HSD190ME12- A Product Information	Page No.	16 /29
Document No.		Revision	1.0

6.0 ELECTRICAL CHARACTERISTICS

6.1 TFT LCD Module:

Item	Symbol	Min.	Typ.	Max.	Unit	Note	
Voltage of power supply	V_{DD}	4.5	5.0	5.5	V		
Current of power supply	V-Color	I_{DD1}	330	430	530	mA	(1)(3)
	Mosaic	I_{DD2}	380	480	580	mA	(1)(3)
Vsync frequency	f_V	60	60	75	Hz	(2)(3)	
Hsync frequency	f_H	64	64	80	KHz		
Frequency	f_{DCLK}	50	54	67.5	MHz		
Input rush current	I_{RUSH}	---	---	3.0	A	(3)(4)	

Note (1)

1). V-Color :





Document Title	HSD190ME12- A Product Information	Page No.	17 /29
Document No.		Revision	1.0

2). Mosaic : Dot checker image

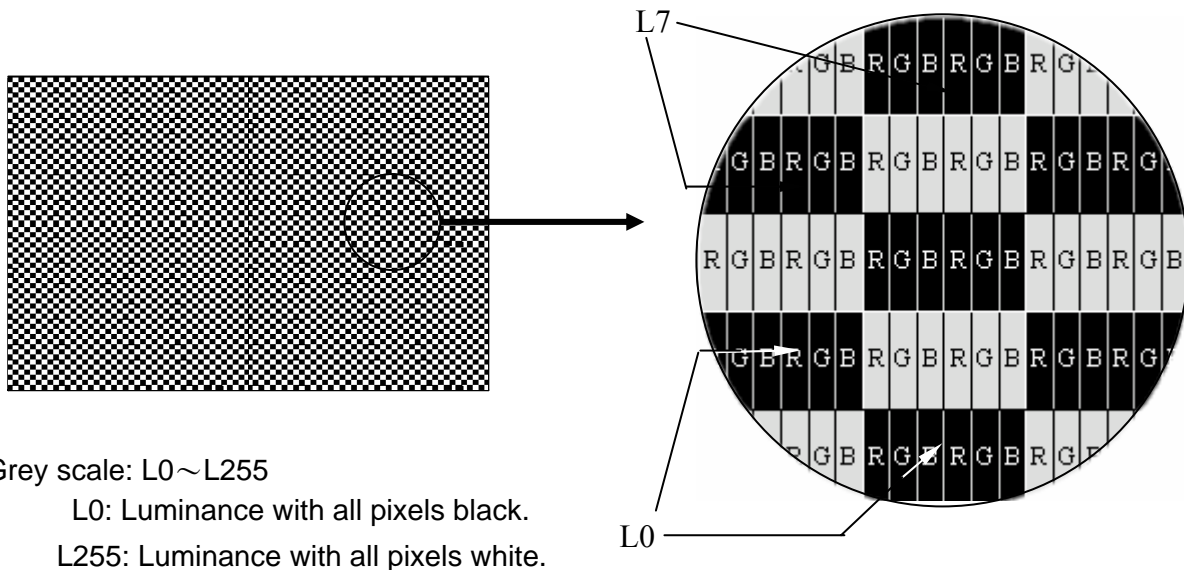

Note (2) When f_v is too low, a flicker may be occurred on the display.
 Note (3) Input Rush Current condition

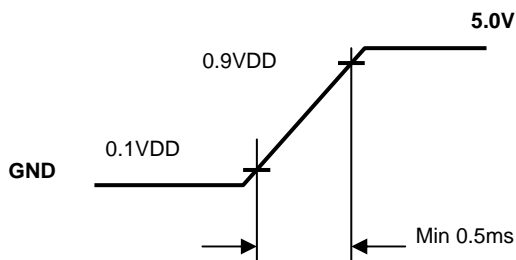

Document Title	HSD190ME12- A Product Information	Page No.	18 /29
Document No.		Revision	1.0

6.2 Back-Light Unit

The back-light system is an edge-lighting type with 4 CCFL(Cold Cathode Fluorescent Lamp). The characteristics of the lamp are shown in the following tables.

Item	Symbol	Min.	Typ.	Max.	Unit	Note
Lamp current	IL	3.5	6.5	9.0	mA(rms)	(1)
Lamp voltage	VL	630	700	770	V(rms)	$I_L=6.5\text{mA}$
Frequency	fL	40	48	80	KHz	(2)
Operating lamp life time	Hr	50000	--	--	Hour	6.5mA (3)
Startup voltage	Vs	1210	--	--	V(rms)	at 25°C
		1430		-		at 0°C

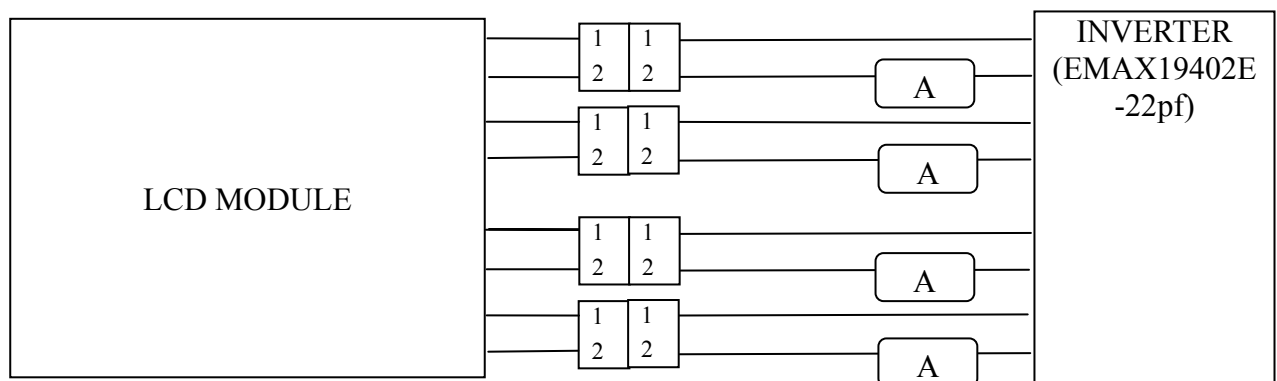

Note (1)

Lamp current is measured with current meter for high frequency as shown below. Specified values are for a single lamp. To exceed 6.5mA, life time accelerate drop down and if to exceed 9.0 mA has safety problem. If current lower than 3.5 mA, CCFL would be unstable or damaged.

Note (2)

Lamp frequency may produce interference with horizontal synchronous frequency and this may cause ripple noise on the display. Therefore lamp frequency shall be kept away from the horizontal synchronous frequency and its harmonics as far as possible in order to avoid interference.

Note (3)

Lamp life time (Hr) can be defined as the time in which it continues to operate under the condition : $T_a=25\pm 3^\circ\text{C}$, Typical IL value indicated in the above table and $f_L=48\text{ kHz}$ until the brightness becomes less than 50%

Document Title	HSD190ME12- A Product Information	Page No.	19 /29
Document No.		Revision	1.0

Note (4)

CCFL inverter should be able to provide a voltage over specified value (V_s) in the above table. Lamp units need at least V_s value shown above to ignition.

Note (5)

The voltage over specified value (V_s) should be applied to the lamp more than 1 second after startup. Otherwise, the lamp may not be turned on. The used lamp current is the lamp typical current.

Note (6)

The output voltage waveform and current waveform of the inverter must be symmetrical (Unsymmetrical ratio is less than 10%). Please do not use the inverter which has unsymmetrical voltage and current waveform, and spike waveform. The inverter design which can provide the best optical performance, power efficiency, and lamp life should under the following conditions.

- The asymmetry rate of the inverter waveform should be less than 10%.
- The distortion rate of the waveform should be within $2\pm 10\%$.
- The inverter output waveform should be better similar to the ideal sine wave.

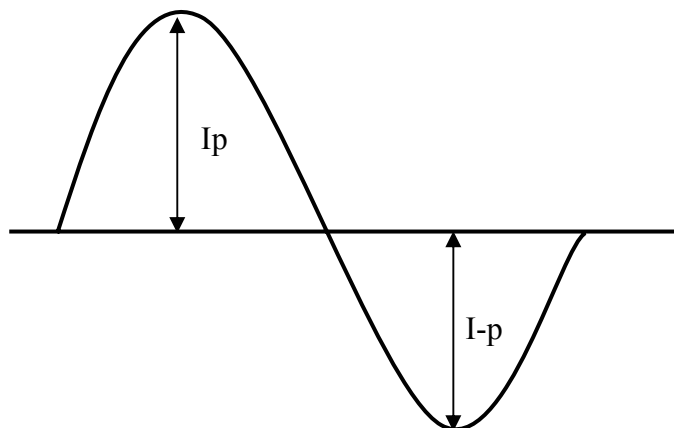

$$\text{Asymmetry rate} = |I_p - I-p| / I_{rms} \times 100\%$$

$$\text{Distortion rate} = I_p \text{ (or } I-p) / I_{rms}$$



Document Title	HSD190ME12- A Product Information	Page No.	20 /29
Document No.		Revision	1.0

6.3 Interface Timing (DE mode)

Item	Symbol	Min.	Typ.	Max.	Unit
Frame Rate	--	60	60	75	Hz
Frame Period	t1	1032	1066	1100	line
Vertical Display Time	t2	1024	1024	1024	line
Vertical Blanking Time	t3	8	42	--	line
1 Line Scanning Time	t4	780	844	880	clock
Horizontal Display Time	t5	640	640	640	clock
Horizontal Blanking Time	t6	140	204	--	clock
Clock Rate	t7	50	54	67.5	MHz

Timing Diagram of Interface Signal (DE mode)

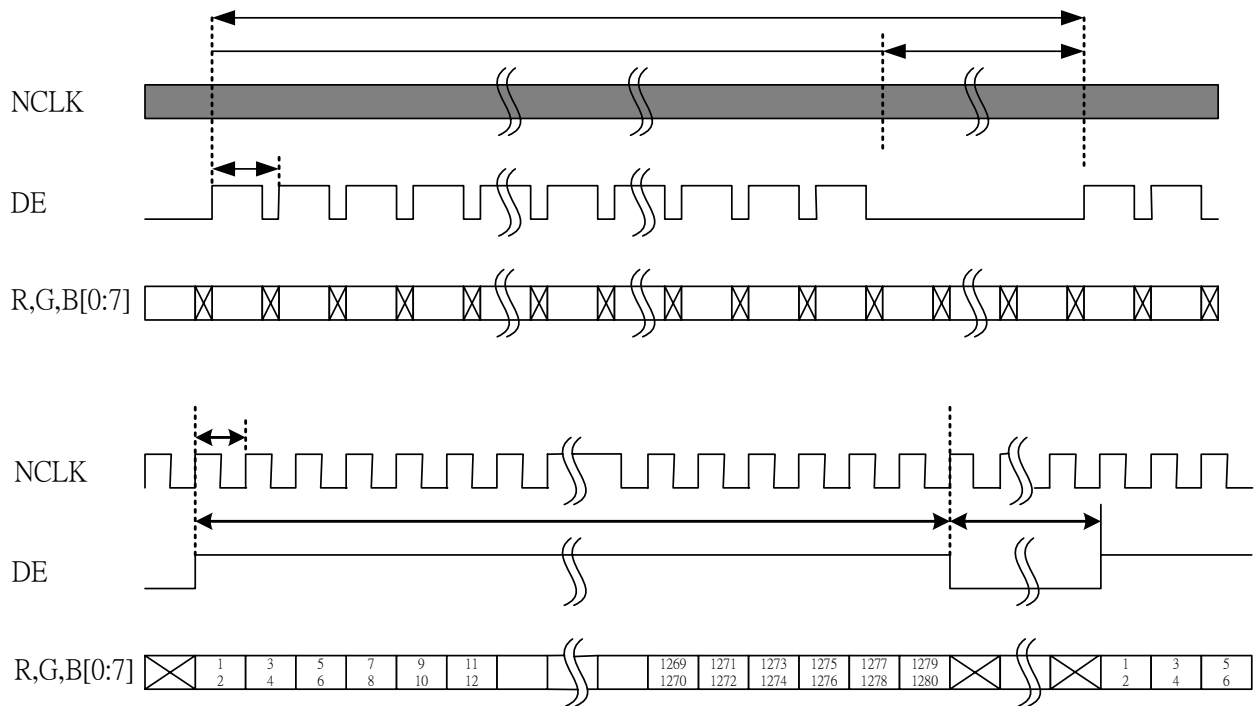

Document Title	HSD190ME12- A Product Information	Page No.	21 /29
Document No.		Revision	1.0

7.0 Input Timing Spec

7.1 Power On / Off Sequence :

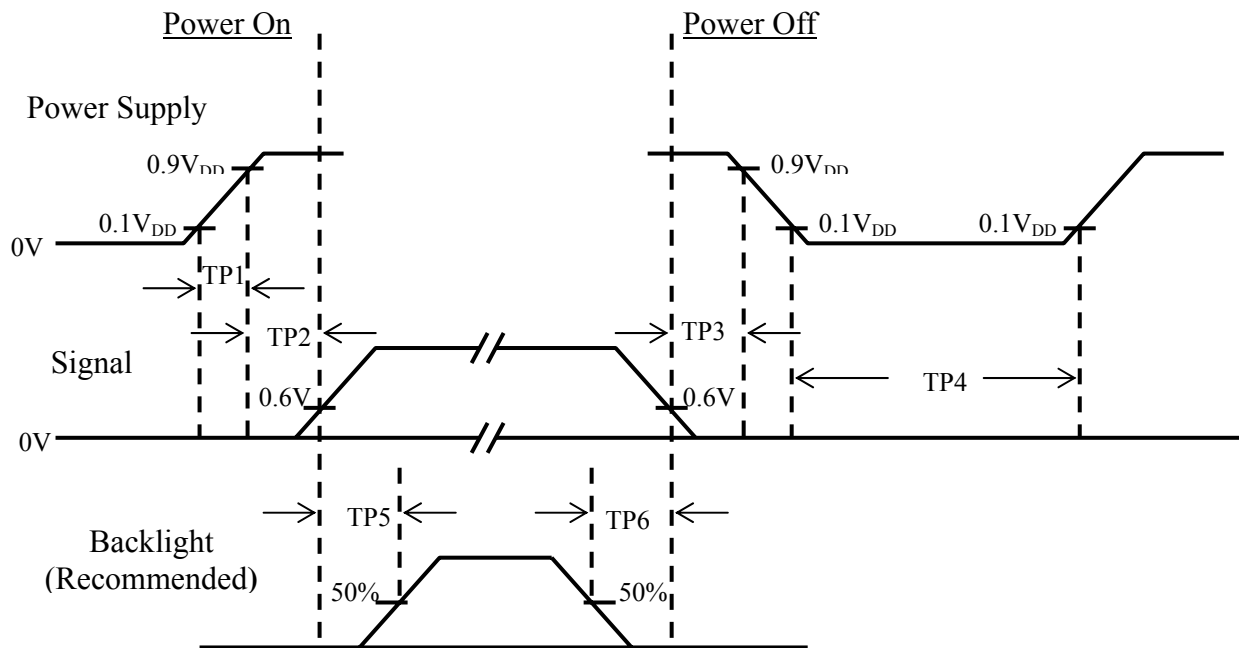

Item	Min.	Typ.	Max.	Unit	Remark
TP1	0.5	—	10	msec	
TP2	0	—	50	msec	
TP3	0	—	50	msec	
TP4	0.5	—	—	sec	
TP5	200	—	—	msec	
TP6	200	—	—	msec	

- Note : (1) The supply voltage of the external system for the module input should be the same as the definition of V_{DD}.
- (2) Apply the lamp voltage within the LCD operation range. When the back-light turns on before the LCD operation or the LCD turns off before the back-light turns off, the display may momentarily become white.
- (3) In case of V_{DD} = off level, please keep the level of input signal on the low or keep a high impedance.
- (4) T4 should be measured after the module has been fully discharged between power off and on period.
- (5) Interface signal shall not be kept at high impedance when the power is on.



Document Title	HSD190ME12- A Product Information	Page No.	22 /29
Document No.		Revision	1.0

8.0 OUTLINE DIMENSION

8.1 Front View:

Date: 2004.04.30

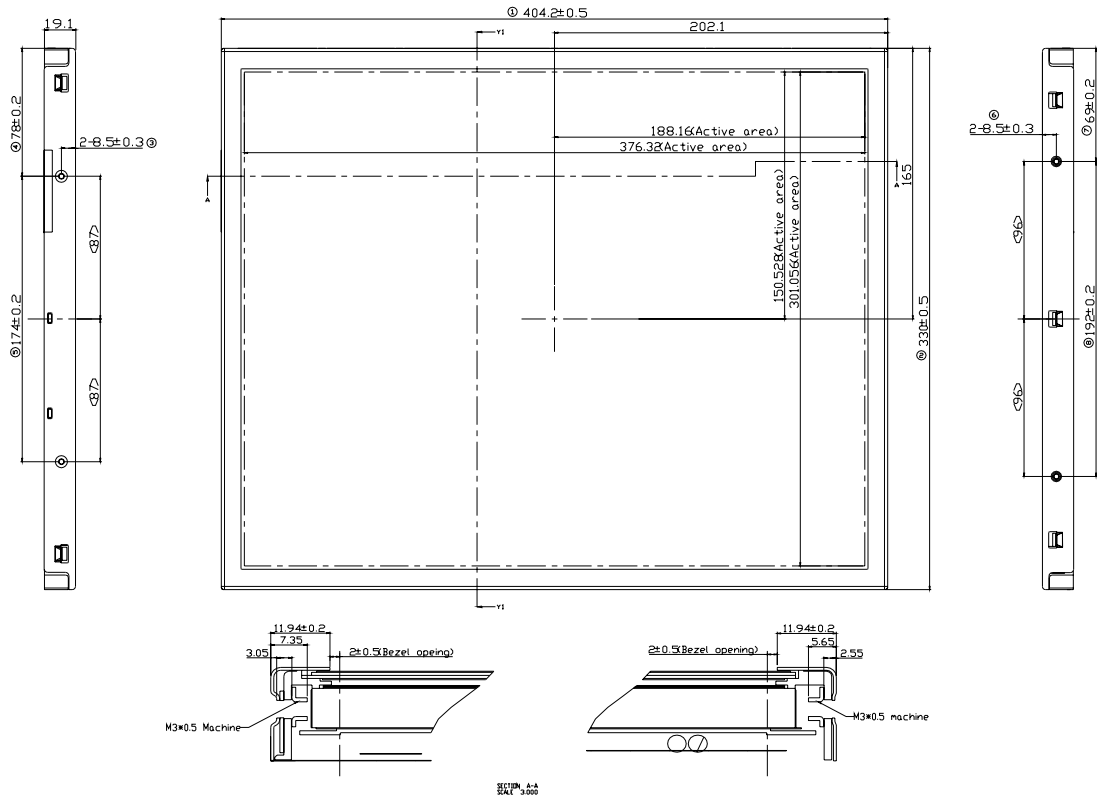

Note: BM : | A-B | & | C-D | < 1.0mm

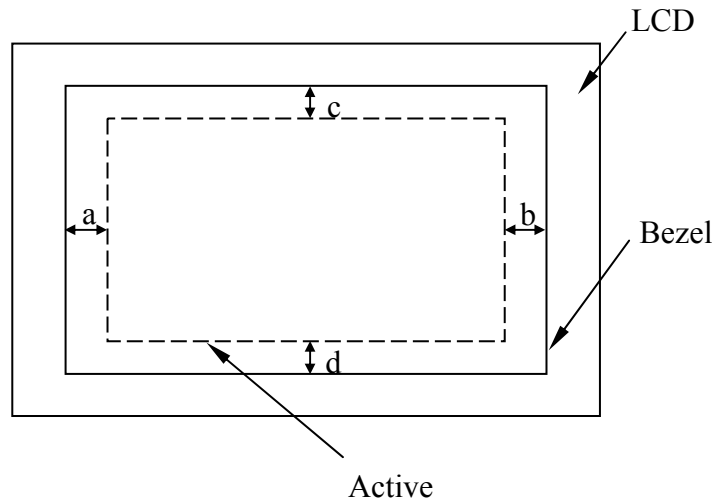

The information contained in this document is the exclusive property of HannStar Display Corporation. It shall not be disclosed, distributed or reproduced in whole or in part without written permission of HannStar Display Corporation.



HannStar Display Corp.

Document Title	HSD190ME12- A Product Information	Page No.	23 /29
Document No.		Revision	1.0

8.2 Back View :

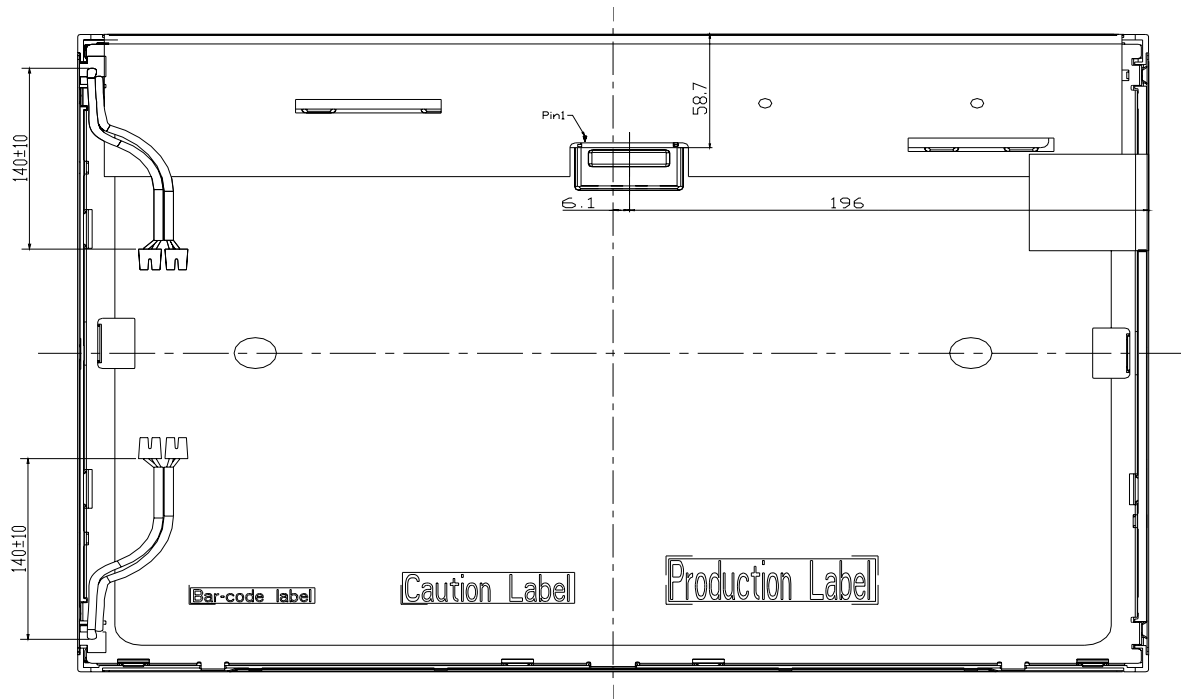

The information contained in this document is the exclusive property of HannStar Display Corporation. It shall not be disclosed, distributed or reproduced in whole or in part without written permission of HannStar Display Corporation.



Document Title	HSD190ME12- A Product Information	Page No.	24 /29
Document No.		Revision	1.0

9.0 LOT MARK

9.1 Lot Mark

1	2	3	4	5	6	7	8	9	10	11	12	13	14	15
---	---	---	---	---	---	---	---	---	----	----	----	----	----	----

code 1,2,3,4,5,6: HannStar internal flow control code.

code 7: production location.

code 8: production year.

code 9: production month.

code 10,11,12,13,14,15: serial number.

Note (1) Production Year

Year	1999	2000	2001	2002	2003	2004	2005	2006	2007	2008
Mark	9	0	1	2	3	4	5	6	7	8

Note (2) Production Month

Month	Jan.	Feb.	Mar.	Apr.	May.	Jun.	Jul.	Aug.	Sep.	Oct	Nov.	Dec.
Mark	1	2	3	4	5	6	7	8	9	A	B	C

9.2 Sub Model Code

1	2	3
---	---	---

code 1: Panel sub model code of type. (A~Z)

code 2,3: Panel product sub model code of serial number.

(00~99)



HannStar Display Corp.

Document Title	HSD190ME12- A Product Information	Page No.	25 /29
Document No.		Revision	1.0

9.3 Location of Lot Mark

- (1) The label is attached to the backside of the LCD module.
- (2) This is subject to change without prior notice.

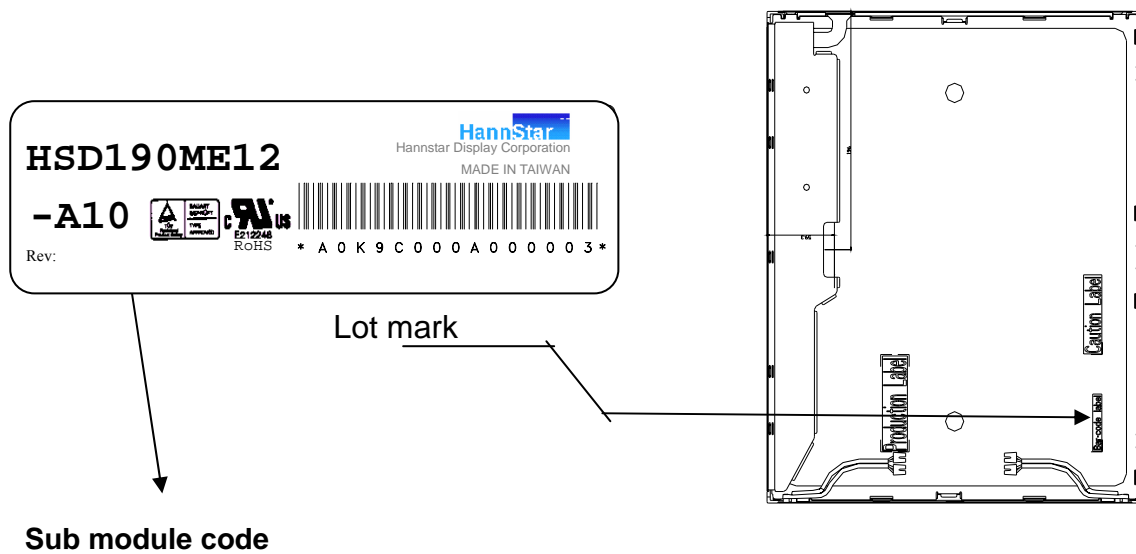



Document Title	HSD190ME12- A Product Information	Page No.	26 /29
Document No.		Revision	1.0

10.0 PACKAGE SPECIFICATION

10.1 packing form

- (1) package quantity in one carton: 8 pieces.
- (2) carton size: 544±3 mm×302±3 mm×446±3 mm.
- (3) for domestic transportation only.

10.2 packing assembly drawings

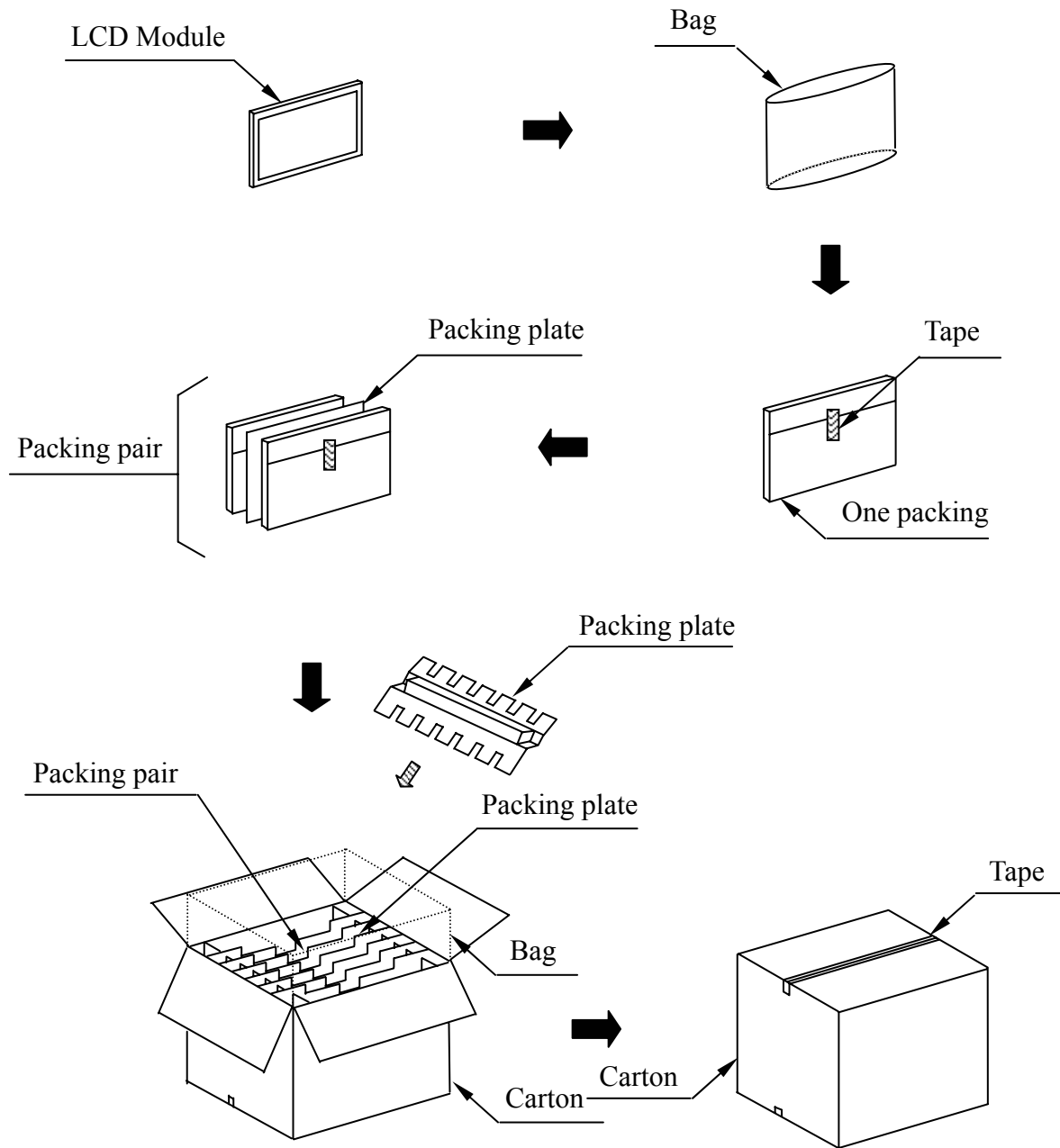



HannStar Display Corp.

Document Title	HSD190ME12- A Product Information	Page No.	27 /29
Document No.		Revision	1.0

10.3 Pallet transportation specification

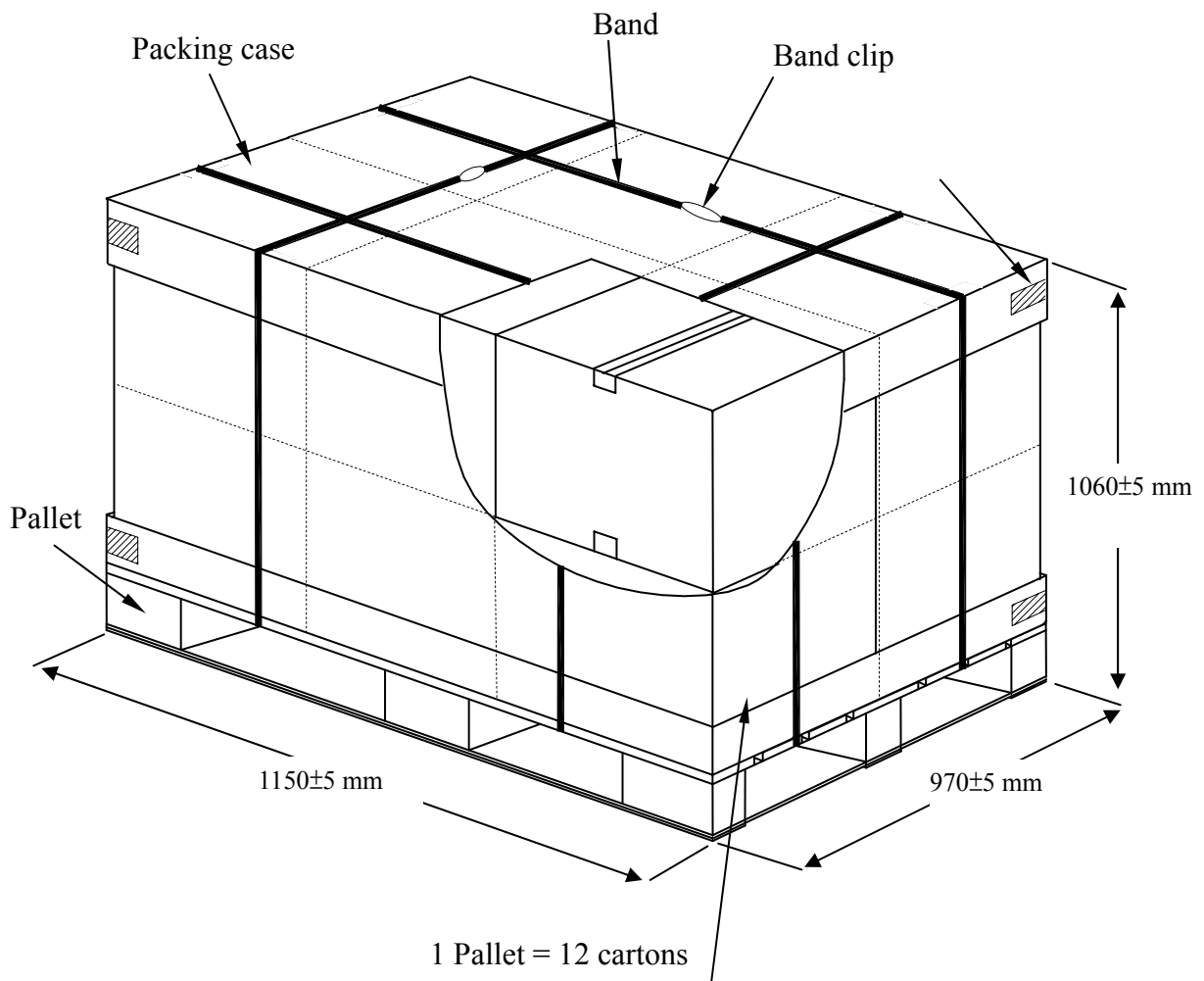

The information contained in this document is the exclusive property of HannStar Display Corporation. It shall not be disclosed, distributed or reproduced in whole or in part without written permission of HannStar Display Corporation.



Document Title	HSD190ME12- A Product Information	Page No.	28 /29
Document No.		Revision	1.0

11.0 GENERAL PRECAUTION

11.1 Use Restriction

This product is not authorized for use in life supporting systems, aircraft navigation control systems, military systems and any other application where performance failure could be life-threatening or otherwise catastrophic.

11.2 Disassembling or Modification

Do not disassemble or modify the module. It may damage sensitive parts inside LCD module, and may cause scratches or dust on the display. HannStar does not warrant the module, if customers disassemble or modify the module.

11.3 Breakage of LCD Panel

- 11.3.1 If LCD panel is broken and liquid crystal spills out, do not ingest or inhale liquid Crystal, and do not contact liquid crystal with skin.
- 11.3.2 If liquid crystal contacts mouth or eyes, rinse out with water immediately.
- 11.3.3 If liquid crystal contacts skin or cloths, wash it off immediately with alcohol and Rinse thoroughly with water.
- 11.3.4 Handle carefully with chips of glass that may cause injury, when the glass is Broken

11.4 Electric Shock

- 11.4.1 Disconnect power supply before handling LCD module.
- 11.4.2 Do not pull or fold the CCFL cable.
- 11.4.3 Do not touch the parts inside LCD modules and the fluorescent lamp's connector Or cables in order to prevent electric shock

11.5 Absolute Maximum Ratings and Power Protection Circuit

- 11.5.1 Do not exceed the absolute maximum rating values, such as the supply voltage variation, input voltage variation, variation in parts' parameters, environmental temperature; etc otherwise LCD module may be damaged.
- 11.5.2 Please do not leave LCD module in the environment of high humidity and high temperature for a long time.
- 11.5.3 It's recommended employing protection circuit for power supply.

11.6 Operation

- 11.6.1 Do not touch, push or rub the polarizer with anything harder than HB pencil lead. Use fingerstalls of soft gloves in order to keep clean display quality, when Persons handle the LCD module for incoming inspection or assembly.
- 11.6.2 When the surface is dusty, please wipe gently with absorbent cotton or other soft Material
- 11.6.3 Wipe off saliva or water drops as soon as possible. If saliva or water drops Contact with polarizer for a long time, they may causes deformation or color Fading
- 11.6.4 When cleaning the adhesives, please use absorbent cotton wetted with a little Petroleum benzene or other adequate solvent



Document Title	HSD190ME12- A Product Information	Page No.	29 /29
Document No.		Revision	1.0

11.7 Mechanism

Please mount LCD module by using mounting holes arranged in four corners tightly.

11.8 Static Electricity

11.8.1 Protection film must remove very slowly from the surface of LCD module to Prevent from electrostatic occurrence.

11.8.2 Because LCD module uses CMOS-IC on circuit board and TFT-LCD panel, it is Very weak to electrostatic discharge, Please be careful with electrostatic Discharge

11.8.3 Persons who handle the module should be grounded through adequate methods.

11.9 Strong Light Exposure

The module shall not be exposed under strong light such as direct sunlight. Otherwise, Display characteristics may be changed.

11.10 Disposal

When disposing LCD module, obey the local environmental regulations.