



HannStar Display Corp.

Document Title	<b>HSD190ME13- A02</b> Preliminary product information	Page No.	1 / 28
Document No.		Revision	1.0

## **Preliminary Product information**

**Model : HSD190ME13  
- A02**

- Note:
1. Please contact HannStar Display Corp. before designing your product based on this module specification.
  2. The information contained herein is presented merely to indicate the characteristics and performance of our products. No responsibility is assumed by HannStar for any intellectual property claims or other problems that may result from application based on the module described herein.



HannStar Display Corp.

Document Title	<b>HSD190ME13- A02</b> Preliminary product information	Page No.	2 / 28
Document No.		Revision	1.0

### Record of Revisions

Rev.	Updated No.	Date	Description of change
1.0		Jan.26,2005	Preliminary product information for HSD190ME13-A02 was first issued.



HannStar Display Corp.

Document Title	<b>HSD190ME13- A02</b> Preliminary product information	Page No.	3 / 28
Document No.		Revision	1.0

## Contents

1.0	General descriptions .....	p.4
2.0	Absolute maximum ratings .....	p.5
3.0	Optical characteristics .....	p.7
4.0	Block diagram .....	p.12
5.0	I/O Connection Pin assignment .....	p.15
6.0	Electrical Characteristics .....	p.16
7.0	Input Timing Spec.....	p.21
8.0	Outline dimension .....	p.22
9.0	Lot Mark .....	p.25
10.0	Package Specification .....	P.26
11.0	General precaution .....	p.27



Document Title	<b>HSD190ME13- A02</b> Preliminary product information	Page No.	4 / 28
Document No.		Revision	1.0

## 1.0 GENERAL DESCRIPTIONS

### 1.1 Introduction

HannStar Display model **HSD190ME13-A02** is a color active matrix thin film transistor (TFT) liquid crystal display (LCD) that uses amorphous silicon TFT as a switching device. This model is composed of a TFT LCD panel, the voltage reference, common voltage, DC-DC converter, column, and row driver circuit. This TFT LCD has a 19-inch diagonally measured active display area with SXGA resolution (1024 vertical by 1280 horizontal pixel array).

### 1.2 Features

- 19" SXGA TFT LCD panel
- 4 CCFLs Backlight system
- Supported SXGA (V:1024 lines, H:1280 pixels) resolution
- Supported to 75Hz refresh rate
- LCD Timing Controller

### 1.3 General information

Item	Specification		Unit
Outline dimension	396*324 *18.5(typ)		mm
Display area	376.32 (H) x301.056 (V) (19.0" diagonal)		mm
Number of Pixel	1280(H) x 1024(V)		Pixels
Pixel pitch	0.294(H) x 0.294(V)		mm
Pixel arrangement	RGB Vertical stripe		
Display color	16.2M (6-bits+FRC)		
Display mode	Normally white		
Surface treatment	Antiglare, Hard-Coating(3H)		
Weight	2300(typ.)		G
Back-light	4-CCFLs, Top & bottom edge side		
Input signal	2 -CH LVDS		
Power consumption	System	3.5	W
	B/L	18	
Optimum viewing direction	6 o' clock		

### 1.4 Applications

- Desktop monitors
- Display terminals for AV applications
- Monitors for industrial applications



Document Title	HSD190ME13- A02 Preliminary product information	Page No.	5 / 28
Document No.		Revision	1.0

### 1.5 Mechanical Information

Item		Min.	Typ.	Max.	Unit
Module Size	Horizontal(H)	395.5	396.0	396.5	mm
	Vertical(V)	323.5	324.0	324.5	mm
	Depth(D)	18.0	18.5	19.0	mm
Weight (without inverter)		2185	2300	2415	g
Torque of customer screw hole				3.0	Kgf*Cm

## 2.0 ABSOLUTE MAXIMUM RATINGS

### 2.1 Absolute Rating of Environment

Item	Symbol	Min.	Max.	Unit	Note
Storage temperature	T <sub>STG</sub>	-20	60	°C	
Operating temperature	T <sub>OPR</sub>	0	50	°C	(1)
Vibration(non-operating)	V <sub>NOP</sub>	--	1.5	G	(2)
Shock(non-operating)	S <sub>NOP</sub>	--	70	G	(3)
Storage humidity	H <sub>STG</sub>	10	90	%RH	(3)
Operating humidity	H <sub>OP</sub>	10	80	%RH	(4)
Low pressure(operating)	P <sub>LOP</sub>	697	--	HPa	(5)
Low pressure(non-operating)	P <sub>LNOP</sub>	116	--	HPa	(6)

Note (1)Storage /Operating temperature

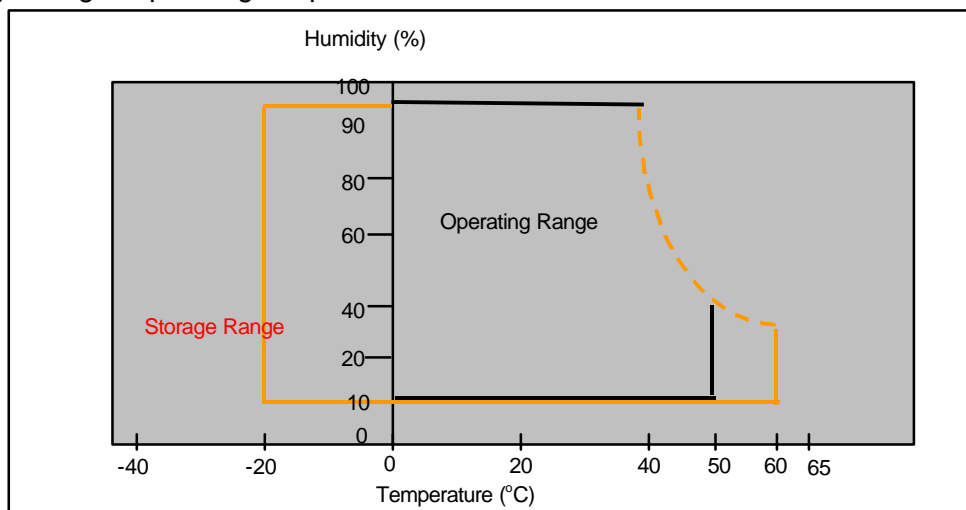



Document Title	<b>HSD190ME13- A02</b> Preliminary product information	Page No.	6 / 28
Document No.		Revision	1.0

- (2) **5-500-5**Hz sine wave, X,Y,Z each directions, 30 min/cycle.
- (3) 11ms,  $\pm X$ ,  $\pm Y$ ,  $\pm Z$  direction, one time each. For this shock test,  
It is necessary to fill the silicon rubber between the shock jig as buffer.
- (4) Max wet bulb temp.  $\approx 39^{\circ}\text{C}$
- (5) **2** hrs. (10000 feet)
- (6) 24hrs. (50000 feet)

## 2.2 Electrical Absolute Rating:

### 2.2.1 TFT LCD Module:

Item	Symbol	Min.	Max.	Unit.	Note
Power supply Voltage	$V_{DD}$	-0.3	5.5	V(DC)	(1)(2)

### 2.2.2 Back Light Unit:

Item	Symbol	Min.	Max.	Unit	Note
Lamp voltage	$V_L$	--	2000	V(rms)	(1)(2)(3)
Lamp current	$I_L$	3.5	9.0	mA	(1)(2)(3)
Lamp frequency	$f_L$	40	80	KHz	(1)(2)(3)

Note: (1) Permanent damage may occur to the LCD module if beyond this specification.

Functional operation should be restricted to the conditions described under Normal Operating Conditions.

- (2) To exceed 6.5mA, life time accelerate drop down and if to exceed 9.0 mA has safety problem. If current lower than 3.5 mA, CCFL would be unstable or damaged.

- (3) Within  $T_a = 25 \pm 2^{\circ}\text{C}$



Document Title	HSD190ME13- A02 Preliminary product information	Page No.	7 / 28
Document No.		Revision	1.0

### 3.0 OPTICAL CHARACTERISTICS

#### 3.1 Optical specification

Item	Symbol	Condition	Min.	Typ.	Max.	Unit	Note
Contrast	CR		450	600	--		(1)(2)
Response time	Rising	TR +TF	--	8	--	msec	(1)(3)
	Falling						
White luminance (center of screen)	$Y_L$	$\phi=0^\circ$	--	250	--	cd/m <sup>2</sup>	(1)(4) (IL=6.5mA)
Color chromaticity (CIE1931)	Red	Rx	Normal viewing angle	0.617	0.647	0.677	(1)(4)
		Ry		0.297	0.327	0.357	
	Green	Gx		0.262	0.292	0.322	
		Gy		0.584	0.614	0.644	
	Blue	Bx		0.112	0.142	0.172	
		By		0.049	0.079	0.109	
	White	Wx		0.280	0.310	0.340	
		Wy		0.300	0.330	0.360	
Viewing angle	Hor.	L	CR>10	--	70	--	
		R		--	70	--	
	Ver.	H		--	65	--	
		L		--	65	--	
Brightness uniformity	$B_{UNI}$	$\phi=0^\circ$	--	80	--	%	(6)
Crosstalk	CT(n)	$\phi=0^\circ$	--	--	1.3	%	(7)

#### 3.2 Measuring Condition

Measuring surrounding : dark room

Lamp current  $I_{BL}$  : (6.5)±0.1mA, lamp freq.  $F_L=48$  KHz, Inverter :EMAX19402E(22pf)

$V_{DD1}=5.0V$ ,  $f_V=60Hz$ ,  $f_{DCLK}=54MHz$

Surrounding temperature : 25±2°C

30min. Warm-up time.

Document Title	<b>HSD190ME13- A02</b> Preliminary product information	Page No.	8 / 28
Document No.		Revision	1.0

### 3.3 Measuring Equipment

LCD-7000 of Otsuka Electric Corp., which utilized MCPD-7000 for Chromaticity and BM-5A for other optical characteristics.

Measuring spot size : 10~12mm

Note (1) Definition of Viewing Angle:

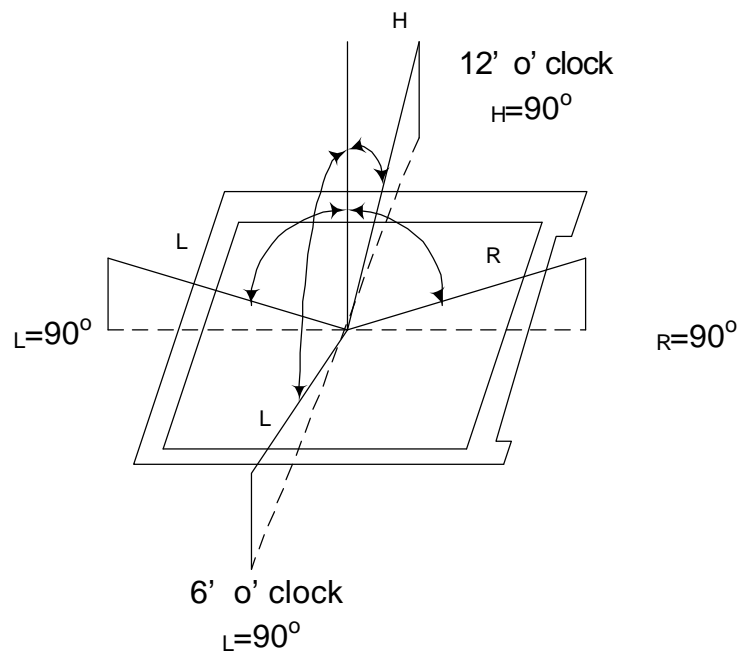

Note (2) Definition of Contrast Ratio(CR) :  
measured at the center point of panel

$$CR = \frac{\text{Luminance with all pixels white (L255)}}{\text{Luminance with all pixels black (L0)}}$$





Document Title	HSD190ME13- A02 Preliminary product information	Page No.	9 / 28
Document No.		Revision	1.0

Note (3) Definition of Response Time: Sum of  $T_R$  and  $T_F$

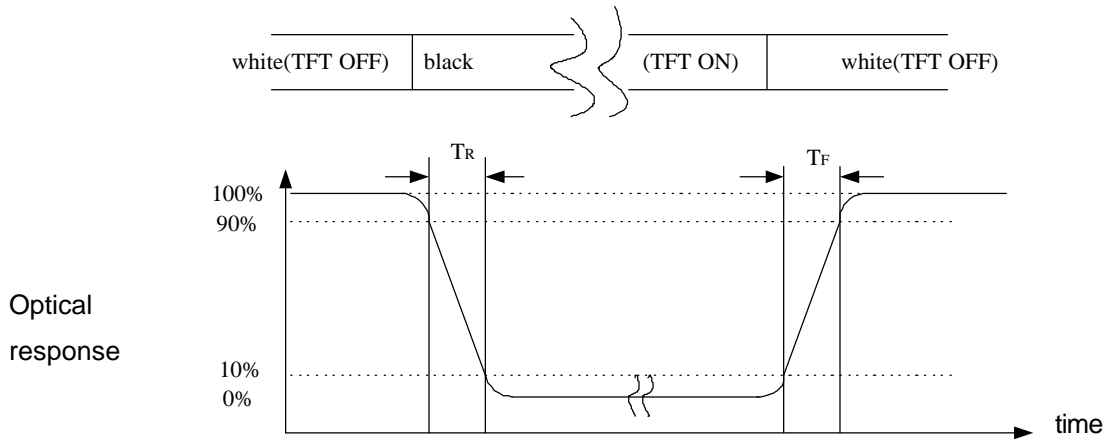

Note (4) Optical characteristic measurement setup

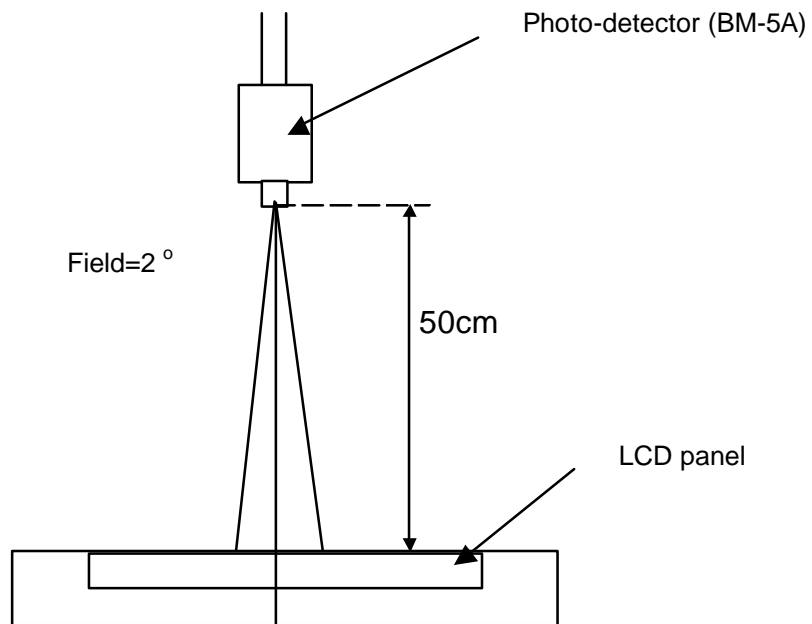



Document Title	HSD190ME13- A02 Preliminary product information	Page No.	10 / 28
Document No.		Revision	1.0

Note (5) Definition of Center Luminance of White

Center Luminance= Y1

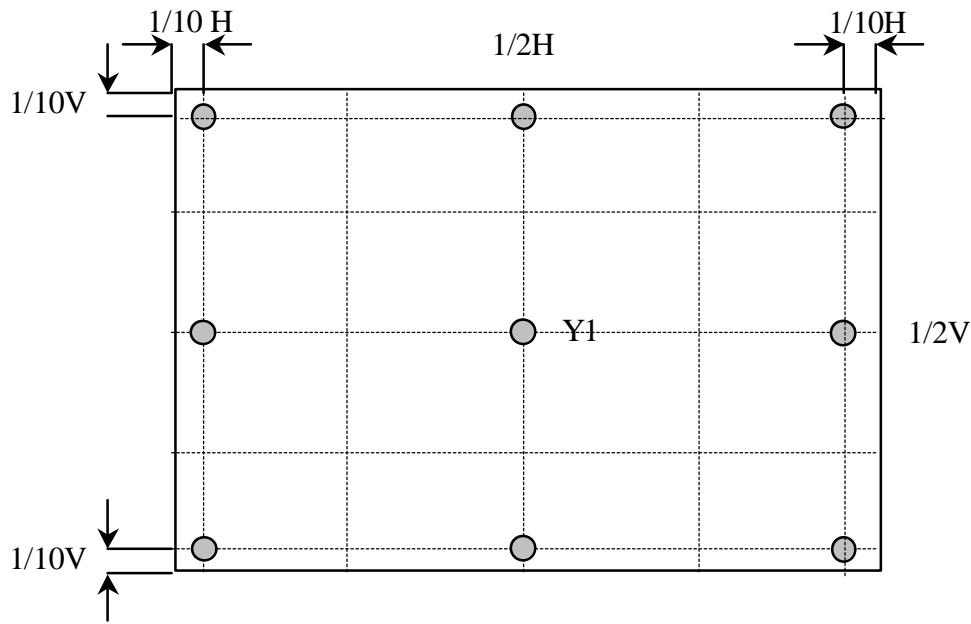

Note (6) Definition of brightness uniformity

$$\text{Luminance uniformity} = \frac{(\text{Min Luminance of 9 points})}{(\text{Max Luminance of 9 points})} \times 100\%$$



Document Title	HSD190ME13- A02 Preliminary product information	Page No.	11 / 28
Document No.		Revision	1.0

Note (7) Definition of crosstalk CT (1) ~ CT (4)

$$CT(n) = \frac{|L(n) - LB(n)|}{L(n)} \times 100\%, n = 1 \sim 4$$

Where L(n) = Luminance of point "n" at pattern A (cd/m<sup>2</sup>), n=1 ~ 4

LB(n) = Luminance of point "n" at pattern B (cd/m<sup>2</sup>), n=1 ~ 4

The location measured will be exactly the same in both patterns.

L0: Luminance with all pixels black

L255: Luminance with all pixels white

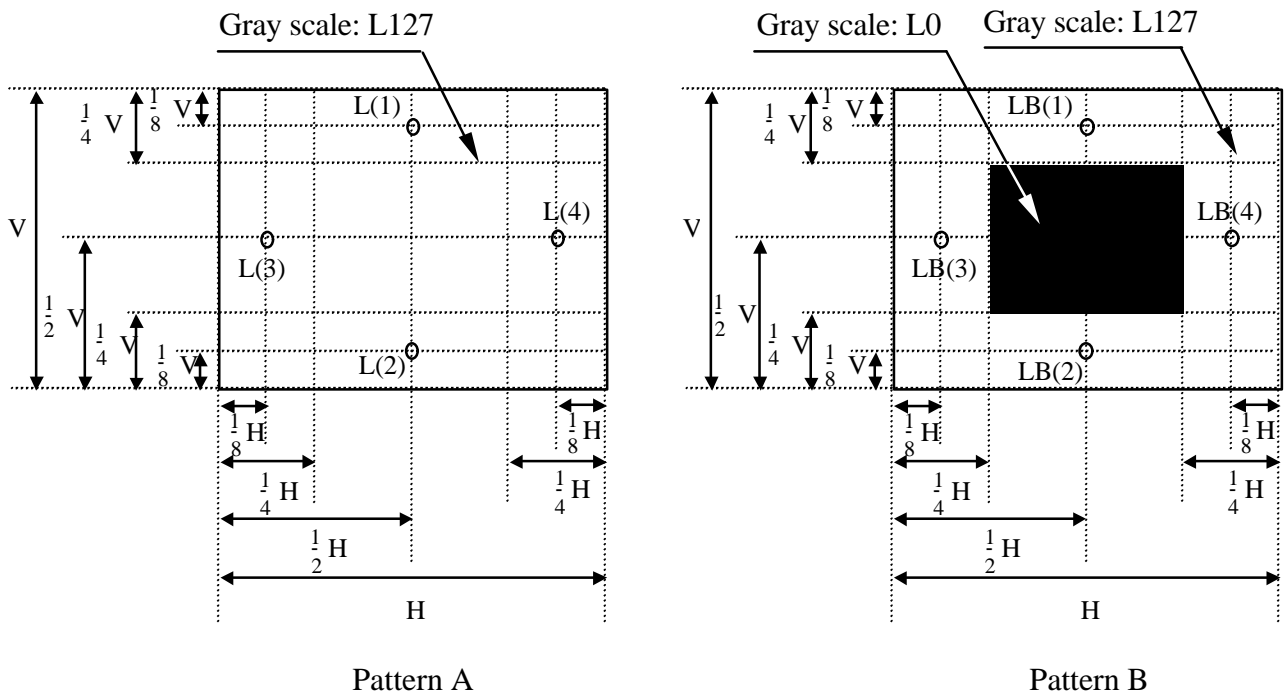



Document Title	HSD190ME13- A02 Preliminary product information	Page No.	12 / 28
Document No.		Revision	1.0

#### 4.0 BLOCK DIAGRAM

##### 4.1 LCD Module Block Diagram:

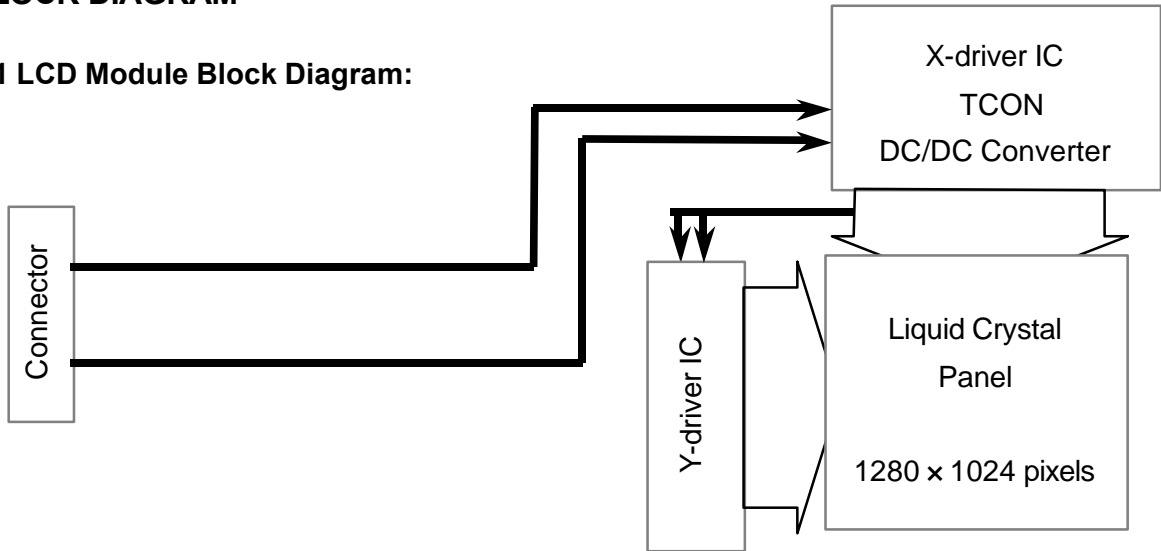



HannStar Display Corp.

Document Title	<b>HSD190ME13- A02</b> Preliminary product information	Page No.	13 / 28
Document No.		Revision	1.0

### 4.2 Back Light Unit

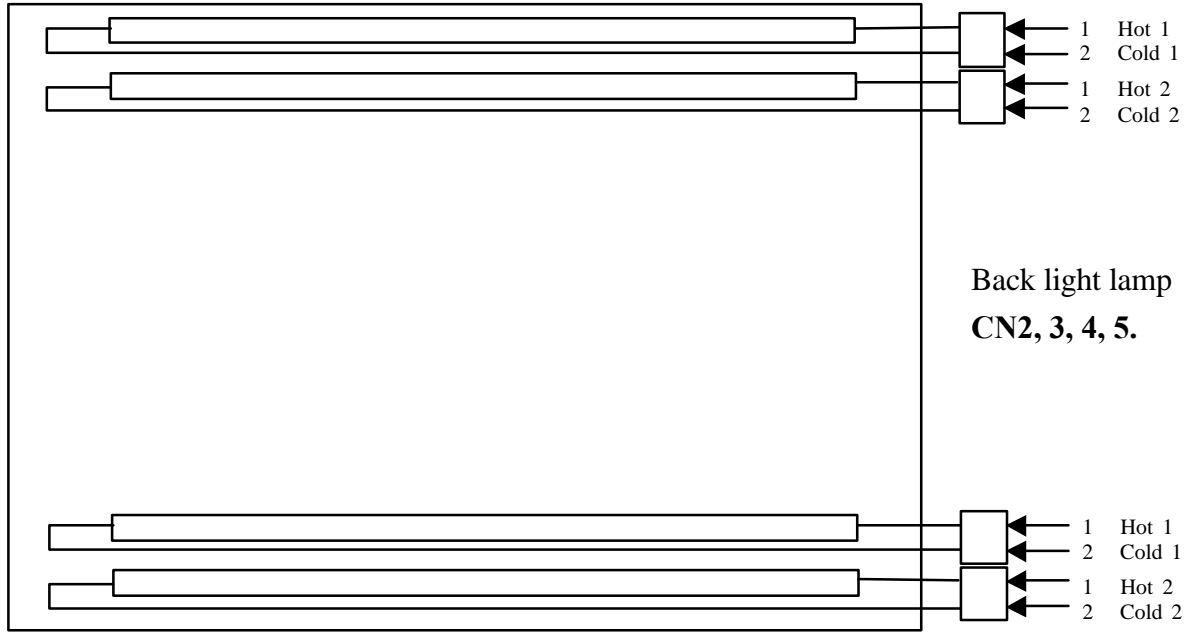

### 4.3 Pixel Format

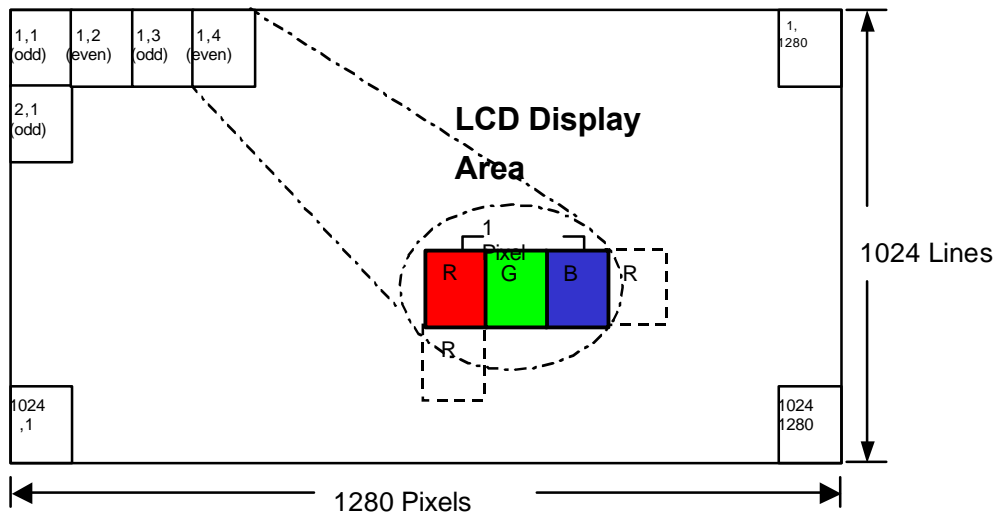



Document Title	HSD190ME13- A02 Preliminary product information	Page No.	14 / 28
Document No.		Revision	1.0

#### 4.4 Relationship Between Displayed Color and Input

Display	MSB				LSB				MSB				LSB				MSB				LSB				Gray scale Level	
	R7	R6	R5	R4	R3	R2	R1	R0	G7	G6	G5	G4	G3	G2	G1	G0	B7	B6	B5	B4	B3	B2	B1	B0		
Basic color	Black	L	L	L	L	L	L	L	L	L	L	L	L	L	L	L	L	L	L	L	L	L	L	L	L	-
	Blue	L	L	L	L	L	L	L	L	L	L	L	L	L	L	L	L	H	H	H	H	H	H	H	H	-
	Green	L	L	L	L	L	L	L	L	H	H	H	H	H	H	H	H	L	L	L	L	L	L	L	L	-
	Light Blue	L	L	L	L	L	L	L	L	H	H	H	H	H	H	H	H	H	H	H	H	H	H	H	H	-
	Red	H	H	H	H	H	H	H	H	L	L	L	L	L	L	L	L	L	L	L	L	L	L	L	L	-
	Purple	H	H	H	H	H	H	H	H	L	L	L	L	L	L	L	L	H	H	H	H	H	H	H	H	-
	Yellow	H	H	H	H	H	H	H	H	H	H	H	H	H	H	H	H	L	L	L	L	L	L	L	L	-
	White	H	H	H	H	H	H	H	H	H	H	H	H	H	H	H	H	H	H	H	H	H	H	H	H	-
Gray scale of Red	Black	L	L	L	L	L	L	L	L	L	L	L	L	L	L	L	L	L	L	L	L	L	L	L	L	L0
	Dark	L	L	L	L	L	L	L	H	L	L	L	L	L	L	L	L	L	L	L	L	L	L	L	L	L1
		L	L	L	L	L	L	H	L	L	L	L	L	L	L	L	L	L	L	L	L	L	L	L	L	L2
		:	:	:	:	:	:	:	:	:	:	:	:	:	:	:	:	:	:	:	:	:	:	:	:	L3 L251
	Light	H	H	H	H	H	L	H	H	L	L	L	L	L	L	L	L	L	L	L	L	L	L	L	L	L255
		H	H	H	H	H	H	L	H	L	L	L	L	L	L	L	L	L	L	L	L	L	L	L	L	L255
		H	H	H	H	H	H	H	L	L	L	L	L	L	L	L	L	L	L	L	L	L	L	L	L	L255
	Red	H	H	H	H	H	H	H	H	L	L	L	L	L	L	L	L	L	L	L	L	L	L	L	L	Red L255
Gray scale of Green	Black	L	L	L	L	L	L	L	L	L	L	L	L	L	L	L	L	L	L	L	L	L	L	L	L	L0
	Dark	L	L	L	L	L	L	L	L	L	L	L	L	L	L	L	H	L	L	L	L	L	L	L	L	L1
		L	L	L	L	L	L	L	L	L	L	L	L	L	L	H	L	L	L	L	L	L	L	L	L	L2
		:	:	:	:	:	:	:	:	:	:	:	:	:	:	:	:	:	:	:	:	:	:	:	:	L3 L251
	Light	L	L	L	L	L	L	L	L	H	H	H	H	H	L	H	H	L	L	L	L	L	L	L	L	L255
		L	L	L	L	L	L	L	L	H	H	H	H	H	L	H	L	L	L	L	L	L	L	L	L255	
		L	L	L	L	L	L	L	L	H	H	H	H	H	H	L	L	L	L	L	L	L	L	L	L255	
	Green	L	L	L	L	L	L	L	L	H	H	H	H	H	H	H	H	L	L	L	L	L	L	L	L	Green L255
Gray scale of Blue	Black	L	L	L	L	L	L	L	L	L	L	L	L	L	L	L	L	L	L	L	L	L	L	L	L	L0
	Dark	L	L	L	L	L	L	L	L	L	L	L	L	L	L	L	L	L	L	L	L	L	L	L	H	L1
		L	L	L	L	L	L	L	L	L	L	L	L	L	L	L	L	L	L	L	L	L	L	H	L	L2
		:	:	:	:	:	:	:	:	:	:	:	:	:	:	:	:	:	:	:	:	:	:	:	:	L3 L251
	Light	L	L	L	L	L	L	L	L	L	L	L	L	L	L	L	L	H	H	H	H	H	L	H	H	L255
		L	L	L	L	L	L	L	L	L	L	L	L	L	L	L	L	H	H	H	H	H	L	H	L255	
		L	L	L	L	L	L	L	L	L	L	L	L	L	L	L	L	H	H	H	H	H	H	L	L255	
	Blue	L	L	L	L	L	L	L	L	L	L	L	L	L	L	L	L	H	H	H	H	H	H	H	H	Blue L255
Gray scale of White & Black	Black	L	L	L	L	L	L	L	L	L	L	L	L	L	L	L	L	L	L	L	L	L	L	L	L	L0
	Dark	L	L	L	L	L	L	L	H	L	L	L	L	L	L	H	L	L	L	L	L	L	L	H	L1	
		L	L	L	L	L	L	H	L	L	L	L	L	L	H	L	L	L	L	L	L	L	H	L	L2	
		:	:	:	:	:	:	:	:	:	:	:	:	:	:	:	:	:	:	:	:	:	:	:	L3 L251	
	Light	H	H	H	H	H	L	H	H	H	H	H	H	L	H	H	H	H	H	H	L	H	H	H	L255	
		H	H	H	H	H	H	L	H	H	H	H	H	H	L	H	H	H	H	H	H	L	H	H	L255	
		H	H	H	H	H	H	H	L	H	H	H	H	H	H	L	H	H	H	H	H	H	L	H	L255	
	White	H	H	H	H	H	H	H	H	H	H	H	H	H	H	H	H	H	H	H	H	H	H	H	H	White L255



Document Title	<b>HSD190ME13- A02</b> Preliminary product information	Page No.	15 / 28
Document No.		Revision	1.0

## 5.0 I/O CONNECTION PIN ASSIGNMENT

### 5.1 Interface Connector (30-pins) (Jae: FI-X30SSL-HF)

Pin No.	Signal	Description
1	RinO0-	Receiver Signal (-)
2	RinO0+	Receiver Signal (+)
3	RinO1-	Receiver Signal (-)
4	RinO1+	Receiver Signal (+)
5	RinO2-	Receiver Signal (-)
6	RinO2+	Receiver Signal (+)
7	VSS	Ground
8	RinOC-	Clock Signal (-)
9	RinOC+	Clock Signal (+)
10	RinO3-	Receiver Signal (-)
11	RinO3+	Receiver Signal (+)
12	RinE0-	Receiver Signal (-)
13	RinE0+	Receiver Signal (+)
14	VSS	Receiver Signal (+)
15	RinE1-	Receiver Signal (-)
16	RinE1+	Receiver Signal (+)
17	VSS	Ground
18	RinE2-	Receiver Signal (-)
19	RinE2+	Receiver Signal (+)
20	RinEC-	Clock Signal (-)
21	RinEC+	Clock Signal (+)
22	RinE3-	Receiver Signal (-)
23	RinE3+	Receiver Signal (+)
24	VSS	Ground
25	VSS	Ground
26	NC	NC
27	VSS	Ground
28	VDD+5V	Power Supply, 5V (Typical)
29	VDD+5V	Power Supply, 5V (Typical)
30	VDD+5V	Power Supply, 5V (Typical)

### 5.2

#### Back Light Unit (CCFL) Connectors:

##### CN2, 3, 4, 5: CCFL Power Source (BHR-02VS-1)

Pin No.	Symbol	Color	Function
1	Hot1	Pink	CCFL power supply (High voltage)
2	Cold1	White	Ground

Document Title	<b>HSD190ME13- A02</b> Preliminary product information	Page No.	16 / 28
Document No.		Revision	1.0

## 6.0 ELECTRICAL CHARACTERISTICS

### 6.1 TFT LCD Module:

Item	Symbol	Min.	Typ.	Max.	Unit	Note	
Voltage of power supply	$V_{DD}$	4.5	5.0	5.5	V		
Current of power supply	V-Color	$I_{DD1}$	365	465	565	mA	(1)
	Mosaic	$I_{DD2}$	425	525	625	mA	(1)
Vsync frequency	$f_V$	56.25	60	75	Hz	(2)	
Hsync frequency	$f_H$	--	63.19	--	KHz		
Frequency	$f_{DCLK}$	50	54	67.5	MHz		
Input rush current	$I_{RUSH}$	--	---	3.0	A	(3)	

Note (1)

1).V-Color :





Document Title	<b>HSD190ME13- A02</b> Preliminary product information	Page No.	17 / 28
Document No.		Revision	1.0

2)Mosaic : 2 Dot checker image

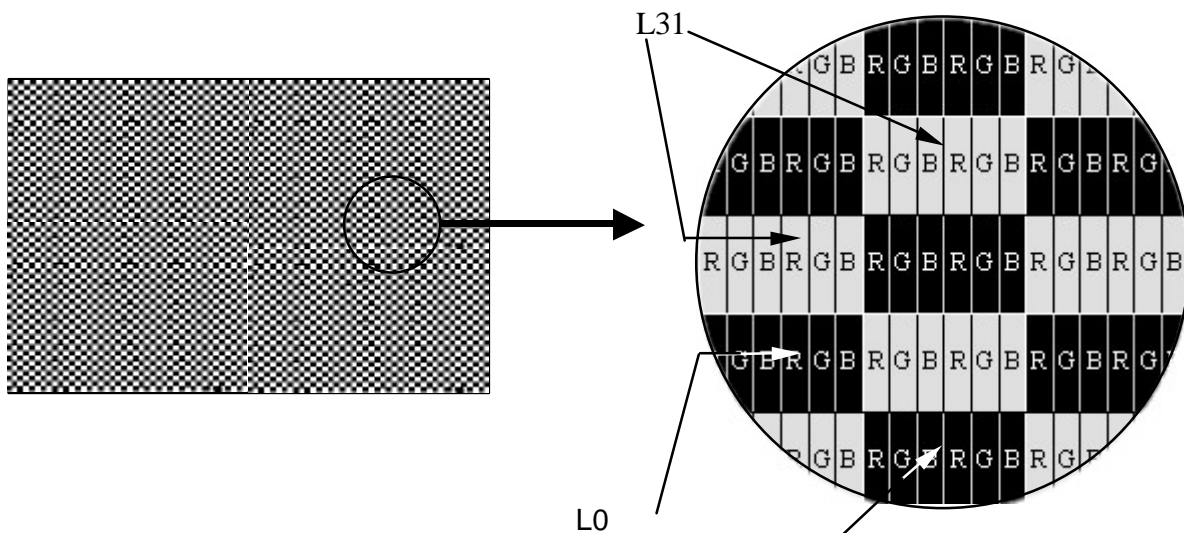

Grey scale:L0~L255

L0: Luminance with all pixels black.

L255: Luminance with all pixels white.

Note (2) When  $f_v$  is too low, a flicker may be occurred on the display.

Note (3) Input Rush Current condition

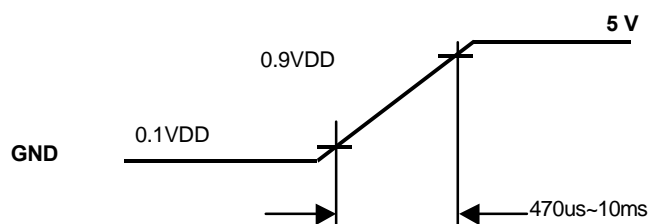

Document Title	<b>HSD190ME13- A02</b> Preliminary product information	Page No.	18 / 28
Document No.		Revision	1.0

## 6.2 Back-Light Unit

The back-light system is an edge-lighting type with 4 CCFL(Cold Cathode Fluorescent Lamp).  
The characteristics of the lamp are shown in the following tables.

Item	Symbol	Min.	Typ.	Max.	Unit	Note
Lamp current	IL	3.5	6.5	9.0	mA(rms)	(1)
Lamp voltage	VL	630	700	770	V(rms)	$I_L=6.5\text{mA}$
Frequency	fL	40	48	80	KHz	(2)
Live time	Hr	--	50000	--	Hour	6.5mA(3)
Startup voltage	Vs	1210	--	--	V(rms)	at 25°C
		1430				at 0°C

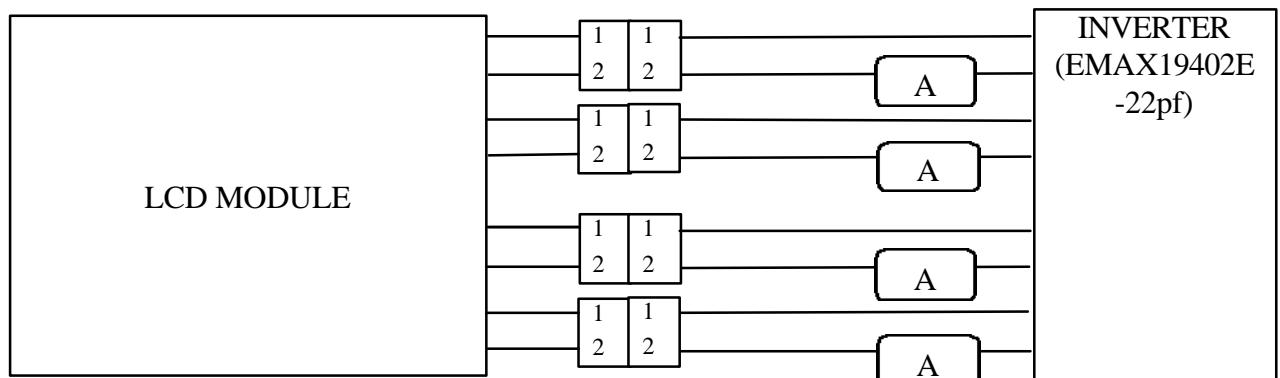

### Note (1)

Lamp current is measured with current meter for high frequency as shown below. Specified values are for a single lamp. To exceed 6.5.0mA, life time accelerate drop down and if to exceed 9.0 mA has safety problem. If current lower than 3.5 mA, CCFL would be unstable or damaged.

### Note (2)

Lamp frequency may produce interference with horizontal synchronous frequency and this may cause ripple noise on the display. Therefore lamp frequency shall be kept away from the horizontal synchronous frequency and its harmonics as far as possible in order to avoid interference.

### Note (3)

Lamp life time (Hr) can be defined as the time in which it continues to operate under the condition :  $T_a=25\pm 3^\circ\text{C}$ , Typical IL value indicated in the above table and  $f_L=48\text{ kHz}$  until the brightness becomes less than 50%

Document Title	<b>HSD190ME13- A02</b> Preliminary product information	Page No.	19 / 28
Document No.		Revision	1.0

**Note (4)**

CCFL inverter should be able to provide a voltage over specified value (Vs) in the above table. Lamp units need at least Vs value shown above to ignition.

**Note (5)**

The voltage over specified value (Vs) should be applied to the lamp more than 1 second after startup. Otherwise, the lamp may not be turned on. The used lamp current is the lamp typical current.

**Note (6)**

The output voltage waveform and current waveform of the inverter must be symmetrical (Unsymmetrical ratio is less than 10%). Please do not use the inverter which has unsymmetrical voltage and current waveform, and spike waveform. The inverter design which can provide the best optical performance, power efficiency, and lamp life should under the following conditions.

- The asymmetry rate of the inverter waveform should be less than 10%.
- The distortion rate of the waveform should be within  $\pm 10\%$ .
- The inverter output waveform should be better similar to the ideal sine wave.

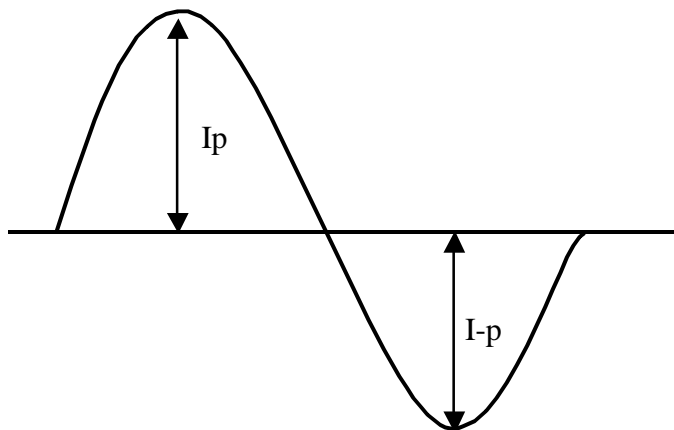

$$\text{Asymmetry rate} = |I_p - I_{-p}| / I_{rms} \times 100\%$$

$$\text{Distortion rate} = I_p \text{ (or } I_{-p}) / I_{rms}$$



Document Title	HSD190ME13- A02 Preliminary product information	Page No.	20 / 28
Document No.		Revision	1.0

### 6.3 Interface Timing ( DE mode) 1)2)3)4)5)6)

Item	Symbol	Min.	Typ.	Max.	Unit
Frame Period	t1	1028	1066	1150	line
Vertical Display Time	t2	1024	1024	1024	line
Vertical Blanking Time	t3	4			line
1 Line Scanning Time	t4	720	844	875	clock
Horizontal Display Time	t5	640	640		clock
Horizontal Blanking Time	t6	80			clock
Clock Period	t7	14.8	18.52	19.62	ns

#### Timing Diagram of Interface Signal (DE mode)

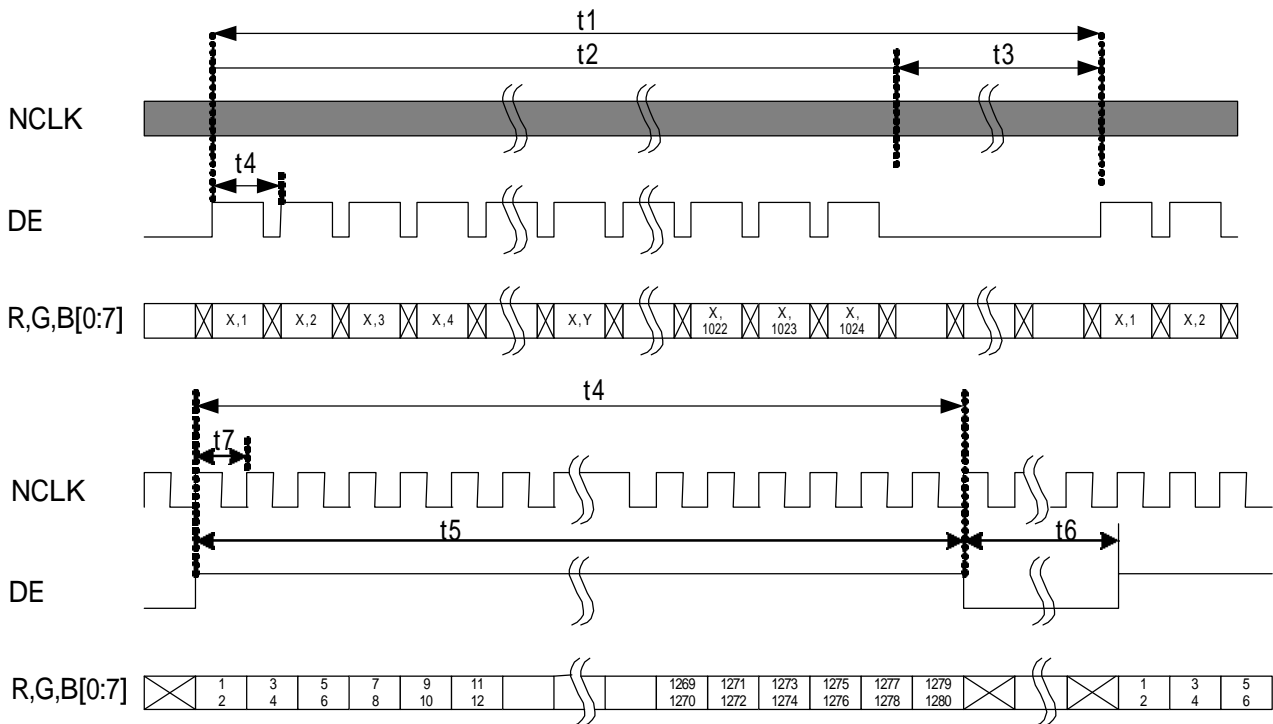

Document Title	HSD190ME13- A02 Preliminary product information	Page No.	21 / 28
Document No.		Revision	1.0

### 7.1 Power On / Off Sequence :

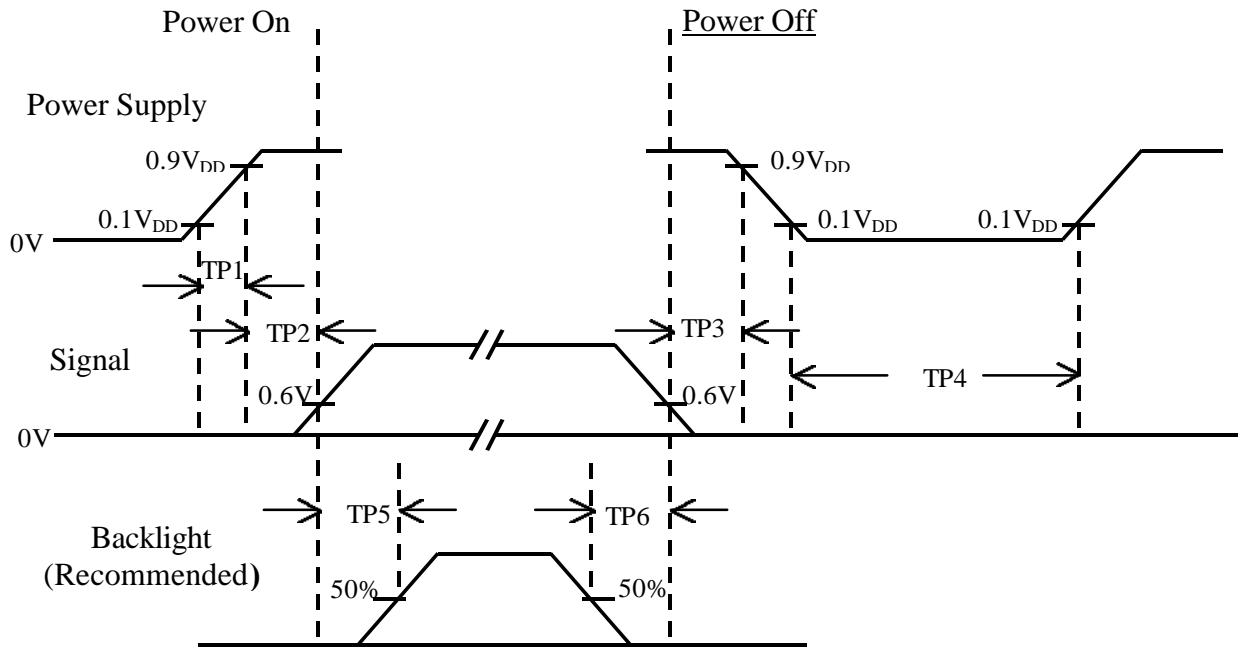

Item	Min.	Typ.	Max.	Unit	Remark
TP1	0.4	-	10	msec	
TP2	50	-	--	msec	
TP3	0	-	50	msec	
TP4	1	-	-	sec	
TP5	200	-	-	msec	

- Note :
- (1) The supply voltage of the external system for the module input should be the same as the definition of  $V_{DD}$ .
  - (2) Apply the lamp voltage within the LCD operation range. When the back-light turns on before the LCD operation or the LCD turns off before the back-light turns off, the display may momentarily become white.
  - (3) In case of  $V_{DD}$  = off level, please keep the level of input signal on the low or keep a high impedance.
  - (4) T4 should be measured after the module has been fully discharged between power off and on period.
  - (5) Interface signal shall not be kept at high impedance when the power is on.



Document Title	HSD190ME13- A02 Preliminary product information	Page No.	22 / 28
Document No.		Revision	1.0

### 8.0 OUTLINE DIMENSION

#### 8.1 Front View:

Date: 2004.12.23

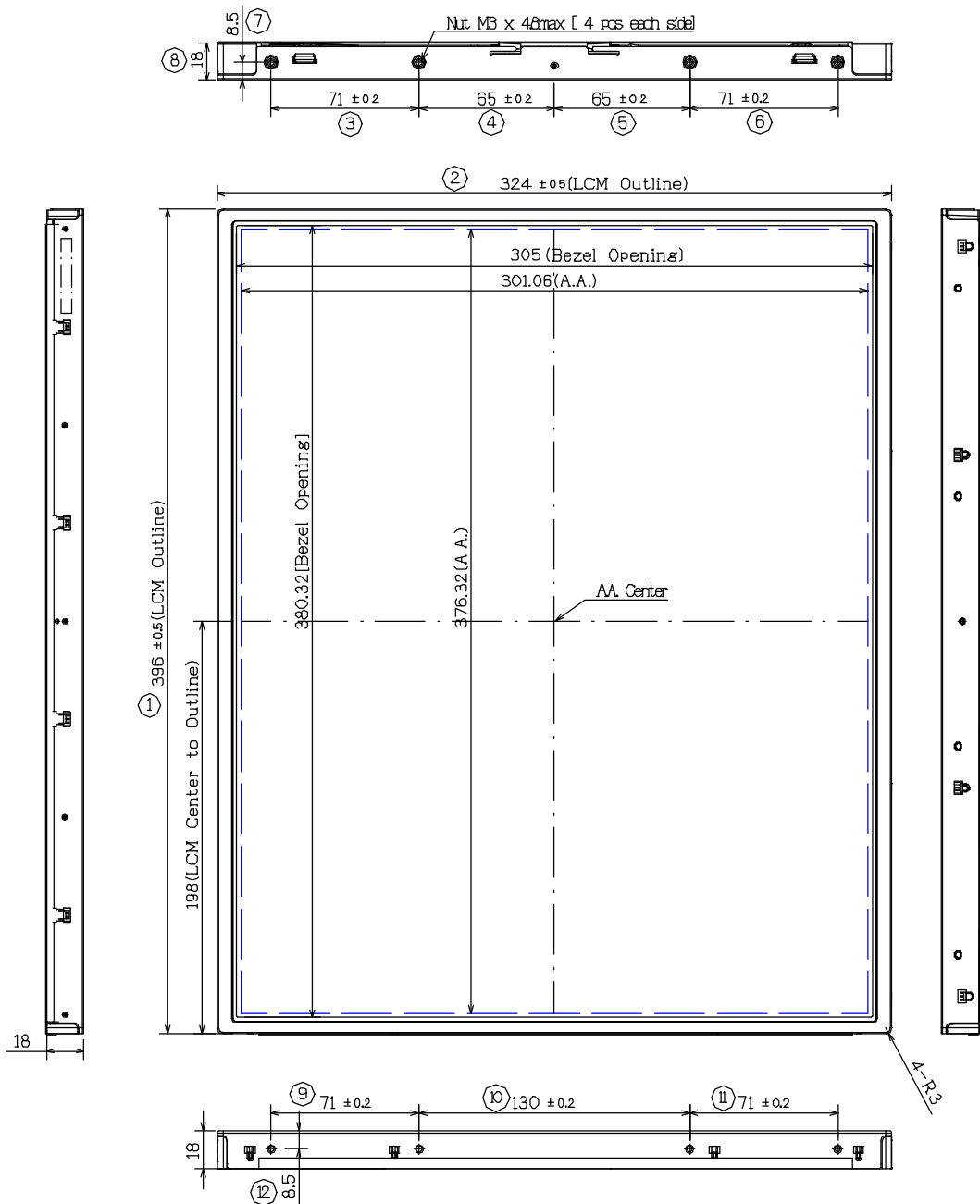

Document Title	<b>HSD190ME13- A02</b> Preliminary product information	Page No.	23 / 28
Document No.		Revision	1.0

Note: BM : | A-B | & | C-D | < 1.0mm

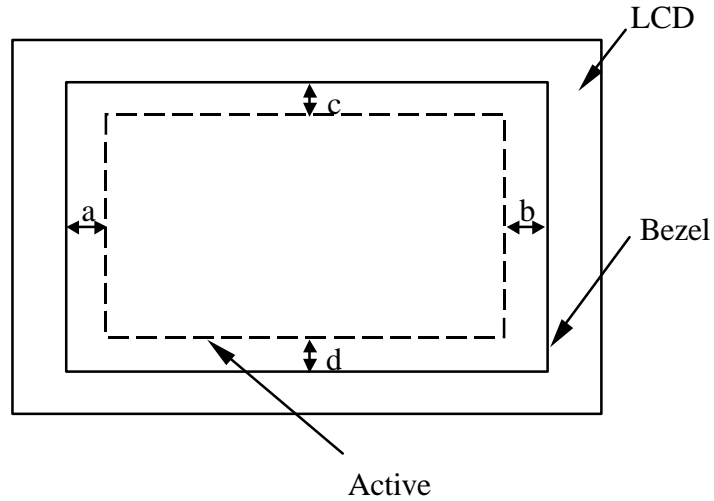



HannStar Display Corp.

Document Title	HSD190ME13- A02 Preliminary product information	Page No.	24 / 28
Document No.		Revision	1.0

8.2 Back View:

Date: 2004.12.23

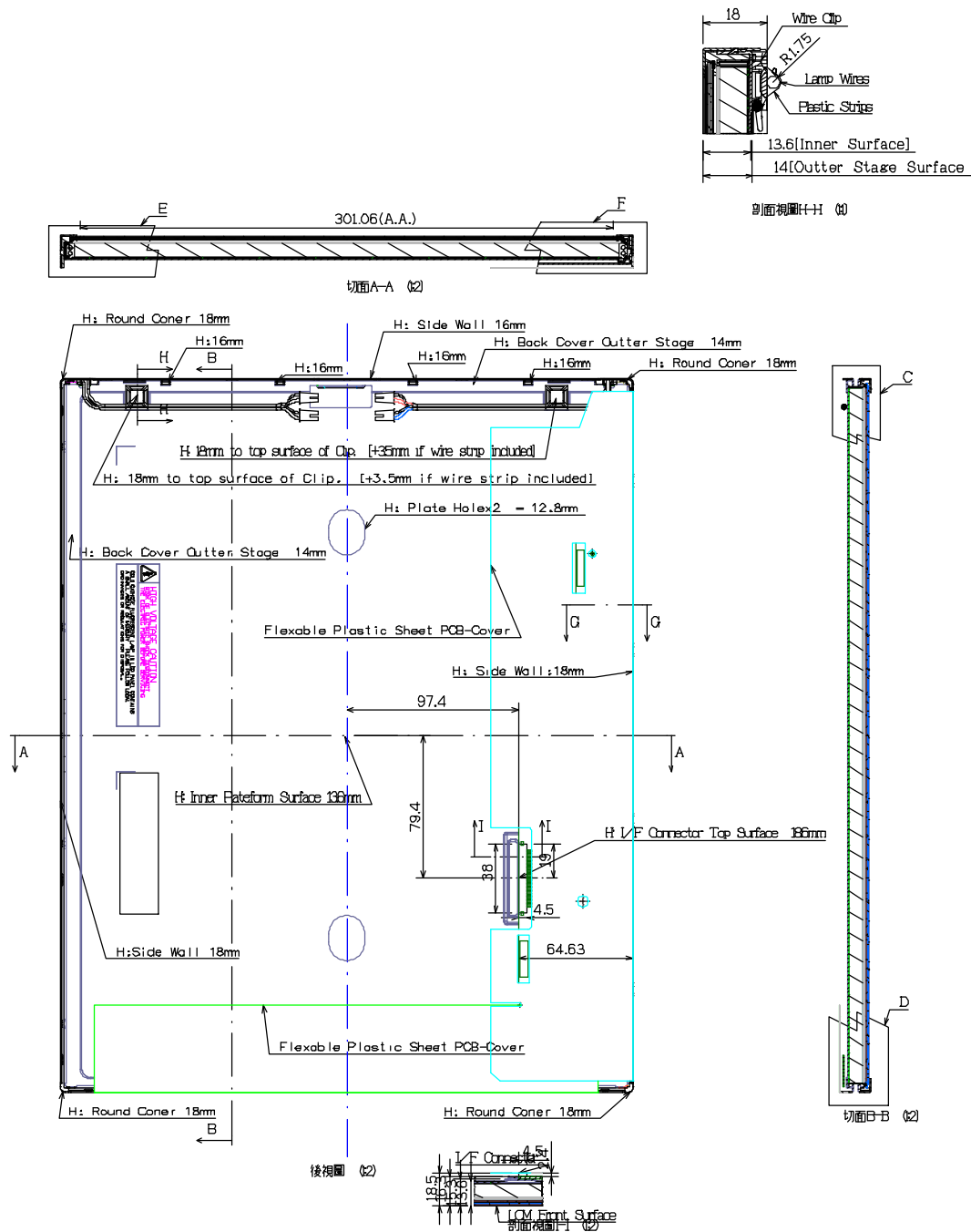



Document Title	<b>HSD190ME13- A02</b> Preliminary product information	Page No.	25 / 28
Document No.		Revision	1.0

## 9.0 LOT MARK

### 9.1 Lot Mark

1	2	3	4	5	6	7	8	9	10	11	12	13	14	15
---	---	---	---	---	---	---	---	---	----	----	----	----	----	----

code 1,2,3,4,5,6: HannStar internal flow control code.

code 7: production location.

code 8: production year.

code 9: production month.

code 10,11,12,13,14,15: serial number.

#### Note (1) Production Year

Year	1999	2000	2001	2002	2003	2004	2005	2006	2007	2008
Mark	9	0	1	2	3	4	5	6	7	8

#### Note (2) Production Month

Month	Jan.	Feb.	Mar.	Apr.	May.	Jun.	Jul.	Aug.	Sep.	Oct	Nov.	Dec.
Mark	1	2	3	4	5	6	7	8	9	A	B	C

### 9.2 Location of Lot Mark

(1) The label is attached to the backside of the LCD module.

(2) This is subject to change without prior notice.

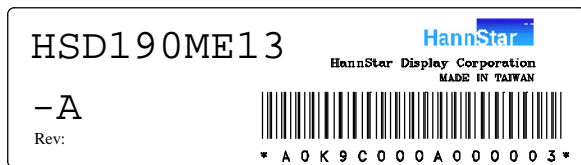

Lot mark →



HannStar Display Corp.

Document Title	HSD190ME13- A02 Preliminary product information	Page No.	26 / 28
Document No.		Revision	1.0

### 10.0 PACKAGE SPECIFICATION

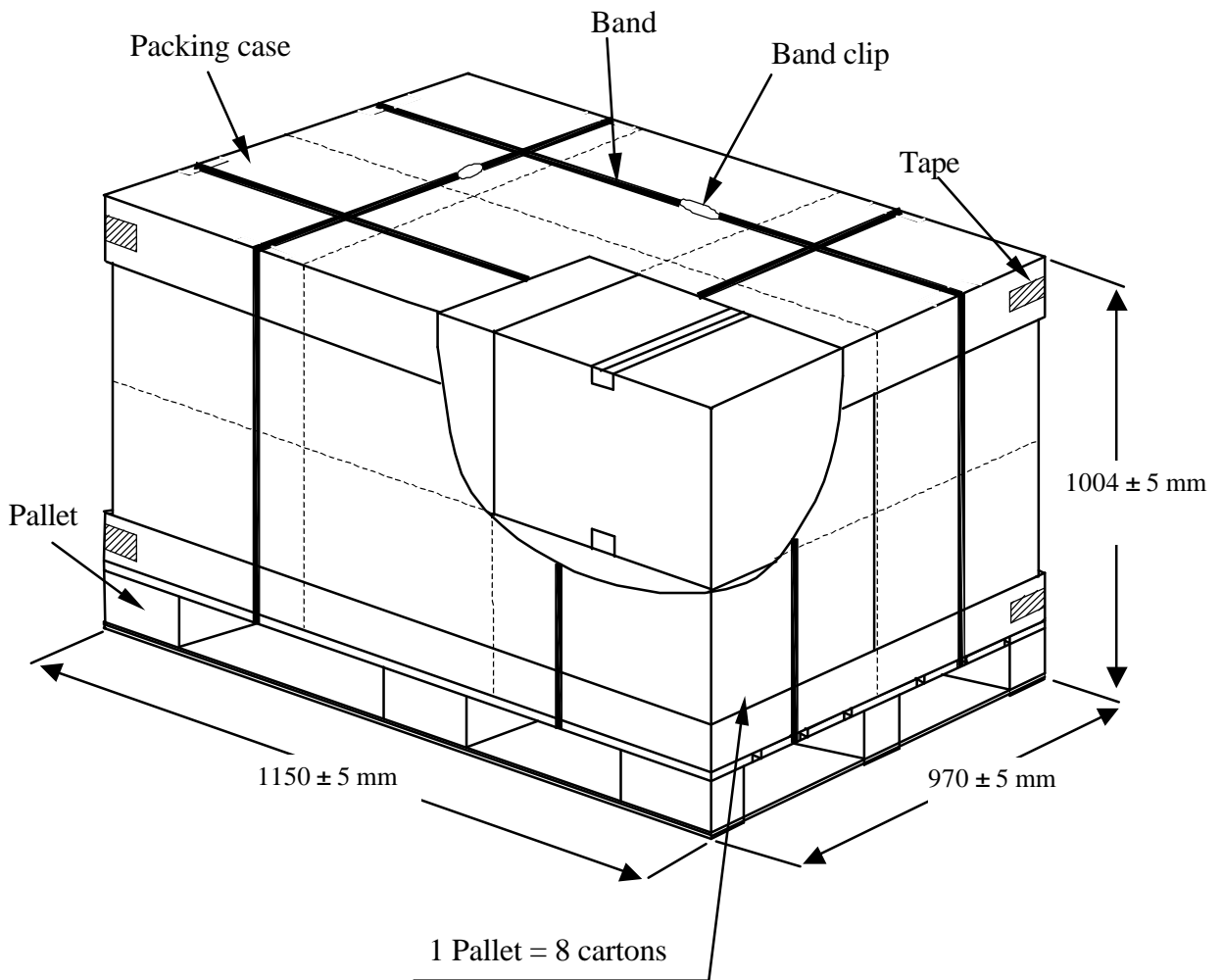



Document Title	<b>HSD190ME13- A02</b> Preliminary product information	Page No.	27 / 28
Document No.		Revision	1.0

## 11.0 GENERAL PRECAUTION

### 11.1 Use Restriction

This product is not authorized for use in life supporting systems, aircraft navigation control systems, military systems and any other application where performance failure could be life-threatening or otherwise catastrophic.

### 11.2 Disassembling or Modification

Do not disassemble or modify the module. It may damage sensitive parts inside LCD module, and may cause scratches or dust on the display. HannStar does not warrant the module, if customers disassemble or modify the module.

### 11.3 Breakage of LCD Panel

11.3.1 If LCD panel is broken and liquid crystal spills out, do not ingest or inhale liquid crystal, and do not contact liquid crystal with skin.

11.3.2 If liquid crystal contacts mouth or eyes, rinse out with water immediately.

11.3.3 If liquid crystal contacts skin or cloths, wash it off immediately with alcohol and rinse thoroughly with water.

11.3.4 Handle carefully with chips of glass that may cause injury, when the glass is broken.

### 11.4 Electric Shock

11.4.1 Disconnect power supply before handling LCD module.

11.4.2 Do not pull or fold the CCFL cable.

11.4.3 Do not touch the parts inside LCD modules and the fluorescent lamp' s connector or cables in order to prevent electric shock.

### 11.5 Absolute Maximum Ratings and Power Protection Circuit

11.5.1 Do not exceed the absolute maximum rating values, such as the supply voltage variation, input voltage variation, variation in parts' parameters, environmental temperature, etc., otherwise LCD module may be damaged.

11.5.2 Please do not leave LCD module in the environment of high humidity and high temperature for a long time.

11.5.3 It' s recommended employing protection circuit for power supply.

### 11.6 Operation

11.6.1 Do not touch, push or rub the polarizer with anything harder than HB pencil lead. Use fingerstalls of soft gloves in order to keep clean display quality, when persons

11.6.2 handle the LCD module for incoming inspection or assembly.

11.6.3 When the surface is dusty, please wipe gently with absorbent cotton or other soft material.

11.6.4 Wipe off saliva or water drops as soon as possible. If saliva or water drops contact with polarizer for a long time, they may causes deformation or color fading.



Document Title	<b>HSD190ME13- A02</b> Preliminary product information	Page No.	28 / 28
Document No.		Revision	1.0

11.6.5 When cleaning the adhesives, please use absorbent cotton wetted with a little petroleum benzine or other adequate solvent.

**11.7 Mechanism**

Please mount LCD module by using mounting holes arranged in four corners tightly.

**11.8 Static Electricity**

11.8.1 Protection film must remove very slowly from the surface of LCD module to prevent from electrostatic occurrence.

11.8.2 Because LCD module uses CMOS-IC on circuit board and TFT-LCD panel, it is very weak to electrostatic discharge. Please be careful with electrostatic discharge.

11.8.3 Persons who handle the module should be grounded through adequate methods.

**11.9 Strong Light Exposure**

The module shall not be exposed under strong light such as direct sunlight. Otherwise, display characteristics may be changed.

**11.10 Disposal**

When disposing LCD module, obey the local environmental regulations.