



**Synchronous DRAM Module 32Mbyte (4Mx64-Bit), DIMM, 4Banks, 4K Ref.,
3.3V**

Part No. HSD4M64D4B

GENERAL DESCRIPTION

The HSD4M64D4B is a 4M x 64 bit Synchronous Dynamic RAM high density memory module. The module consists of four CMOS 1M x 16 bit with 4banks Synchronous DRAMs in TSOP-II 400mil packages on a 168-pin glass-epoxy substrate. Two 0.1uF decoupling capacitors are mounted on the printed circuit board in parallel for each SDRAM. The HSD4M64D4B is a DIMM(Dual in line Memory Module) and is intended for mounting into 168-pin edge connector sockets. Synchronous design allows precise cycle control with the use of system clock. I/O transactions are possible on every clock cycle. Range of operating frequencies, programmable latencies allows the same device to be useful for a variety of high bandwidth, high performance memory system applications All module components may be powered from a single 3.3V DC power supply and all inputs and outputs are LVTTTL-compatible.

FEATURES

- Part Identification
 - HSD4M64D4B-10 : 100MHz (CL=2)
 - HSD4M64D4B-10L : 100MHz (CL=3)
 - HSD4M64D4B- 8 : 125MHz (CL=3)
- Burst mode operation
- Auto & self refresh capability (4096 Cycles/64ms)
- LVTTTL compatible inputs and outputs
- Single 3.3V \pm 0.3V power supply
- MRS cycle with address key programs
 - Latency (Access from column address)
 - Burst length (1, 2, 4, 8 & Full page)
 - Data scramble (Sequential & Interleave)
- JEDEC standard
- All inputs are sampled at the positive going edge of the system clock
- The used device is 1Mx16Bitx4Banks SDRAM

PIN ASSIGNMENT

PIN	Symbol	PIN	Symbol	PIN	Symbol	PIN	Symbol	PIN	Symbol	PIN	Symbol
1	Vss	29	DQM1	57	DQ18	85	Vss	113	DQM5	141	DQ50
2	DQ0	30	/CS0	58	DQ19	86	DQ32	114	NC	142	DQ51
3	DQ1	31	DU	59	Vcc	87	DQ33	115	/RAS	143	Vcc
4	DQ2	32	Vss	60	DQ20	88	DQ34	116	Vss	144	DQ52
5	DQ3	33	A0	61	NC	89	DQ35	117	A1	145	NC
6	Vcc	34	A2	62	NC	90	Vcc	118	A3	146	NC
7	DQ4	35	A4	63	CKE1	91	DQ36	119	A5	147	NC
8	DQ5	36	A6	64	Vss	92	DQ37	120	A7	148	Vss
9	DQ6	37	A8	65	DQ21	93	DQ38	121	A9	149	DQ53
10	DQ7	38	A10	66	DQ22	94	DQ39	122	BA0	150	DQ54
11	DQ8	39	BA1	67	DQ23	95	DQ40	123	A11	151	DQ55
12	Vss	40	Vcc	68	Vss	96	Vss	124	Vcc	152	Vss
13	DQ9	41	Vcc	69	DQ24	97	DQ41	125	CLK1	153	DQ56
14	DQ10	42	CLK0	70	DQ25	98	DQ42	126	NC	154	DQ57
15	DQ11	43	Vss	71	DQ26	99	DQ43	127	Vss	155	DQ58
16	DQ12	44	NC	72	DQ27	100	DQ44	128	CKE0	156	DQ59
17	DQ13	45	/CS2	73	Vcc	101	DQ45	129	NC	157	Vcc
18	Vcc	46	DQM2	74	DQ28	102	Vcc	130	DQM6	158	DQ60
19	DQ14	47	DQM3	75	DQ29	103	DQ46	131	DQM7	159	DQ61
20	DQ15	48	NC	76	DQ30	104	DQ47	132	NC	160	DQ62
21	NC	49	Vcc	77	DQ31	105	NC	133	Vcc	161	DQ63
22	NC	50	NC	78	Vss	106	NC	134	NC	162	Vss
23	Vss	51	NC	79	CLK2	107	Vss	135	NC	163	CLK3
24	NC	52	NC	80	NC	108	NC	136	NC	164	NC
25	NC	53	NC	81	WP	109	NC	137	NC	165	SA0
26	Vcc	54	Vss	82	SDA	110	Vcc	138	Vss	166	SA1
27	/WE	55	DQ16	83	SCL	111	/CAS	139	DQ48	167	SA2
28	DQM0	56	DQ17	84	Vcc	112	DQM4	140	DQ49	168	Vcc

PIN NAMES

Pin Name	Function	Pin Name	Function
A0 ~ A11	Address input (Multiplexed)	BA0 ~ BA1	Select bank
DQ0 ~ DQ63	Data input/output	CLK0 ~ CLK3	Clock input
CKE0 ~ CKE1	Clock enable input	CS0	Chip select input
/RAS	Row address strobe	/CAS	Column address strobe
/WE	Write enable	DQM0 ~ 7	DQM
Vcc	Power supply (3.3V)	Vss	Ground
SDA	Serial data I/O	SCL	Serial clock
DU	Do not use	NC	No connection

FUNCTIONAL BLOCK DIAGRAM

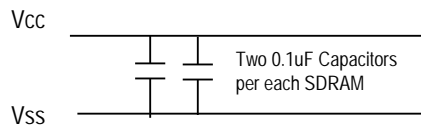
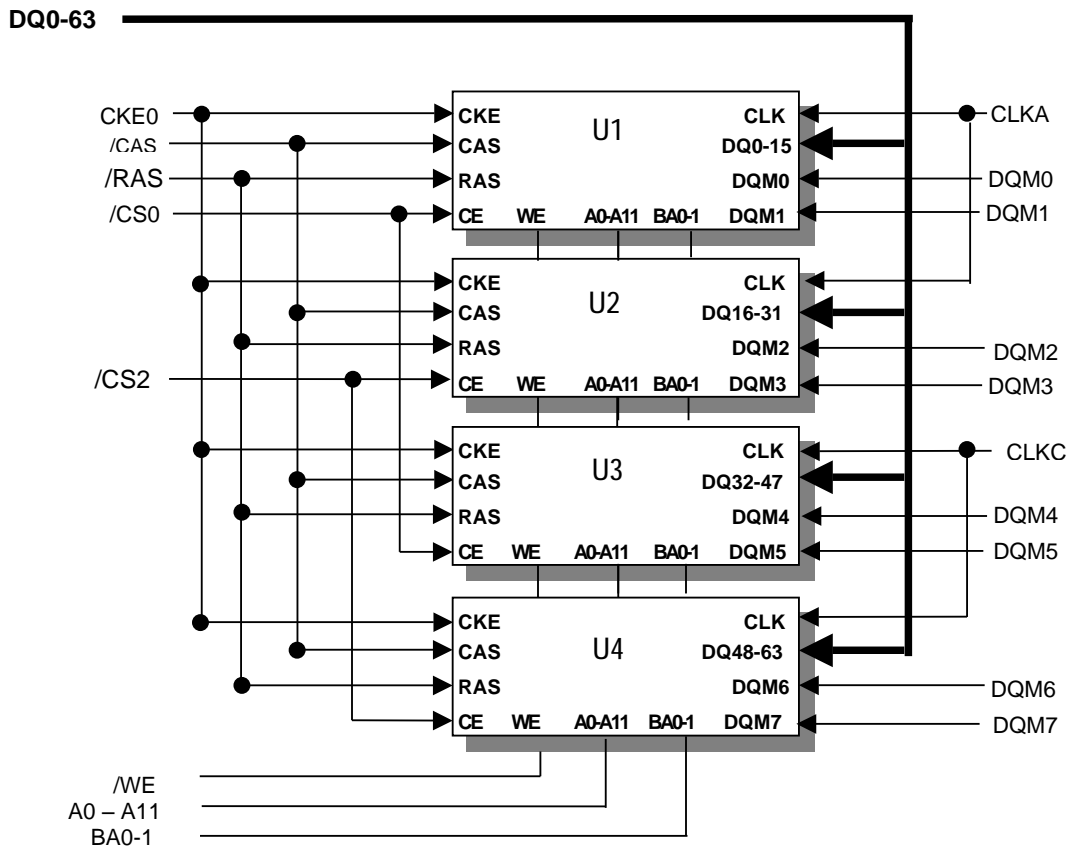

PIN FUNCTION DESCRIPTION

Pin	Name	Input Function
CLK	System clock	Active on the positive going edge to sample all inputs.
/CE	Chip enable	Disables or enables device operation by masking or enabling all inputs except CLK, CKE and DQM
CKE	Clock enable	Masks system clock to freeze operation from the next clock cycle. CKE should be enabled at least one cycle prior to new command. Disable input buffers for power down in standby. CKE should be enabled 1CLK+tSS prior to valid command.

A0 ~ A11	Address	Row/column addresses are multiplexed on the same pins. Row address : RA0 ~ RA11, Column address : CA0 ~ CA8
BA0 ~ BA1	Bank select address	Selects bank to be activated during row address latch time. Selects bank for read/write during column address latch time.
/RAS	Row address strobe	Latches row addresses on the positive going edge of the CLK with RAS low. Enables row access & precharge.
/CAS	Column address strobe	Latches column addresses on the positive going edge of the CLK with CAS low. Enables column access.
/WE	Write enable	Enables write operation and row precharge. Latches data in starting from CAS, WE active.
DQM0 ~ 7	Data input/output mask	Makes data output Hi-Z, tSHZ after the clock and masks the output. Blocks data input when DQM active. (Byte masking)
DQ0 ~ 63	Data input/output	Data inputs/outputs are multiplexed on the same pins.
Vcc/Vss	Power supply/ground	Power and ground for the input buffers and the core logic.

ABSOLUTE MAXIMUM RATINGS

PARAMETER	SYMBOL	RATING
Voltage on Any Pin Relative to Vss	V_{IN_OUT}	-1V to 4.6V
Voltage on Vcc Supply Relative to Vss	Vcc	-1V to 4.6V
Power Dissipation	P_D	4W
Storage Temperature	T_{STG}	-55°C to 150°C
Short Circuit Output Current	I_{OS}	50mA

Notes:

Permanent device damage may occur if " Absolute Maximum Ratings" are exceeded. Functional operation should be restricted to the conditions as detailed in the operational sections of this data sheet. Exposure to absolute maximum rating conditions for extended periods may affect device reliability.

DC OPERATING CONDITIONS

(Recommended operating conditions (Voltage referenced to VSS = 0V, TA = 0 to 70°C))

PARAMETER	SYMBOL	MIN	TYP.	MAX	UNIT	NOTE
Supply Voltage	Vcc	3.0	3.3	3.6	V	
Input High Voltage	V_{IH}	2.0	3.0	Vcc+0.3	V	1
Input Low Voltage	V_{IL}	-0.3	0	0.8	V	2
Output High Voltage	V_{OH}	2.4	-	-	V	$I_{OH} = -2mA$
Output Low Voltage	V_{OL}	-4	-	4	V	$I_{OL} = 2mA$
Input leakage current	I_{IL}	-1.5	-	1.5	uA	3

Notes :

1. V_{IH} (max) = 5.6V AC. The overshoot voltage duration is $\leq 3ns$.
2. V_{IL} (min) = -2.0V AC. The undershoot voltage duration is $\leq 3ns$.
3. Any input $0V \leq V_{IN} \leq V_{DDQ}$.
Input leakage currents include Hi-Z output leakage for all bi-directional buffers with Tri-State outputs.

CAPACITANCE(VCC = 3.3V, TA = 23°C, f = 1MHz, VREF = 1.4V \pm 200 mV)

DESCRIPTION	SYMBOL	MIN	MAX	UNITS
Clock	C_{CLK}	15	25	pF
/RAS, /CAS, /WE, /CS, CKE, L(U)DQM	C_{IN}	30	40	pF
Address	C_{ADD}	30	40	pF
DQ (DQ0 ~ DQ15)	C_{OUT}	5	15	pF

DC CHARACTERISTICS

(Recommended operating condition unless otherwise noted, TA = 0 to 70°C)

PARAMETER	SYMBOL	TEST CONDITION	VERSION			UNIT	NOTE
			80	10	10L		
Operating current (One bank active)	I_{CC1}	Burst length = 1 $t_{RC} \geq t_{RC}(\min)$ $I_O = 0mA$	300	280	280	mA	1
Precharge standby current in power-down mode	I_{CC2P}	$CKE \leq V_{IL}(\max)$ $t_{CC}=10ns$	4			mA	
	I_{CC2PS}	$CKE \& CLK \leq V_{IL}(\max)$ $t_{CC}=\infty$	4			mA	
Precharge standby current in non power-down mode	I_{CC2N}	$CKE \geq V_{IH}(\min)$ $CS^* \geq V_{IH}(\min)$, $t_{CC}=10ns$ Input signals are changed one time during 20ns	48			mA	
	I_{CC2NS}	$CKE \geq V_{IH}(\min)$ $CLK \leq V_{IL}(\max)$, $t_{CC}=\infty$ Input signals are stable	24				
Active standby current in power-down mode	I_{CC3P}	$CKE \leq V_{IL}(\max)$, $t_{CC}=10ns$	8			mA	
	I_{CC3PS}	$CKE \& CLK \leq V_{IL}(\max)$ $t_{CC}=\infty$	8				

Active standby current in non power-down mode (One bank active)	I_{CC3N}	CKE $\geq V_{IH}(\text{min})$, CS* $\geq V_{IH}(\text{min})$, $t_{CC}=10\text{ns}$ Input signals are changed one time during 20ns	80			mA	
	I_{CC3NS}	CKE $\geq V_{IH}(\text{min})$ CLK $\leq V_{IL}(\text{max})$, $t_{CC}=\infty$ Input signals are stable	40				
Operating current (Burst mode)	I_{CC4}	$I_O = 0 \text{ mA}$ Page burst 4Banks Activated $t_{CCD} = 2\text{CLKs}$	380	300	300	mA	1
Refresh current	I_{CC5}	$t_{RC} \geq t_{RC}(\text{min})$	500			mA	2
Self refresh current	I_{CC6}	CKE $\leq 0.2\text{V}$	4			mA	

Notes :

1. Measured with outputs open.
2. Refresh period is 64ms.

AC OPERATING TEST CONDITIONS

($V_{CC} = 3.3\text{V} \pm 0.3\text{V}$, $T_A = 0 \text{ to } 70^\circ\text{C}$)

PARAMETER	Value	UNIT
AC Input levels (V_{ih}/V_{il})	2.4/0.4	V
Input timing measurement reference level	1.4	V
Input rise and fall time	$t_r/t_f = 1/1$	ns
Output timing measurement reference level	1.4	V
Output load condition	See Fig. 2	

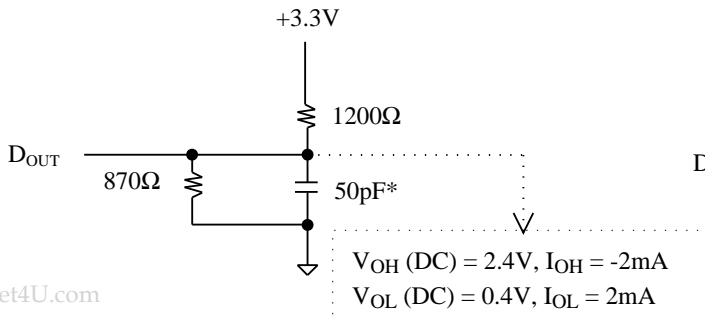

(Fig. 1) DC output load circuit

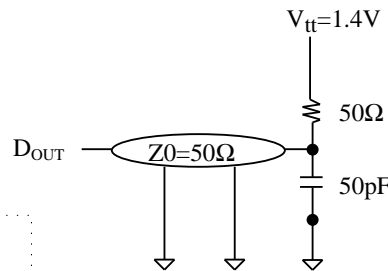

(Fig. 2) AC output load circuit

OPERATING AC PARAMETER

(AC operating conditions unless otherwise noted)

PARAMETER	SYMBOL	VERSION			UNIT	NOTE
		-80	-10	-10L		
Row active to row active delay	$t_{RRD}(\text{min})$	16	20	20	ns	1
RAS to CAS delay	$t_{RP}(\text{min})$	20	20	20	ns	1
Row precharge time	$t_{RP}(\text{min})$	20	20	20	ns	1
Row active time	$t_{RAS}(\text{min})$	48	50	50	ns	1
	$t_{RAS}(\text{max})$	100			ns	
Row cycle time	$t_{RC}(\text{min})$	68	70	70	ns	1
Last data in to row precharge	$t_{RD}(\text{min})$	1			CLK	2
Last data in to new col. address delay	$t_{CDL}(\text{min})$	1			CLK	2
Last data in to burst stop	$t_{BDL}(\text{min})$	1			CLK	2
Col. address to col. address delay	$t_{CCD}(\text{min})$	1			CLK	3
Number of valid output data	CAS latency=3	2			ea	4
	CAS latency=2	1				

Notes :

1. The minimum number of clock cycles is determined by dividing the minimum time required with clock cycle time and then rounding off to the next higher integer.
2. Minimum delay is required to complete write.
3. All parts allow every cycle column address change.
4. In case of row precharge interrupt, auto precharge and read burst stop.

AC CHARACTERISTICS

(AC operating conditions unless otherwise noted)

PARAMETER		SYMBOL	-80		-10		-10L		UNIT	NOTE
			MIN	MAX	MIN	MAX	MIN	MAX		
CLK cycle time	CAS latency=3	t_{CC}	8	1000	10	1000	10	1000	ns	1
	CAS latency=2		10		10		12			
CLK to valid output delay	CAS latency=3	t_{SAC}		6		6		6	ns	1,2
	CAS latency=2			6		6		7		
Output data hold time	CAS latency=3	t_{OH}	3		3		3		ns	2
	CAS latency=2		3		3		3			
CLK high pulse width		t_{CH}	3		3		3		ns	3

CLK low pulse width		t _{CL}	3		3		3		ns	3
Input setup time		t _{SS}	2		2		2		ns	3
Input hold time		t _{SH}	1		1		1		ns	3
CLK to output in Low-Z		t _{SLZ}	1		1		1		ns	3
CLK to output in Hi-Z	CAS latency=3	t _{SHZ}		6		6		6	ns	2
	CAS latency=2			6		6		7	ns	

Notes :

- Parameters depend on programmed CAS latency.
- If clock rising time is longer than 1ns, (tr/2-0.5)ns should be added to the parameter.
- Assumed input rise and fall time (tr & tf) = 1ns.
If tr & tf is longer than 1ns, transient time compensation should be considered, ie., [(tr + tf)/2-1]ns should be added to the parameter.

SIMPLIFIED TRUTH TABLE

COMMAND		CKE n-1	CKE N	/C S	/R A S	/C A S	/W E	D Q M	BA 0,1	A10/ AP	A11 A9~A0	NOTE
Register	Mode register set	H	X	L	L	L	L	X	OP code			1,2
Refresh	Auto refresh	H	H	L	L	L	H	X	X			3
	Self refresh		Entry	L	H	H	H	X	X			3
	Exit	L	H	L	H	H	H	X	X			3
				H	X	X	X					3
Bank active & row addr.		H	X	L	L	H	H	X	V	Row address		
Read & column address	Auto precharge disable	H	X	L	H	L	H	X	V	L	Column Address (A0 ~ A7)	4
	Auto precharge disable									H		4,5
Write & column address	Auto precharge disable	H	X	L	H	L	L	X	V	L	Column Address (A0 ~ A7)	4
	Auto precharge disable									H		4,5
Burst Stop		H	X	L	L	H	L	X	X			6
Precharge	Bank selection	H	X	L	L	H	L	X	V	L	X	
	All banks								X	H		
Clock suspend or active power down	Entry	H	L	H	X	X	X	X	X			
	Exit			L	H	X	X					X
Precharge power down mode	Entry	H	L	H	X	X	X	X	X			
				L	H	H	H					
	Exit	L	H	H	X	X	X	X				
				L	V	V	V					
DQM		H	X					V	X		7	
No operation command		H	X	H	X	X	X	X	X			
				L	H	H	H					

(V=Valid, X=Don't care, H=Logic high, L=Logic low)

Notes :

1. OP Code : Operand code
A0 ~ A11 & BA0 ~ BA1 : Program keys. (@ MRS)
2. MRS can be issued only at all banks precharge state.
A new command can be issued after 2 CLK cycles of MRS.
3. Auto refresh functions are as same as CBR refresh of DRAM.
The automatical precharge without row precharge command is meant by "Auto".
Auto/self refresh can be issued only at all banks precharge state.
4. BA0 ~ BA1 : Bank select addresses.
If both BA0 and BA1 are "Low" at read, write, row active and precharge, bank A is selected.
If both BA0 is "Low" and BA1 is "High" at read, write, row active and precharge, bank B is selected.
If both BA0 is "High" and BA1 is "Low" at read, write, row active and precharge, bank C is selected.
If both BA0 and BA1 are "High" at read, write, row active and precharge, bank D is selected.
If A10/AP is "High" at row precharge, BA0 and BA1 is ignored and all banks are selected.
5. During burst read or write with auto precharge, new read/write command can not be issued.
Another bank read/write command can be issued after the end of burst.
New row active of the associated bank can be issued at tRP after the end of burst.
6. Burst stop command is valid at every burst length.
7. DQM sampled at positive going edge of a CLK and masks the data-in at the very CLK (Write DQM latency is 0), but makes Hi-Z state the data-out of 2 CLK cycles after. (Read DQM latency is 2)

TIMING DIAGRAMS

Please refer to attached timing diagram chart (II)

PACKAGING INFORMATION

Unit : mm

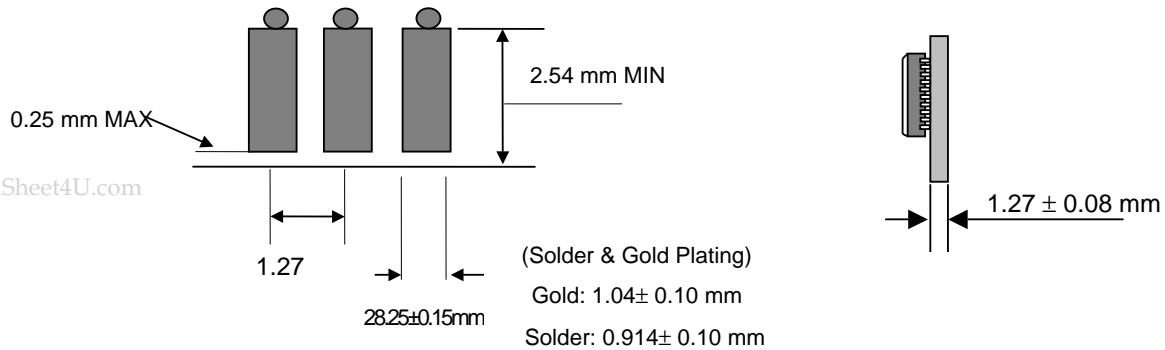
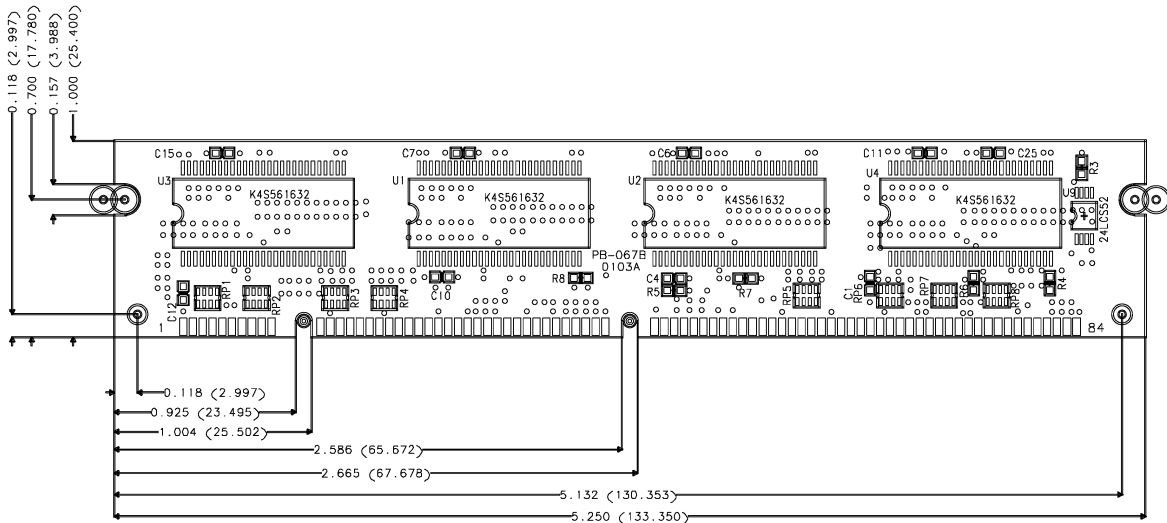

www.DataSheet4U.com

ORDERING INFORMATION

Part Number	Density	Org.	Package	Ref.	Vcc	MAX.frq
HSD4M64D4B-10	32Byte	x 64	168 Pin DIMM	4K	3.3V	100MHz (CL=2)
HSD4M64D4B-10L	32Byte	x 64	168 Pin DIMM	4K	3.3V	100MHz (CL=3)
HSD4M64D4B-12	32Byte	x 64	168 Pin DIMM	4K	3.3V	125MHz (CL=3)
HSD4M64D4B-13	32Byte	x 64	168 Pin DIMM	4K	3.3V	133MHz (CL=3)