

10/100BASE TRANSFORMER

Features:



- Designed to meet IEEE 802.3 requirements.
- Primary inductance(Lp)350uH min.@ 100KHz,0.1Vrms,8mA .
- LL:0.5uH Max @100KHz, 0.1V
- Cww:75pF Max@100KHz, 0.1V
- DCR:1.4ΩMax
- Designed to meet wave soldering 260°C.
- Storage temperature -25°C to +125°C.
- RoHS compliance

Specifications: at 25 °C.-Operating Temperature 0°Cto70°C

Part No.	Insertion loss (dB max) 0.1-100MHz	Return loss (dB typical .) MHz			CMRR (dB min .) MHz		Crosstalk (dB min .) MHz		Isolation Voltage (Vrms min)
		30	60	80	1-60	60-100	1-60	60-100	
HST-1205DR	-1.0	-16	-13	-12	-42	-35	-40	-35	1500VAC/1mA/60S

Dimension:mm(inch)Unless otherwise specified , all tolerance are +/-0.25(0.01)

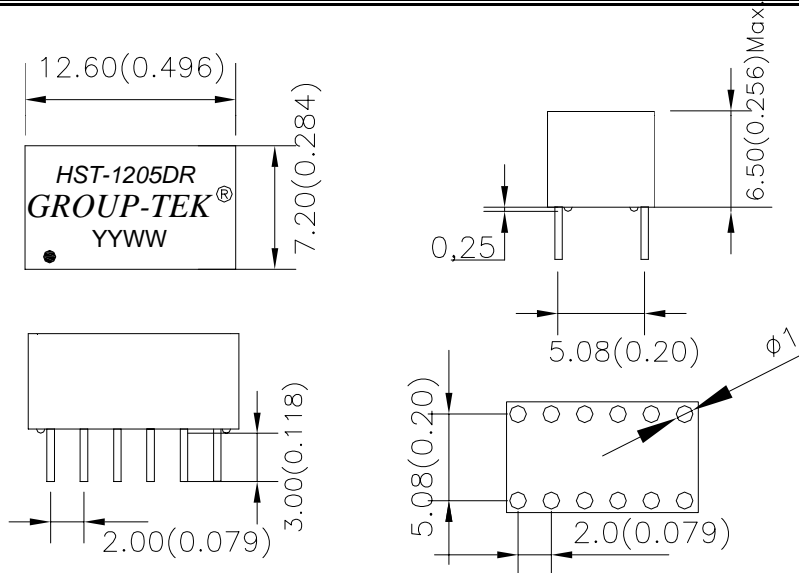

Schematic:

