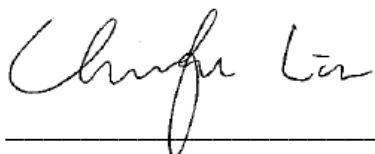

**Harvatek Surface Mount CHIP LEDs Approval Sheet****Model No.: HT-150NB****Acknowledged by****Section Manager  
Production Engineering Dept.****Manager  
Production Engineering Dept.**

Official Product	HT Part No. HT-150NB	Your Part No.		Data Sheet No.
Tentative Product	*****	*****		HDS-150-K051
Specifications are subject to changes for improvement without advance notice. Proprietary data, drawings, and company confidential all rights reserved.		2005/1/18	Version of 1.0	Page 1/12

**INTRODUCTION** ..... 3

**PRODUCT SPECIFICATION** ..... 4

**LABEL SPEC.:** ..... 5

PRODUCT FEATURE..... 7

ELECTRO-OPTICAL CHARACTERISTICS ..... 7

PACKAGE OUTLINE DIMENSION AND RECOMMENDED SOLDERING PATTERN FOR REFLOW SOLDERING. 7

ABSOLUTE MAXIMUM RATINGS ..... 7

CHARACTERISTICS..... 8

**PACKAGING TAPE, REEL, AND PACKING MODEL** ..... 9

TAPE DIMENSION..... 9

REEL DIMENSION ..... 9

PACKING MODEL ..... 10

**DRY PACK**..... 10

**CAUTIONS OF PICK AND PLACE** ..... 11

**PRECAUTIONS**..... 11

REFLOW SOLDERING ..... 11

REWORK..... 12

CLEANING ..... 12

Official Product	HT Part No. HT-150NB	Your Part No.		Data Sheet No.
Tentative Product	*****	*****		HDS-150-K051
Specifications are subject to changes for improvement without advance notice. Proprietary data, drawings, and company confidential all rights reserved.		2005/1/18	Version of 1.0	Page 2/12

## Introduction

- *The information contained herein is presented only as a guide for the applications of our products. No responsibility is assumed by HARVATEK for any infringements of intellectual property or other rights of the third parties which may result from it use.*
- *Harvatek is continually effort to improve the quality of its products. Nevertheless, semiconductor devices in general can malfunction or fail due to their inherent electrical sensitivity and vulnerability to physical stress. It is the responsibility of the buyer, when utilizing HARVATEK products, to comply with the standards of safety in making a safe design for the entire system, and to avoid situations in which a malfunction or failure of such HARATEK products cause loss of human life, bodily injury or damage to property.*
- *The HARVATEK products listed in this document are intended for usage in general electronics (computer, personal equipment, office equipment, industrial robotics, domestic, etc...) These products are neither intended nor warranted for usage in equipment that requires extraordinarily high quality and/or reliability or a malfunction or failure of which may cause loss of human life or bodily injury.*
- *In developing your designs, please ensure that HARVATEK products are used within specified operating ranges as set forth in the most recent HARVATEK products specifications.*
- *Also, please keep in mind the precautions listed in this document.*

Official Product	HT Part No. HT-150NB	Your Part No.		Data Sheet No.
Tentative Product	*****	*****		HDS-150-K051
Specifications are subject to changes for improvement without advance notice. Proprietary data, drawings, and company confidential all rights reserved.		2005/1/18	Version of 1.0	Page 3/12

## Product Specification

	Specification	Material	Quantity
Iv	45-112.5 mcd @20mA/ Ta= 25° C Tolerance: ± 10%		
Lambda(λ <sub>D</sub> )	464-476 nm @20mA/ Ta= 25° C Tolerance: ± 0.5nm		
Vf	2.9-3.9V @20mA/ Ta= 25° C Tolerance: ± 0.5v		
Ir	< 100 μA @ V <sub>R</sub> = 5 V		
Resin	Milky Diffused	Epoxy resin	
Carrier tape	According to EIA 481-1A specs	Conductive tape	3000pcs per reel
Reel	According to EIA 481-1A specs	Conductive	
Label	HT standard	Paper	
Packing bag	220x240mm	Aluminum laminated bag/ no-zipper	One reel one bag
Carton	HT standard	Paper	Non-specified

Others:

Every mid-box will be loaded 5 reels. These 5 reels can be different in lot, Iv, lambda, or Vf. Every reel will have an independent label to identify its specification and the mid-box there will have a corresponding label post on it.



ESD protection for GaP and AlGaAs chips are still necessary even though they are safety in low static-electric discharge. Material in AlInGaP, GaN, or/and InGaN chips are **STATIC SENSITIVE device**. ESD protection shall be considered and taken in the initial design stage.

If manual work/process is needed, please ensure the device is well protective from ESD within all the process.

Official Product	HT Part No. HT-150NB	Your Part No.		Data Sheet No.
Tentative Product	*****	*****		HDS-150-K051
Specifications are subject to changes for improvement without advance notice. Proprietary data, drawings, and company confidential all rights reserved.		2005/1/18	Version of 1.0	Page 4/12

**Label Spec.:**

<b>HARVATEK</b>		Date: yyyy/mm/dd 
CUSTOMER P/N: 		
HARVATEK P/N: 	QTY: PCS 	
LOT NO: 	QC	
IV BIN:    COLOR BIN:    VF:		

■ **Customer P/N: To Be Defined**

■ **Harvatek P/N**

**H T - 1 5 0 NB**

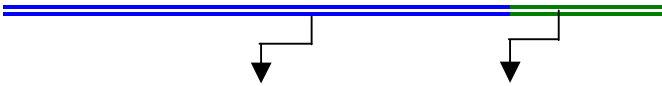

Series Name	Emitting Color
HT-150: 3.2x1.6x1.1mm	NB: Blue @20mA

■ **Lot No.**

1    2    3    4    5    6    7    8    9    10  
**P 1 2 2 3 0 A - D T**

Code 1	Code 2	Code 3	Code 4, 5	Code 6, 7	Code 9	Code 10
	Mfg. Year	Mfg. Month	Mfg. Date	Lots	Resin Color	Packaging
Internal Tracing Code	Z: 2000 1: 2001 2: 2002 3: 2003 .....	1: Jan. 2: Feb. .... 9: Sep. A: Oct. B: Nov. C: Dec.	1~31/ (30)	01~99, A,B,C...	D: Milky White	T: Taped Reel

Official Product	HT Part No. HT-150NB	Your Part No.		Data Sheet No.
Tentative Product	*****	*****		HDS-150-K051
Specifications are subject to changes for improvement without advance notice. Proprietary data, drawings, and company confidential all rights reserved.		2005/1/18	Version of 1.0	Page 5/12

■ Iv Bin:

Color	Bin Code	Spec. Range
Blue	P	45-72mcd
	Q	72-112.5mcd

■ Color Bin:

Color	Bin Code	Spec. Range
Blue	B	464-468nm
	C	468-472nm
	D	472-476nm

■ Vf Bin:

Color	Bin Code	Spec. Range
Blue	H7	2.9-3.1V
	H8	3.1-3.3V
	J7	3.3-3.5V
	J8	3.5-3.7V
	K7	3.7-3.9V

Official Product	HT Part No. HT-150NB	Your Part No.		Data Sheet No.
Tentative Product	*****	*****		HDS-150-K051
Specifications are subject to changes for improvement without advance notice. Proprietary data, drawings, and company confidential all rights reserved.		2005/1/18	Version of 1.0	Page 6/12

## Product Feature

### Electro-Optical Characteristics

(I<sub>F</sub> @ 20mA, T<sub>a</sub> 25 °C)

Code for parts	Lighting Color	Material	V <sub>F</sub> (V)		λ(nm)			I <sub>v</sub> (mcd)
			typ	max	λ <sub>D</sub>	λ <sub>P</sub>	Δλ	Typ
HT-150NB	Blue	InGaN	3.3	3.9	470	468	40	72

### Package Outline Dimension and Recommended Soldering Pattern for Reflow Soldering

Unit: mm Tolerance: +/-0.1

Outline Dim.	Soldering Pattern

1. Soldering terminal may shift in x, y direction.

### Absolute Maximum Ratings

(T<sub>a</sub> 25 °C)

Series	P <sub>d</sub> (mW)	I <sub>F</sub> (mA)	I <sub>FP</sub> (mA)	V <sub>R</sub> (V)	T <sub>OP</sub> (°C)	T <sub>ST</sub> (°C)
HT-150NB	78	20	80**	5	-30~+80	-40~+85

\*\* Condition for I<sub>FP</sub> is pulse of 1/10 duty and 0.1msec width

Official Product	HT Part No. HT-150NB	Your Part No.		Data Sheet No.
Tentative Product	*****	*****		HDS-150-K051
Specifications are subject to changes for improvement without advance notice. Proprietary data, drawings, and company confidential all rights reserved.		2005/1/18	Version of 1.0	Page 7/12

## Characteristics

Forward Current vs. Ambient Temperature

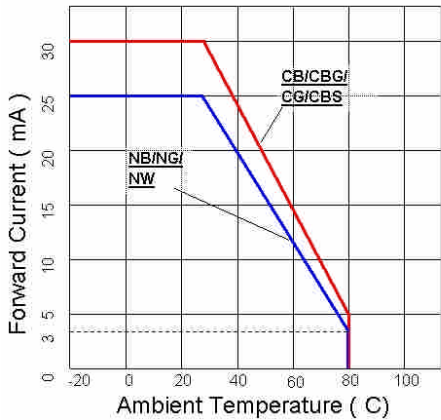

Forward Voltage vs. Forward Current

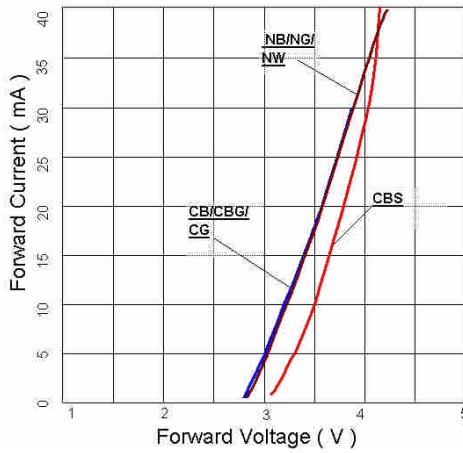

Relative Intensity vs. Forward Current

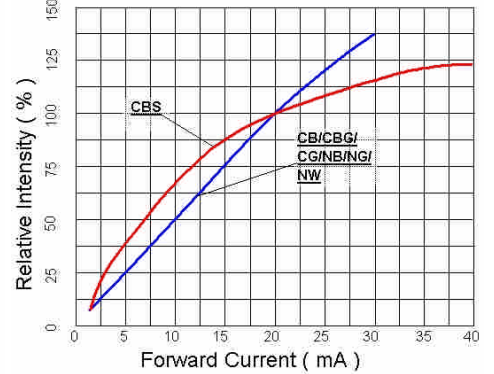

Relative Intensity vs. Ambient Temperature  
Plused 20mA; 300us pulse, 10ms period

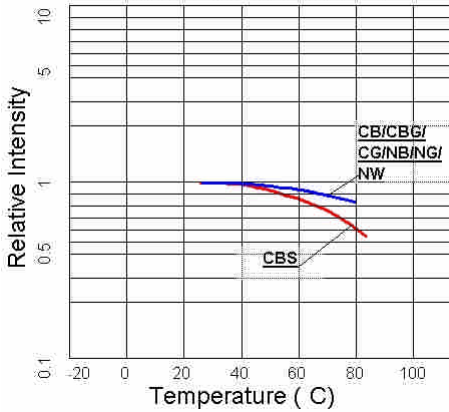

Relative Intensity vs. Wavelength

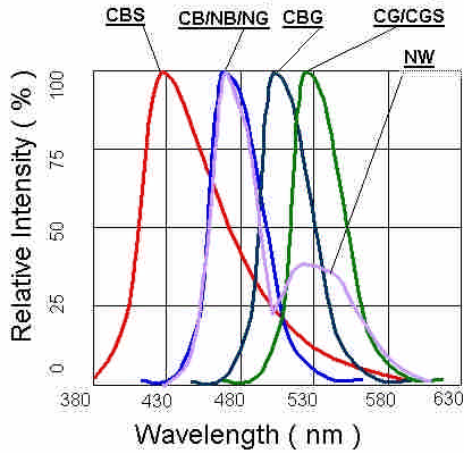

Peak Forward Voltage vs. Forward Current  
100's test pulse, 1% duty cycle

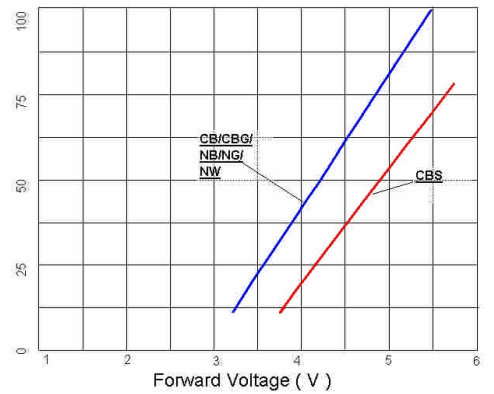

## Directive Characteristics

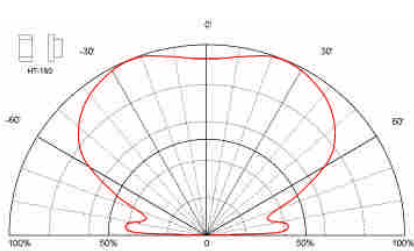

## Directive Characteristics

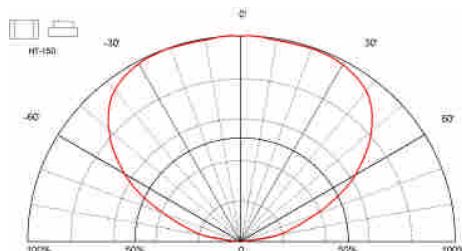

Official Product	HT Part No. HT-150NB	Your Part No.	Data Sheet No.
Tentative Product	*****	*****	HDS-150-K051
Specifications are subject to changes for improvement without advance notice. Proprietary data, drawings, and company confidential all rights reserved.		2005/1/18	Version of 1.0
			Page 8/12



## Packaging Tape, Reel, and Packing Model Tape Dimension

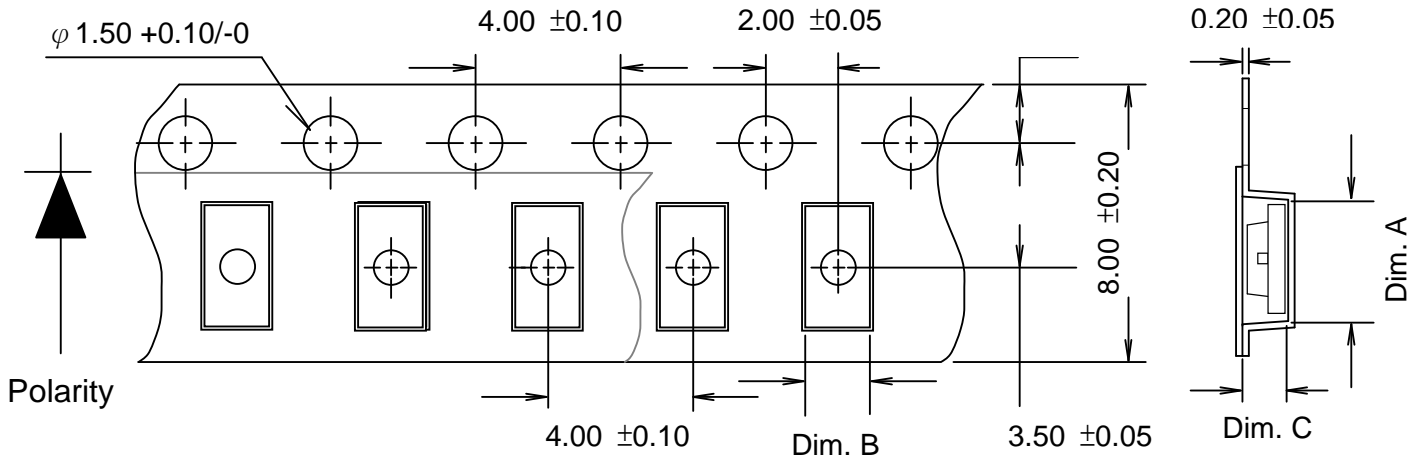

Part No.	Dim. A	Dim. B	Dim. C	Q'ty/Reel
HT-150	3.50±0.10	1.88±0.10	1.27±0.10	3K

Unit: mm

## Reel Dimension

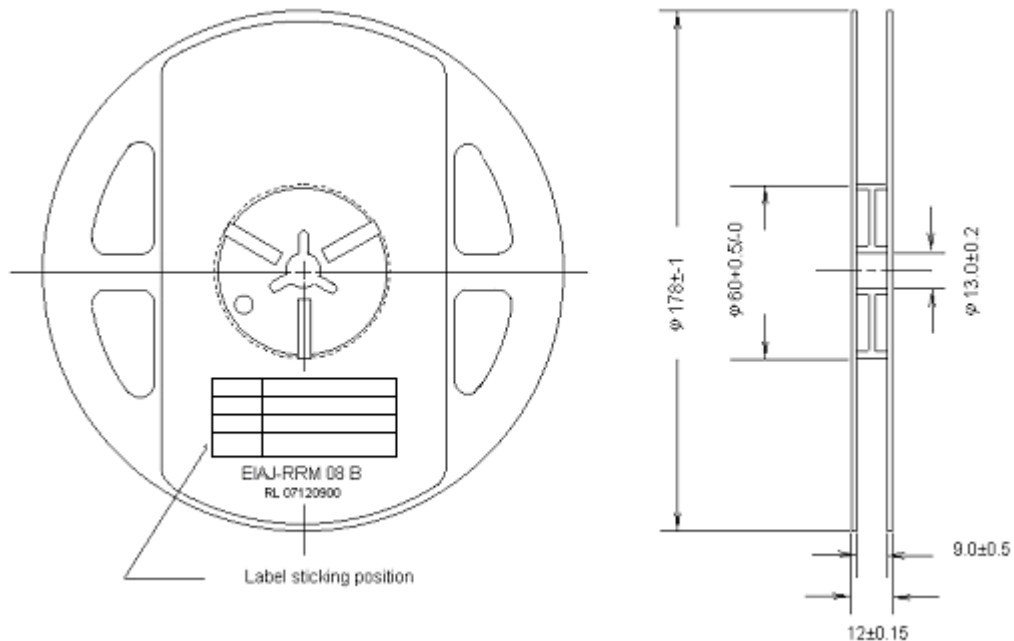

Official Product	HT Part No. HT-150NB	Your Part No.		Data Sheet No.
Tentative Product	*****	*****		HDS-150-K051
Specifications are subject to changes for improvement without advance notice. Proprietary data, drawings, and company confidential all rights reserved.		2005/1/18	Version of 1.0	Page 9/12

## Packing Model

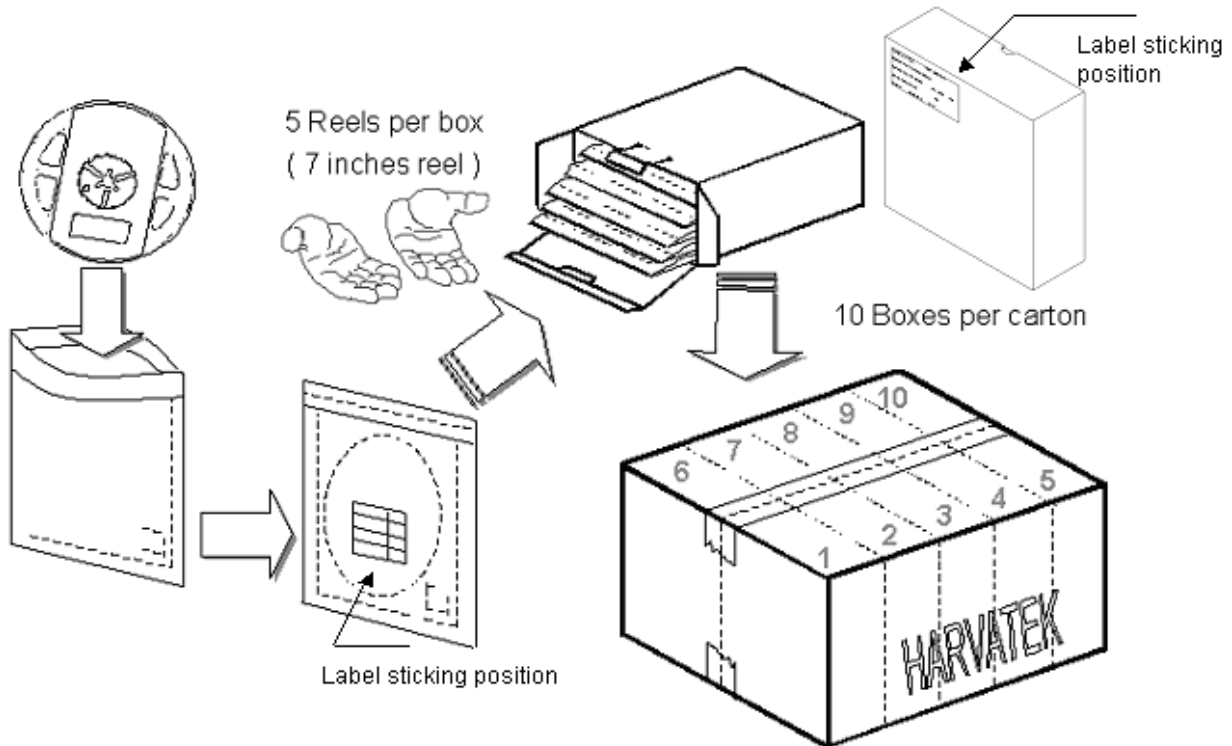

5 boxes per carton is available according to shipping quantity.

### Dry Pack

Any SMD optical device, like this chip LED, is **MOISTURE SENSITIVE device**. Avoid absorbing moisture at any time during transportation or storage. Every reel will be packaged in the moisture barrier anti-static bag (Specific bag material will depend upon customers' requirement or option). And the bag is well sealed before shipment.

By customer's requirement, we will put a humidity indicator in each moisture barrier anti-static bag before shipment.

The package is the following:

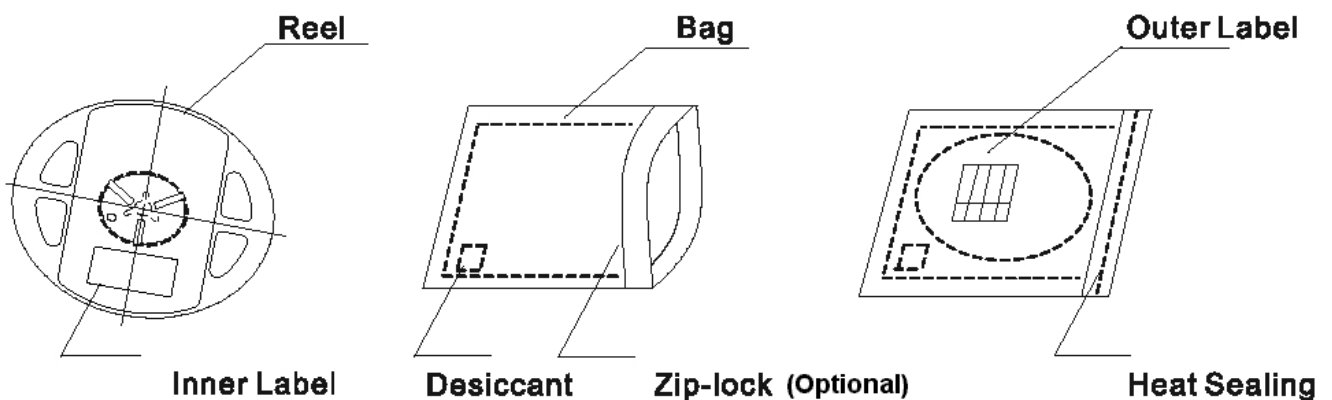

Official Product	HT Part No. HT-150NB	Your Part No.	Data Sheet No.
Tentative Product	*****	*****	HDS-150-K051
Specifications are subject to changes for improvement without advance notice. Proprietary data, drawings, and company confidential all rights reserved.	2005/1/18	Version of 1.0	Page 10/12

### Cautions of Pick and Place

It should be avoided to load stress on the resin during high temperature.

Avoid rubbing or scraping the resin by any object.

Electric-static may cause damage to the component. Please confirm that the equipment grounding well. Using an ionizer fan is recommended.

### PRECAUTIONS

1. Avoid absorbing moisture at any time during transportation or storage.
2. Anti-Static process is needed especially when handling GaN, InGaN, and AlInGaP products.
3. It is suggested to connect the unit with a proper series current limit resistor. Avoid driving reverse voltage over the specification of LEDs when turning the unit ON/OFF.
4. Any application should refer to the specifications of absolute maximum ratings.
5. Avoid any direct contact with the viewing area.
6. If possible, assemble the unit in a clean room or dust-free environment.

### Reflow Soldering

- ◆ Recommend tin glue specifications:  
Melting temperature: 178~192 °C
- ◆ Never take next process until the component is cooled down to room temperature after reflow.
- ◆ The recommended reflow soldering profile (measuring on the surface of the LED resin) is following:

Lead Solder

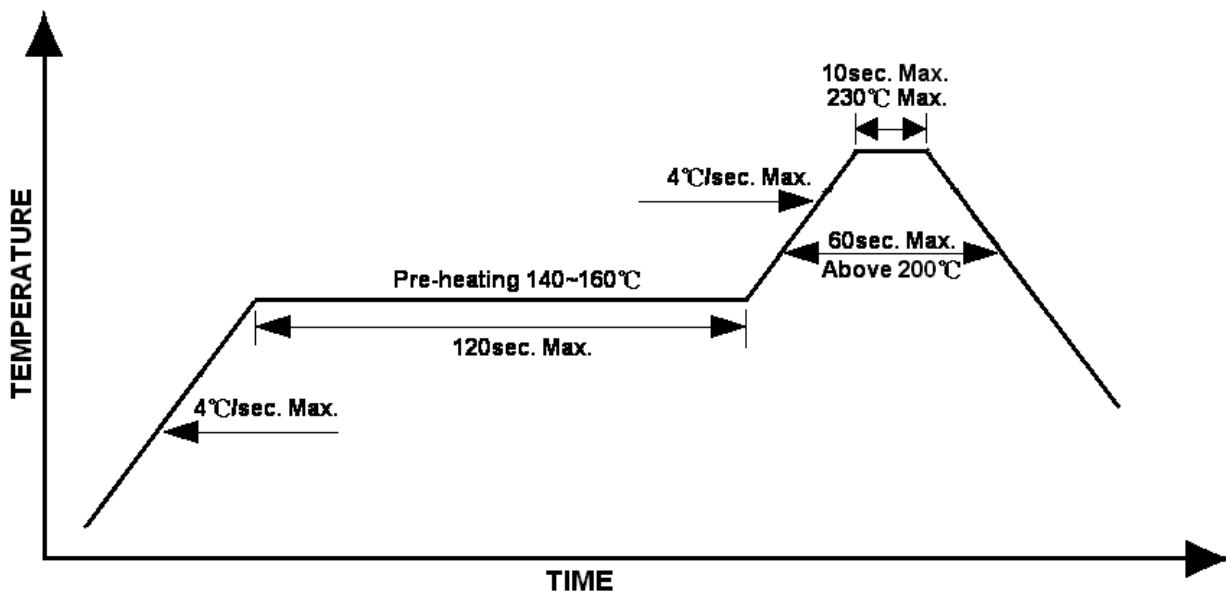

Official Product	HT Part No. HT-150NB	Your Part No.		Data Sheet No.
Tentative Product	*****	*****		HDS-150-K051
Specifications are subject to changes for improvement without advance notice. Proprietary data, drawings, and company confidential all rights reserved.		2005/1/18	Version of 1.0	Page 11/12

Lead-free Solder

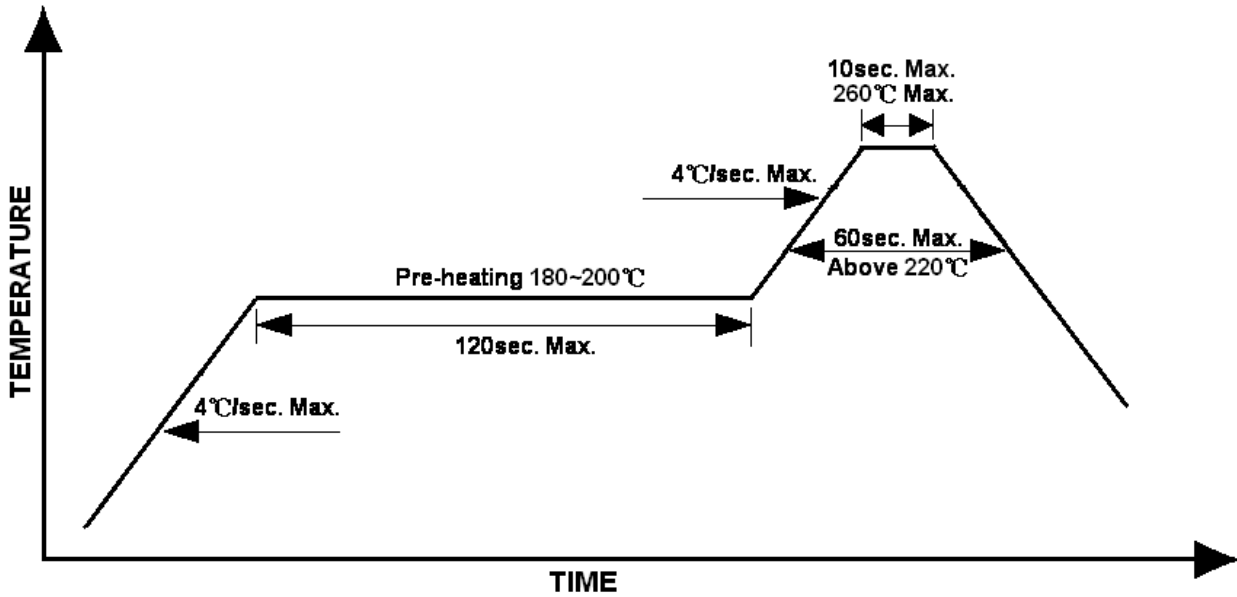

**Rework**

- ◆ Customer must finish rework within 5 sec. under 260 °C.
- ◆ The head of iron cannot touch copper foil.
- ◆ Twin-head type is preferred.

**Cleaning**

The conditions of cleaning after soldering:

An alcohol-based solvent such as isopropyl alcohol (IPA) is recommended.

Temperature×Time: <50 °C×30sec, or <30 °C×3min

Ultra sonic cleaning: < 15W/ bath; Bath volume: 1liter max.

Curing: 100 °C max, <3min

Do not contact with component on the assembly board.

Official Product	HT Part No. HT-150NB	Your Part No.		Data Sheet No.
Tentative Product	*****	*****		HDS-150-K051
Specifications are subject to changes for improvement without advance notice. Proprietary data, drawings, and company confidential all rights reserved.		2005/1/18	Version of 1.0	Page 12/12