



**PROPRIETARY NOTE**

THIS SPECIFICATION IS THE PROPERTY OF BOE OT AND SHALL NOT BE REPRODUCED OR COPIED WITHOUT THE WRITTEN PERMISSION OF BOE OT AND MUST BE RETURNED TO BOE OT UPON ITS REQUEST

**TITLE : HT101WSB-100**  
**Product Specification**  
**Rev. 0**

**BEIJING BOE OPTOELECTRONICS TECHNOLOGY**

SPEC. NUMBER S864-5046	PRODUCT GROUP TFT-LCD	REV. 0	ISSUE DATE 2009.5.31.	PAGE 1 OF 35
---------------------------	--------------------------	-----------	--------------------------	-----------------





**PRODUCT GROUP**

REV

ISSUE DATE

TFT LCD PRODUCT

0

2009.5.31.

**Contents**

No.	Items	Page
1.0	General Description	4
2.0	Absolute Maximum ratings	6
3.0	Electrical specifications.	7
4.0	Optical specifications.	9
5.0	Interface Connection	14
6.0	Signal Timing Specification	18
7.0	Signal Timing waveforms	20
8.0	Input Signals, Display Colors & Gray Scale of Colors	22
9.0	Power Sequence	23
10.0	Connector description	24
11.0	Mechanical Characteristics	25
12.0	Reliability Test	26
13.0	Handling & Cautions.	26
14.0	Label	27
15.0	Packing information	29
16.0	Mechanical Outline Dimension	30
17.0	EDID Table	32

SPEC. NUMBER

SPEC TITLE

HT101WSB-100 Product Specification

PAGE

3 OF 35

S864-5046

B2006-5006-O (3/3)

A4(210 X 297)

## 1.0 GENERAL DESCRIPTION

### 1.1 Introduction

HT101WSB-100 is a color active matrix TFT LCD module using amorphous silicon TFT's (Thin Film Transistors) as an active switching devices. This module has a 10.1 inch diagonally measured active area with WSVGA resolutions (1024 horizontal by 600 vertical pixel array). Each pixel is divided into RED, GREEN, BLUE dots which are arranged in vertical Stripe and this module can display 262,144 colors. The TFT-LCD panel used for this module is a low reflection type. Therefore, this module is suitable for Notebook and Mini-Notebook PC.

The LED Driver for back-light driving is built in this model.

All input signals are LVDS interface compatible.

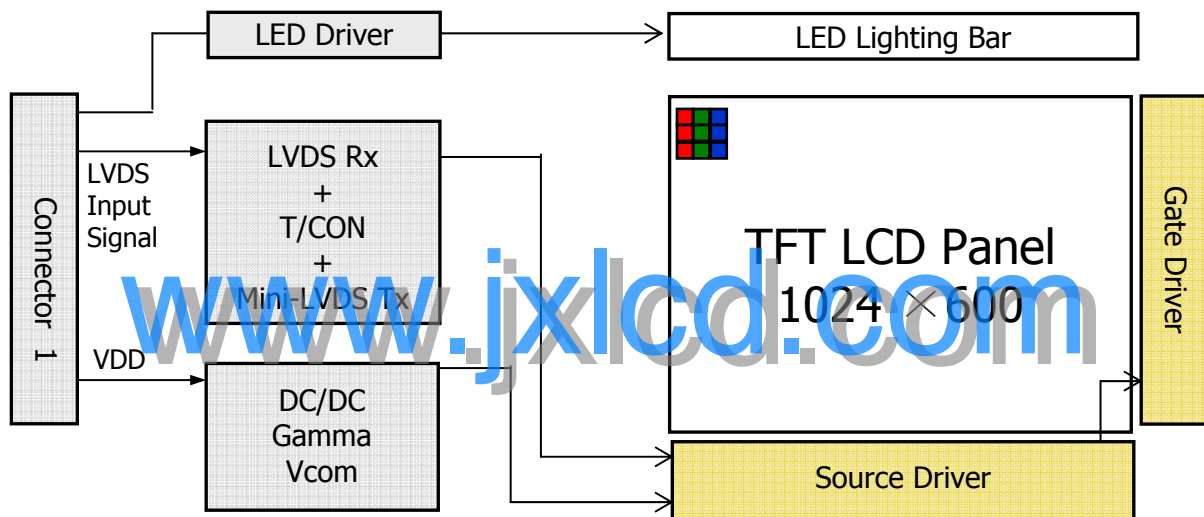

### 1.2 Features

- 1 Channel LVDS Interface with 1 pixel / clock
- Thin and light weight
- 6-bit color depth, display 262K colors
- Single LED Lighting Bar. (Top side/Horizontal Direction)
- Data enable signal mode
- Side Mounting Frame
- Green Product (RoHS & Halogen free product)
- On board LED Driving circuit
- Low driving voltage and low power consumption
- On board EDID chip

SPEC. NUMBER

SPEC TITLE

HT101WSB-100 Product Specification

PAGE

4 OF 35

S864-5046

B2006-5006-O (3/3)

A4(210 X 297)



# PRODUCT GROUP

REV

ISSUE DATE

TFT LCD PRODUCT

0

2009.5.31.

## 1.3 Application

- Notebook PC (Wide type)

## 1.4 General Specification

The followings are general specifications at the model HT101WSB-100. (listed in Table 1.)

<Table 1. General Specifications>

Parameter	Specification	Unit	Remarks
Active area	222.72(H) × 125.28(V)	mm	
Number of pixels	1024 (H) × 600 (V)	pixels	
Pixel pitch	0.2175 (H) × 0.2088 (V)	mm	
Pixel arrangement	RGB Vertical stripe		
Display colors	262K	colors	
Display mode	Normally White		
Dimensional outline	235.5(H)(max.) × 143.5 (V)(max.) × 5.2(D)(max)	mm	
Weight	190 (max)	g	
Surface treatment	Glare,3H		
Back-light	Upper edge side, 1-LED Lighting Bar type		Note 1
Power consumption	$P_D$ : 0.5	W	
	$P_{BL}$ : 1.9	W	
	$P_{total}$ : 2.7 (max)	W	

Notes : 1. LED Lighting Bar (27\*LED Array)

SPEC. NUMBER

SPEC TITLE

HT101WSB-100 Product Specification

PAGE

5 OF 35

S864-5046

B2006-5006-O (3/3)

A4(210 X 297)



# PRODUCT GROUP

REV

ISSUE DATE

TFT LCD PRODUCT

0

2009.5.31.

## 2.0 ABSOLUTE MAXIMUM RATINGS

The followings are maximum values which, if exceed, may cause faulty operation or damage to the unit. The operational and non-operational maximum voltage and current values are listed in Table 2.

< Table 2. Absolute Maximum Ratings >

Ta=25+/-2°C

Parameter	Symbol	Min.	Max.	Unit	Remarks
Power Supply Voltage	V <sub>DD</sub>	-0.3	4.0	V	Note 1
Logic Supply Voltage	V <sub>IN</sub>	V <sub>SS</sub> -0.3	V <sub>DD</sub> +0.3	V	
Operating Temperature	T <sub>OP</sub>	0	+50	°C	Note 2
Storage Temperature	T <sub>ST</sub>	-20	+60	°C	

- Notes : 1. Permanent damage to the device may occur if maximum values are exceeded functional operation should be restricted to the condition described under normal operating conditions.
2. Temperature and relative humidity range are shown in the figure below.  
 95 % RH Max. (40 °C ≥ Ta)  
 Maximum wet - bulb temperature at 39 °C or less. (Ta > 40 °C) No condensation.

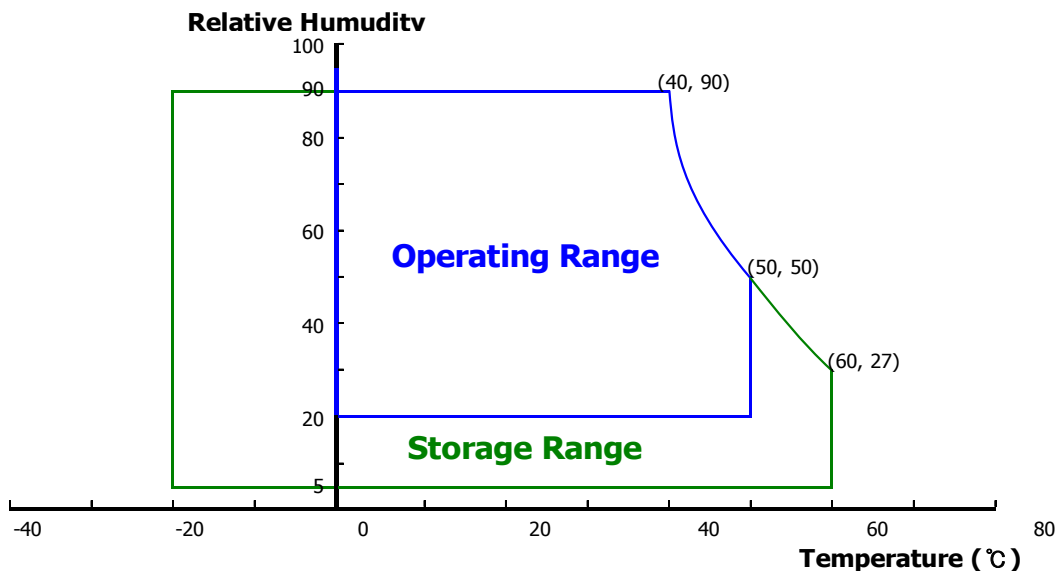

SPEC. NUMBER

SPEC TITLE

HT101WSB-100 Product Specification

PAGE

6 OF 35

S864-5046

B2006-5006-O (3/3)

A4(210 X 297)

### 3.0 ELECTRICAL SPECIFICATIONS

#### 3.1 Electrical Specifications

&lt; Table 3. Electrical specifications &gt;

Ta=25+/-2°C

Parameter		Min.	Typ.	Max.	Unit	Remarks
Power Supply Voltage	V <sub>DD</sub>	3.0	3.3	3.6	V	Note 1
Permissible Input Ripple Voltage	V <sub>RF</sub>	-	-	100	mV	At V <sub>DD</sub> = 3.3V
In-Rush Current	I <sub>RUSH</sub>			460	mA	Note 2
Power Supply Current	I <sub>DD</sub>	-	150	200	mA	Note 1
Positive-going Input Threshold Voltage	V <sub>IT+</sub>	-	-	100	mV	V <sub>cm</sub> = 1.2V typ.
Negative-going Input Threshold Voltage	V <sub>IT-</sub>	-100	-	-	mV	
Differential Input Voltage	V <sub>ID</sub>	200	-	600	mV	Note 2
Power Consumption	P <sub>D</sub>	-	0.5	0.66	W	Note 1
	P <sub>BL</sub>	-	-	1.9	W	Note 3
	P <sub>total</sub>	-	-	2.7	W	

Notes : 1. The supply voltage is measured and specified at the interface connector of LCM.  
The current draw and power consumption specified is for 3.3V at 25°C.

a) Typ : Window XP pattern

b) Max : Vertical 2 line skip pattern

2. Duration of rush current is about 2ms and rising time of VDD is 520us ± 20%.

3. Calculated value for reference (VF × IF)

SPEC. NUMBER

SPEC TITLE

HT101WSB-100 Product Specification

PAGE

7 OF 35

S864-5046

B2006-5006-O (3/3)

A4(210 X 297)



# PRODUCT GROUP

REV

ISSUE DATE

TFT LCD PRODUCT

0

2009.5.31.

## 3.0 ELECTRICAL SPECIFICATIONS

### 3.2 Backlight Unit

< Table 4. LED Driving guideline specifications >

Ta=25+/-2°C

Parameter		Min.	Typ.	Max.	Unit	Remarks
LED Forward Voltage	V <sub>F</sub>	3.0	3.2	3.4	V	-
LED Forward Current	I <sub>F</sub>	-	20		mA	-
LED Power Consumption	P <sub>LED</sub>			1.9	W	Note 1
LED Life-Time	N/A	10,000	-	-	Hour	I <sub>F</sub> = 20mA
PWM Control Frequency	F <sub>PWM</sub>	200	-	1000	Hz	V <sub>cm</sub> = 1.2V
Duty Ratio		20		100	%	

Notes : 1. Calculator Value for reference  $I_F \times V_F = P$

2. The LED Life-time define as the estimated time to 50% degradation of initial luminous.

SPEC. NUMBER

SPEC TITLE

HT101WSB-100 Product Specification

PAGE

8 OF 35

S864-5046

B2006-5006-O (3/3)

A4(210 X 297)





# PRODUCT GROUP

REV

ISSUE DATE

TFT LCD PRODUCT

0

2009.5.31.

## 4.0 OPTICAL SPECIFICATION

### 4.1 Overview

The test of Optical specifications shall be measured in a dark room (ambient luminance  $\leq 1$  lux and temperature =  $25 \pm 2^\circ\text{C}$ ) with the equipment of Luminance meter system (Goniometer system and TOPCON BM-5) and test unit shall be located at an approximate distance 50cm from the LCD surface at a viewing angle of  $\Theta$  and  $\Phi$  equal to  $0^\circ$ . We refer to  $\Theta \emptyset = 0$  ( $= \Theta 3$ ) as the 3 o'clock direction (the "right"),  $\Theta \emptyset = 90$  ( $= \Theta 12$ ) as the 12 o'clock direction ("upward"),  $\Theta \emptyset = 180$  ( $= \Theta 9$ ) as the 9 o'clock direction ("left") and  $\Theta \emptyset = 270$  ( $= \Theta 6$ ) as the 6 o'clock direction ("bottom"). While scanning  $\Theta$  and/or  $\emptyset$ , the center of the measuring spot on the Display surface shall stay fixed. The backlight should be operating for 30 minutes prior to measurement. VDD shall be  $3.3 \pm 0.3\text{V}$  at  $25^\circ\text{C}$ . Optimum viewing angle direction is 6 'clock.

### 4.2 Optical Specifications

<Table 5. Optical Specifications>

Parameter		Symbol	Condition	Min.	Typ.	Max.	Unit	Remark
Viewing Angle range	Horizontal	$\Theta_3$	CR > 10	-	45	-	Deg.	Note 1
		$\Theta_9$		-	45	-	Deg.	
	Vertical	$\Theta_{12}$		15	-	-	Deg.	
		$\Theta_6$		-	35	-	Deg.	
Luminance Contrast ratio		CR	$\Theta = 0^\circ$	400	500			Note 2
Luminance of White	5 Points	$Y_w$	$\Theta = 0^\circ$ $I_{LED} = 20\text{mA}$	170	200	-	cd/m <sup>2</sup>	Note 3
White Luminance uniformity	5 Points	$\Delta Y_5$		80	-	-		Note 4
	13 Points	$\Delta Y_{13}$		65	-	-		
White Chromaticity		$x_w$	$\Theta = 0^\circ$	0.283	0.313	0.343		Note 5
		$y_w$		0.299	0.329	0.359		
Reproduction of color	Red	$x_R$	$\Theta = 0^\circ$	-	0.579	-		
		$y_R$		-	0.343	-		
	Green	$x_G$		-	0.336	-		
		$y_G$		-	0.592	-		
	Blue	$x_B$		-	0.152	-		
		$y_B$		-	0.117	-		
Response Time (Rising + Falling)		$T_{RT}$	$T_a = 25^\circ\text{C}$ $\Theta = 0^\circ$	-	8	16	ms	Note 6
Cross Talk		CT	$\Theta = 0^\circ$	-	-	2.0	%	Note 7

SPEC. NUMBER

SPEC TITLE

HT101WSB-100 Product Specification

PAGE

9 OF 35

S864-5046

B2006-5006-O (3/3)

A4(210 X 297)



**PRODUCT GROUP**

REV

ISSUE DATE

TFT LCD PRODUCT

0

2009.5.31.

Notes : 1. Viewing angle is the angle at which the contrast ratio is greater than 10. The viewing angles are determined for the horizontal or 3, 9 o'clock direction and the vertical or 6, 12 o'clock direction with respect to the optical axis which is normal to the LCD surface (see FIGURE 1).

2. Contrast measurements shall be made at viewing angle of  $\theta = 0$  and at the center of the LCD surface. Luminance shall be measured with all pixels in the view field set first to white, then to the dark (black) state . (see FIGURE 1) Luminance Contrast Ratio (CR) is defined mathematically.

$$CR = \frac{\text{Luminance when displaying a white raster}}{\text{Luminance when displaying a black raster}}$$

3. Center Luminance of white is defined as luminance values of 5 point average across the LCD surface. Luminance shall be measured with all pixels in the view field set first to white. This measurement shall be taken at the locations shown in FIGURE 2 for a total of the measurements per display.

4. The White luminance uniformity on LCD surface is then expressed as :  $\Delta Y = \text{Minimum Luminance of 5(or 13) points} / \text{Maximum Luminance of 5(or 13) points}$  (see FIGURE 2 and FIGURE 3).

5. The color chromaticity coordinates specified in Table 5 shall be calculated from the spectral data measured with all pixels first in red, green, blue and white. Measurements shall be made at the center of the panel.

6. The electro-optical response time measurements shall be made as FIGURE 4 by switching the "data" input signal ON and OFF. The times needed for the luminance to change from 10% to 90% is  $T_r$ , and 90% to 10% is  $T_d$ .

7. Cross-Talk of one area of the LCD surface by another shall be measured by comparing the luminance (YA) of a 25mm diameter area, with all display pixels set to a gray level, to the luminance (YB) of that same area when any adjacent area is driven dark. (See FIGURE 5).

SPEC. NUMBER

SPEC TITLE

HT101WSB-100 Product Specification

PAGE

10 OF 35

S864-5046

B2006-5006-O (3/3)

A4(210 X 297)

**4.3 Optical measurements**

**Figure 1. Measurement Set Up**

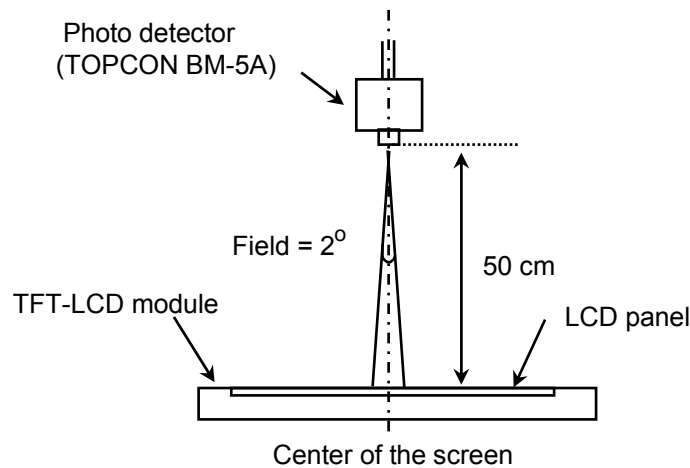

Optical characteristics measurement setup

**Figure 2. White Luminance and Uniformity Measurement Locations (5 points)**

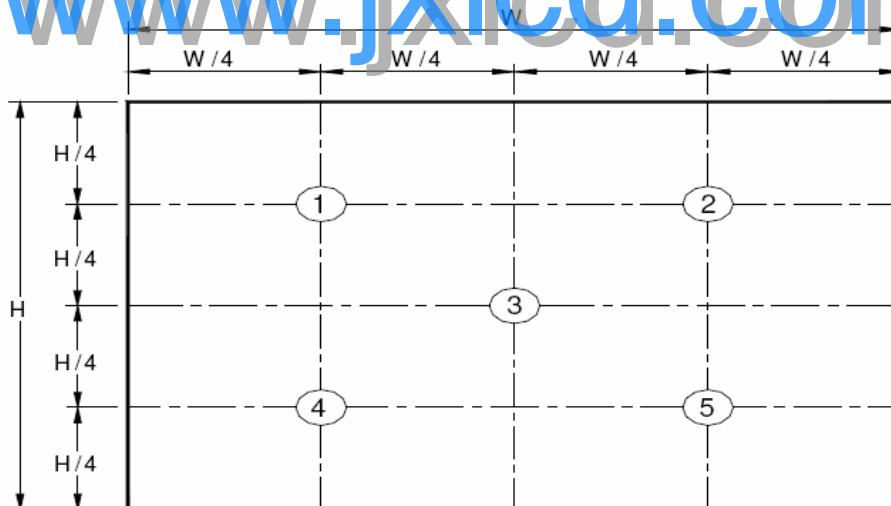

Center Luminance of white is defined as luminance values of center 5 points across the LCD surface. Luminance shall be measured with all pixels in the view field set first to white. This measurement shall be taken at the locations shown in FIGURE 2 for a total of the measurements per display.

SPEC. NUMBER

SPEC TITLE

HT101WSB-100 Product Specification

PAGE

11 OF 35

S864-5046

B2006-5006-O (3/3)

A4(210 X 297)

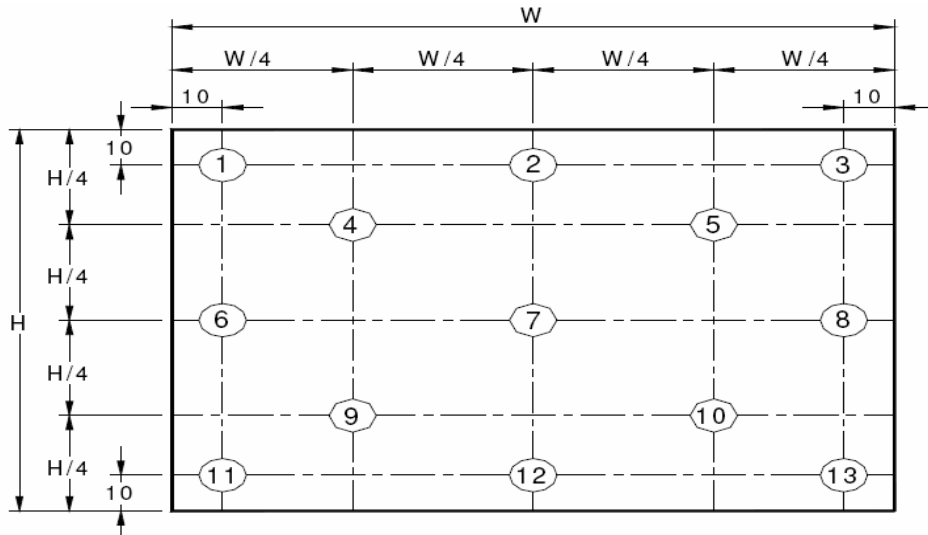
**Figure 3. Uniformity Measurement Locations (13 points)**

The White luminance uniformity on LCD surface is then expressed as :  $\Delta Y5 = \text{Minimum Luminance of five points} / \text{Maximum Luminance of five points}$  (see FIGURE 2) ,  $\Delta Y13 = \text{Minimum Luminance of 13 points} / \text{Maximum Luminance of 13 points}$  (see FIGURE 3).

[www.jxlcd.com](http://www.jxlcd.com)

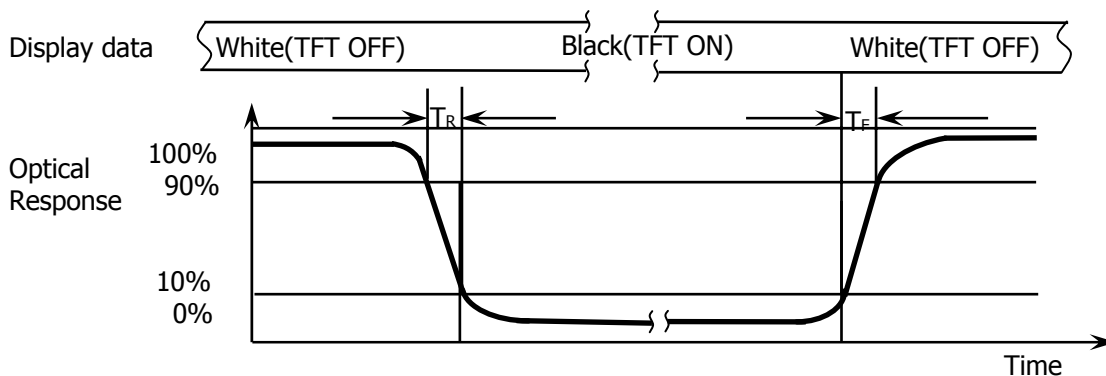
**Figure 4. Response Time Testing**

The electro-optical response time measurements shall be made as shown in FIGURE 4 by switching the “data” input signal ON and OFF. The times needed for the luminance to change from 10% to 90% is  $T_d$  and 90% to 10% is  $T_r$ .

SPEC. NUMBER

SPEC TITLE

HT101WSB-100 Product Specification

PAGE

12 OF 35

S864-5046

B2006-5006-O (3/3)

A4(210 X 297)

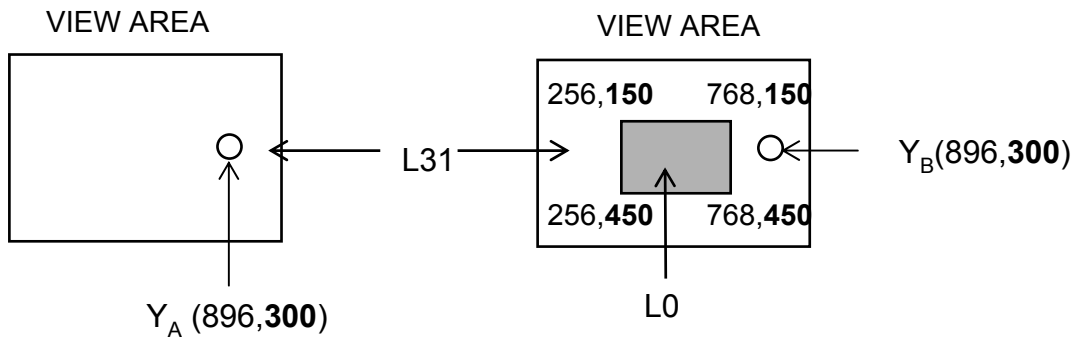
**Figure 5. Cross Modulation Test Description**

$$\text{Cross-Talk (\%)} = \left| \frac{Y_B - Y_A}{Y_B} \right| \times 100$$

Where:

 $Y_A$  = Initial luminance of measured area (cd/m<sup>2</sup>)

 $Y_B$  = Subsequent luminance of measured area (cd/m<sup>2</sup>)

The location measured will be exactly the same in both patterns

Cross-Talk of one area of the LCD surface by another shall be measured by comparing the luminance ( $Y_A$ ) of a 25mm diameter area, with all display pixels set to a gray level, to the luminance ( $Y_B$ ) of that same area when any adjacent area is driven dark (Refer to FIGURE 5).

## 5.0 INTERFACE CONNECTION.

### 5.1 Electrical Interface Connection

The electronics interface connector is I-PEX 20455-040E-12 or Compatible or equivalent. The mating connector part number is I-PEX 20455-040T-11 or Compatible. The connector interface pin assignments are listed in Table 6.

<Table 6. Pin Assignments for the Interface Connector>

Terminal	Symbol	Functions
Pin No.	Symbol	Description
1	NC	No Connection (Reserve)
2	VDDIN	Power Supply, 3.3V (typ.)
3	VDDIN	Power Supply, 3.3V (typ.)
4	VDC	VDC 3.3V power for EDID
5	NC	NC No Connection (Reserve)
6	CLK EDID	EDID Clock
7	Data EDID	EDID Data
8	RxIN0-	Transmission Data of 0 Negative -
9	RxIN0+	Transmission Data of 0 Positive +
10	GND	Ground
11	RxIN1-	Transmission Data of 1 Negative -
12	RxIN1+	Transmission Data of 1 Positive +
13	GND	Ground
14	RxIN2-	Transmission Data of 2 Negative -
15	RxIN2+	Transmission Data of 2 Positive +
16	GND	Ground
17	RxCLKIN-	Sampling Clock of Negative -
18	RxCLKIN+	Sampling Clock of Positive +
19	GND	Ground
20	NC	No Connection
21	NC	No Connection
22	GND	Ground
23	NC	No Connection
24	NC	No Connection
25	GND	Ground
26	NC	No Connection
27	NC	No Connection
28	GND	Ground
29	NC	No Connection
30	NC	No Connection

SPEC. NUMBER

SPEC. TITLE

S864-5046

HT101WSB-100 Product Specification

PAGE

14 OF 35

**PRODUCT GROUP**

REV

ISSUE DATE

TFT LCD PRODUCT

0

2009.5.31.

<b>Terminal</b>	<b>Symbol</b>	<b>Functions</b>
Pin No.	Symbol	Description
31	VLED_GND	LED Ground
32	VLED_GND	LED Ground
33	VLED_GND	LED Ground
34	NC	No Connection
35	PWM	System PWM Signal Input
36	LED_EN	LED enable pin(+3.3V Input)
37	NC	No Connection (Reserve)
38	VLED	LED Power Supply 12V (typ.)
39	VLED	LED Power Supply 12V (typ.)
40	VLED	LED Power Supply 12V (typ.)

[www.jxlcd.com](http://www.jxlcd.com)

SPEC. NUMBER

SPEC TITLE

HT101WSB-100 Product Specification

S864-5046

PAGE

15 OF 35

B2006-5006-O (3/3)

A4(210 X 297)

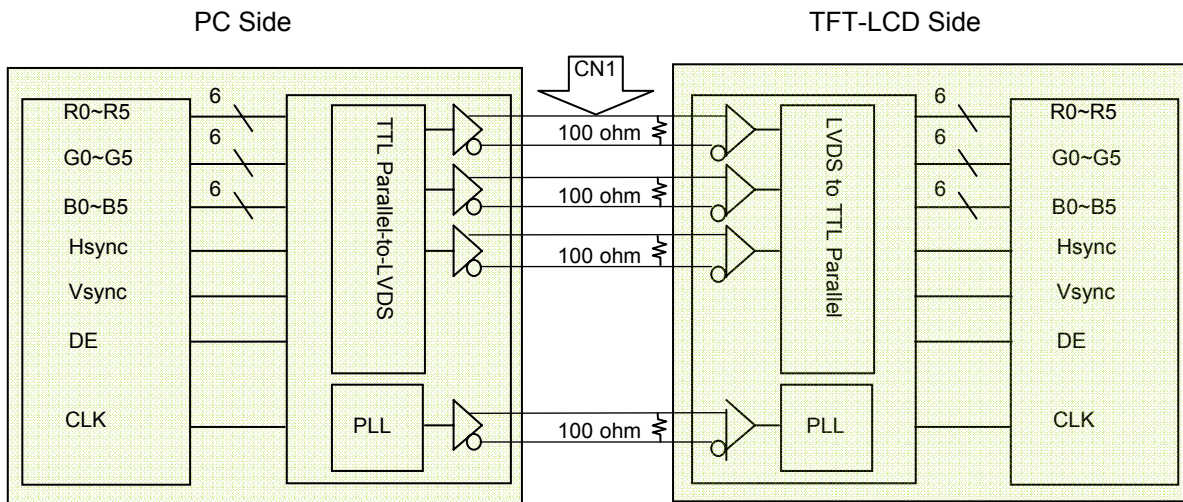
**5-2. LVDS Interface**

Note. Transmitter : Thine THC63LVDM63A or equivalent.  
Transmitter is not contained in Module.

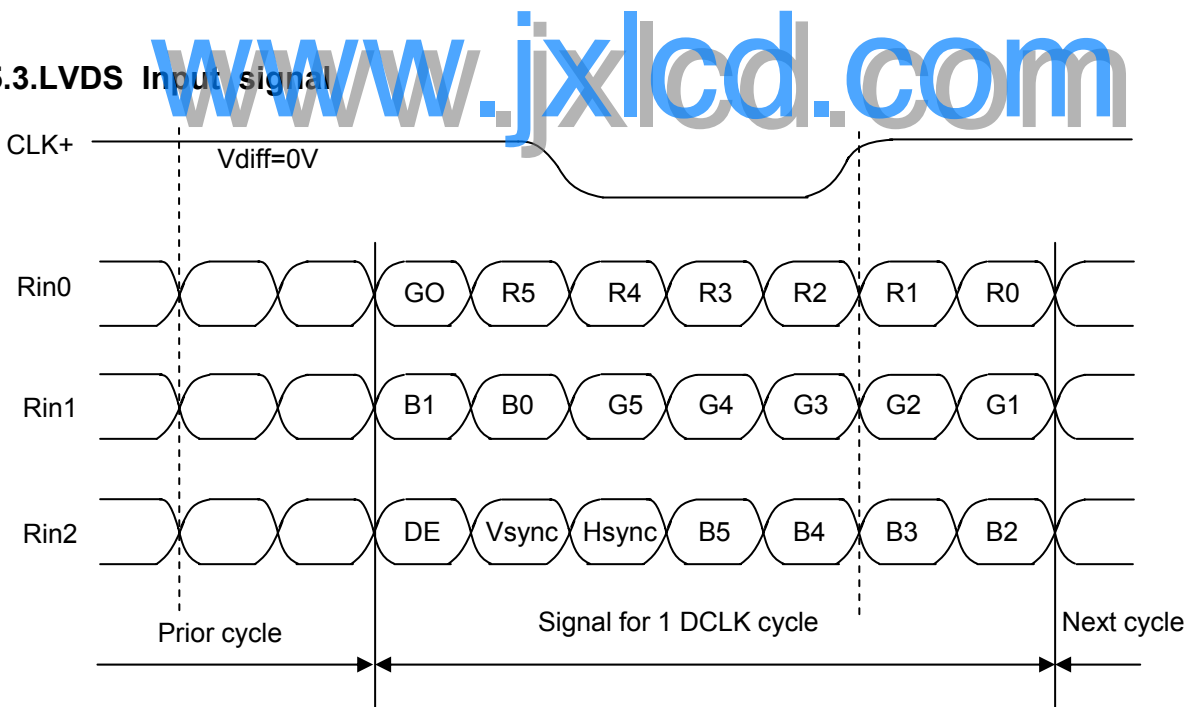
**5.3. LVDS Input signal**

Note. Pin connection in case of using Thine THC63LVDM63A

SPEC. NUMBER

SPEC TITLE

HT101WSB-100 Product Specification

PAGE

16 OF 35

S864-5046

B2006-5006-O (3/3)

A4(210 X 297)



### 5.3 Data Input Format

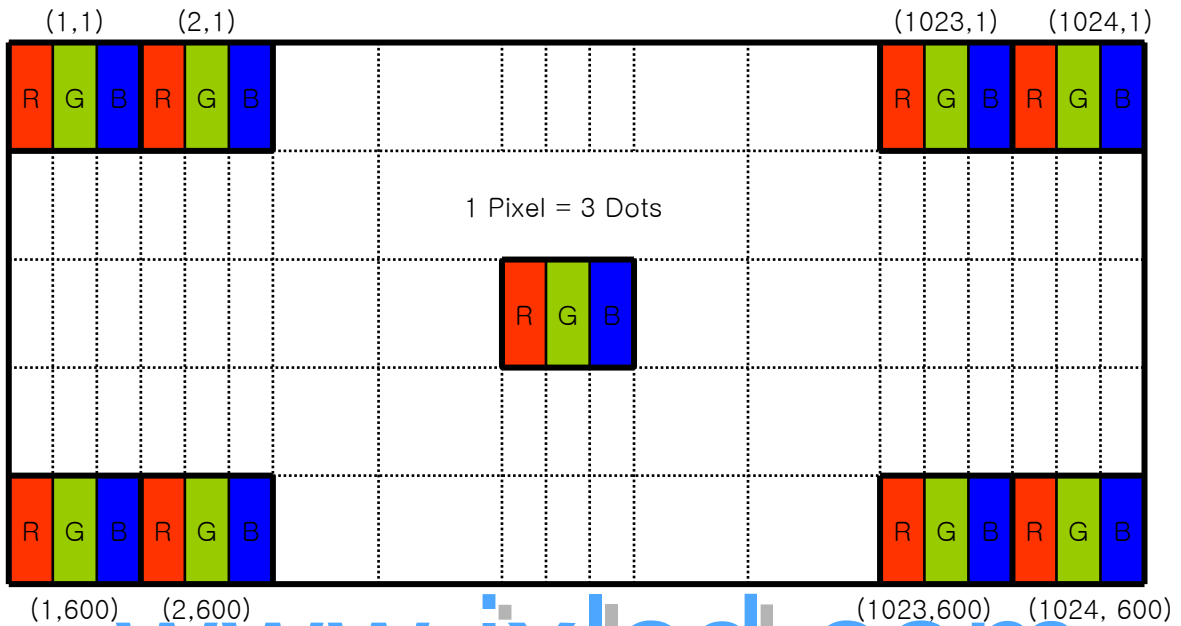

### 5.4 Back-light & LCM Interface Connection

Interface Connector: MS24022P10 or Equivalent

<Table 7. Pin Assignments for the BLU & LCM Connector>

Pin No.	Symbol	Description	Pin No.	Symbol	Description
1	Vout	LED anode connection	6	LED2	LED cathode connection
2	Vout	LED anode connection	7	LED3	LED cathode connection
3	Vout	LED anode connection	8	NC	No Connection
4	NC	No Connection	9	NC	No Connection
5	LED1	LED cathode connection	10	NC	No Connection

SPEC. NUMBER

SPEC TITLE

HT101WSB-100 Product Specification

PAGE

17 OF 35

S864-5046

B2006-5006-O (3/3)

A4(210 X 297)



# PRODUCT GROUP

REV

ISSUE DATE

TFT LCD PRODUCT

0

2009.5.31.

## 6.0 SIGNAL TIMING SPECIFICATION

6.1 The HT101WSB-100 is operated by the DE only.

Item		Symbols	Min	Typ	Max	Unit
Clock	Frequency	1/Tc	-	50.4	75	MHz
	High Time	Tch	-	4/7	-	Tc
	Low Time	Tcl	-	3/7	-	Tc
Frame Period		Tv	603	625	650	lines
			40	60	-	Hz
			-	16.7	25ms	ms
Vertical Display Period		Tvd	-	600	-	lines
One line Scanning Period		Th	1303	1344	1534	clocks
Horizontal Display Period		Thd	-	1024	-	clocks

SPEC. NUMBER

SPEC TITLE

HT101WSB-100 Product Specification

PAGE

18 OF 35

S864-5046

B2006-5006-O (3/3)

A4(210 X 297)

### 6.2 LVDS Rx Interface Timing Parameter

The specification of the LVDS Rx interface timing parameter is shown in Table 8.

<Table 8. LVDS Rx Interface Timing Specification>

Item	Symbol	Min	Typ	Max	Unit	Remark
CLKIN Period	tRCIP	11.76	13.26	20	nsec	
CLK Difference	tCdiff	-tRCIP*(3/7)	0	+tRCIP*(3/7)	nsec	
Input Data 0	tRIP1	-0.4	0.0	+0.4	nsec	
Input Data 1	tRIP0	tRCIP/7-0.4	tRCIP/7	tRCIP/7+0.4	nsec	
Input Data 2	tRIP6	2 × tRCIP/7-0.4	2 × tRCIP/7	2 × tRCIP/7+0.4	nsec	
Input Data 3	tRIP5	3 × tRCIP/7-0.4	3 × tRCIP/7	3 × tRCIP/7+0.4	nsec	
Input Data 4	tRIP4	4 × tRCIP/7-0.4	4 × tRCIP/7	4 × tRCIP/7+0.4	nsec	
Input Data 5	tRIP3	5 × tRCIP/7-0.4	5 × tRCIP/7	5 × tRCIP/7+0.4	nsec	
Input Data 6	tRIP2	6 × tRCIP/7-0.4	6 × tRCIP/7	6 × tRCIP/7+0.4	nsec	

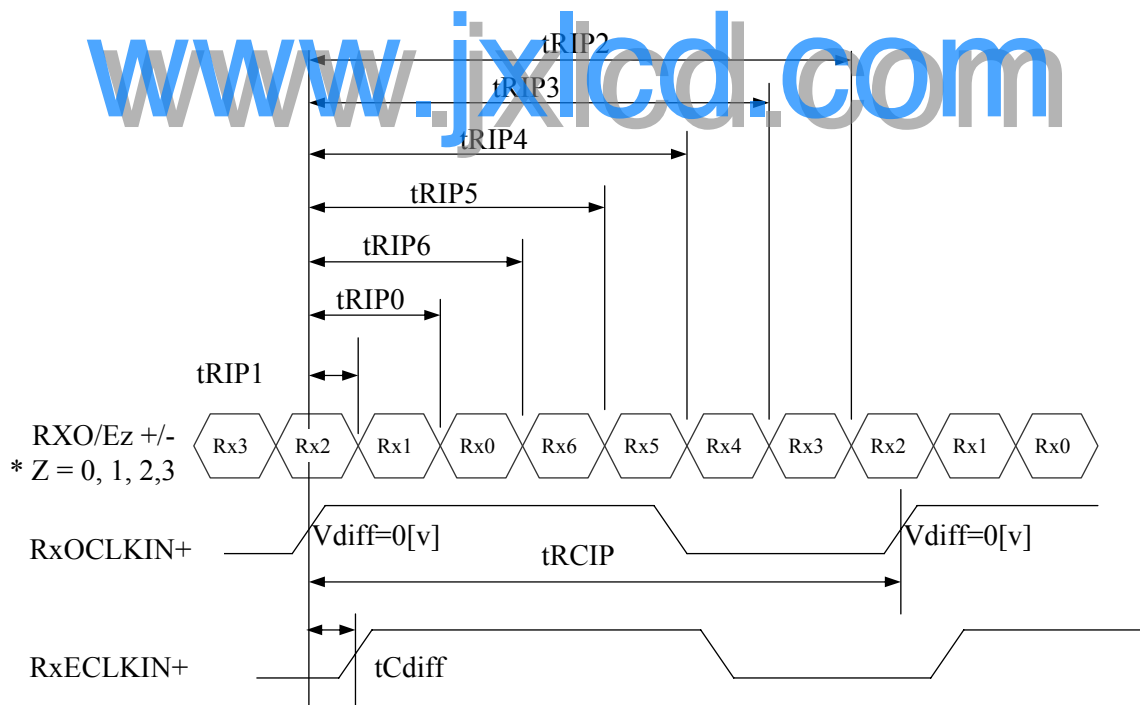

\* Vdiff = (RXO/Ez+) - (RXO/Ez-), ..., (RXO/ECLK+) - (RXO/ECLK-)

SPEC. NUMBER

SPEC TITLE

HT101WSB-100 Product Specification

PAGE

19 OF 35

S864-5046

B2006-5006-O (3/3)

A4(210 X 297)

## 7.0 SIGNAL TIMING WAVEFORMS OF INTERFACE SIGNAL

### 7.1 Sync Timing Waveforms

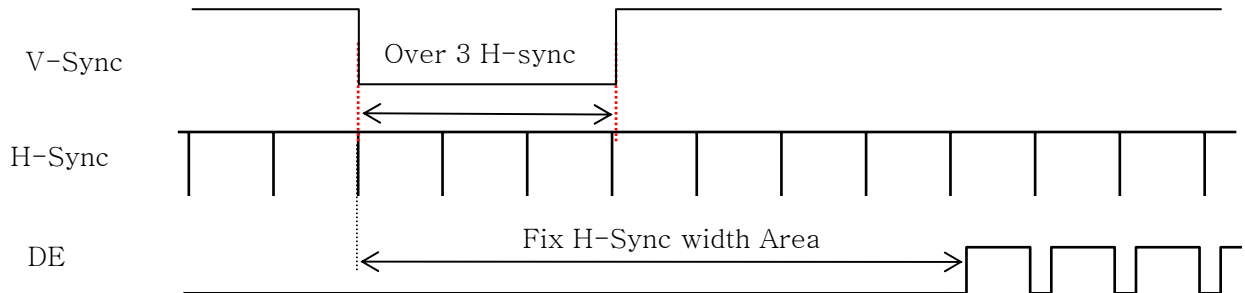

- 1) Need over 3 H-sync during V-Sync Low
- 2) Fix H-Sync width from V-Sync falling edge to first rising edge

### 7.2 Vertical Timing Waveforms

[www.jxlcd.com](http://www.jxlcd.com)

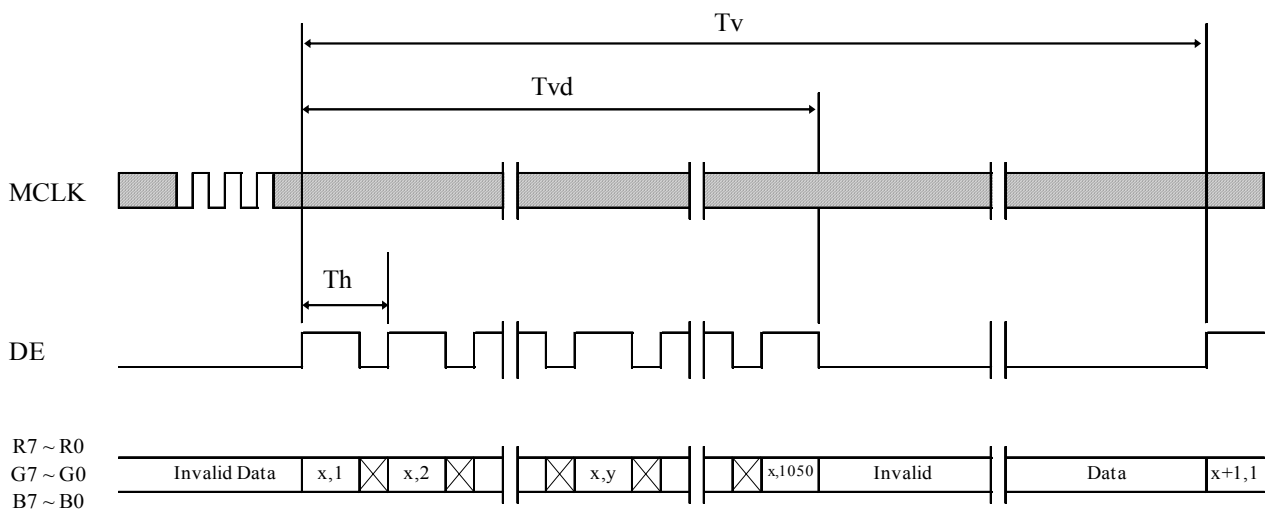

### 7.3 Horizontal Timing Waveforms

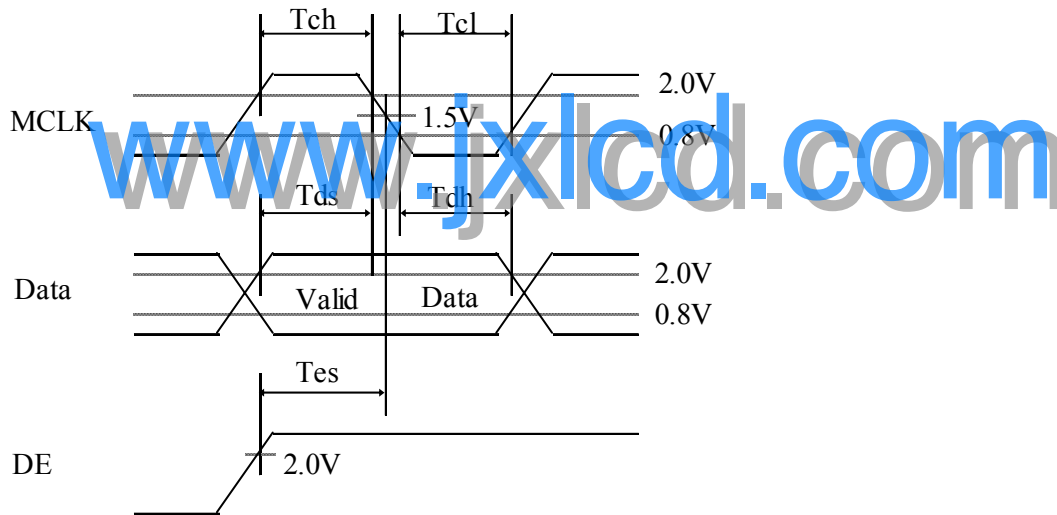
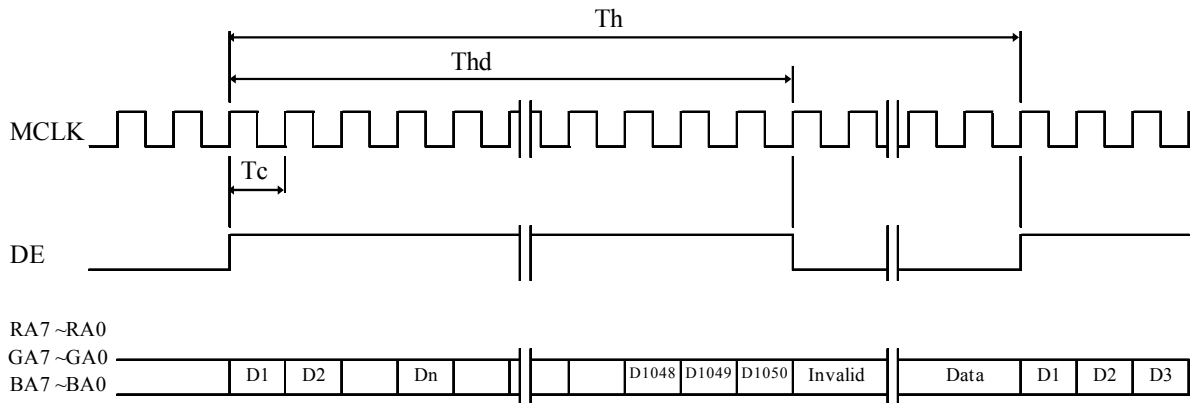



# PRODUCT GROUP

REV

ISSUE DATE

TFT LCD PRODUCT

0

2009.5.31.

## 8.0 INPUT SIGNALS, BASIC DISPLAY COLORS & GRAY SCALE OF COLORS

Color & Gray Scale		RED DATA								GREEN DATA								BLUE DATA							
		R7	R6	R5	R4	R3	R2	R1	R0	G7	G6	G5	G4	G3	G2	G1	G0	B7	B6	B5	B4	B3	B2	B1	B0
Basic Colors	Black	0	0	0	0	0	0	0	0	0	0	0	0	0	0	0	0	0	0	0	0	0	0	0	0
	Blue	0	0	0	0	0	0	0	0	0	0	0	0	0	0	0	0	1	1	1	1	1	1	1	1
	Green	0	0	0	0	0	0	0	0	1	1	1	1	1	1	1	1	0	0	0	0	0	0	0	0
	Cyan	0	0	0	0	0	0	0	0	1	1	1	1	1	1	1	1	1	1	1	1	1	1	1	1
	Red	1	1	1	1	1	1	1	1	0	0	0	0	0	0	0	0	0	0	0	0	0	0	0	0
	Magenta	1	1	1	1	1	1	1	1	0	0	0	0	0	0	0	0	1	1	1	1	1	1	1	1
	Yellow	1	1	1	1	1	1	1	1	1	1	1	1	1	1	1	1	0	0	0	0	0	0	0	0
	White	1	1	1	1	1	1	1	1	1	1	1	1	1	1	1	1	1	1	1	1	1	1	1	1
Gray Scale of RED	Black	0	0	0	0	0	0	0	0	0	0	0	0	0	0	0	0	0	0	0	0	0	0	0	0
	△	0	0	0	0	0	0	1	0	0	0	0	0	0	0	0	0	0	0	0	0	0	0	0	0
	Darker	0	0	0	0	0	0	1	0	0	0	0	0	0	0	0	0	0	0	0	0	0	0	0	0
	△	↑								↑								↑							
	▽	↓								↓								↓							
	Brighter	1	1	1	1	1	1	0	1	0	0	0	0	0	0	0	0	0	0	0	0	0	0	0	0
	▽	1	1	1	1	1	1	0	0	0	0	0	0	0	0	0	0	0	0	0	0	0	0	0	0
	Red	1	1	1	1	1	1	1	1	0	0	0	0	0	0	0	0	0	0	0	0	0	0	0	0
Gray Scale of GREEN	Black	0	0	0	0	0	0	0	0	0	0	0	0	0	0	0	0	0	0	0	0	0	0	0	0
	△	0	0	0	0	0	0	0	0	0	0	0	0	0	0	0	1	0	0	0	0	0	0	0	0
	Darker	0	0	0	0	0	0	0	0	0	0	0	0	0	0	1	0	0	0	0	0	0	0	0	0
	△	↑								↑								↑							
	▽	↓								↓								↓							
	Brighter	0	0	0	0	0	0	0	1	1	1	1	1	1	1	0	1	0	0	0	0	0	0	0	0
	▽	0	0	0	0	0	0	0	1	1	1	1	1	1	1	0	0	0	0	0	0	0	0	0	0
	Green	0	0	0	0	0	0	0	0	1	1	1	1	1	1	1	1	0	0	0	0	0	0	0	0
Gray Scale of BLUE	Black	0	0	0	0	0	0	0	0	0	0	0	0	0	0	0	0	0	0	0	0	0	0	0	0
	△	0	0	0	0	0	0	0	0	0	0	0	0	0	0	0	0	0	0	0	0	0	0	0	1
	Darker	0	0	0	0	0	0	0	0	0	0	0	0	0	0	0	0	0	0	0	0	0	0	0	1
	△	↑								↑								↑							
	▽	↓								↓								↓							
	Brighter	0	0	0	0	0	0	0	0	0	0	0	0	0	0	0	0	1	1	1	1	1	1	0	1
	▽	0	0	0	0	0	0	0	0	0	0	0	0	0	0	0	0	1	1	1	1	1	1	1	0
	Blue	0	0	0	0	0	0	0	0	0	0	0	0	0	0	0	0	1	1	1	1	1	1	1	1
Gray Scale of WHITE	Black	0	0	0	0	0	0	0	0	0	0	0	0	0	0	0	0	0	0	0	0	0	0	0	0
	△	0	0	0	0	0	0	1	0	0	0	0	0	0	0	0	1	0	0	0	0	0	0	0	1
	Darker	0	0	0	0	0	0	1	0	0	0	0	0	0	0	1	0	0	0	0	0	0	0	0	1
	△	↑								↑								↑							
	▽	↓								↓								↓							
	Brighter	1	1	1	1	1	1	0	1	1	1	1	1	1	1	0	1	1	1	1	1	1	1	0	1
	▽	1	1	1	1	1	1	0	0	1	1	1	1	1	1	0	0	1	1	1	1	1	1	1	0
	White	1	1	1	1	1	1	1	1	1	1	1	1	1	1	1	1	1	1	1	1	1	1	1	1

SPEC. NUMBER

SPEC TITLE

HT101WSB-100 Product Specification

PAGE

22 OF 35

S864-5046

B2006-5006-O (3/3)

A4(210 X 297)

## 9.0 POWER SEQUENCE

To prevent a latch-up or DC operation of the LCD module, the power on/off sequence shall be as shown in below

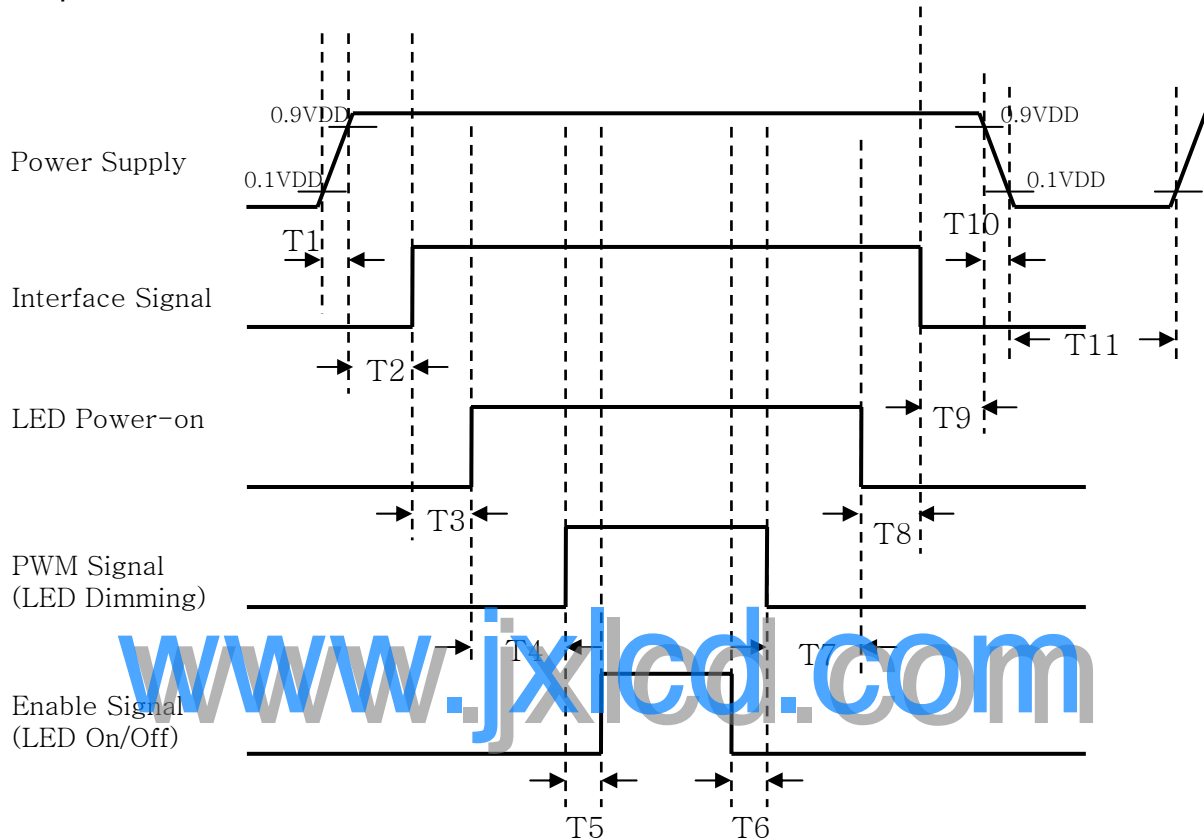

- $T1 \leq 10 \text{ ms}$
- $30 \text{ ms} \leq T2 \leq 50 \text{ ms}$
- $200 \text{ ms} \leq T3$
- $10 \text{ ms} \leq T4$
- $10 \text{ ms} \leq T5$
- $0 \text{ ms} \leq T6$
- $10 \text{ ms} \leq T7$
- $100 \text{ ms} \leq T8$
- $0 \text{ ms} \leq T9 \leq 50 \text{ ms}$
- $T10 \leq 10 \text{ ms}$
- $1 \text{ s} \leq T11$

### Notes:

1. When the power supply VDD is 0V, keep the level of input signals on the low or keep high impedance.
2. Do not keep the interface signal high impedance when power is on.
3. LED Back Light must be turn on after power for logic and interface signal are valid.

SPEC. NUMBER

S864-5046

SPEC TITLE

HT101WSB-100 Product Specification

PAGE

23 OF 35



# PRODUCT GROUP

REV

ISSUE DATE

TFT LCD PRODUCT

0

2009.5.31.

## 10.0 Connector Description

Physical interface is described as for the connector on LCM.

These connectors are capable of accommodating the following signals and will be following components.

### 10.1 TFT LCD Module

Connector Name /Description	For Signal Connector
Manufacturer	IPEX or Compatible
Type/ Part Number	I-PEX 20455-040E-12 or Compatible
Mating housing/ Part Number	I-PEX 20455-040T-11 or Compatible

[www.jxlcd.com](http://www.jxlcd.com)

SPEC. NUMBER

SPEC TITLE

HT101WSB-100 Product Specification

S864-5046

PAGE

24 OF 35

B2006-5006-O (3/3)

A4(210 X 297)





# PRODUCT GROUP

REV

ISSUE DATE

TFT LCD PRODUCT

0

2009.5.31.

## 11.0 MECHANICAL CHARACTERISTICS

### 11.1 Dimensional Requirements

FIGURE 6 shows mechanical outlines for the model HT101WSB-100. Other parameters are shown in Table 9.

<Table 9. Dimensional Parameters>

Parameter	Specification	Unit
Active Area	222.72 (H) × 125.28 (V)	mm
Number of pixels	1024 (H) X 600 (V) (1 pixel = R + G + B dots)	
Pixel pitch	0.2175 (H) X 0.2088 (V)	
Pixel arrangement	RGB Vertical stripe	
Display colors	262,144	
Display mode	Normally white	
Dimensional outline	235.5 × 143.5 × 5.2(max)	mm
Weight	190 (max)	gram
Back Light	Connector: MS24022P10	
	LED, Horizontal-LED Array type	

### 10.2 Mounting

See FIGURE 6.

### 10.3 Glare and Polarizer Hardness.

The surface of the LCD has an glare coating to maximize readability and hard coating to reduce scratching.

### 10.4 Light Leakage

There shall not be visible light from the back-lighting system around the edges of the screen as seen from a distance 50cm from the screen with an overhead light level of 350lux.

SPEC. NUMBER

SPEC TITLE

HT101WSB-100 Product Specification

PAGE

25 OF 35

S864-5046

B2006-5006-O (3/3)

A4(210 X 297)



# PRODUCT GROUP

REV

ISSUE DATE

TFT LCD PRODUCT

0

2009.5.31.

## 12.0 RELIABILITY TEST

The Reliability test items and its conditions are shown in below.

<Table 10. Reliability test>

No	Test Items	Conditions
1	High temperature storage test	Ta = 60 °C, 240 hrs
2	Low temperature storage test	Ta = -20 °C, 240 hrs
3	High temperature & high humidity operation test	Ta = 50 °C, 80%RH, 240 hrs
4	High temperature operation test	Ta = 50 °C, 240 hrs
5	Low temperature operation test	Ta = 0 °C, 240 hrs
6	Thermal shock	Ta = -20 °C ↔ 60 °C (0.5 hr), 100 cycle
7	Vibration test (non-operating)	1.5G, 10~500Hz Sign X,Y,Z / Sweep rate : 0.5hour
8	Shock test (non-operating)	220G, Half Sine Wave 2msec ±X, ±Y, ±Z Once for each direction
9	Electro-static discharge test (non-operating)	Air : 150 pF, 330Ω, 15 KV Contact : 150 pF, 330Ω, 8 KV

## 13.0 HANDLING & CAUTIONS

### (1) Cautions when taking out the module

- Pick the pouch only, when taking out module from a shipping package.

### (2) Cautions for handling the module

- As the electrostatic discharges may break the LCD module, handle the LCD module with care. Peel a protection sheet off from the LCD panel surface as slowly as possible.
- As the LCD panel and back - light element are made from fragile glass material, impulse and pressure to the LCD module should be avoided.
- As the surface of the polarizer is very soft and easily scratched, use a soft dry cloth without chemicals for cleaning.
- Do not pull the interface connector in or out while the LCD module is operating.
- Put the module display side down on a flat horizontal plane.
- Handle connectors and cables with care.

### (3) Cautions for the operation

- When the module is operating, do not lose CLK, ENAB signals. If any one of these signals is lost, the LCD panel would be damaged.
- Obey the supply voltage sequence. If wrong sequence is applied, the module

SPEC. NUMBER

SPEC TITLE

HT101WSB-100 Product Specification

PAGE

26 OF 35

S864-5046

B2006-5006-O (3/3)

A4(210 X 297)



## PRODUCT GROUP

REV

ISSUE DATE

TFT LCD PRODUCT

0

2009.5.31.

(4) Cautions for the atmosphere

- Dew drop atmosphere should be avoided.
- Do not store and/or operate the LCD module in a high temperature and/or humidity atmosphere. Storage in an electro-conductive polymer packing pouch and under relatively low temperature atmosphere is recommended.

(5) Cautions for the module characteristics

- Do not apply fixed pattern data signal to the LCD module at product aging.
- Applying fixed pattern for a long time may cause image sticking.

(6) Other cautions

- Do not disassemble and/or re-assemble LCD module.
- Do not re-adjust variable resistor or switch etc.
- When returning the module for repair or etc., Please pack the module not to be broken. We recommend to use the original shipping packages.

### 14.0 LABEL

(1) Product label



1      2      3      4      5      6      7

X	X	X	X	X	1	0	0	X	X	X	X	X	X	X
---	---	---	---	---	---	---	---	---	---	---	---	---	---	---

Type designation

No 5. Month (1, 2, 3, ..., 9, X, Y, Z)

No 1. Control Number

No 6. Product Identification (FG)

No 2. Rank / Grade

No 7. Serial Number

No 3. Line classification (BOE OT:A/BC)

No 4. Year (05 : 2005, 06: 2006, ...)

SPEC. NUMBER

SPEC TITLE

S864-5046

HT101WSB-100 Product Specification

PAGE

27 OF 35



# PRODUCT GROUP

REV

ISSUE DATE

TFT LCD PRODUCT

0

2009.5.31.

## (2) High voltage caution label

	<p>HIGH VOLTAGE CAUTION</p>	<p>COLD CATHODE FLUORESCENT LAMP IN LCD PANEL CONTAINS A SMALL AMOUNT OF MERCURY. PLEASE FOLLOW LOCAL OR- DINANCES OR REGULATIONS FOR DISPOSAL.</p>
	<p>RISK OF ELECTRIC SHOCK, DISCONNECT THE ELECTRIC POWER BEFORE SERVICING</p>	

## (3) Box label

Label Size: 110 mm (L) × 56 mm (W)

Contents

Model: HT101WSB-100

Q`ty: Module Q`ty in one box

Serial No.: Box Serial No. See next figure for detail description.

Date: Packing Date

Internal use of Product

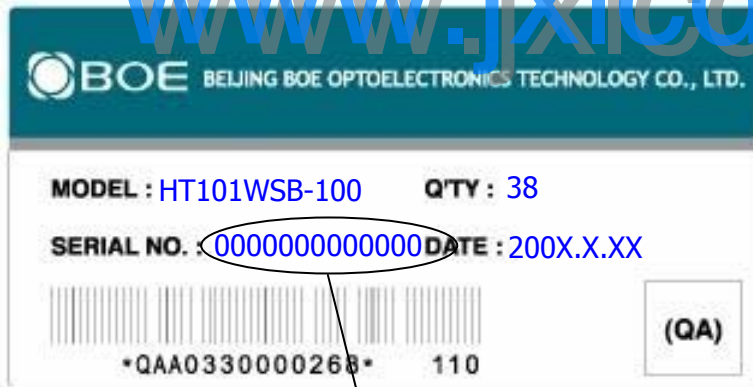

00	0	0	00	0	0000	000000
Type	Grade	Line	Year	Month	Internal use	Serial No

SPEC. NUMBER

SPEC TITLE

HT101WSB-100 Product Specification

PAGE

28 OF 35

S864-5046

B2006-5006-O (3/3)

A4(210 X 297)

## 15.0 PACKING INFORMATION

### 15.1 Packing Order

Put the paper pad in the box



After the box filled with the modules, Put the EPE on the top of modules



After sealing the box, attach packing label on the attach position sign area of the box

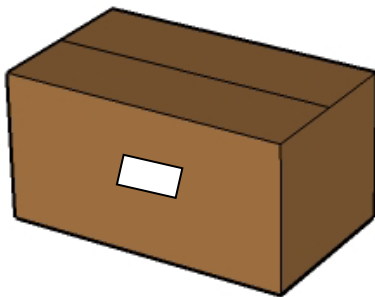

Put the paper cover on the top of EPE

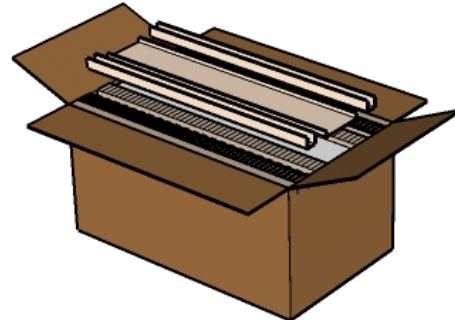

### 15.2 Notes

- Box Dimension: 282mm(W) × 482mm(L) × 249mm(H)
- Package Quantity in one Box: 38 pcs
- Total Weight: 9.1kg

SPEC. NUMBER

SPEC TITLE

HT101WSB-100 Product Specification

PAGE

29 OF 35

S864-5046

B2006-5006-O (3/3)

A4(210 X 297)

**16.0 MECHANICAL OUTLINE DIMENSION**

Figure 6. TFT-LCD Module Outline Dimension (Front View)

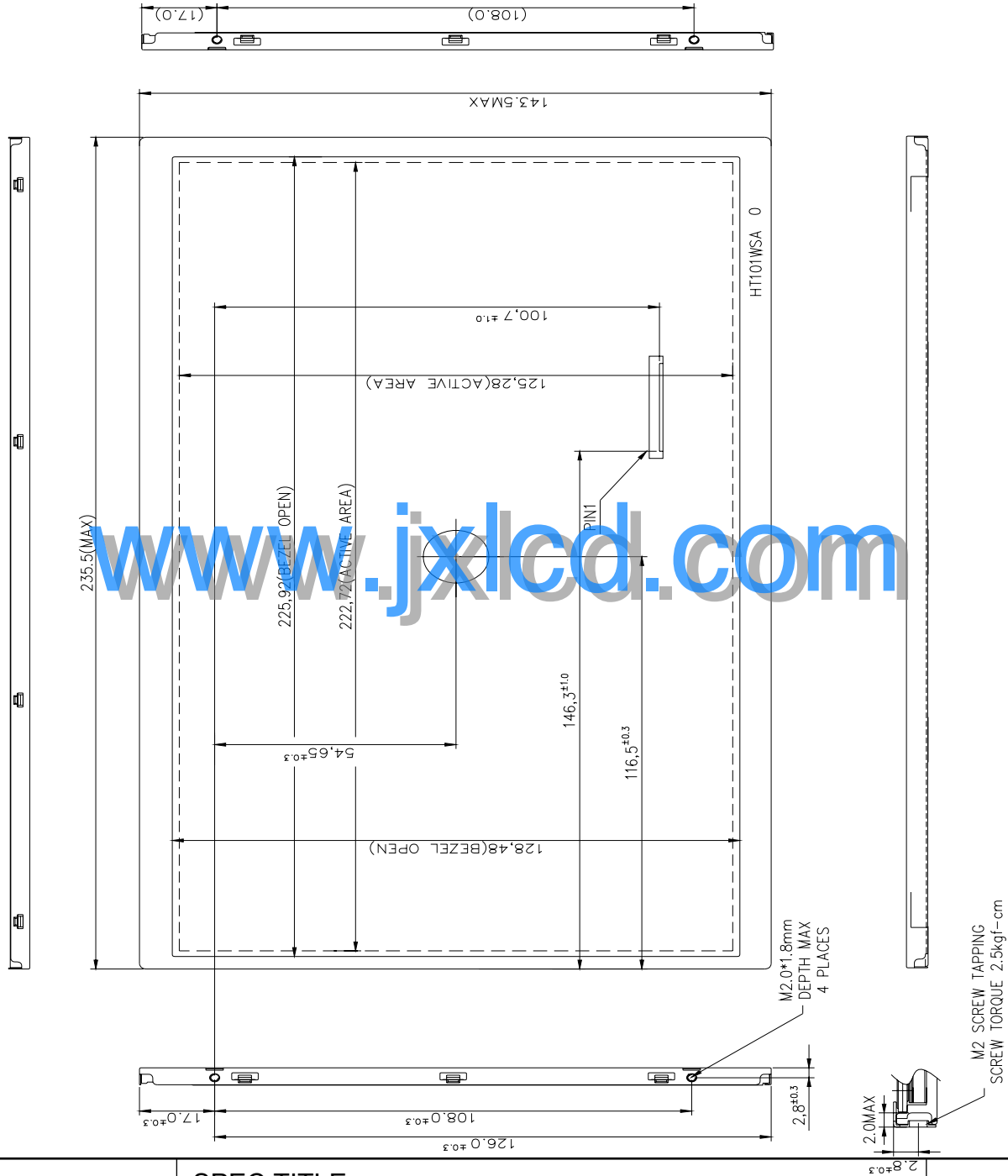

SPEC. NUMBER

SPEC TITLE

PAGE

S864-5046

HT101WSB-100 Product Specification

30 OF 35

B2006-5006-O (3/3)

A4(210 X 297)

Figure 7. TFT-LCD Module Outline Dimensions (Rear view)





# PRODUCT GROUP

REV

ISSUE DATE

TFT LCD PRODUCT

0

2009.5.31.

## 17.0 EDID Table

Address (HEX)	Function	Hex	Dec	values.	Notes
00	Header	00	0	0	EDID Header
01		FF	255	255	
02		FF	255	255	
03		FF	255	255	
04		FF	255	255	
05		FF	255	255	
06		FF	255	255	
07		00	0	0	
08	ID Manufacturer Name	09	9	BOE	ID = BOE
09		E5	229		
0A	ID Product Code	85	133	1413	ID = 0585
0B		05	5		
0C	32-bit serial No.	00	0		
0D		00	0		
0E		00	0		
0F		00	0		
10	Week of manufacture	01	1	1	
11	Year of Manufacture	13	19	2009	Manufactured in 2009
12	EDID Structure Ver.	01	1	1	EDID Ver 1.0
13	EDID revision #	03	3	3	EDID Rev. 0.3
14	Video input definition	80	128	-	
15	Max H image size	16	22	22	22 cm (Approx)
16	Max V image size	0D	13	13	13 cm (Approx)
17	Display Gamma	78	120	2.2	Gamma curve = 2.2
18	Feature support	0A	10		RGB display, Preferred Timming mode
19	Red/Green low bits	22	34	-	Red / Green Low Bits
1A	Blue/White low bits	C0	192	-	Blue / White Low Bits
1B	Red x high bits	95	149	0.583	Red (x) = 10010101 (0.58348)
1C	Red y high bits	56	86	0.338	Red (y) = 01010110 (0.33836)
1D	Green x high bits	4E	78	0.305	Green (x) = 01001110 (0.30482)
1E	Green y high bits	8E	142	0.557	Green (y) = 10001110 (0.55656)
1F	Blue x high bits	26	38	0.148	Blue (x) = 00100110 (0.14812)
20	Blue y high bits	24	36	0.141	Blue (y) = 00100100 (0.14068)
21	White x high bits	50	80	0.313	White (x) = 01010000 (0.313)
22	White y high bits	54	84	0.329	White (y) = 01010100 (0.329)

SPEC. NUMBER

SPEC TITLE

HT101WSB-100 Product Specification

PAGE

32 OF 35

S864-5046

B2006-5006-O (3/3)

A4(210 X 297)





# PRODUCT GROUP

REV

ISSUE DATE

TFT LCD PRODUCT

0

2009.5.31.

Address (HEX)	Function	Hex	Dec	values.	Notes
23	Established timing 1	00	0	-	
24	Established timing 2	00	0	-	
25	Established timing 3	00	0	-	
26	Standard timing #1	01	1		Not Used
27		01	1		
28	Standard timing #2	01	1		Not Used
29		01	1		
2A	Standard timing #3	01	1		Not Used
2B		01	1		
2C	Standard timing #4	01	1		Not Used
2D		01	1		
2E	Standard timing #5	01	1		Not Used
2F		01	1		
30	Standard timing #6	01	1		Not Used
31		01	1		
32	Standard timing #7	01	1		Not Used
33		01	1		
34	Standard timing #8	01	1		Not Used
35		01	1		
36	Detailed timing/monitor descriptor #1 (60Hz)	B0	176	50.40	50.4MHz Main clock
37		13	19		
38		00	0	1024	Hor Active = 1024
39		40	64	320	Hor Blanking = 320
3A		41	65	-	4 bits of Hor. Active + 4 bits of Hor. Blanking
3B		58	88	600	Ver Active = 600
3C		19	25	25	Ver Blanking = 25
3D		20	32	-	4 bits of Ver. Active + 4 bits of Ver. Blanking
3E		30	48	48	Hor Sync Offset = 48
3F		20	32	32	H Sync Pulse Width = 32
40		45	69	4	V sync Offset = 4 line
41		00	0	5	V Sync Pulse width : 5 line
42		DF	223	223	Horizontal Image Size = 223 mm (Low 8 bits)
43		7D	125	125	Vertical Image Size = 125 mm (Low 8 bits)
44		00	0	-	4 bits of Hor Image Size + 4 bits of Ver Image Size
45		00	0	0	Hor Border (pixels)
46	00	0	0	Vertical Border (Lines)	
47	19	25	-		

SPEC. NUMBER

SPEC TITLE

HT101WSB-100 Product Specification

PAGE

33 OF 35

S864-5046

B2006-5006-O (3/3)

A4(210 X 297)



# PRODUCT GROUP

REV

ISSUE DATE

TFT LCD PRODUCT

0

2009.5.31.

Address (HEX)	Function	Hex	Dec	values.	Notes
48	Detailed timing/monitor descriptor #2	00	0		
49		00	0		
4A		00	0		
4B		0F	15		
4C		00	0		
4D		0A	10		
4E		00	0		
4F		00	0		
50		00	0		
51		00	0		
52		00	0		
53		00	0		
54		00	0		
55		00	0		
56		00	0		
57		00	0		
58		00	0		
59		20	32		
5A		Detailed timing/monitor descriptor #3	00	0	
5B	00		0		
5C	00		0		
5D	FE		254		
5E	00		0		
5F	42		66	B	Manufacturer name : BOE OT
60	4F		79	O	
61	45		69	E	
62	20		32		
63	4F		79	O	
64	54		84	T	
65	0A		10		
66	20		32		
67	20		32		
68	20	32			
69	20	32			
6A	20	32			
6B	20	32			

www.jxlcd.com

SPEC. NUMBER

SPEC TITLE

HT101WSB-100 Product Specification

PAGE

34 OF 35

S864-5046

B2006-5006-O (3/3)

A4(210 X 297)



# PRODUCT GROUP

REV

ISSUE DATE

TFT LCD PRODUCT

0

2009.5.31.

Address (HEX)	Function	Hex	Dec	values.	Notes
6C	Detailed timing/monitor descriptor #4	00	0		Product Name Tag (ASCII)
6D		00	0		
6E		00	0		
6F		FE	254		
70		00	0		Model name : HT101WSB-100
71		48	72	H	
72		54	84	T	
73		31	49	1	
74		30	48	0	
75		31	49	1	
76		57	87	W	
77		53	83	S	
78		42	66	B	
79		2D	45	-	
7A		<b>31</b>	<b>49</b>	<b>1</b>	
7B		30	48	0	
7C	<b>30</b>	<b>48</b>	<b>0</b>		
7D	0A	10			
7E	Extension flag	00	0		
7F	Checksum	<b>51</b>	<b>81</b>		

[www.jxlcd.com](http://www.jxlcd.com)

SPEC. NUMBER

SPEC TITLE

HT101WSB-100 Product Specification

PAGE

35 OF 35

S864-5046

B2006-5006-O (3/3)

A4(210 X 297)