



**PROPRIETARY NOTE**

THIS SPECIFICATION IS THE PROPERTY OF BOE-HYDIS AND SHALL NOT BE REPRODUCED OR COPIED WITHOUT THE WRITTEN PERMISSION OF BOE-HYDIS AND MUST BE RETURNED TO BOE-HYDIS UPON ITS REQUEST.

**TITLE : HT10X21-100 Product Specification**

**Rev. 0**

**BOE-HYDIS Technology Co., Ltd**

SPEC. NUMBER	PRODUCT GROUP	REV.	ISSUE DATE	PAGE
S864-1132	TFT-LCD PRODUCT	0	2003.01.30	1 OF 22



PRODUCT GROUP

REV.

ISSUE DATE

TFT-LCD PRODUCT

0

2003. 01. 30

REVISION HISTORY

REV.	ECN NO.	DESCRIPTION OF CHANGES	DATE	PREPARED
0		Initial Release	03.01.30.	S. Y. Kim

SPEC. NUMBER  
S864-1132

SPEC. TITLE  
HT10X21-100 Product Specification

PAGE  
2 OF 22



**PRODUCT GROUP**

**REV.**

**ISSUE DATE**

TFT-LCD PRODUCT

0

2003. 01. 30

## Contents

No	Item	Page
1.0	General Description	4
2.0	Absolute Maximum Ratings	5
3.0	Electrical Specifications	6
4.0	Optical Specifications	7
5.0	Interface Connection	9
6.0	Signal Timing Specifications	11
7.0	Signal Timing Waveforms of interface signal (DE mode)	13
8.0	Input Signals, Display Colors & Gray Scale of Colors	14
9.0	Power Sequence	15
10.0	Mechanical Characteristics	16
11.0	Reliability Test	17
12.0	Handling & Cautions	18
13.0	Appendix	19

SPEC. NUMBER  
S864-1132

SPEC. TITLE  
HT10X21-100 Product Specification

PAGE  
3 OF 22



**PRODUCT GROUP**

REV.

ISSUE DATE

TFT-LCD PRODUCT

0

2003.01.30

**1.0 GENERAL DESCRIPTION**

1.1 Introduction

HT10X21-100 is a color active matrix TFT LCD module using amorphous silicon TFT's (Thin Film Transistors) as active switching devices. This module has a 10.4 inch diagonally measured active area with XGA resolutions (1024 horizontal by 768 vertical pixel array). Each pixel is divided into RED, GREEN, BLUE dots which are arranged in vertical stripe and this module can display 262,144 colors. The TFT-LCD panel used for this module is a low reflection and higher

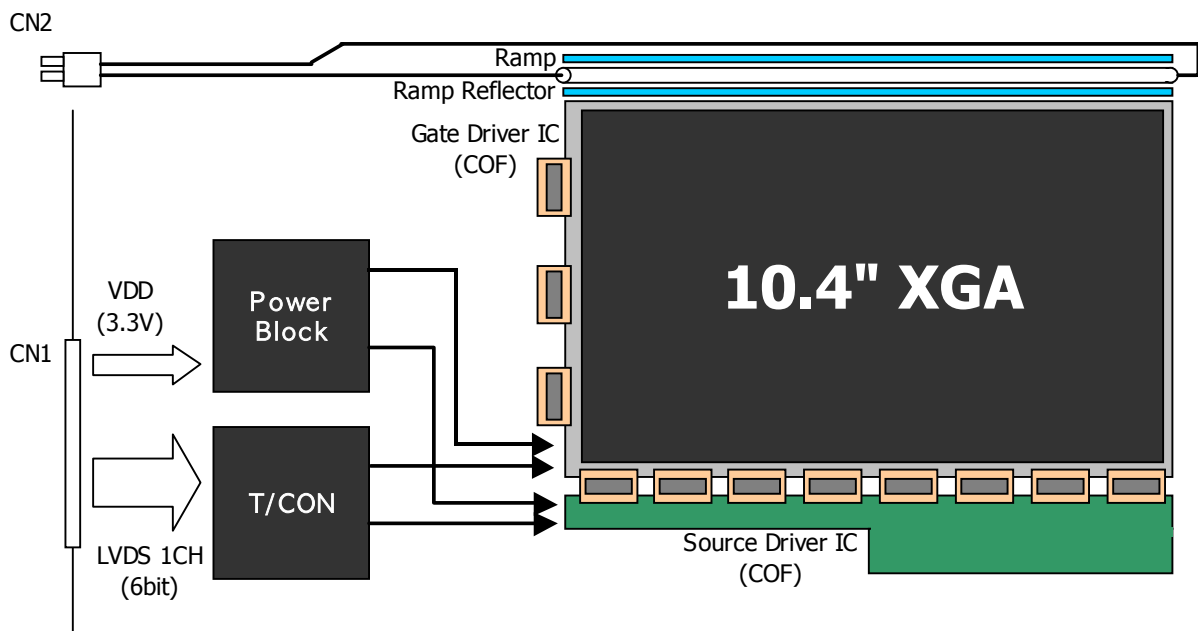

1.2 Features

- LVDS Interface with 1pixel / clock
- High-speed response
- 6-bit color depth, Display 262,144 colors
- Incorporated edge type back-light (1 lamp)
- High luminance and contrast ratio, low reflection and wide viewing angle
- DE (Data Enable) mode only

1.3 Applications

- Pentype & Tablet PC

SPEC. NUMBER  
S864-1132

SPEC. TITLE  
HT10X21-100 Product Specification

PAGE  
4 OF 22



**PRODUCT GROUP**

REV.

ISSUE DATE

TFT-LCD PRODUCT

0

2003.01.30

1.4 General Specifications

Parameter	Specification	Unit	Remark
Active area	210.432 X 157.824	mm	
Number of pixels	1024(H) × 768(V)	pixels	
Pixel pitch	0.2055(H) × 0.2055(V)	mm	
Pixel arrangement	RGB Vertical stripe		
Display colors	262,144	colors	
Display mode	Normally Black		
Dimensional outline	238.6(H) X 173.2(V) X 5.0max	mm	Note 2
Weight	235 typ.	gram	
Back-light	Top edge side 1-CCFL type		Note 1
Surface treatment	Haze 25, Anti-glare & hard-coating (3H)		

Note: 1. CCFL (Cold Cathode Fluorescent Lamp)

2. LCM Height: 5.0[mm]Max(Lamp) , 6.8[mm]Max(Component)

**2.0 ABSOLUTE MAXIMUM RATINGS**

The followings are maximum values which, if exceed, may cause faulty operation or damage to the unit.

[VSS = GND = 0V]

Parameter	Symbol	Min	Max	Unit	Remark
Power Input Voltage	V <sub>DD</sub>	VSS-0.3	4.0	V	Ta = 25°C
Logic Input Voltage	V <sub>IN</sub>	VSS-0.3	V <sub>DD</sub> +0.3	V	
Back-light Lamp Current	I <sub>BL</sub>	3	7	mA	
Back-light lamp Frequency	F <sub>L</sub>	40	80	KHz	
Operating Temperature (Humidity)	T <sub>OP</sub>	0	+50	°C	≤ 40 °C
	RH		80	%	
Storage Temperature (Humidity)	T <sub>ST</sub>	-20	+60	°C	≤ 40 °C
	RH		90	%	

SPEC. NUMBER  
S864-1132

SPEC. TITLE  
HT10X21-100 Product Specification

PAGE  
5 OF 22



**PRODUCT GROUP**

REV.

ISSUE DATE

TFT-LCD PRODUCT

0

2003. 01. 30

**3.0 ELECTRICAL SPECIFICATIONS**

[Ta = 25 ±2°C ]

Parameter		Min	Typ	Max	Unit	Remark
Power Supply Voltage	V <sub>DD</sub>	3.0	3.3	3.6	V	
Power Supply Current	I <sub>DD</sub>	-	210		mA	Note1
Permissible Input Ripple Voltage	V <sub>RF</sub>	-	-	100	mV	V <sub>DD</sub> = 3.3V
High Level Differential Input Threshold Voltage	V <sub>IH</sub>	-	-	+100	mV	V <sub>cm</sub> = 1.2V typ.
Low Level Differential Input Threshold Voltage	V <sub>IL</sub>	-100	-	-	mV	
Back-light Lamp Voltage	V <sub>BL</sub>	-	520	-	V <sub>rms</sub>	
Back-light Lamp Current	I <sub>BL</sub>	3.0	5.0	6.0	mA <sub>rm</sub>	
Back-light Lamp Frequency	F <sub>L</sub>	40	60	80	KHz	Note 2
Lamp Start Voltage				950	V <sub>rms</sub>	25°C , Note 3
				1150	V <sub>rms</sub>	0°C , Note 3
Lamp Life		10,000			hrs	I <sub>BL</sub> = 3.0~6.0mA
Power Consumption		P <sub>D</sub>	0.7		W	
		P <sub>BL</sub>	2.6		W	I <sub>BL</sub> = 5.0mA, Note 4
		P <sub>total</sub>	3.3		W	

Notes:

- The supply voltage is measured and specified at the interface connector of LCM.  
The current draw and power consumption specified is for VDD = 3.3V, Frame rate = 60 Hz and Clock frequency = 65MHz.  
Test Pattern of power supply current  
a) Typ : Vertical color bar pattern  
b) Max : Gray 28 @ Vertical 2 Skip line pattern
- The lamp frequency should be selected as different as possible from the horizontal synchronous frequency and its harmonics to avoid interference, which may cause line flow on the display
- The voltage above this value should be applied to the lamps for more than 1 second to startup. Otherwise the lamps may not to be turned on.
- Calculated value for reference (V<sub>BL</sub> × I<sub>BL</sub>) excluding inverter loss.

SPEC. NUMBER  
S864-1132

SPEC. TITLE  
HT10X21-100 Product Specification

PAGE  
6 OF 22



**PRODUCT GROUP**

REV.

ISSUE DATE

TFT-LCD PRODUCT

0

2003.01.30

**4.0 OPTICAL SPECIFICATIONS**

The measurement shall be executed after 30 minutes warm-up period.

Measuring equipment: TOPCON-BM5.

[VDD=3.3V, Frame rate=60Hz, Clock=65MHz, I<sub>BL</sub> = 5.0mA, Ta = 25 ±2°C ]

Parameter		Symbol	Condition	Min	Typ	Max	Unit	Remark
Viewing Angle	Horizontal	$\theta_3$	CR > 10		80		Deg	Note 1
		$\theta_9$			80		Deg	
	Vertical	$\theta_{12}$			80	-	Deg	
		$\theta_6$			80	-	Deg	
Luminance contrast ratio		CR		-	450	-		Note 2
Luminance of white		Y <sub>L</sub>		TBD	150	-	cd/m <sup>2</sup>	Note 3
White luminance uniformity		$\Delta Y$		-	-	1.4		Note 4
Color Cord.	White	x <sub>w</sub>	$\theta = 0^\circ$ (Center) Normal Viewing Angle	0.288	0.318	0.348		Note 5
		y <sub>w</sub>		0.313	0.343	0.373		
	Red	x <sub>R</sub>		0.553	0.583	0.613		
		y <sub>R</sub>		0.307	0.337	0.367		
	Green	x <sub>G</sub>		0.280	0.310	0.340		
		y <sub>G</sub>		0.518	0.548	0.578		
	Blue	x <sub>B</sub>		0.120	0.150	0.180		
		y <sub>B</sub>		0.118	0.148	0.178		
Color Reproduction					45		%	
Response time	T <sub>total</sub> (Tr + Td)	T <sub>total</sub>		-	40	45	msec	Note 6
Cross talk		CT		-	-	2.0	%	Note 7

SPEC. NUMBER  
S864-1132

SPEC. TITLE  
HT10X21-100 Product Specification

PAGE  
7 OF 22



**PRODUCT GROUP**

REV.

ISSUE DATE

TFT-LCD PRODUCT

0

2003.01.30

Note:

1. Viewing angle is the angle at which the contrast ratio is greater than 10. The viewing are determined for the horizontal or 3, 9 o'clock direction and the vertical or 6, 12 o'clock direction with respect to the optical axis which is normal to the LCD surface (see FIGURE 1 shown in Appendix).
2. Contrast measurements shall be made at viewing angle of  $\theta = 0^\circ$  and at the center of the LCD surface. Luminance shall be measured with all pixels in the view field set first to white, then to the dark (black) state. (See FIGURE 1 shown in Appendix) Luminance Contrast Ratio (CR) is defined mathematically.

$$CR = \frac{\text{Luminance when displaying a white raster}}{\text{Luminance when displaying a black raster}}$$

3. Luminance of white is defined as a center point(#1) on LCD surface. Luminance shall be measured with all pixels in the view field set first to white. This measurement shall be taken at the locations shown in FIGURE 2 for a total of the measurements per display.
4. The White luminance uniformity on LCD surface is then expressed as :  $\Delta Y = \text{Maximum Luminance of 5 points} / \text{Minimum Luminance of 5 points}$  (see FIGURE 2 shown in Appendix).
5. The color chromaticity coordinates specified in Table 4 shall be calculated from the spectral data measured with all pixels first in red, green, blue and white. Measurements shall be made at the center of the panel.
6. The electro-optical response time measurements shall be made as FIGURE 3 shown in Appendix by switching the "data" input signal ON and OFF. The times needed for the luminance to change from 10% to 90% is Tr, and 90% to 10% is Td.
7. Cross-Talk of one area of the LCD surface by another shall be measured by comparing the luminance ( $Y_A$ ) of a 25mm diameter area, with all display pixels set to a gray level, to the luminance ( $Y_B$ ) of that same area when any adjacent area is driven dark. (See FIGURE 4 shown in Appendix).

SPEC. NUMBER  
S864-1132

SPEC. TITLE  
HT10X21-100 Product Specification

PAGE  
8 OF 22





**PRODUCT GROUP**

REV.

ISSUE DATE

TFT-LCD PRODUCT

0

2003.01.30

**5.0 INTERFACE CONNECTION**

5.1 Electrical Interface

CN1            Interface connector            : DF19L-14P-1H (HIROSE) or equivalent  
                   User side connector            : DF19G-14S-1C (HIROSE) or equivalent

Pin No	Symbol	Function	Remark
1	VDD1	Power Supply: +3.3V	
2	VDD2	Power Supply: +3.3V	
3	VSS	Ground	
4	VSS	Ground	
5	RIN0-	LVDS Negative data signal (-)	Tx pin # 48
6	RIN0+	LVDS Positive data signal (+)	Tx pin # 47
7	RIN1-	LVDS Negative data signal (-)	Tx pin # 46
8	RIN1+	LVDS Positive data signal (+)	Tx pin # 45
9	RIN2-	LVDS Negative data signal (-)	Tx pin # 42
10	RIN2+	LVDS Positive data signal (+)	Tx pin # 41
11	RCLKIN-	LVDS Negative clock signal (-)	Tx pin # 40
12	RCLKIN+	LVDS Positive clock signal (+)	Tx pin # 39
13	VSS	Ground	
14	VSS	Ground	

5.2 Back-light Interface

CN2            Connector                                : HV-2S-C1 (JAE) or equivalent  
                   User side connector                : HV-2P-HF (JAE) or equivalent

Pin No	INPUT	Function
1	HOT	High Voltage
2	COLD	Ground

SPEC. NUMBER  
S864-1132

SPEC. TITLE  
HT10X21-100 Product Specification

PAGE  
9 OF 22



**PRODUCT GROUP**

REV.

ISSUE DATE

TFT-LCD PRODUCT

0

2003.01.30

5.3 LVDS Interface

LVDS Transmitter: THC63LVDM83A or equivalent.

Input signal	Transmitter		Interface		DF19L-14P-1H	Remark
	Pin No	Pin No	System (Tx)	TFT-LCD (Rx)	Pin No.	
R0	51	48 47	OUT0- OUT0+	IN0- IN0+	5	
R1	52					
R2	54					
R3	55					
R4	56				6	
R5	3					
G0	4	46 45	OUT1- OUT1+	IN1- IN1+	7	
G1	6					
G2	7					
G3	11					
G4	12				8	
G5	14					
B0	15	42 41	OUT2- OUT2+	IN2- IN2+	9	
B1	19					
B2	20					
B3	22					
B4	23				10	
B5	24					
HSYNC	27	30	CLKOUT- CLKOUT+	CLKIN- CLKIN+	11	
VSYNC	28					
DE	30					
MCLK	31	40 39			12	

SPEC. NUMBER  
S864-1132

SPEC. TITLE  
HT10X21-100 Product Specification

PAGE  
10 OF 22



**PRODUCT GROUP**

REV.

ISSUE DATE

TFT-LCD PRODUCT

0

2003.01.30

**5.4 Data Input Format**

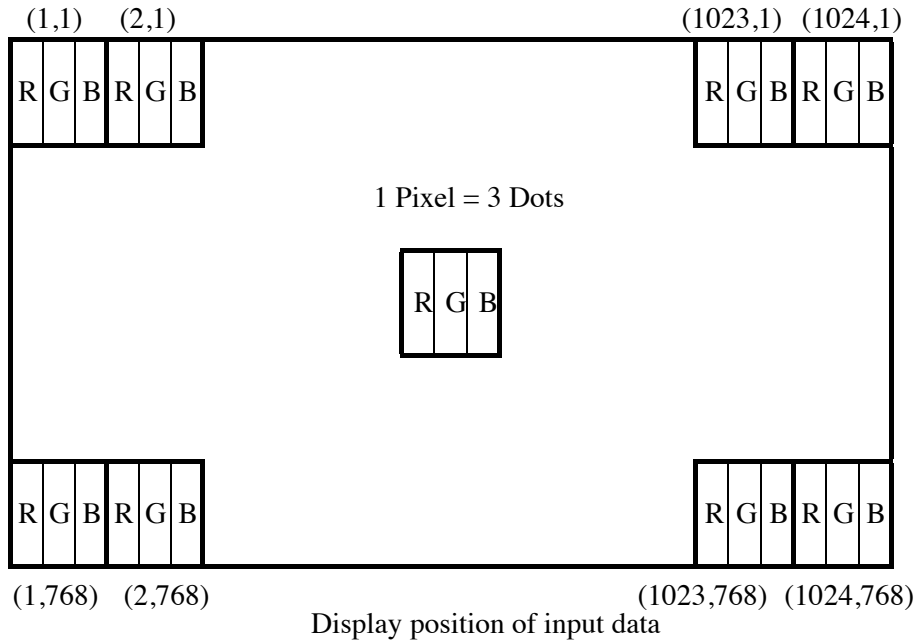

**6.0 SIGNAL TIMING SPECIFICATIONS**

6.1 The HT10X21-100 is operated by the only DE (Data enable) mode (LVDS Transmitter Input)

Item	Symbols	Min	Typ	Max	Unit	
Clock	Frequency	1/Tc	-	65	80	MHz
	High Time	Tch	4.5	-	-	ns
	Low Time	Tcl	4.5	-	-	ns
Data	Setup Time	Tds	2.7	-	-	ns
	Hold Time	Tdh	0	-	-	ns
Data Enable Setup Time	Tes	2.7	-	-	ns	
Frame Period	Tv	772	806	1022	lines	
Vertical Display Period	Tvd	768	768	768	lines	
One Line Scanning Period	Th	1100	1344	2046	clocks	
Horizontal Display Period	Thd	1024	1024	1024	clocks	

SPEC. NUMBER  
S864-1132

SPEC. TITLE  
HT10X21-100 Product Specification

PAGE  
11 OF 22



**PRODUCT GROUP**

REV.

ISSUE DATE

TFT-LCD PRODUCT

0

2003.01.30

6.2 LVDS Rx interface timing parameter

The specification of the LVDS Rx interface timing parameter

<LVDS Rx Interface Timing Specification>

Item	Symbol	Min	Typ	Max	Unit	Remark
CLKIN Period	tRCIP	12.5	15.38	-	nsec	
Input Data 0	tRIP1	-0.4	0.0	+0.4	nsec	
Input Data 1	tRIP0	1*tRCIP/7 -0.4	1*tRCIP/7	1*tRCIP/7 +0.4	nsec	
Input Data 2	tRIP6	2*tRCIP/7 -0.4	2*tRCIP/7	2*tRCIP/7 +0.4	nsec	
Input Data 3	tRIP5	3*tRCIP/7 -0.4	3*tRCIP/7	3*tRCIP/7 +0.4	nsec	
Input Data 4	tRIP4	4*tRCIP/7 -0.4	4*tRCIP/7	4*tRCIP/7 +0.4	nsec	
Input Data 5	tRIP3	5*tRCIP/7 -0.4	5*tRCIP/7	5*tRCIP/7 +0.4	nsec	
Input Data 6	tRIP2	6*tRCIP/7 -0.4	6*tRCIP/7	6*tRCIP/7 +0.4	nsec	

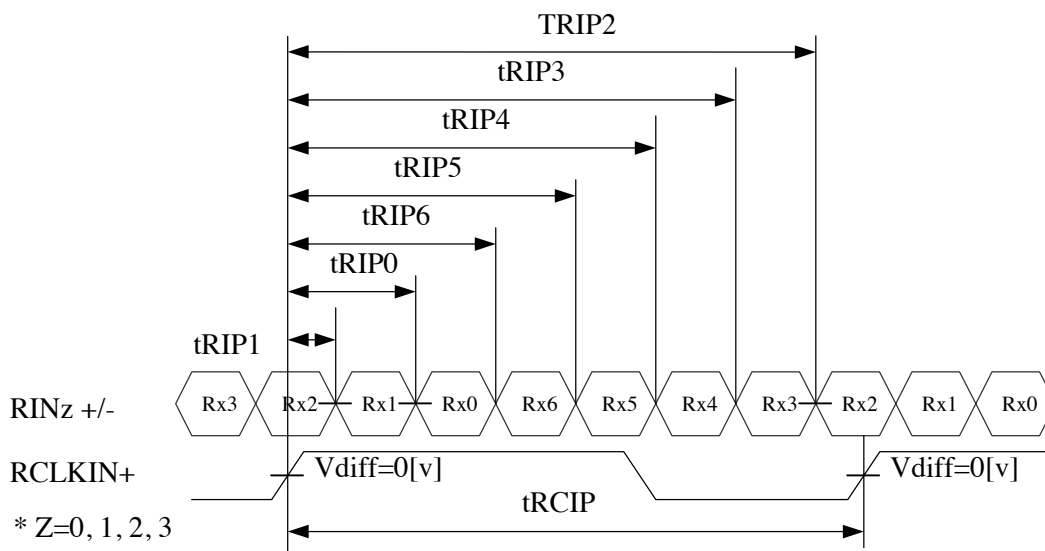

\* Vdiff = (RINz+)-(RINz-), (RCLKIN+)-(RCLKIN-)

SPEC. NUMBER  
S864-1132

SPEC. TITLE  
HT10X21-100 Product Specification

PAGE  
12 OF 22



**PRODUCT GROUP**

REV.

ISSUE DATE

TFT-LCD PRODUCT

0

2003.01.30

**7.0 SIGNAL TIMING WAVEFORMS OF INTERFACE SIGNAL (DE MODE)**

7.1 Vertical Timing Waveforms

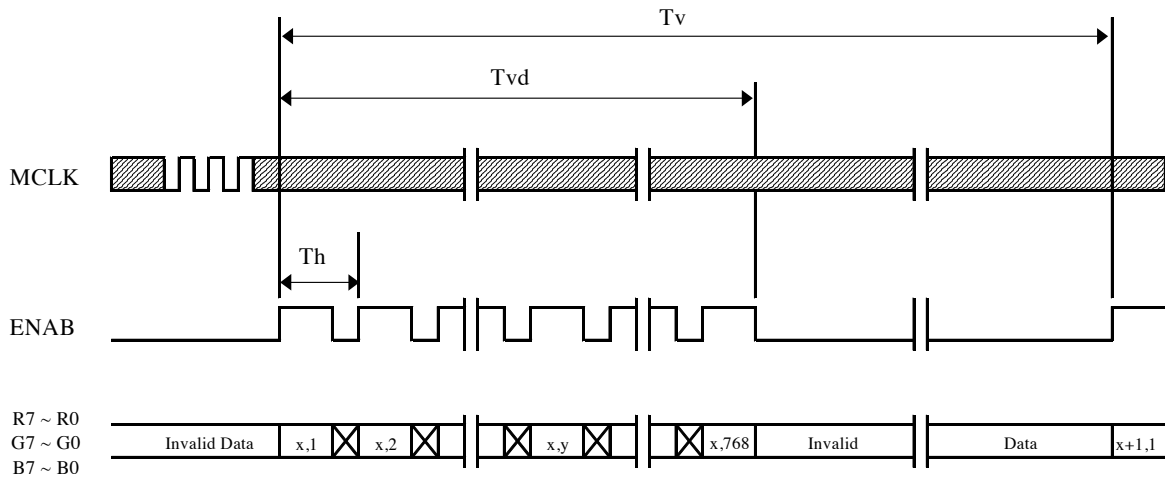

7.2 Horizontal Timing Waveforms

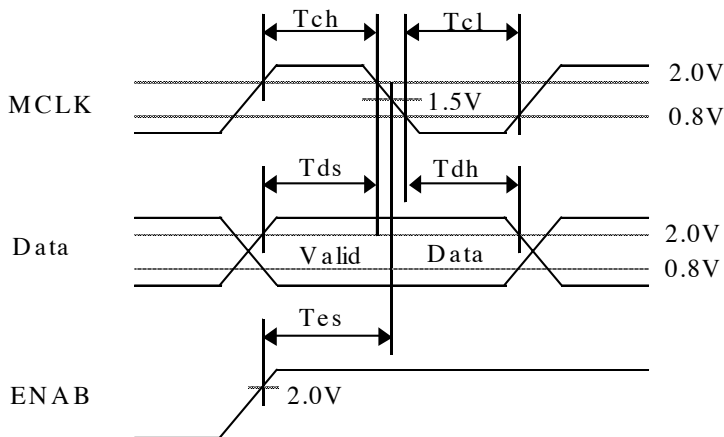
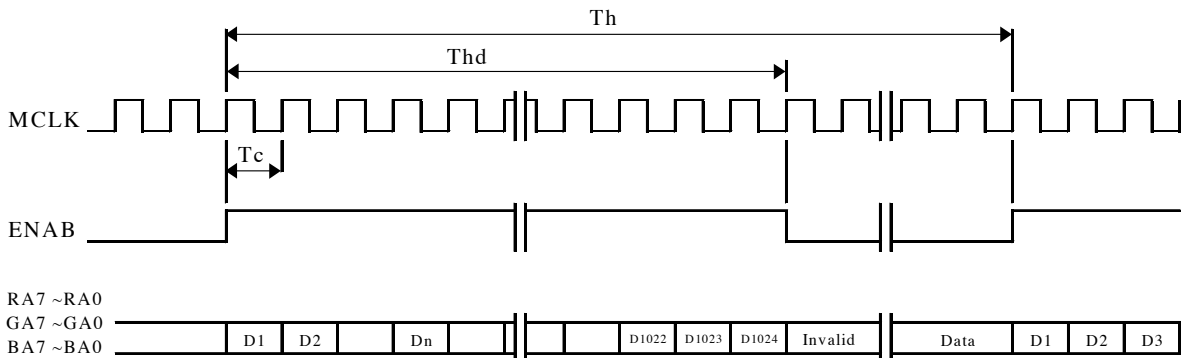

SPEC. NUMBER  
S864-1132

SPEC. TITLE  
HT10X21-100 Product Specification

PAGE  
13 OF 22



**PRODUCT GROUP**

REV.

ISSUE DATE

TFT-LCD PRODUCT

0

2003.01.30

**8.0 INPUT SIGNALS, BASIC DISPLAY COLORS & GRAY SCALE OF COLORS**

Colors & Gray Scale		Red Data						Green Data						Blue Data					
		R5	R4	R3	R2	R1	R0	G5	G4	G3	G2	G1	G0	B5	B4	B3	B2	B1	B0
Basic Colors	Black	0	0	0	0	0	0	0	0	0	0	0	0	0	0	0	0	0	0
	Blue	0	0	0	0	0	0	0	0	0	0	0	0	1	1	1	1	1	1
	Green	0	0	0	0	0	0	1	1	1	1	1	1	0	0	0	0	0	0
	Cyan	0	0	0	0	0	0	1	1	1	1	1	1	1	1	1	1	1	1
	Red	1	1	1	1	1	1	0	0	0	0	0	0	0	0	0	0	0	0
	Magenta	1	1	1	1	1	1	0	0	0	0	0	0	1	1	1	1	1	1
	Yellow	1	1	1	1	1	1	1	1	1	1	1	1	0	0	0	0	0	0
	White	1	1	1	1	1	1	1	1	1	1	1	1	1	1	1	1	1	1
Gray Scale Of Red	Black	0	0	0	0	0	0	0	0	0	0	0	0	0	0	0	0	0	0
	△	0	0	0	0	0	1	0	0	0	0	0	0	0	0	0	0	0	0
	Darker	0	0	0	0	1	0	0	0	0	0	0	0	0	0	0	0	0	0
	▽	↓						↓						↓					
	Brighter	1	1	1	1	0	1	0	0	0	0	0	0	0	0	0	0	0	0
	▽	1	1	1	1	1	0	0	0	0	0	0	0	0	0	0	0	0	0
Gray Scale Of Green	Red	1	1	1	1	1	1	0	0	0	0	0	0	0	0	0	0	0	0
	Black	0	0	0	0	0	0	0	0	0	0	0	0	0	0	0	0	0	0
	△	0	0	0	0	0	0	0	0	0	0	0	1	0	0	0	0	0	0
	Darker	0	0	0	0	0	0	0	0	0	0	1	0	0	0	0	0	0	0
	▽	↓						↓						↓					
	Brighter	0	0	0	0	0	0	1	1	1	1	0	1	0	0	0	0	0	0
Gray Scale Of Blue	▽	0	0	0	0	0	0	1	1	1	1	1	0	0	0	0	0	0	
	Green	0	0	0	0	0	0	1	1	1	1	1	1	0	0	0	0	0	0
	Black	0	0	0	0	0	0	0	0	0	0	0	0	0	0	0	0	0	0
	△	0	0	0	0	0	0	0	0	0	0	0	0	0	0	0	0	0	1
	Darker	0	0	0	0	0	0	0	0	0	0	0	0	0	0	0	0	1	0
	▽	↓						↓						↓					
Gray Scale Of White & Black	Brighter	0	0	0	0	0	0	0	0	0	0	0	1	1	1	1	0	1	
	▽	0	0	0	0	0	0	0	0	0	0	0	1	1	1	1	1	0	
	Blue	0	0	0	0	0	0	0	0	0	0	0	1	1	1	1	1	1	1
	Black	0	0	0	0	0	0	0	0	0	0	0	0	0	0	0	0	0	0
	△	0	0	0	0	0	1	0	0	0	0	0	1	0	0	0	0	0	1
	Darker	0	0	0	0	1	0	0	0	0	0	1	0	0	0	0	0	1	0
Gray Scale Of White & Black	▽	↓						↓						↓					
	Brighter	1	1	1	1	0	1	1	1	1	1	0	1	1	1	1	1	0	1
Gray Scale Of White & Black	▽	1	1	1	1	1	0	1	1	1	1	1	0	1	1	1	1	1	0
	White	1	1	1	1	1	1	1	1	1	1	1	1	1	1	1	1	1	1

SPEC. NUMBER  
S864-1132

SPEC. TITLE  
HT10X21-100 Product Specification

PAGE  
14 OF 22



**PRODUCT GROUP**

REV.

ISSUE DATE

TFT-LCD PRODUCT

0

2003.01.30

### 9.0 POWER SEQUENCE

To prevent a latch-up or DC operation of the LCD module, the power on/off sequence should be as shown in below

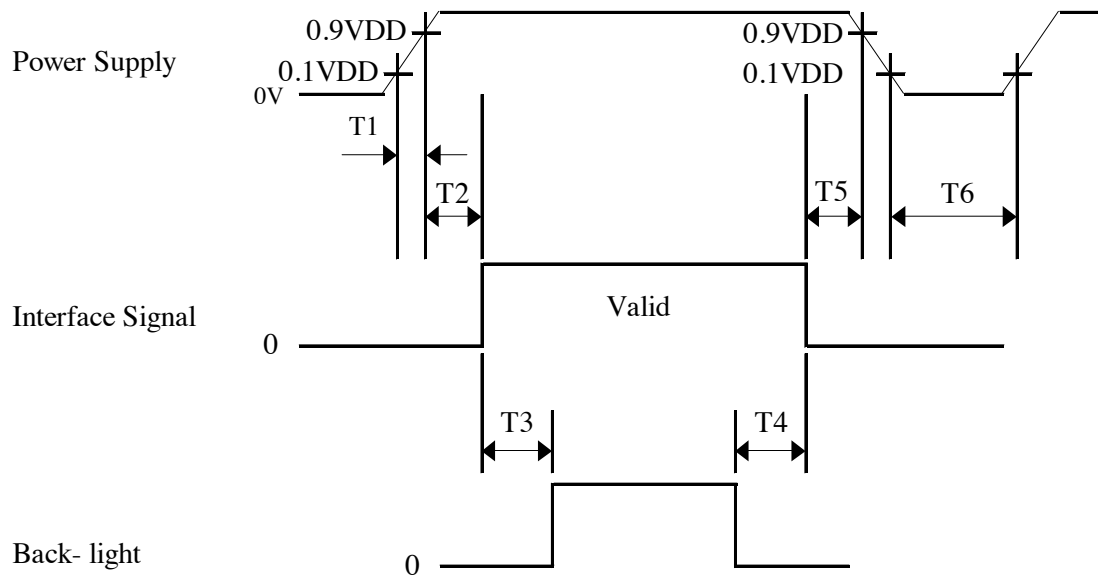

- $0 < T1 \leq 10 \text{ ms}$
- $0 < T2 \leq 50 \text{ ms}$
- $100 \text{ ms} \leq T3, T4$
- $0 < T5 \leq 50 \text{ ms}$
- $1 \text{ sec} < T6$

Notes:

1. When the power supply VDD is 0V, Keep the level of input signals on the low or keep high impedance.
2. Do not keep the interface signal high impedance when power is on.
3. Back Light must be turn on after power for logic and interface signal are valid.

SPEC. NUMBER  
S864-1132

SPEC. TITLE  
HT10X21-100 Product Specification

PAGE  
15 OF 22

**PRODUCT GROUP**

REV.

ISSUE DATE

TFT-LCD PRODUCT

0

2003.01.30

**10.0 MECHANICAL CHARACTERISTICS**

## 10.1 Dimensional Requirements

FIGURE 5, 6 shown in appendix shows mechanical outlines for the model.

Parameter	Specification	Unit
Dimensional outline		
Horizontal	238.6±0.5	mm
Vertical	173.2±0.5	
Thickness	5.0Max., 6.8Max.	
Weight	235 typ.	gram
Active area	210.432 (H) × 157.824(V)	mm
Pixel pitch	0.2055(H) × 0.2055(V)	mm
Number of pixels	1024(H) × 768(V)	pixels

## 10.2 Mounting

See FIGURE 5 shown in appendix

## 10.3 Anti-Glare and Polarizer Hardness.

The surface of the LCD has an anti-glare coating to minimize reflection and a coating to reduce scratching.

## 10.4 Light Leakage

There shall not be visible light from the back-lighting system around the edges of the screen as seen from a distance 50 cm from the screen with an overhead light level of 150lux. The manufacture shall furnish limit samples of the panel showing the light leakage acceptable.

SPEC. NUMBER  
S864-1132SPEC. TITLE  
HT10X21-100 Product SpecificationPAGE  
16 OF 22





**PRODUCT GROUP**

REV.

ISSUE DATE

TFT-LCD PRODUCT

0

2003. 01. 30

**11.0 RELIABILITY TEST**

No	Test Items	Conditions
1	High temperature storage test	Ta = 60 °C, 240 hrs
2	Low temperature storage test	Ta = -20 °C, 240 hrs
3	High temperature & high humidity operation test	Ta = 50 °C, 80 %RH, 240 hrs
4	High temperature operation test	Ta = 50 °C, 240 hrs
5	Low temperature operation test	Ta = 0 °C, 240 hrs
6	Thermal shock	Ta = -20 °C ↔ 60 °C (30 min), 100 cycle
7	Vibration test (non-operating)	Frequency : 10 ~ 300 Hz Gravity/AMP : 1.5G Period : X, Y, Z 30 min
8	Shock test (non-operating)	Gravity : 150G Pulse width : 6ms, half sine wave ±X, ±Y, ±Z Once for each direction
9	Electrostatic discharge test	Air : 150 pF, 330 Ω, 15KV Contact : 150 pF, 330 Ω, 8KV

NOTE: vibration test and shock test should be done with digitizer board inserted.

SPEC. NUMBER  
S864-1132

SPEC. TITLE  
HT10X21-100 Product Specification

PAGE  
17 OF 22



**PRODUCT GROUP**

REV.

ISSUE DATE

TFT-LCD PRODUCT

0

2003.01.30

**12.0 HANDLING & CAUTIONS**

12.1 Cautions when taking out the module

- Pick the pouch only, when taking out module from a shipping package.

12.2 Cautions for handling the module

- As the electrostatic discharges may break the LCD module, handle the LCD module with care. Peel a protection sheet off from the LCD panel surface as slowly as possible.
- As the LCD panel and backlight element are made from fragile glass material, impulse and pressure to the LCD module should be avoided.
- As the surface of the polarizer is very soft and easily scratched, use a soft dry cloth without chemicals for cleaning.
- Do not pull the interface connector in or out while the LCD module is operating.
- Put the module display side down on a flat horizontal plane.
- Handle connectors and cables with care.

12.3 Cautions for the operation

- When the module is operating, do not lose MCLK, DE signals. If any one of these signals were lost, the LCD panel would be damaged.
- Obey the supply voltage sequence. If wrong sequence were applied, the module would be damaged.

12.4 Cautions for the atmosphere

- Dewdrop atmosphere should be avoided.
- Do not store and/or operate the LCD module in a high temperature and/or humidity atmosphere. Storage in an electro-conductive polymer-packing pouch and under relatively low temperature atmosphere is recommended.

12.5 Cautions for the module characteristics

- Do not apply fixed pattern data signal to the LCD module at product aging.
- Applying fixed pattern for a long time may cause image sticking.

12.6 Other cautions

- Do not disassemble and/or re-assemble LCD module.
- Do not re-adjust variable resistor or switch etc.
- When returning the module for repair or etc, please pack the module not to be broken. We recommend using the original shipping packages.

SPEC. NUMBER  
S864-1132

SPEC. TITLE  
HT10X21-100 Product Specification

PAGE  
18 OF 22



PRODUCT GROUP

REV.

ISSUE DATE

TFT-LCD PRODUCT

0

2003.01.30

13.0 APPENDIX

Figure 1. Measurement Set Up

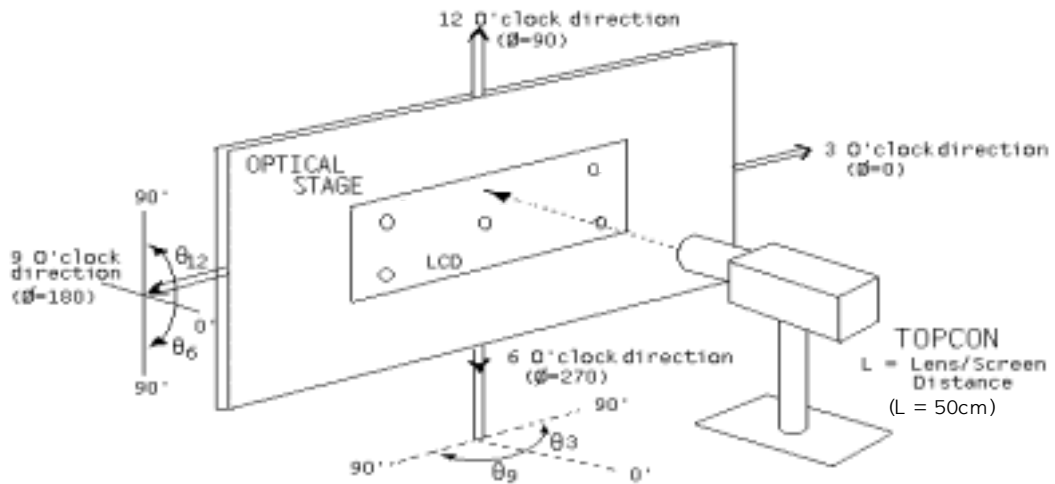
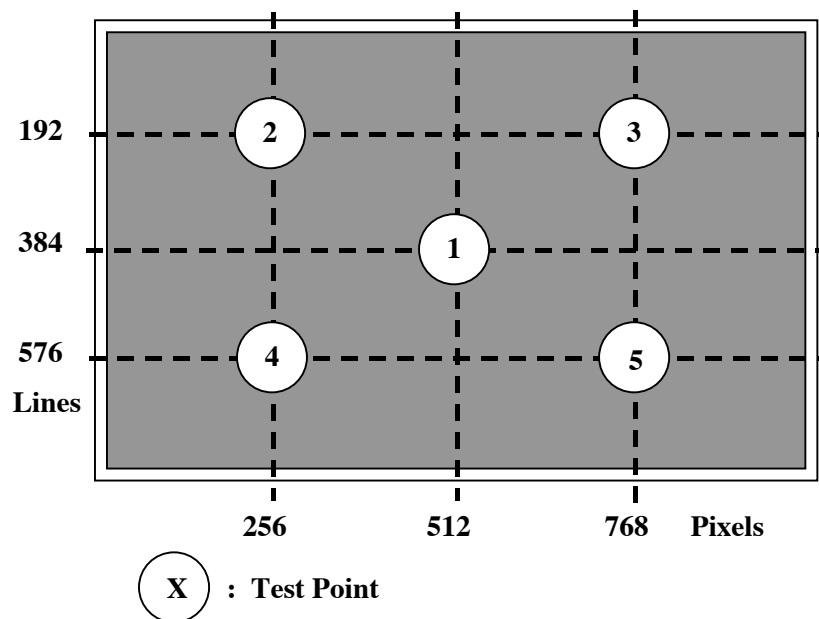

Figure 2. Average Luminance Measurement Locations & Uniformity Measurement Locations



SPEC. NUMBER  
S864-1132

SPEC. TITLE  
HT10X21-100 Product Specification

PAGE  
19 OF 22



**PRODUCT GROUP**

REV.

ISSUE DATE

TFT-LCD PRODUCT

0

2003.01.30

**Figure 3. Response Time Testing**

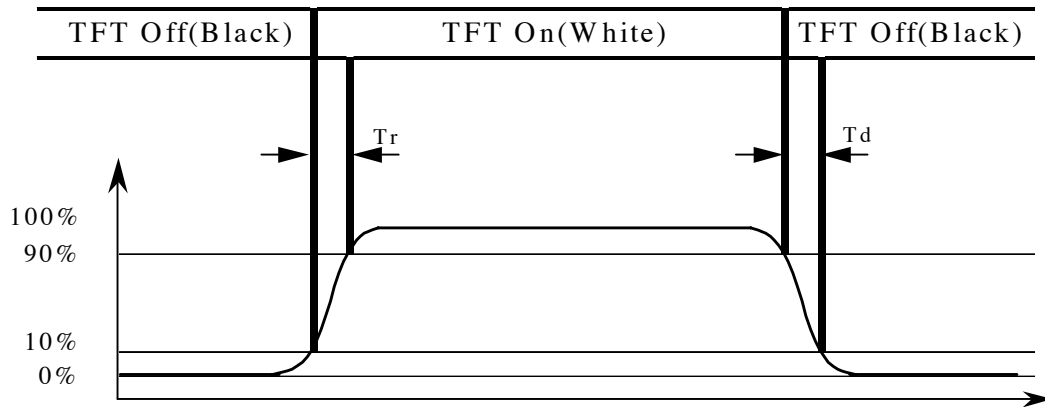

**Figure 4. Cross Modulation Test Description**

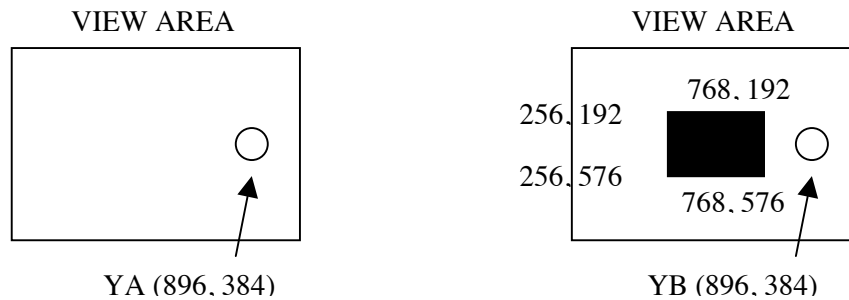

$$\text{Cross-Talk} = \left| \frac{Y_B - Y_A}{Y_A} \right| \times 100$$

Where:

$Y_A$  = Initial luminance of measured area (cd/m<sup>2</sup>)

$Y_B$  = Subsequent luminance of measured area (cd/m<sup>2</sup>)

The location measured will be exactly the same in both patterns.

SPEC. NUMBER  
S864-1132

SPEC. TITLE  
HT10X21-100 Product Specification

PAGE  
20 OF 22



PRODUCT GROUP

REV.

ISSUE DATE

TFT-LCD PRODUCT

0

2003.01.30

Figure 5. TFT-LCD Module Outline Dimensions (Front view)

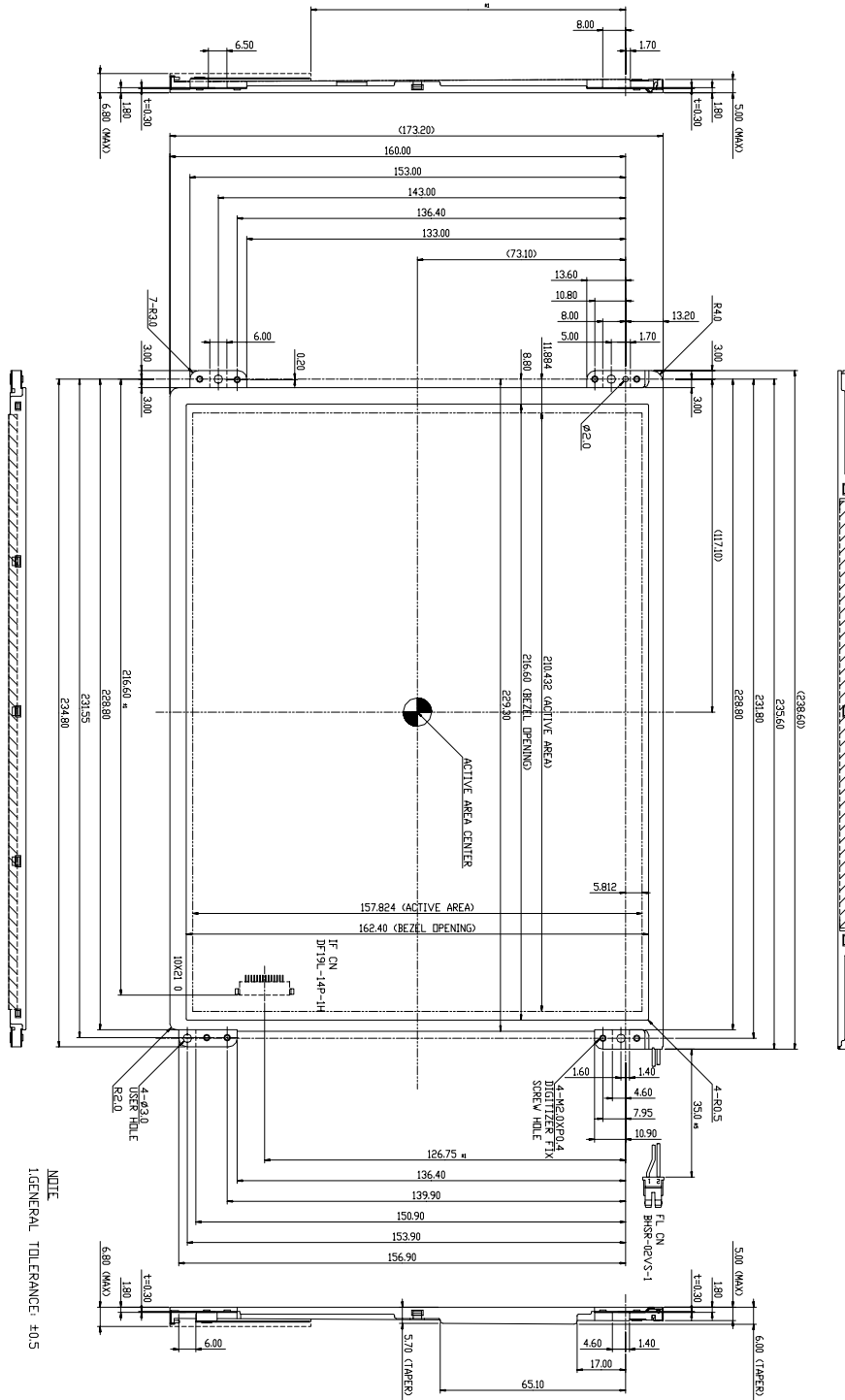

SPEC. NUMBER  
S864-1132

SPEC. TITLE  
HT10X21-100 Product Specification

PAGE  
21 OF 22



PRODUCT GROUP

REV.

ISSUE DATE

TFT-LCD PRODUCT

0

2003.01.30

Figure 6. TFT-LCD Module Outline Dimensions (Rearview)

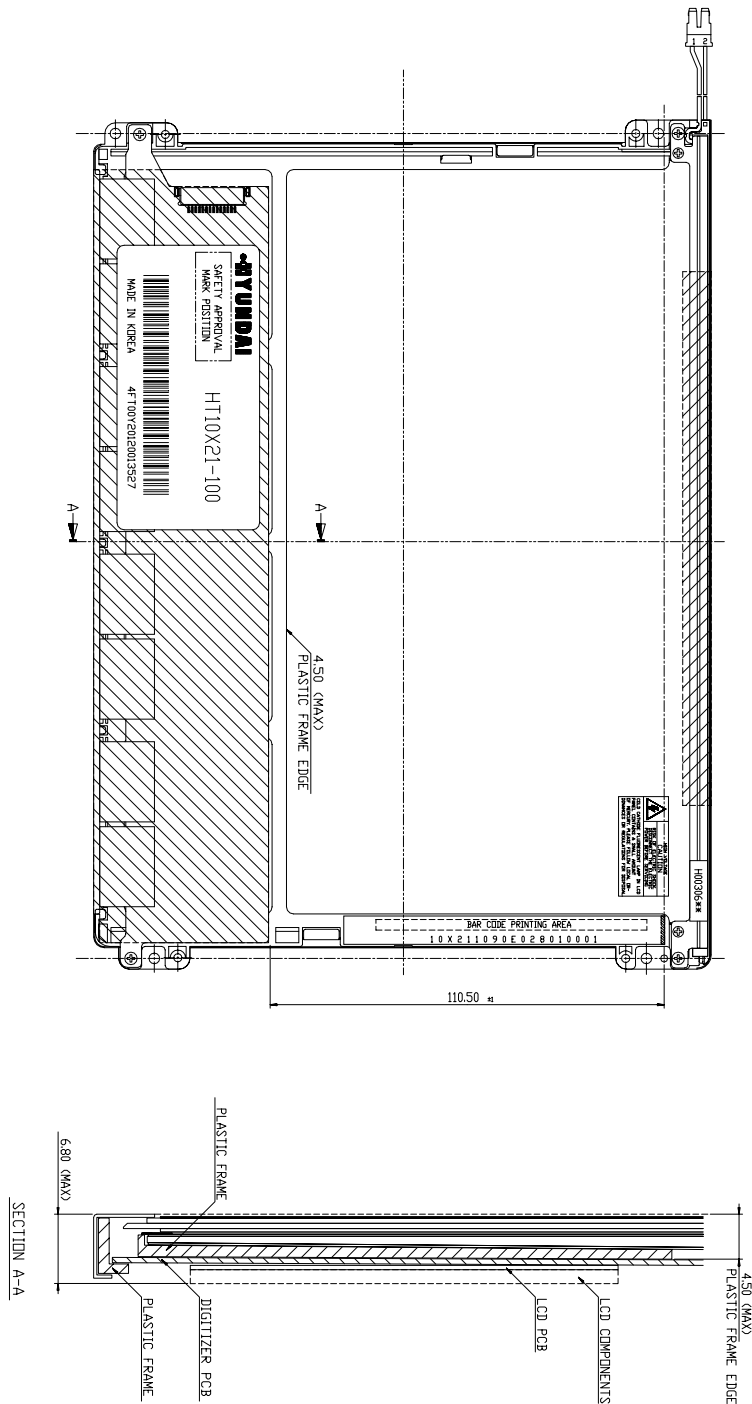

SPEC. NUMBER  
S864-1132

SPEC. TITLE  
HT10X21-100 Product Specification

PAGE  
22 OF 22