



PROPRIETARY NOTE
THIS SPECIFICATION IS THE PROPERTY OF HYDIS AND SHALL NOT
BE REPRODUCED OR COPIED WITHOUT THE WRITTEN PERMISSION OF
HYDIS AND MUST BE RETURNED TO HYDIS UPON ITS REQUEST

TITLE : HT10X21-331
Product Specification
Rev. A

FOR MORE INFORMATION:
AZ DISPLAYS, INC.
75 COLUMBIA, ALISO VIEJO, CA, 92656
[Http://www.AZDISPLAYS.com](http://www.AZDISPLAYS.com)

HYDIS Technologies

SPEC. NUMBER S864-1331	PRODUCT GROUP TFT-LCD PRODUCTS	REV. A	ISSUE DATE 2007. 11.05	1 / 25
---------------------------	-----------------------------------	-----------	---------------------------	--------

B2005-C001-C(1/3) A4(210x297)
HYDIS



PRODUCT GROUP

REV

ISSUE DATE

TFT-LCD PRODUCT

A

2007.11.05

REVISION HISTORY

REV.	ECN NO.	DESCRIPTION OF CHANGES	DATE	PREPARED
0		Initial Release (HT10X21-331 is based on HT10X21-311, and B/L sheet angle is only change to 5°)	07.05.21	S.W. Kang
A	E0710-F011	Updated section : 15.0_Figure 5. Tolerance value of outline dimension is updated.	07.11.05	S.W. Kang

SPEC. NUMBER
S864-1331

SPEC. TITLE
HT10X21-331 Product Specification

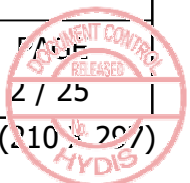

B2005-C001-C(2/3)

A4(210 x 297)



PRODUCT GROUP

REV

ISSUE DATE

TFT-LCD PRODUCT

A

2007.11.05

CONTENS

NO.	ITEM	PAGE
1.0	General Description	4
2.0	Absolute Maximum ratings	6
3.0	Electrical specifications	7
4.0	Optical specifications	8
5.0	Interface Connection	10
6.0	Signal Timing Specification	12
7.0	Signal Timing waveforms of interface signal (DE mode)	13
8.0	Input Signals, Display Colors & Gray Scale of Colors	14
9.0	Power Sequence	15
10.0	Mechanical Characteristics	16
11.0	Reliability Test	17
12.0	Handling & Cautions	18
13.0	Packing	19
14.0	Environment & Safety	20
15.0	Appendix	22

SPEC. NUMBER
S864-1331

SPEC. TITLE
HT10X21-331 Product Specification

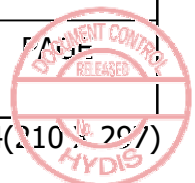

B2005-C001-C(3/3)

A4(210 x 297)



PRODUCT GROUP

REV

ISSUE DATE

TFT-LCD PRODUCT

A

2007.11.05

1.0 GENERAL DESCRIPTION

1.1 Introduction

HT10X21-331 is a color active matrix TFT LCD module using amorphous silicon TFT's (Thin Film Transistors) as active switching devices. This module has a 10.4 inch diagonally measured active area with XGA resolutions (1024 horizontal by 768 vertical pixel array). Each pixel is divided into RED, GREEN, BLUE dots which are arranged in vertical stripe and this module can display 262,144 colors. The TFT-LCD panel used for this module is a low reflection and higher color type.

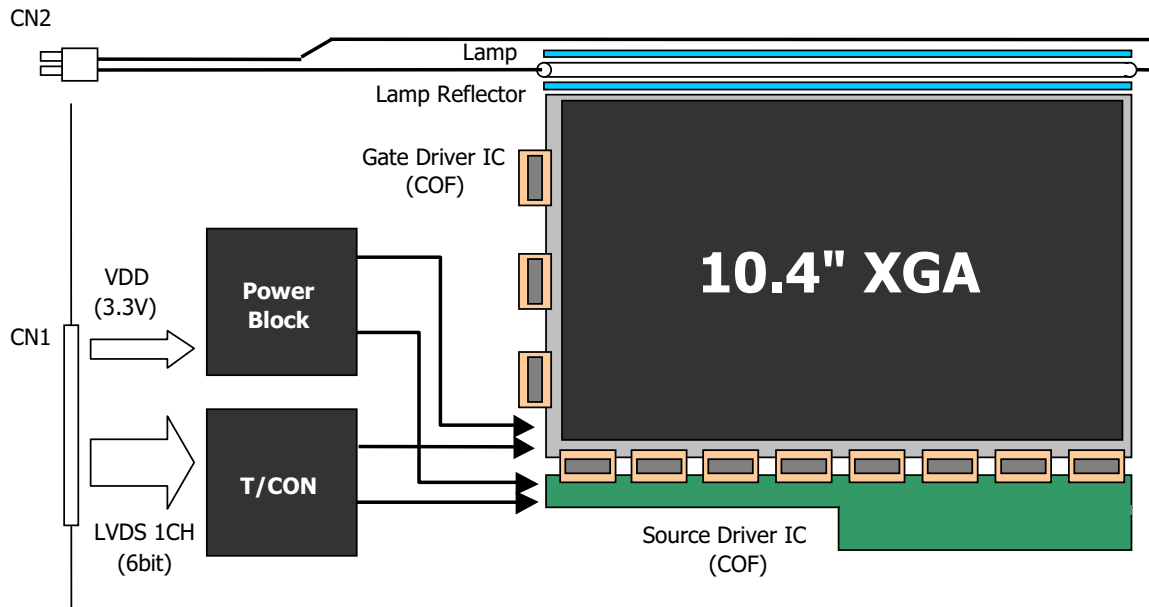

1.2 Features

- 1) 1Ch LVDS Interface with 1 pixel / clock
- 2) 6-bit color depth, Display 262,144 colors
- 3) Incorporated edge type back-light (1 lamp)
- 4) High luminance and contrast ratio, low reflection and wide viewing angle
- 5) Front Mounting Frame
- 6) DE (Data Enable) mode only
- 7) SLG (Single Level Gate) function use
- 8) RoHS Product
- 9) Optimization for direct bonding

1.3 Application

Pen type & Tablet PC

SPEC. NUMBER
S864-1331

SPEC. TITLE
HT10X21-331 Product Specification

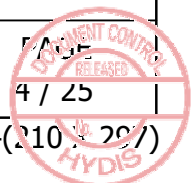

B2005-C001-C(3/3)

A4(210 x 297)



PRODUCT GROUP

REV

ISSUE DATE

TFT-LCD PRODUCT

A

2007.11.05

1.3 General Specifications

PARAMETER	SPECIFICATION	UNIT	REMARK
Active area	210.432 X 157.824	mm	
Number of pixels	1024(H) × 768(V)	pixels	
Pixel pitch	0.2055(H) × 0.2055(V)	mm	
Pixel arrangement	RGB Vertical stripe		
Display colors	262,144	colors	
Display mode	Normally Black		
Dimensional outline	238.6 (H) X 173.2 (V) X 5.0 max. (Lamp) 6.8 max. (Component)	mm	
Weight	225 Typ. / 235 Max.	gram	
Back-light	Top edge side 1-CCFL type (Cold Cathode Fluorescent Lamp)		
Surface treatment	Haze 25, Anti-glare & hard-coating (3H)		

SPEC. NUMBER
S864-1331

SPEC. TITLE
HT10X21-331 Product Specification

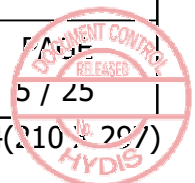

B2005-C001-C(3/3)

A4(210 X 297)



PRODUCT GROUP

REV

ISSUE DATE

TFT-LCD PRODUCT

A

2007.11.05

2.0 ABSOLUTE MAXIMUM RATINGS

The followings are maximum values which, if exceed, may cause faulty operation or damage to the unit.

PARAMETER	SYMBOL	MIN.	MAX.	UNIT	REMARK
Logic Power Supply	V_{DD}	VSS-0.3	4.0	V	Ta = 25 ± 2 °C
Logic Input Voltage	V_{IN}	VSS-0.3	$V_{DD}+0.3$	V	
Back-light Lamp Current	I_{BL}	2.0	7.0	mA	
Back-light Frequency	F_L	40	80	KHz	
Operating Temperature (Humidity)	T_{OP}	0	+50 80	°C %	Note 1 ≤ 40 °C
Storage Temperature	T_{ST}	-20	+60 90	°C %	Note 1 ≤ 40 °C

Note 1. Temperature and relative humidity range are shown in the figure below.

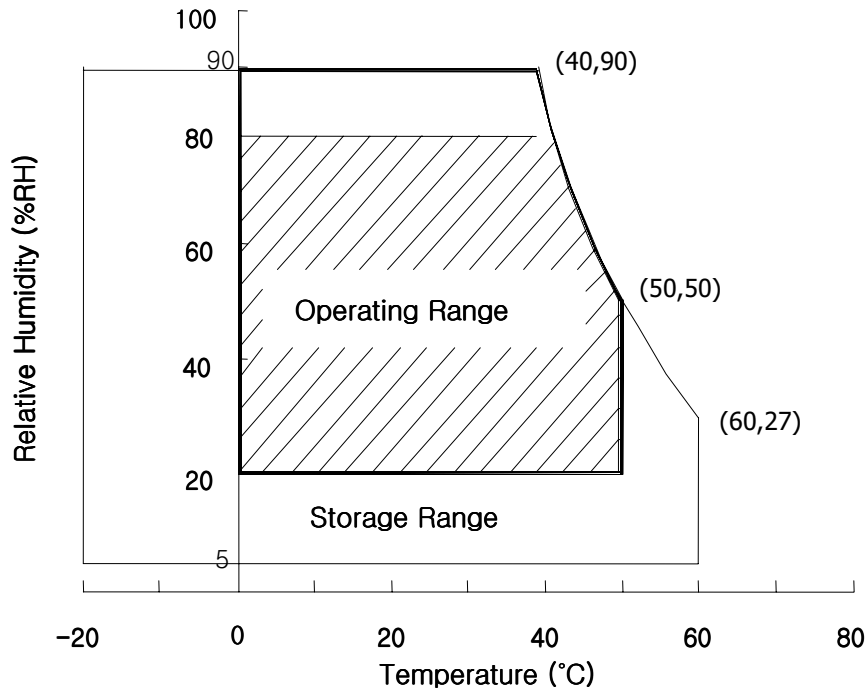

SPEC. NUMBER
S864-1331

SPEC. TITLE
HT10X21-331 Product Specification

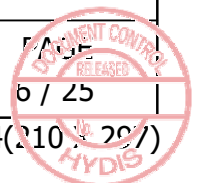

B2005-C001-C(3/3)

A4(210, 297)



PRODUCT GROUP

REV

ISSUE DATE

TFT-LCD PRODUCT

A

2007.11.05

3.0 ELECTRICAL SPECIFICATIONS

Ta = 25±2°C

PARAMETER		MIN.	TYP.	MAX.	UNIT	REMARK
Power Supply Voltage	V _{DD}	3.0	3.3	3.6	V	
Power Supply Current	I _{DD}	-	210		mA	Note 1
CCFL Ignition Time	t	-	-	100	mV	V _{DD} = 3.3V
High Level Differential Input Signal Voltage	V _{IH}	-	-	+100	mV	V _{cm} = 1.2V typ.
Low Level Differential Input Signal Voltage	V _{IL}	-100	-	-	mV	
Back-light Lamp Voltage	V _{BL}	-	520	-	V _{rms}	
Back-light Lamp Current	I _{BL}	2.0	5.0	6.0	mA _{rm}	
Back-light Lamp operating Frequency	F _L	40	60	80	KHz	Note 2
Lamp Start Voltage				950	V _{rms}	Ta = 25°C, Note 3
				1150	V _{rms}	Ta = 0°C, Note 3
Lamp Life		10,000			hrs	I _{BL} = 2.0~6.0mA
Power Consumption	P _D		0.7		W	
	P _{BL}		2.6		W	I _{BL} = 5.0mA, Note 4
	P _{total}		3.3		W	

Notes :

- The supply voltage is measured and specified at the interface connector of LCM.
The current draw and power consumption specified is for VDD = 3.3V, Frame rate = 60 Hz and Clock frequency = 65MHz.
Test Pattern of power supply current
a) Typ : Vertical color bar pattern
b) Max : Gray 28 @ Vertical 2 Skip line pattern
- The lamp frequency should be selected as different as possible from the horizontal synchronous frequency and its harmonics to avoid interference, which may cause line flow on the display
- The voltage above this value should be applied to the lamps for more than 1 second to startup. Otherwise the lamps may not to be turned on.
- Calculated value for reference (VBL × IBL) excluding inverter loss.

SPEC. NUMBER
S864-1331

SPEC. TITLE
HT10X21-331 Product Specification



B2005-C001-C(3/3)

A4(210 × 297)



PRODUCT GROUP

REV

ISSUE DATE

TFT-LCD PRODUCT

A

2007.11.05

4.0 OPTICAL SPECIFICATION

The test of Optical specifications shall be measured in a dark room (ambient luminance ≤ 1 lux and temperature = $25 \pm 2^\circ\text{C}$) with the equipment of Luminance meter system (Goniometer system and TOPCONE BM-5) and test unit shall be located at an approximate distance 50cm from the LCD surface at a viewing angle of θ and ϕ equal to 0° . We refer to $\theta_{\phi=0}$ ($=\theta_3$) as the 3 o'clock direction (the "right"), $\theta_{\phi=90}$ ($=\theta_{12}$) as the 12

o'clock direction ("upward"), $\theta_{\phi=180}$ ($=\theta_9$) as the 9 o'clock direction ("left") and $\theta_{\phi=270}$ ($=\theta_6$) as the 6 o'clock

direction ("bottom"). While scanning θ and/or ϕ , the center of the measuring spot on the Display surface shall stay fixed. The backlight should be operating for 30 minutes prior to measurement... VDD shall be 3.3 +/- 0.3V at 25°C . Optimum viewing angle direction is 6 o'clock.

PARAMETER		SYMBOL	CONDITION	MIN.	TYP.	MAX.	UNIT	REMARK
Viewing Angle Range	Horizontal	θ_3	CR > 10	-	80	-	Deg.	Note 1
		θ_9		-	80	-	Deg.	
	Vertical	θ_{12}		-	80	-	Deg.	
		θ_6		-	80	-	Deg.	
Luminance Contrast ratio		CR	$\theta = 0^\circ$	-	500	-		Note 2
Luminance of White		Y_L	$\theta = 0^\circ$ IBL = 6mA	140	170	-	cd/m ²	Note 3
White Luminance Uniformity		ΔY_5	Ta= 25° C $\theta = 0^\circ$	70	-	-	%	Note 4
White Chromaticity		x_w		0.288	0.318	0.348		Note 5
		y_w		0.313	0.343	0.373		
Reproduction of Color	Red	x_R		0.553	0.583	0.613		
		y_R		0.307	0.337	0.367		
	Green	x_G		0.280	0.310	0.340		
		y_G		0.518	0.548	0.578		
	Blue	x_B		0.120	0.150	0.180		
		y_B		0.118	0.148	0.178		
Color Reproduction				-	45	-	%	
Response Time		$T_r + T_d$	-	40	45	ms	Note 6	
Cross Talk		CT	-	-	2.0	%	Note 7	

SPEC. NUMBER
S864-1331

SPEC. TITLE
HT10X21-331 Product Specification

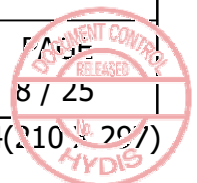

B2005-C001-C(3/3)

A4(210x297)



PRODUCT GROUP

REV

ISSUE DATE

TFT-LCD PRODUCT

A

2007.11.05

Note : 1. Viewing angle is the angle at which the contrast ratio is greater than 10. The viewing are determined for the horizontal or 3, 9 o'clock direction and the vertical or 6, 12 o'clock direction with respect to the optical axis which is normal to the LCD surface (see FIGURE 1 shown in Appendix).

2. Contrast measurements shall be made at viewing angle of Θ= 0° and at the center of the LCD surface. Luminance shall be measured with all pixels in the view field set first to white, then to the dark (black) state. (See FIGURE 1 shown in Appendix)

Luminance Contrast Ratio (CR) is defined mathematically.

CR = (Luminance when displaying a white raster) / (Luminance when displaying a black raster)

3. Luminance of white is defined as a center point(#1) on LCD surface. Luminance shall be measured with all pixels in the view field set first to white. This measurement shall be taken at the locations shown in FIGURE 2 for a total of the measurements per display.

4. The White luminance uniformity on LCD surface is then expressed. (See FIGURE 2 shown in Appendix).

Uniformity ΔY = (Minimum Luminance of 5 points / Maximum Luminance of 5 points) X 100 (%)

5. The color chromaticity coordinates specified in Table 4 shall be calculated from the spectral data measured with all pixels first in red, green, blue and white. Measurements shall be made at the center of the panel.

6. The electro-optical response time measurements shall be made as FIGURE 3 shown in Appendix by switching the "data" input signal OFF and ON. The times needed for the luminance to change from 10% to 90% is Tr, and 90% to 10% is Td.

7. Cross-Talk of one area of the LCD surface by another shall be measured by comparing the luminance (YA) of a 25mm diameter area, with all display pixels set to a gray level, to the luminance (YB) of that same area when any adjacent area is driven dark. (See FIGURE 4 shown in Appendix).

SPEC. NUMBER S864-1331

SPEC. TITLE HT10X21-331 Product Specification

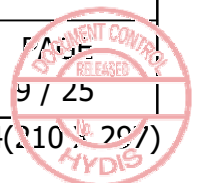

B2005-C001-C(3/3)

A4(210 X 297)



PRODUCT GROUP

REV

ISSUE DATE

TFT-LCD PRODUCT

A

2007.11.05

5.0 INTERFACE CONNECTION

5.1 Electrical Interface

CN1	Interface Connector	DF19L-14P-1H (HIROSE) or equivalent
	User side Connector	DF19G-14S-1C (HIROSE) or equivalent

PIN NO.	SYMBOL	FUNCTION	REMARK
1	VDD1	Power Supply: +3.3V	
2	VDD2	Power Supply: +3.3V	
3	VSS	Ground	
4	VSS	Ground	
5	RIN0-	LVDS Negative data signal (-)	Tx pin # 48
6	RIN0+	LVDS Positive data signal (+)	Tx pin # 47
7	RIN1-	LVDS Negative data signal (-)	Tx pin # 46
8	RIN1+	LVDS Positive data signal (+)	Tx pin # 45
9	RIN2-	LVDS Negative data signal (-)	Tx pin # 42
10	RIN2+	LVDS Positive data signal (+)	Tx pin # 41
11	RCLKIN-	LVDS Negative clock signal (-)	Tx pin # 40
12	RCLKIN+	LVDS Positive clock signal (+)	Tx pin # 39
13	VSS	Ground	
14	VSS	Ground	

5.2 Back-light Interface

CN2	Interface Connector	BHSR-02VS-1 (JST) or equivalent
	User side Connector	SM02B-BHSS-1 (JST) or equivalent

PIN NO.	INPUT	FUNCTION	REMARK
1	HOT	High voltage	Pink
2	COLD	Ground	Black

SPEC. NUMBER
S864-1331

SPEC. TITLE
HT10X21-331 Product Specification

10 / 25

B2005-C001-C(3/3)

A4(210 x 297)

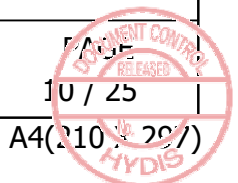



PRODUCT GROUP

REV

ISSUE DATE

TFT-LCD PRODUCT

A

2007.11.05

5.3 LVDS Interface

LVDS Transmitter : THC63LVDM83A or equivalent

INPUT SIGNAL	TRANSMITTER		INTERFACE		DF19KR-20P-1H	REMARK
	PIN NO.	PIN NO.	SYSTEM (Tx)	TFT-LCD (Rx)	PIN NO.	
R0	51	48 47	OUT0- OUT0+	IN0- IN0+	5 6	
R1	52					
R2	54					
R3	55					
R4	56					
R5	3					
G0	4	46 45	OUT1- OUT1+	IN1- IN1+	7 8	
G1	6					
G2	7					
G3	11					
G4	12					
G5	14					
B0	15	42 41	OUT2- OUT2+	IN2- IN2+	9 10	
B1	19					
B2	20					
B3	22					
B4	23					
B5	24					
HSYNC	27	40	CLKOUT-	CLKIN-	11	
VSYNC	28					
DE	30					
MCLK	31	39	CLKOUT+	CLKIN+	12	

5.4 Data Input Format

Display position of input data

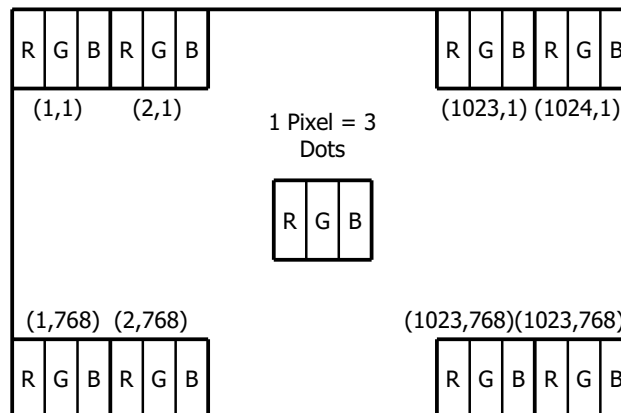

SPEC. NUMBER
S864-1331

SPEC. TITLE
HT10X21-331 Product Specification

11 / 25

B2005-C001-C(3/3)

A4(210 x 297)



PRODUCT GROUP

REV

ISSUE DATE

TFT-LCD PRODUCT

A

2007.11.05

6.0 SIGNAL TIMING SPECIFICATION

6.1 LVDS Transmitter Input

The HT10X21-331 is operated by the only DE (Data enable) mode.

ITEM	SYMBOL	MIN	TYP	MAX	UNIT
Frame Period	T1	772	806	1022	lines
Vertical Display Period	T2	-	768	-	lines
One Line Scanning Period	T3	1100	1344	2046	clocks
Horizontal Display Period	T4	1100	1344	1024	clocks
Clock Frequency	1/T5	-	65	80	MHz

6.2 LVDS Rx Interface Timing Parameter

ITEM	SYMBOL	MIN	TYP	MAX	UNIT	REMARK
CLKIN Period	tRCIP	12.5	15.38	-	nsec	
Input Data 0	tRIP0	-0.4	0.0	+0.4	nsec	
Input Data 1	tRIP1	tRCIP/7-0.4	tRCIP/7	tRCIP/7+0.4	nsec	
Input Data 2	tRIP2	2 × tRCIP/7-0.4	2 × tRCIP/7	2 × tRCIP/7+0.4	nsec	
Input Data 3	tRIP3	3 × tRCIP/7-0.4	3 × tRCIP/7	3 × tRCIP/7+0.4	nsec	
Input Data 4	tRIP4	4 × tRCIP/7-0.4	4 × tRCIP/7	4 × tRCIP/7+0.4	nsec	
Input Data 5	tRIP5	5 × tRCIP/7-0.4	5 × tRCIP/7	5 × tRCIP/7+0.4	nsec	
Input Data 6	tRIP6	6 × tRCIP/7-0.4	6 × tRCIP/7	6 × tRCIP/7+0.4	nsec	

* Vdiff = (RINz+)-(RINz-), (RCLKIN+)-(RCLKIN-)

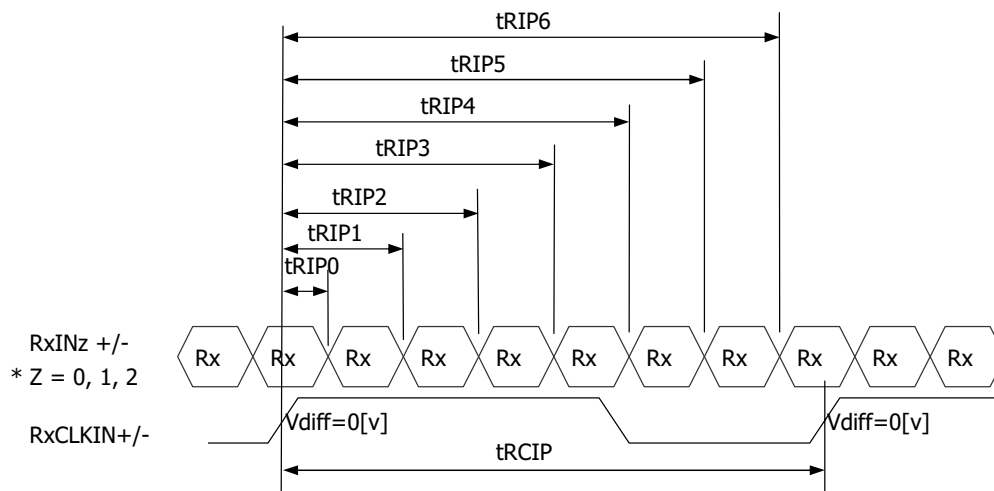

SPEC. NUMBER
S864-1331

SPEC. TITLE
HT10X21-331 Product Specification

12 / 25

B2005-C001-C(3/3)

A4(210 / 297)



PRODUCT GROUP

REV

ISSUE DATE

TFT-LCD PRODUCT

A

2007.11.05

7.0 SIGNAL TIMING WAVEFORMS OF INTERFACE SIGNAL (DE MODE)

7.1 Timing Waveforms of Interface Signal

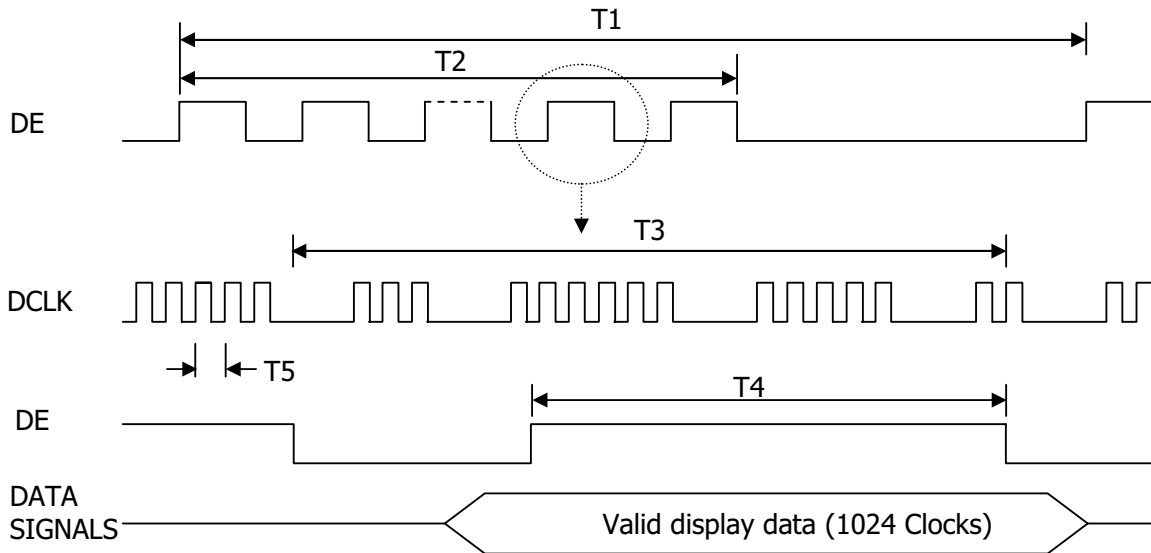

SPEC. NUMBER
S864-1331

SPEC. TITLE
HT10X21-331 Product Specification

13 / 25

B2005-C001-C(3/3)

A4(210 / 297)



PRODUCT GROUP

REV

ISSUE DATE

TFT-LCD PRODUCT

A

2007.11.05

8.0 INPUT SIGNALS, BASIC DISPLAY COLORS & GRAY SCALE OF COLORS

Each color is displayed in sixty-four gray scales from a 6 bit data signal input. A total of 262,144 colors are derived from the resultant 18 bit data.

Colors & Gray Scale	Red Data						Green Data						Blue Data						
	R5	R4	R3	R2	R1	R0	G5	G4	G3	G2	G1	G0	B5	B4	B3	B2	B1	B0	
Basic Colors	Black	0	0	0	0	0	0	0	0	0	0	0	0	0	0	0	0	0	
	Blue	0	0	0	0	0	0	0	0	0	0	0	1	1	1	1	1	1	
	Green	0	0	0	0	0	0	1	1	1	1	1	1	0	0	0	0	0	
	Cyan	0	0	0	0	0	0	1	1	1	1	1	1	1	1	1	1	1	
	Red	1	1	1	1	1	1	0	0	0	0	0	0	0	0	0	0	0	
	Magenta	1	1	1	1	1	1	0	0	0	0	0	0	1	1	1	1	1	
	Yellow	1	1	1	1	1	1	1	1	1	1	1	1	0	0	0	0	0	
	White	1	1	1	1	1	1	1	1	1	1	1	1	1	1	1	1	1	
Gray Scale Of Red	Black	0	0	0	0	0	0	0	0	0	0	0	0	0	0	0	0	0	
	△	0	0	0	0	0	1	0	0	0	0	0	0	0	0	0	0	0	
	Darker	0	0	0	0	0	1	0	0	0	0	0	0	0	0	0	0	0	
	△	↓						↓						↓					
	▽	↓						↓						↓					
	Brighter	1	1	1	1	0	1	0	0	0	0	0	0	0	0	0	0	0	
	▽	1	1	1	1	1	0	0	0	0	0	0	0	0	0	0	0	0	
	Red	1	1	1	1	1	1	0	0	0	0	0	0	0	0	0	0	0	
Gray Scale Of Green	Black	0	0	0	0	0	0	0	0	0	0	0	0	0	0	0	0	0	
	△	0	0	0	0	0	0	0	0	0	0	0	1	0	0	0	0	0	
	Darker	0	0	0	0	0	0	0	0	0	0	1	0	0	0	0	0	0	
	△	↓						↓						↓					
	▽	↓						↓						↓					
	Brighter	0	0	0	0	0	0	1	1	1	1	0	1	0	0	0	0	0	
	▽	0	0	0	0	0	0	1	1	1	1	1	0	0	0	0	0	0	
	Green	0	0	0	0	0	0	1	1	1	1	1	1	0	0	0	0	0	
Gray Scale Of Blue	Black	0	0	0	0	0	0	0	0	0	0	0	0	0	0	0	0	0	
	△	0	0	0	0	0	0	0	0	0	0	0	0	0	0	0	0	1	
	Darker	0	0	0	0	0	0	0	0	0	0	0	0	0	0	0	0	1	
	△	↓						↓						↓					
	▽	↓						↓						↓					
	Brighter	0	0	0	0	0	0	0	0	0	0	0	0	1	1	1	1	0	1
	▽	0	0	0	0	0	0	0	0	0	0	0	0	1	1	1	1	1	0
	Blue	0	0	0	0	0	0	0	0	0	0	0	0	1	1	1	1	1	1
Gray Scale Of White & Black	Black	0	0	0	0	0	0	0	0	0	0	0	0	0	0	0	0	0	
	△	0	0	0	0	0	1	0	0	0	0	0	1	0	0	0	0	1	
	Darker	0	0	0	0	1	0	0	0	0	0	1	0	0	0	0	0	1	
	△	↓						↓						↓					
	▽	↓						↓						↓					
	Brighter	1	1	1	1	0	1	1	1	1	1	0	1	1	1	1	1	0	1
	▽	1	1	1	1	1	0	1	1	1	1	1	0	1	1	1	1	1	0
	White	1	1	1	1	1	1	1	1	1	1	1	1	1	1	1	1	1	1

SPEC. NUMBER
S864-1331

SPEC. TITLE
HT10X21-331 Product Specification

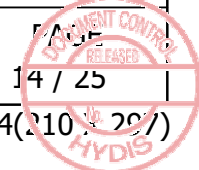

B2005-C001-C(3/3)

A4(210 x 297)



PRODUCT GROUP

REV

ISSUE DATE

TFT-LCD PRODUCT

A

2007.11.05

9.0 POWER SEQUENCE

To prevent a latch-up or DC operation of the LCD module, the power on/off sequence shall be as shown in below

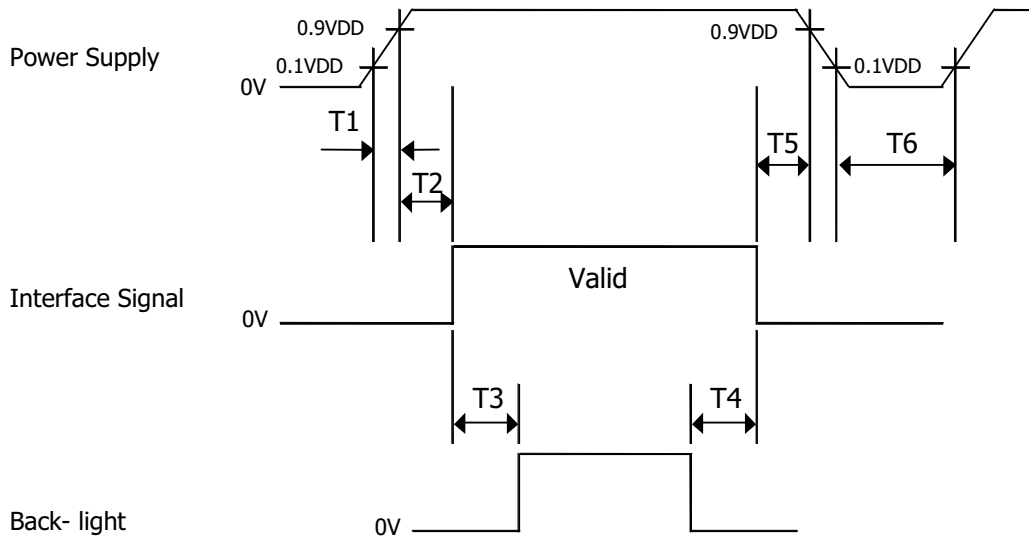

- 1) $0 < T1 \leq 10 \text{ ms}$
- 2) $0 < T2 \leq 50 \text{ ms}$
- 3) $100 \text{ ms} \leq T3$
- 4) $100 \text{ ms} \leq T4$
- 5) $0 \leq T5 \leq 50 \text{ ms}$
- 6) $1 \text{ sec} \leq T6$

- Notes :
- 1. When the power supply VDD is 0V, Keep the level of input signals on the low or keep high impedance.
 - 2. Do not keep the interface signal high impedance when power is on.
 - 3. Back Light must be turn on after power for logic and interface signal are valid.

SPEC. NUMBER
S864-1331

SPEC. TITLE
HT10X21-331 Product Specification

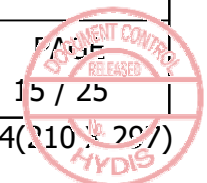

B2005-C001-C(3/3)

A4(210.3.20/)



PRODUCT GROUP

REV

ISSUE DATE

TFT-LCD PRODUCT

A

2007.11.05

10.0 MECHANICAL CHARACTERISTICS

10.1 Dimensional Requirements

FIGURE 5, 6 shown in appendix shows mechanical outlines for the model.

PARAMETER	SPECIFICATION	UNIT
Active area	210.432 (H) × 157.824 (V)	mm
Number of pixels	1024 (H) × 768 (V) (1 pixel = R + G + B dots)	pixels
Pixel pitch	0.2055 (H) × 0.2055 (V)	mm
Pixel arrangement	RGB Vertical stripe	
Display colors	262,144	colors
Display mode	Normally Black	
Dimensional outline	238.6±0.5 (W) X 173.2±0.5 (V) X 5.0 Max. (Lamp), 6.8 Max. (Component)	mm
Weight	225 Typ. / 235 Max.	g
Back-light	CCFL, horizontal-lamp type	

10.2 Mounting

See FIGURE 5. (shown in Appendix)

10.3 Anti-Reflection Polarizer

The surface of the LCD has an anti-reflection coating to minimize reflection for sunlight readability.

10.4 Light Leakage

There shall not be visible light from the back-lighting system around the edges of the screen as seen from a distance 50 cm from the screen with an overhead light level of 150lux. The manufacture shall furnish limit samples of the panel showing the light leakage acceptable.

SPEC. NUMBER
S864-1331

SPEC. TITLE
HT10X21-331 Product Specification

16 / 25

B2005-C001-C(3/3)

A4(210 X 297)

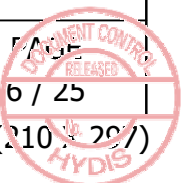



PRODUCT GROUP

REV

ISSUE DATE

TFT-LCD PRODUCT

A

2007.11.05

11.0 RELIABILITY TEST

NO	TEST ITEM	CONDITIONS
1	High temperature storage test	Ta = 60 °C, 240 hrs
2	Low temperature storage test	Ta = -20 °C, 240 hrs
3	High temperature & high humidity operation test	Ta = 50 °C, 80%RH, 240hrs
4	High temperature operation test	Ta = 50 °C, 240 hrs
5	Low temperature operation test	Ta = 0 °C, 240 hrs
6	Thermal shock	Ta = -20 °C ↔ 60 °C (30 min), 100 cycle
7	Vibration test (non-operating)	Frequency : 10~500Hz Gravity/AMP : 1.5G Period : X,Y,Z 30min
8	Shock test (non-operating)	Gravity : 150G Pulse width : 6ms, half sine wave ±X, ±Y, ±Z Once for each direction
9	Electro-Static Discharge Test (non-operating)	Air : 150pF, 330ohm, 15KV Contact : 150pF, 330ohm, 8KV

SPEC. NUMBER
S864-1331

SPEC. TITLE
HT10X21-331 Product Specification

1 / 25

B2005-C001-C(3/3)

A4(210 x 297)

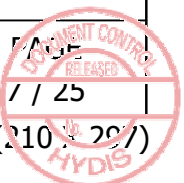

 HYDIS	PRODUCT GROUP	REV	ISSUE DATE
	TFT-LCD PRODUCT	A	2007.11.05

12.0 HANDLING & CAUTIONS

12.1 Cautions when taking out the module

- 1) Pick the pouch only, when taking out module from a shipping package.

12.2 Cautions for handling the module

- 1) As the electrostatic discharges may break the LCD module, handle the LCD module with care. Peel a protection sheet off from the LCD panel surface as slowly as possible.
- 2) As the LCD panel and backlight element are made from fragile glass material, impulse and pressure to the LCD module should be avoided.
- 3) As the surface of the polarizer is very soft and easily scratched, use a soft dry cloth without chemicals for cleaning.
- 4) Do not pull the interface connector in or out while the LCD module is operating.
- 5) Put the module display side down on a flat horizontal plane.
- 6) Handle connectors and cables with care.

12.3 Cautions for the operation

- 1) When the module is operating, do not lose MCLK, DE signals. If any one of these signals were lost, the LCD panel would be damaged.
- 2) Obey the supply voltage sequence. If wrong sequence were applied, the module would be damaged.

12.4 Cautions for the atmosphere

- 1) Dewdrop atmosphere should be avoided.
- 2) Do not store and/or operate the LCD module in a high temperature and/or humidity atmosphere. Storage in an electro-conductive polymer-packing pouch and under relatively low temperature atmosphere is recommended.

12.5 Cautions for the module characteristics

- 1) Do not apply fixed pattern data signal to the LCD module at product aging.
- 2) Applying fixed pattern for a long time may cause image sticking.

12.6 Other cautions

- 1) Do not disassemble and/or re-assemble LCD module.
- 2) Do not re-adjust variable resistor or switch etc.
- 3) When returning the module for repair or etc, please pack the module not to be broken.
- 4) We recommend using the original shipping packages.

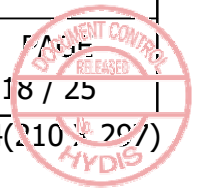
SPEC. NUMBER S864-1331	SPEC. TITLE HT10X21-331 Product Specification	
---------------------------	--	---

B2005-C001-C(3/3)

A4(210.4 20/)



PRODUCT GROUP

REV

ISSUE DATE

TFT-LCD PRODUCT

A

2007.11.05

13.0 PACKING

13.1 Packing Order

- Notes : 1. Box Dimension: mm(W) X mm(D) X mm(H)
- 2. Package Quantity in one Box: 10pcs

Put Pad into the box.



Put silica gels in the box.

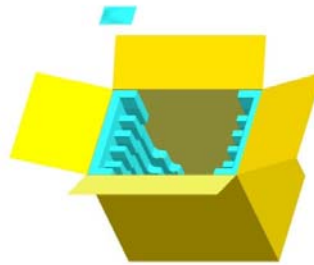

After sealing the box, attach Packing Label on the attach position sign area of the box.



Place a cover on the top of the box.

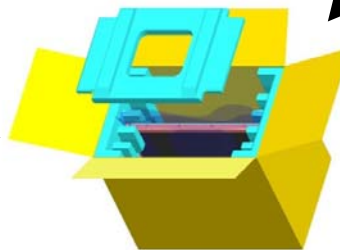

As shown in the figure, place the Modules bundled by shielding bag in the box.

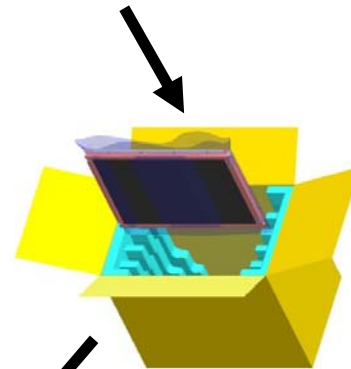

SPEC. NUMBER
S864-1331

SPEC. TITLE
HT10X21-331 Product Specification

19 / 25

B2005-C001-C(3/3)

A4(210 X 297)

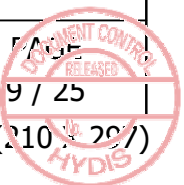



PRODUCT GROUP

REV

ISSUE DATE

TFT-LCD PRODUCT

A

2007.11.05

14.0 Environment & Safety

14.1 Packing Label

1) Label Size: 108 mm (L) × 56 mm (W)

2) Contents

Model : HT10X21-331 TFT-LCD

Q`ty : Module Q`ty in one box

Serial No. : Box Serial No. See next figure for detail description.

Date : Packing Date

FG Code : FG Code of Product

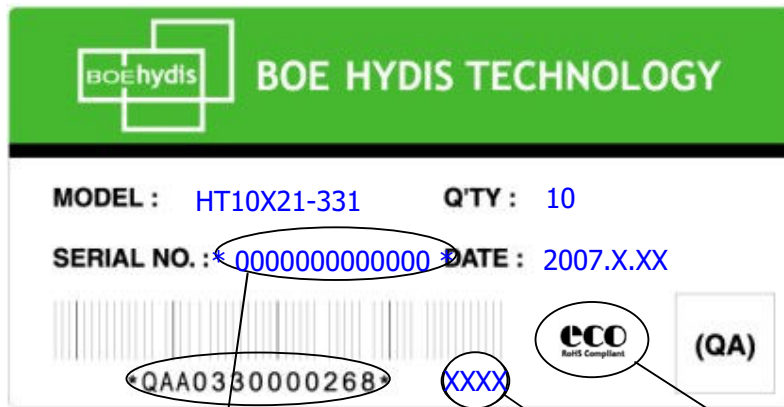

00	0	00	0	0	000000
Type	Grade	Year	Month	ITEM-CODE	Serial_no

FG CODE

RoHS Mark

14.2 Mercury disposal & High voltage caution

	HIGH VOLTAGE CAUTION	COLD CATHODE FLUORESCENT LAMP IN LCD PANEL CONTAINS A SMALL AMOUNT OF MERCURY. PLEASE FOLLOW LOCAL ORDINANCES OR REGULATIONS FOR DISPOSAL.
	RISK OF ELECTRIC SHOCK. DISCONNECT THE ELECTRIC POWER BEFORE SERVICING	

SPEC. NUMBER
S864-1331

SPEC. TITLE
HT10X21-331 Product Specification

20 / 25

B2005-C001-C(3/3)

A4(210 / 297)

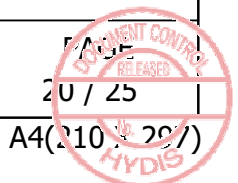



PRODUCT GROUP

REV

ISSUE DATE

TFT-LCD PRODUCT

A

2007.11.05

14.3 Product Label

1) Picture

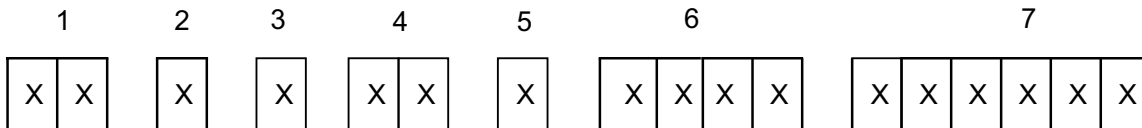

2) BOE HYDIS Barcode

- No 1. Control Number
No 2. Rank / Grade
No 3. Line Classification (BOE HYDIS : H, LCM : L, BOE OT : A/B/C)
No 4. Year (5 : 2005, 6 : 2006, ...)
No 5. Month (1, 2, 3,..., 9, X, Y, Z)
No 6. FG Code
No 7. Serial Number

SPEC. NUMBER
S864-1331

SPEC. TITLE
HT10X21-331 Product Specification

21 / 25

15.0 APPENDIX

Figure 1. Measurement Set Up

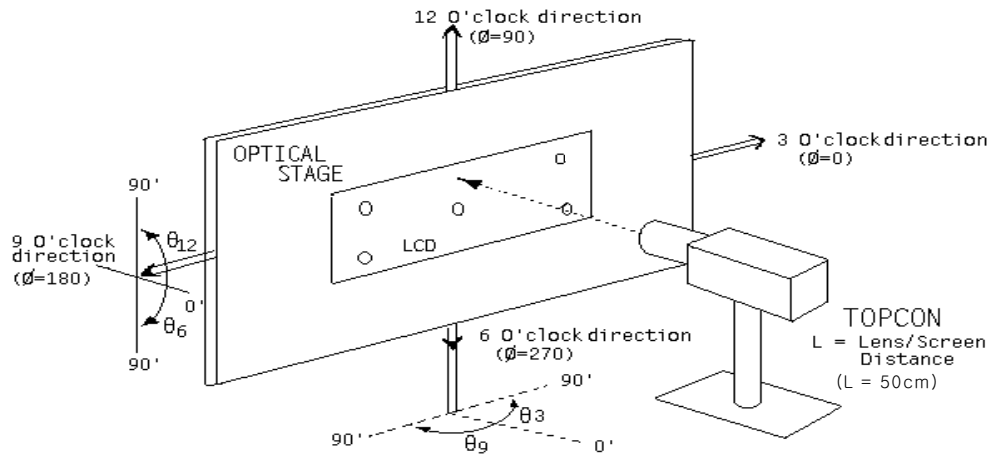

Figure 2. Average Luminance Measurement Locations & Uniformity Measurement Locations

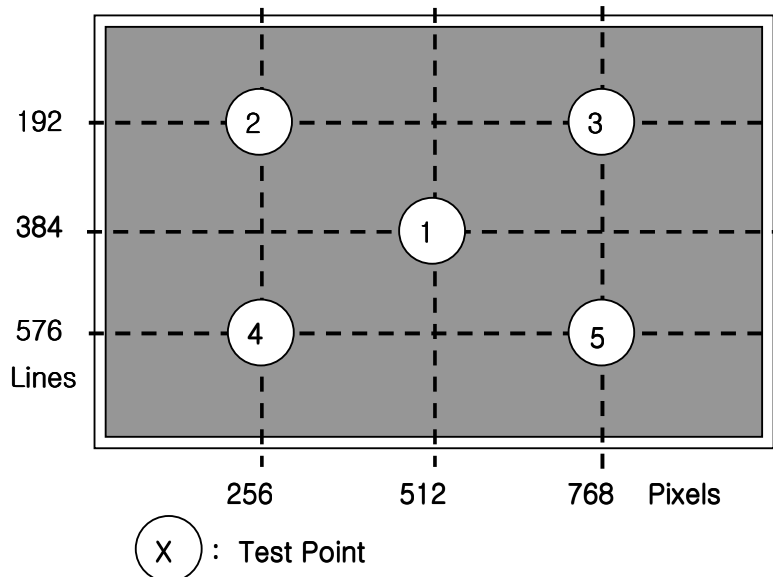
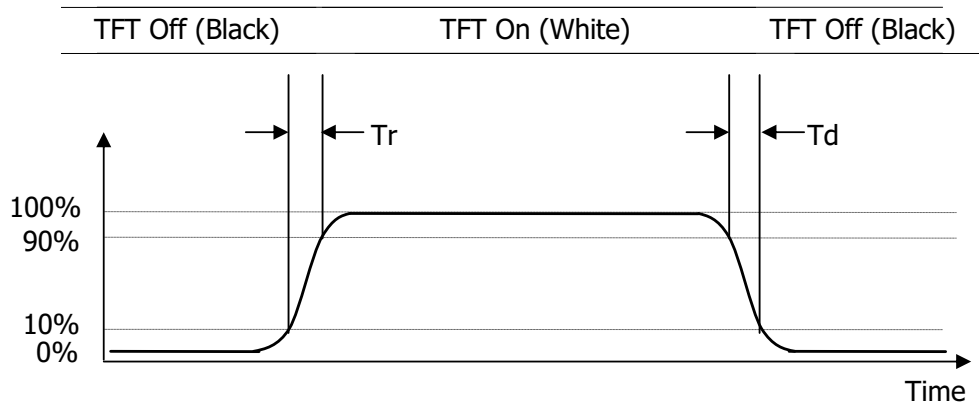
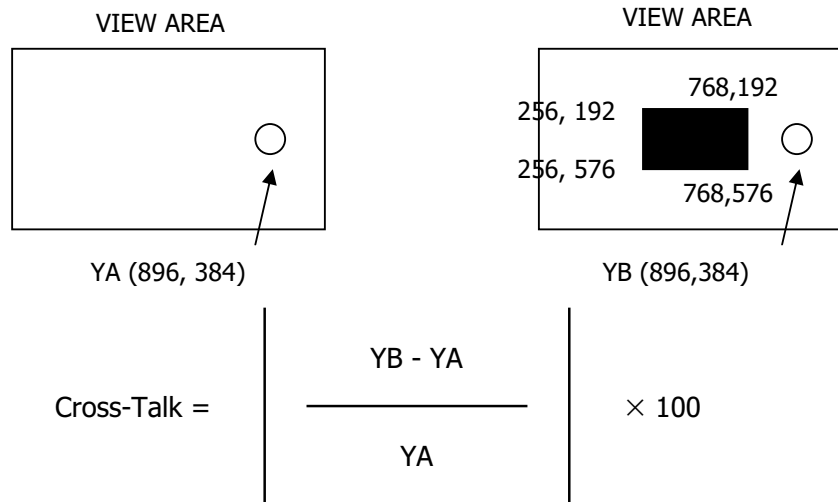

Figure 3. Response Time Testing

Figure 4. Cross Modulation Test Description

Where: Y_A = Initial luminance of measured area (cd/m²)

Y_B = Subsequent luminance of measured area (cd/m²)

The location measured will be exactly the same in both patterns.



PRODUCT GROUP
TFT-LCD PRODUCT

REV
A

ISSUE DATE
2007.11.05

Figure 5. TFT-LCD Module Outline Dimensions (Front view)

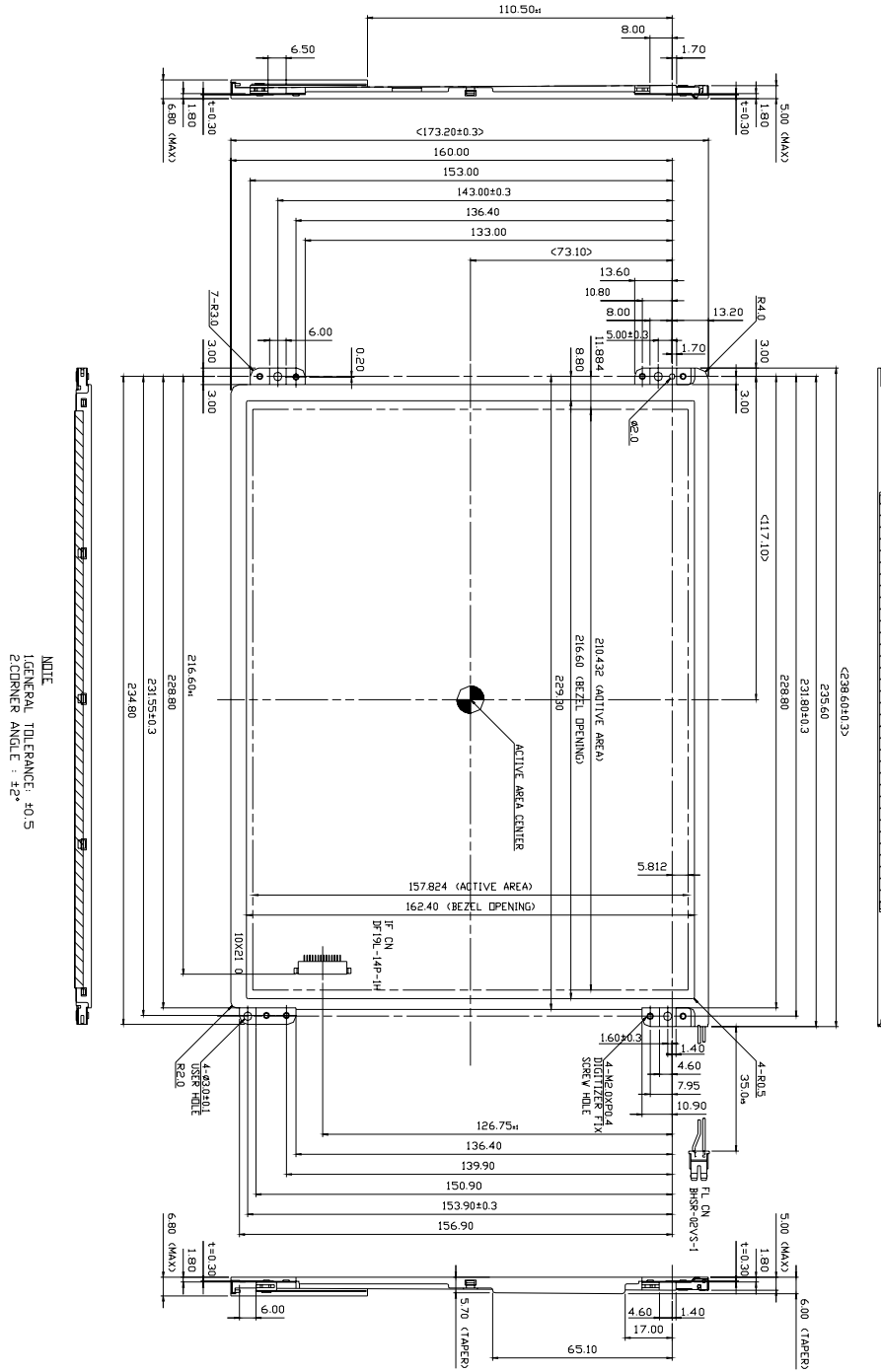

SPEC. NUMBER
S864-1331

SPEC. TITLE
HT10X21-331 Product Specification

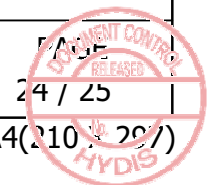

B2005-C001-C(3/3)

A4(210 x 297)



PRODUCT GROUP

REV

ISSUE DATE

TFT-LCD PRODUCT

A

2007.11.05

Figure 6. TFT-LCD Module Outline Dimensions (Rear view)

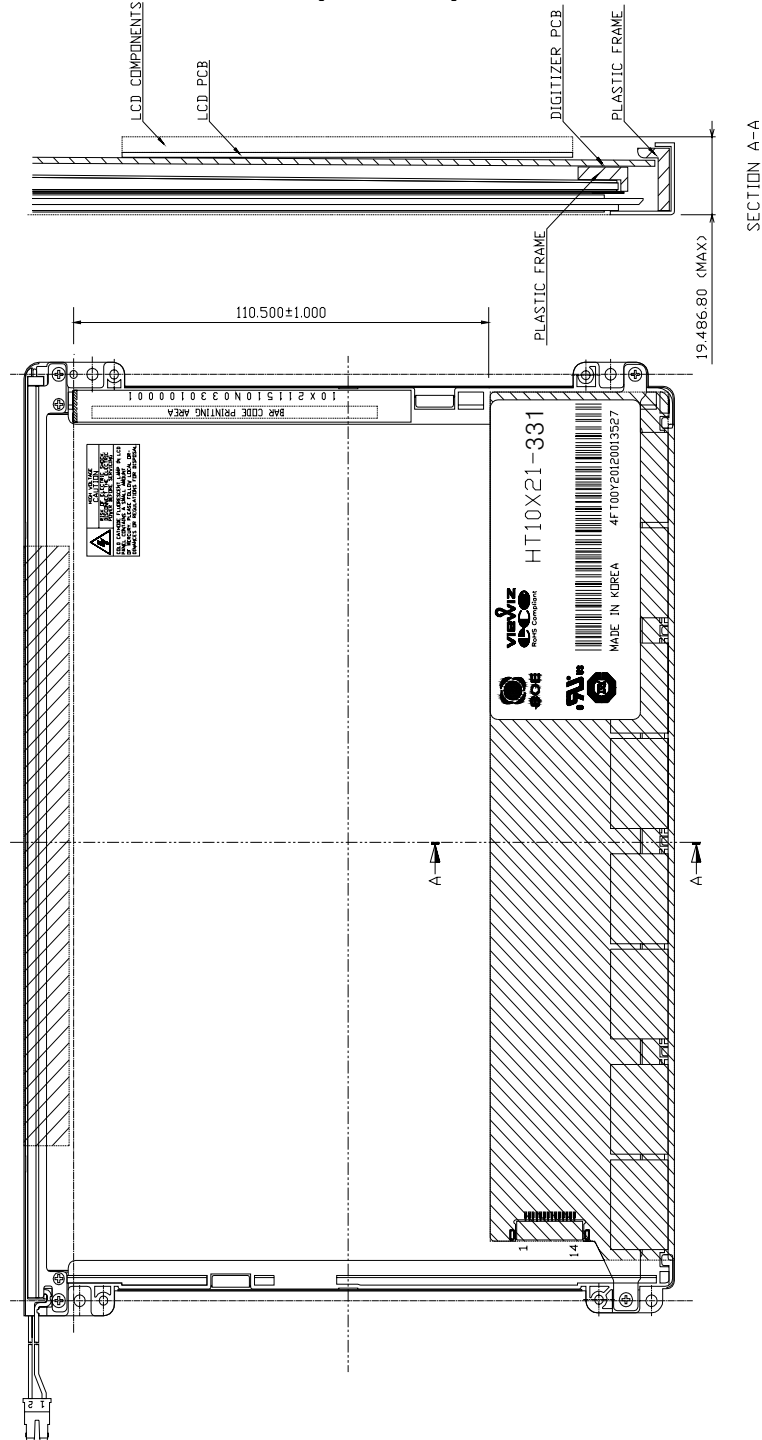

SPEC. NUMBER
S864-1331

SPEC. TITLE
HT10X21-331 Product Specification

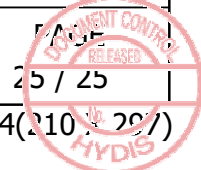

B2005-C001-C(3/3)

A4(210 x 297)