



PROPRIETARY NOTE

THIS SPECIFICATION IS THE PROPERTY OF HYDIS AND SHALL NOT BE REPRODUCED OR COPIED WITHOUT THE WRITTEN PERMISSION OF HYDIS AND MUST BE RETURNED TO HYDIS UPON ITS REQUEST.

**TITLE : HT12X12-100 Product Specification
For Sharp(POS)**

Rev. B

Hyundai Display Technology Inc.

| SPEC.NUMBER | PRODUCT GROUP | REV. | ISSUE DATE | PAGE |
|--------------------|----------------------|-------------|-------------------|-------------|
| S864 - 1083 | TFT-LCD PRODUCT | B | 2002.04.10 | 1 OF 24 |

| | | | |
|---|----------------------|-------------|-------------------|
|  | PRODUCT GROUP | REV. | ISSUE DATE |
| | TFT-LCD PRODUCT | B | 2002.04.10 |

REVISION HISTORY

| REV. | ECN NO. | DESCRIPTION OF CHANGES | DATE | PREPARED |
|------|-----------|--|------------|-----------|
| 0 | | Initial Release | 2001/11/08 | D.Y. Jang |
| A | E202-F006 | 3.1 Electrical Specifications (Page 6) I _{BL Min} : 3mA → 2mA, F _{L Min} : 50 → 40 KHz | 2002/02/23 | D.Y. Jang |
| B | E204-F003 | Power Supply Current and Power Consumption Specification Change (Page 6) I _{DD Typ.} : 300 mA → 375mA, P _{D Typ.} : 1 W → 1.24 W, P _{total Typ.} : 4 W → 4.24 W | 2002/04/10 | M.S. Park |
| | | | | |

| | | |
|------------------------------------|---|------------------------|
| SPEC. NUMBER S864 - 1083 | SPEC. TITLE HT12X12-100 Product Specification For Sharp(POS) | PAGE 2 OF 24 |
|------------------------------------|---|------------------------|

| | | | |
|---|----------------------|-------------|-------------------|
|  | PRODUCT GROUP | REV. | ISSUE DATE |
| | TFT-LCD PRODUCT | B | 2002.04.10 |

Contents

| No. | Item | Page |
|------|--|------|
| 1.0 | GENERAL DESCRIPTIONS | 4 |
| 2.0 | ABSOLUTE MAXIMUM RATINGS | 5 |
| 3.0 | ELECTRICAL SPECIFICATIONS | 6 |
| 4.0 | OPTICAL SPECIFICATIONS | 7 |
| 5.0 | INTERFACE CONNECTION | 9 |
| 6.0 | SIGNAL TIMING SPECIFICATIONS | 12 |
| 7.0 | SIGNAL TIMING WAVEFORMS | 13 |
| 8.0 | INPUT SIGNALS, DISPLAY COLORS & GRAY SCALE OF COLORS | 15 |
| 9.0 | POWER SEQUENCE | 16 |
| 10.0 | MECHANICAL CHARACTERISTICS | 17 |
| 11.0 | RELIABILITY TEST | 18 |
| 12.0 | HANDLING & CAUTIONS | 19 |
| 13.0 | PACKING INFORMATION | 19 |
| 14.0 | APPENDIX . | 20 |

| | | |
|------------------------------------|---|------------------------|
| SPEC. NUMBER S864 - 1083 | SPEC. TITLE HT12X12-100 Product Specification For Sharp(POS) | PAGE 3 OF 24 |
|------------------------------------|---|------------------------|

1.0 GENERAL DESCRIPTION

1.1 Introduction

HT12X12-100 is a color active matrix TFT LCD module using amorphous silicon TFT's (Thin Film Transistors) as an active switching devices. This module has a 12.1 inch diagonally measured active area with XGA resolutions (1024 horizontal by 768 vertical pixel array). Each pixel is divided into RED, GREEN, BLUE dots which are arranged in vertical stripe and this module can display 262,144 colors. The TFT-LCD panel used for this module is a low reflection and higher color type. Therefore, this module is suitable for notebook PC. The DC/AC inverter for back-light driving is not built in this model.

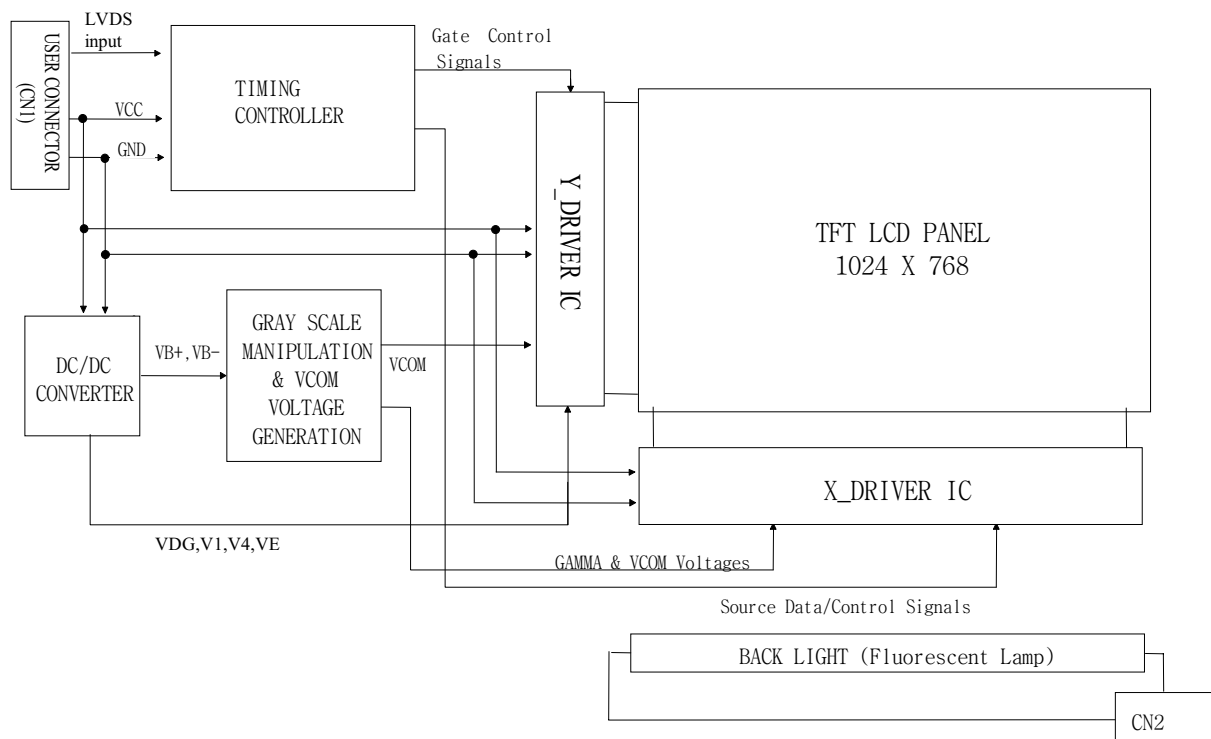

1.2 Features

- Low driving voltage and low power consumption
- Thin and light weight
- 3.3 V power supply
- 1 Channel LVDS Interface
- Single CCFL (Bottom side/Horizontal Direction)
- 262,144 colors
- Data enable signal mode
- Side Mounting Frame

| | | | |
|---|----------------------|-------------|-------------------|
|  | PRODUCT GROUP | REV. | ISSUE DATE |
| | TFT-LCD PRODUCT | B | 2002.04.10 |

1.3 General Specification

<Table 1. General Specification>

| Parameter | Specification | Unit | Remarks |
|---------------------|--|--------|---------|
| Active area | 245.8 (H) * 184.3 (V) | mm | |
| Number of pixels | 1024 (H) * 768 (V) | pixels | |
| Pixel pitch | 0.240 (H) * 0.240 (V) | mm | |
| Pixel arrangement | RGB Vertical stripe | | |
| Display colors | 262,144 | colors | |
| Display mode | Normally white | | |
| Dimensional outline | 261.0 ± 0.5 (H) * 199.0 ± 0.5 (V) * 5.2 (D) typ./ 5.5 (D) max. | mm | Note 1 |
| Weight | 380 typ., 390 max. | g | |
| Back-light | CCFL, Horizontal-lamp type | | Note 1 |

Note 1: CCFL (Cold Cathode Fluorescent Lamp)

2.0 ABSOLUTE MAXIMUM RATINGS

The followings are maximum values which, if exceed, may cause faulty operation or damage to the unit.

< Table 2. Absolute Maximum Ratings>

| Parameter | Symbol | Min. | Max. | Unit |
|-----------------------|-----------------|-------|-----------------------|------|
| Power Supply Voltage | V _{DD} | - 0.3 | + 4.6 | V |
| Logic Supply Voltage | V _{IN} | - 0.3 | V _{DD} + 0.3 | V |
| Operating Temperature | T _{OP} | 0 | + 50 | °C |
| Storage Temperature | T _{SP} | - 20 | + 60 | °C |

| | | |
|------------------------------------|---|------------------------|
| SPEC. NUMBER S864 - 1083 | SPEC. TITLE HT12X12-100 Product Specification For Sharp(POS) | PAGE 5 OF 24 |
|------------------------------------|---|------------------------|

| | | | |
|---|----------------------|-------------|-------------------|
|  | PRODUCT GROUP | REV. | ISSUE DATE |
| | TFT-LCD PRODUCT | B | 2002.04.10 |

3.0 ELECTRICAL SPECIFICATIONS

3.1 Electrical Specifications

< Table 3. Electrical specifications >

| Parameter | | Min. | Typ. | Max. | Unit | Remarks |
|---------------------------------------|--------------------|--------|--------|-------|-------------------|---------------------------|
| Power Supply Voltage | V _{DD} | 3.0 | 3.3 | 3.6 | V | Note1 |
| Power Supply Current | I _{DD} | | 375 | | mA | Note1 |
| High Level Input Differential Voltage | V _{IH} | | | +100 | mV | @V _{CM} = 1.2V |
| Low Level Input Differential Voltage | V _{IL} | -100 | | | mV | @V _{CM} = 1.2V |
| LVDS Input Common Mode Voltage | V _{CM} | 1.125 | 1.25 | 1.375 | V | |
| Back-light Lamp Voltage | V _{BL} | | 660 | | V _{rms} | Note2 |
| Back-light Lamp Current | I _{BL} | 2 | 4.5 | | mA _{rms} | |
| Back-light Lamp operating frequency | F _L | 40 | 60 | 70 | KHz | Note3 One Lamp |
| Lamp Start Voltage | | | 570 | 750 | V _{rms} | At Ta = 25°C |
| | | | 795 | 1080 | V _{rms} | At Ta = 0°C |
| Lamp Life | | 15,000 | 18,000 | | Hrs | @ I _{BL} = 4.5mA |
| Power Consumption | P _D | | 1.24 | | W | Typ. @ Color Bar |
| | P _{BL} | | 3 | | W | Note4 |
| | P _{total} | | 4.24 | | W | |

Notes :1. The supply voltage is measured and specified at the interface connector of LCM. The current draw and power consumption specified is for 3.3V at 25°C.

2. Reference value, which is measured with Samsung Electric SIC-180 Inverter. (V_{BLMIN} is value at I_{BLMIN} and V_{BLMAX} is value at I_{BLMAX})

3. The lamp frequency should be selected as different as possible from the horizontal synchronous frequency and its harmonics to avoid interference which may cause line flow on the display

4. Calculated value for reference (V_{BL} × I_{BL})

| | | |
|------------------------------------|--|------------------------|
| SPEC. NUMBER S864 - 1083 | SPEC. TITLE HT12X12-100 Product Specification For Sharp(POS) | PAGE 6 OF 24 |
|------------------------------------|--|------------------------|

4.0 OPTICAL SPECIFICATIONS

4.1 Overview

The test of optical specifications shall be measured in a dark room (ambient luminance ≤ 1 lux and temperature = $25 \pm 2^\circ\text{C}$) with the equipment of Luminance meter system (Goniometer system and TOPCONE BM-5) and test unit shall be located at an approximate distance 50cm from the LCD surface at a viewing angle of θ and ϕ equal to 0° . We refer to $\theta_{\phi=0}$ ($=\theta_3$) as the 3 o'clock direction (the "right"), $\theta_{\phi=90}$ ($=\theta_{12}$) as the 12 o'clock direction ("upward"), $\theta_{\phi=180}$ ($=\theta_9$) as the 9 o'clock direction ("left") and $\theta_{\phi=270}$ ($=\theta_6$) as the 6 o'clock direction ("bottom"). While scanning θ and/or ϕ , the center of the measuring spot on the display surface shall stay fixed. The backlight should be operating for 30 minutes prior to measurement. VDD shall be $3.3 \pm 0.15\text{V}$ at 25°C . Optimum viewing angle direction is 6 o'clock.

4.2 Optical Specifications

<Table 4. Optical Specifications>

| Parameter | | Symbol | Condition | Min. | Typ. | Max. | Unit | Remark |
|----------------------------|--------------|------------------|--|-------|-------|-------|-----------------|--------|
| Viewing Angle range | Horizontal | Θ_3 | CR > 10 | | 45 | | Deg. | Note 1 |
| | | Θ_9 | | | 45 | | Deg. | |
| | Vertical | Θ_{12} | | | 15 | | Deg. | |
| | | Θ_6 | | | 30 | | Deg. | |
| Luminance Contrast ratio | | CR | $\Theta = 0^\circ$ | | 200:1 | | | Note 2 |
| Average Luminance of white | | Y_w | $\Theta = 0^\circ$ $I_{BL} = 4.5\text{mA}$ | 110 | 130 | | cd/m^2 | Note 3 |
| White luminance uniformity | | ΔY | $I_{BL} = 4.5\text{mA}$ | | 1.17 | 1.33 | | Note 4 |
| White Chromaticity | | x_w | $\Theta = 0^\circ$ | 0.285 | 0.315 | 0.345 | | Note 5 |
| | | y_w | | 0.302 | 0.332 | 0.362 | | |
| Reproduction Of color | Red | x_R | $\Theta = 0^\circ$ | 0.541 | 0.571 | 0.601 | | |
| | | y_R | | 0.301 | 0.331 | 0.361 | | |
| | Green | x_G | | 0.279 | 0.309 | 0.339 | | |
| | | y_G | | 0.492 | 0.522 | 0.552 | | |
| | Blue | x_B | | 0.119 | 0.149 | 0.179 | | |
| | | y_B | | 0.102 | 0.132 | 0.162 | | |
| Response Time | Rise + Decay | T_r + T_d | $T_a = 25^\circ\text{C}$ $\Theta = 0^\circ$ | | 50 | | ms | Note 6 |
| Cross Talk | | CT | $\Theta = 0^\circ$ | | | 2.0 | % | Note 7 |

| | | | |
|---|----------------------|-------------|-------------------|
|  | PRODUCT GROUP | REV. | ISSUE DATE |
| | TFT-LCD PRODUCT | B | 2002.04.10 |

Note:

1. Viewing angle is the angle at which the contrast ratio is greater than 10. The viewing angles are determined for the horizontal or 3, 9 o'clock direction and the vertical or 6, 12 o'clock direction with respect to the optical axis which is normal to the LCD surface. (see FIGURE1 shown in Appendix).
2. Contrast measurements shall be made at viewing angle of $\Theta = 0^\circ$ and at the center of the LCD surface. Luminance shall be measured with all pixels in the view field set first to white, then to the dark (black) state . (see FIGURE1 shown in Appendix) Luminance Contrast Ratio (CR) is defined mathematically as $CR = \text{Luminance when displaying a white raster} / \text{Luminance when displaying a black raster}$.
3. Average Luminance of white is defined as arithmetic mean of five measurement points across the LCD surface. Luminance shall be measured with all pixels in the view field set first to white. This measurement shall be taken at the locations shown in FIGURE 2 for a total of the measurements per display.
4. The White luminance uniformity on LCD surface is then expressed as : $\Delta Y = \text{Maximum Luminance of five points} / \text{Minimum Luminance of five points}$. (see FIGURE 3).
5. The color chromaticity coordinates specified in Table 4. shall be calculated from the spectral data measured with all pixels first in red, green, blue, and white. Measurements shall be made at the center of the panel.
6. The electro-optical response time measurements shall be made as shown in FIGURE 4 (shown in Appendix)by switching the "data" input signal ON and OFF. The times needed for the luminance to change from 10% to 90% is Td and 90% to 10% is Tr.
7. Cross-Talk of one area of the LCD surface by another shall be measured by comparing the luminance (YA) of a 25mm diameter area, with all display pixels set to a gray level, to the luminance (YB) of that same area when any adjacent area is driven dark (Refer to FIGURE 5).

| | | |
|------------------------------------|--|------------------------|
| SPEC. NUMBER S864 - 1083 | SPEC. TITLE HT12X12-100 Product Specification For Sharp(POS) | PAGE 8 OF 24 |
|------------------------------------|--|------------------------|

5.0 INTERFACE CONNECTION

5.1 Electrical Interface Connection

The electronics interface connector is a model DF19L-20P-1H manufactured by Hirose or equivalent.

<Table 5. Pin Assignment for the Interface Connector>

| Terminal NO. | Symbol | Function |
|---------------------|---------------|-----------------------------------|
| 1 | VDD1 | Power Supply : +3.3V |
| 2 | VDD2 | Power Supply : +3.3V |
| 3 | VSS1 | Ground |
| 4 | VSS2 | Ground |
| 5 | RIN0- | Transmission Data of 0 Negative - |
| 6 | RIN0+ | Transmission Data of 0 Positive + |
| 7 | VSS3 | Ground |
| 8 | RIN1- | Transmission Data of 1 Negative - |
| 9 | RIN1+ | Transmission Data of 1 Positive + |
| 10 | VSS4 | Ground |
| 11 | RIN2- | Transmission Data of 2 Negative - |
| 12 | RIN2+ | Transmission Data of 2 Positive + |
| 13 | VSS5 | Ground |
| 14 | RCLK- | Sampling Clock of Negative - |
| 15 | RCLK+ | Sampling Clock of Positive + |
| 16 | VSS6 | Ground |
| 17 | NC1 | No Connection |
| 18 | NC2 | No Connection |
| 19 | NC3 | No Connection |
| 20 | NC4 | No Connection |

5.2 LVDS Interface

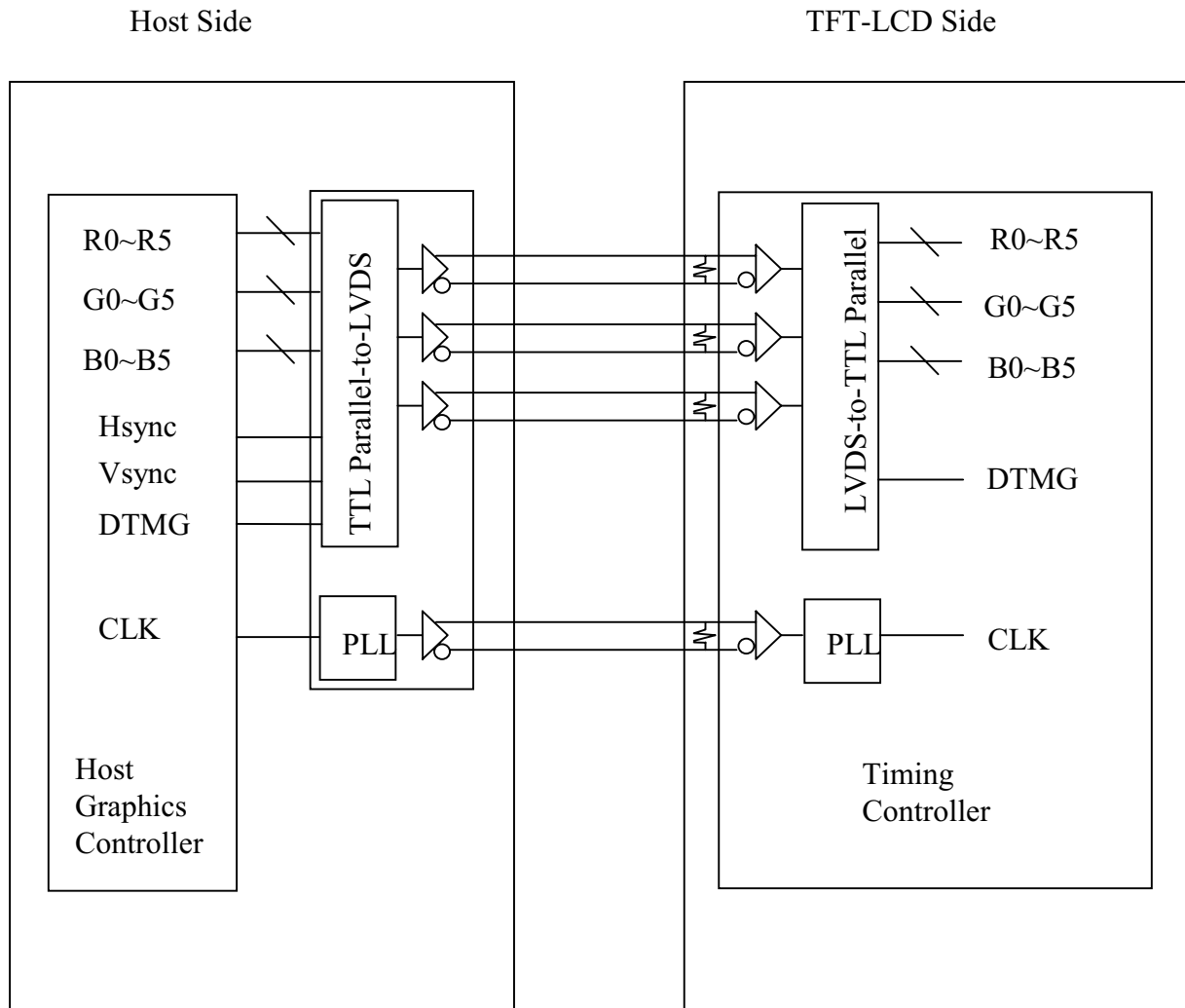

NOTE : 1) LVDS cable impedance is 100 ohms per signal line when two are used differentially.

2) Transmitter : TI SN75LVDS84, or equivalent.
Transmitter is not contained in Module.

5.3 LVDS Input signal

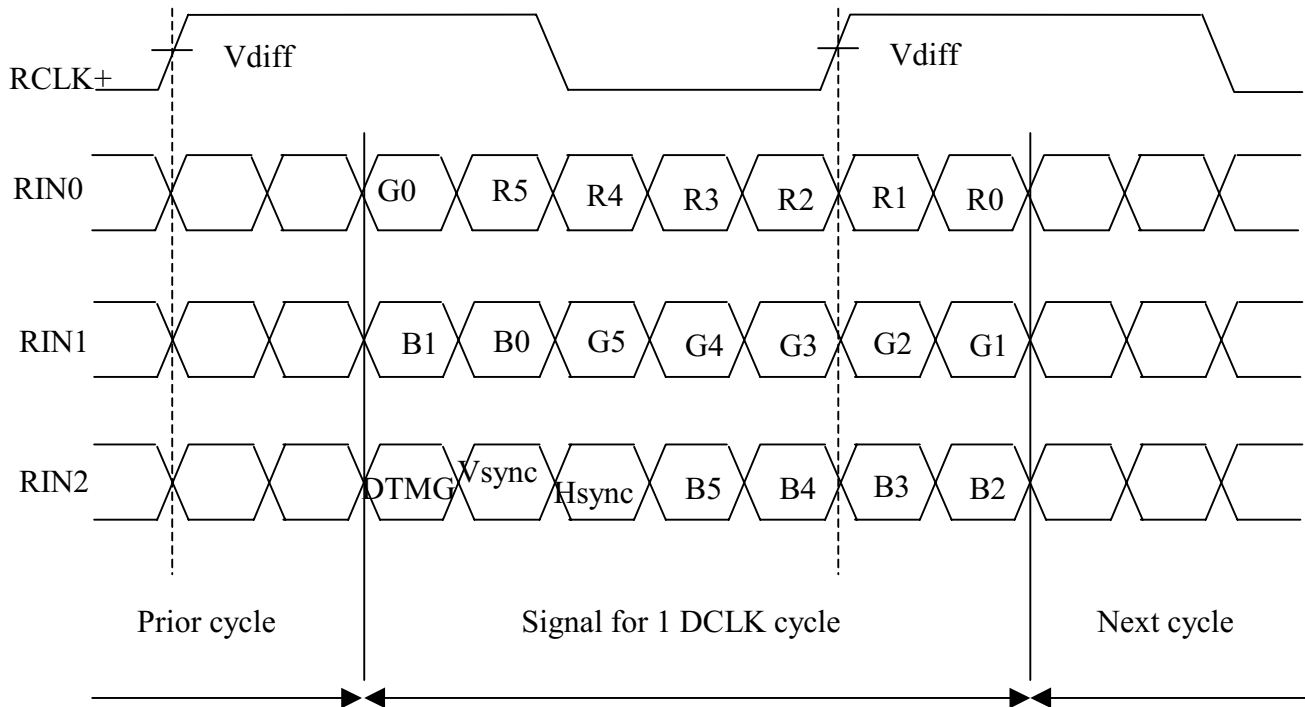

<Table 6. Pin connection in case of using TI SN75LVDS84 >

| Input signal | Transmitter | Input signal | Transmitter |
|--------------|-------------|--------------|-------------|
| DCLK | CLK IN(26) | G4 | IN10(10) |
| R0 | IN0(44) | G5 | IN11(12) |
| R1 | IN1(45) | B0 | IN12(13) |
| R2 | IN2(47) | B1 | IN13(15) |
| R3 | IN3(48) | B2 | IN14(16) |
| R4 | IN4(1) | B3 | IN15(18) |
| R5 | IN5(3) | B4 | IN16(19) |
| G0 | IN6(4) | B5 | IN17(20) |
| G1 | IN7(6) | Hsync | IN18(22) |
| G2 | IN8(7) | Vsync | IN19(23) |
| G3 | IN9(9) | DTMG | IN20(25) |

| | | | |
|---|----------------------|-------------|-------------------|
|  | PRODUCT GROUP | REV. | ISSUE DATE |
| | TFT-LCD PRODUCT | B | 2002.04.10 |

5.4 BACK-LIGHT INTERFACE

The Back-light interface connector is a model BHSR-02VS-1 manufactured by JST or equivalent.

<Table 8. Back-light Electrical Interface>

| Terminal No. | Symbol | Function |
|--------------|--------|----------------------------------|
| 1 | VL | CCFL Power Supply (High Voltage) |
| 2 | GL | CCFL Power Supply (GND Side) |

6.0 SIGNAL TIMING SPECIFICATION

<Table 9. Signal Timing Specification.>

| ITEM | SYMBOL | Min. | Typ. | Max. | Unit | Remarks |
|-------------------------|--------|-----------|-----------|-----------|------|-----------|
| Frame Period | t1 | 801 × t3 | 806 × t3 | 812 × t3 | -- | 60 Hz |
| | | | 16.67 | | ms | |
| Vertical Display Term | t2 | 768 × t3 | 768 × t3 | 768 × t3 | -- | |
| | | | 15.88 | | ms | |
| One Line Scanning Time | t3 | 1280 × t5 | 1344 × t5 | 1364 × t5 | -- | 48.38 kHz |
| | | | 20.67 | | us | |
| Horizontal Display Term | t4 | 1024 × t5 | 1024 × t5 | 1024 × t5 | -- | |
| | | | 15.75 | | us | |
| Clock Period | t5 | 14.00 | 15.38 | | ns | 65 MHz |

| | | |
|------------------------------------|--|-------------------------|
| SPEC. NUMBER S864 - 1083 | SPEC. TITLE HT12X12-100 Product Specification For Sharp(POS) | PAGE 12 OF 24 |
|------------------------------------|--|-------------------------|

7.0 SIGNAL TIMING WAVEFORMS

7.1 Vertical Timing Waveforms

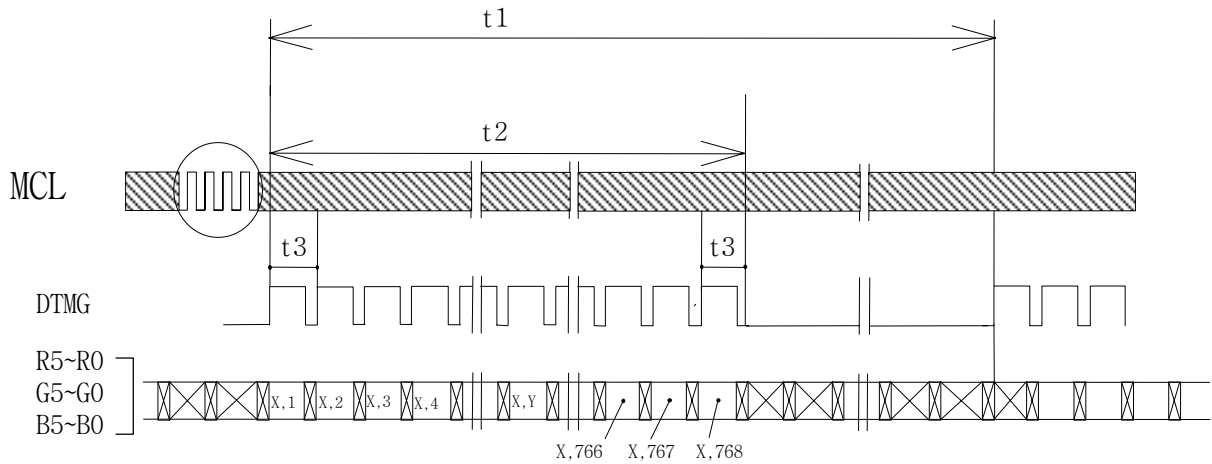

7.2 Horizontal Timing Waveforms

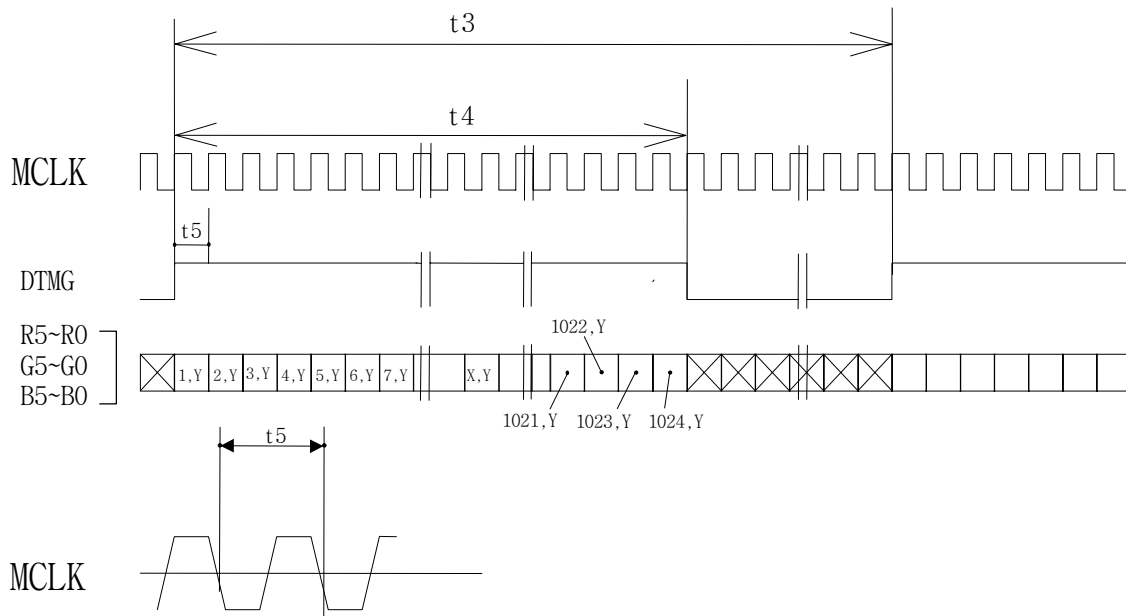

7.3 LVDS Rx Interface Timing Parameter

<Table 10. LVDS Rx Interface Timing Specification>

| Item | Symbol | Min | Typ | Max | Unit | Remark |
|--------------|--------|--------------------------|--------------------|--------------------------|------|--------|
| PLL Set | tRPLL | - | - | 10.0 | msec | |
| RCLK Period | tRCIP | | 15.38 | | nsec | |
| Input Data 0 | tRIP1 | -0.4 | 0.0 | +0.4 | nsec | |
| Input Data 1 | tRIP0 | $tRCIP/7 - 0.4$ | $tRCIP/7$ | $tRCIP/7 + 0.4$ | nsec | |
| Input Data 2 | tRIP6 | $2 \times tRCIP/7 - 0.4$ | $2 \times tRCIP/7$ | $2 \times tRCIP/7 + 0.4$ | nsec | |
| Input Data 3 | tRIP5 | $3 \times tRCIP/7 - 0.4$ | $3 \times tRCIP/7$ | $3 \times tRCIP/7 + 0.4$ | nsec | |
| Input Data 4 | tRIP4 | $4 \times tRCIP/7 - 0.4$ | $4 \times tRCIP/7$ | $4 \times tRCIP/7 + 0.4$ | nsec | |
| Input Data 5 | tRIP3 | $5 \times tRCIP/7 - 0.4$ | $5 \times tRCIP/7$ | $5 \times tRCIP/7 + 0.4$ | nsec | |
| Input Data 6 | tRIP2 | $6 \times tRCIP/7 - 0.4$ | $6 \times tRCIP/7$ | $6 \times tRCIP/7 + 0.4$ | nsec | |

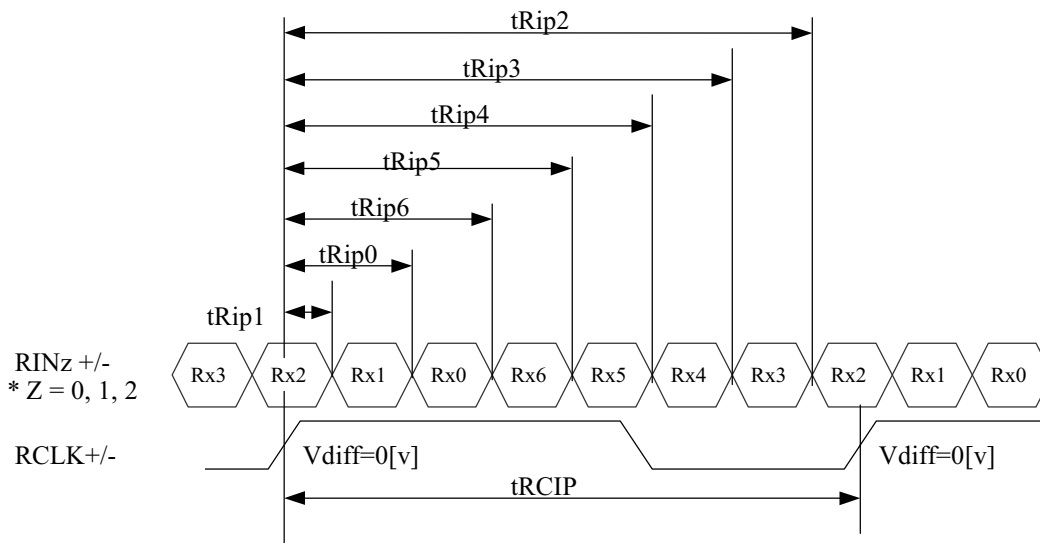

8.0 INPUT SIGNALS, BASIC DISPLAY COLORS & GRAY SCALE OF COLORS

Each color is displayed in sixty-four gray scales from a 6 bit data signal input. A total of 262,144 colors are derived from the resultant 18 bit data.

<Table 11. Input signals, Basic display colors and Gray scale of colors.>

| Colors & Gray Scale | | Data Signal | | | | | | | | | | | |
|-----------------------------|-------------|-------------------|-------------------|-------------------|--|--|--|--|--|--|--|--|--|
| | | R0 R1 R2 R3 R4 R5 | G0 G1 G2 G3 G4 G5 | B0 B1 B2 B3 B4 B5 | | | | | | | | | |
| Basic Colors | Black | 0 0 0 0 0 0 | 0 0 0 0 0 0 | 0 0 0 0 0 0 | | | | | | | | | |
| | Blue | 0 0 0 0 0 0 | 0 0 0 0 0 0 | 1 1 1 1 1 1 | | | | | | | | | |
| | Green | 0 0 0 0 0 0 | 1 1 1 1 1 1 | 0 0 0 0 0 0 | | | | | | | | | |
| | Light Blue | 0 0 0 0 0 0 | 1 1 1 1 1 1 | 1 1 1 1 1 1 | | | | | | | | | |
| | Red | 1 1 1 1 1 1 | 0 0 0 0 0 0 | 0 0 0 0 0 0 | | | | | | | | | |
| | Purple | 1 1 1 1 1 1 | 0 0 0 0 0 0 | 1 1 1 1 1 1 | | | | | | | | | |
| | Yellow | 1 1 1 1 1 1 | 1 1 1 1 1 1 | 0 0 0 0 0 0 | | | | | | | | | |
| Gray Scale of Red | White | 1 1 1 1 1 1 | 1 1 1 1 1 1 | 1 1 1 1 1 1 | | | | | | | | | |
| | Black | 0 0 0 0 0 0 | 0 0 0 0 0 0 | 0 0 0 0 0 0 | | | | | | | | | |
| | △ | 1 0 0 0 0 0 | 0 0 0 0 0 0 | 0 0 0 0 0 0 | | | | | | | | | |
| | Darker | 0 1 0 0 0 0 | 0 0 0 0 0 0 | 0 0 0 0 0 0 | | | | | | | | | |
| | △ | | | | | | | | | | | | |
| | ▽ | | | | | | | | | | | | |
| | Brighter | 1 0 1 1 1 1 | 0 0 0 0 0 0 | 0 0 0 0 0 0 | | | | | | | | | |
| Gray Scale of Green | Red | 1 1 1 1 1 1 | 0 0 0 0 0 0 | 0 0 0 0 0 0 | | | | | | | | | |
| | Black | 0 0 0 0 0 0 | 0 0 0 0 0 0 | 0 0 0 0 0 0 | | | | | | | | | |
| | △ | 0 0 0 0 0 0 | 1 0 0 0 0 0 | 0 0 0 0 0 0 | | | | | | | | | |
| | Darker | 0 0 0 0 0 0 | 0 1 0 0 0 0 | 0 0 0 0 0 0 | | | | | | | | | |
| | △ | | | | | | | | | | | | |
| | ▽ | | | | | | | | | | | | |
| | Brighter | 0 0 0 0 0 0 | 1 0 1 1 1 1 | 0 0 0 0 0 0 | | | | | | | | | |
| Gray Scale of Blue | Green | 0 0 0 0 0 0 | 1 1 1 1 1 1 | 0 0 0 0 0 0 | | | | | | | | | |
| | Black | 0 0 0 0 0 0 | 0 0 0 0 0 0 | 0 0 0 0 0 0 | | | | | | | | | |
| | △ | 0 0 0 0 0 0 | 0 0 0 0 0 0 | 1 0 0 0 0 0 | | | | | | | | | |
| | Darker | 0 0 0 0 0 0 | 0 0 0 0 0 0 | 0 1 0 0 0 0 | | | | | | | | | |
| | △ | | | | | | | | | | | | |
| | ▽ | | | | | | | | | | | | |
| | Brighter | 0 0 0 0 0 0 | 0 0 0 0 0 0 | 1 0 1 1 1 1 | | | | | | | | | |
| Gray Scale of White & Black | Blue | 0 0 0 0 0 0 | 0 0 0 0 0 0 | 1 1 1 1 1 1 | | | | | | | | | |
| | Black | 0 0 0 0 0 0 | 0 0 0 0 0 0 | 0 0 0 0 0 0 | | | | | | | | | |
| | △ | 1 0 0 0 0 0 | 1 0 0 0 0 0 | 1 0 0 0 0 0 | | | | | | | | | |
| | Darker | 0 1 0 0 0 0 | 0 1 0 0 0 0 | 0 1 0 0 0 0 | | | | | | | | | |
| | △ | | | | | | | | | | | | |
| | ▽ | | | | | | | | | | | | |
| | Brighter | 1 0 1 1 1 1 | 1 0 1 1 1 1 | 1 0 1 1 1 1 | | | | | | | | | |
| White | 1 1 1 1 1 1 | 1 1 1 1 1 1 | 1 1 1 1 1 1 | | | | | | | | | | |

9.0 POWER SEQUENCE

To prevent a latch-up or DC operation of the LCD module, the power on/off sequence shall be as shown in below

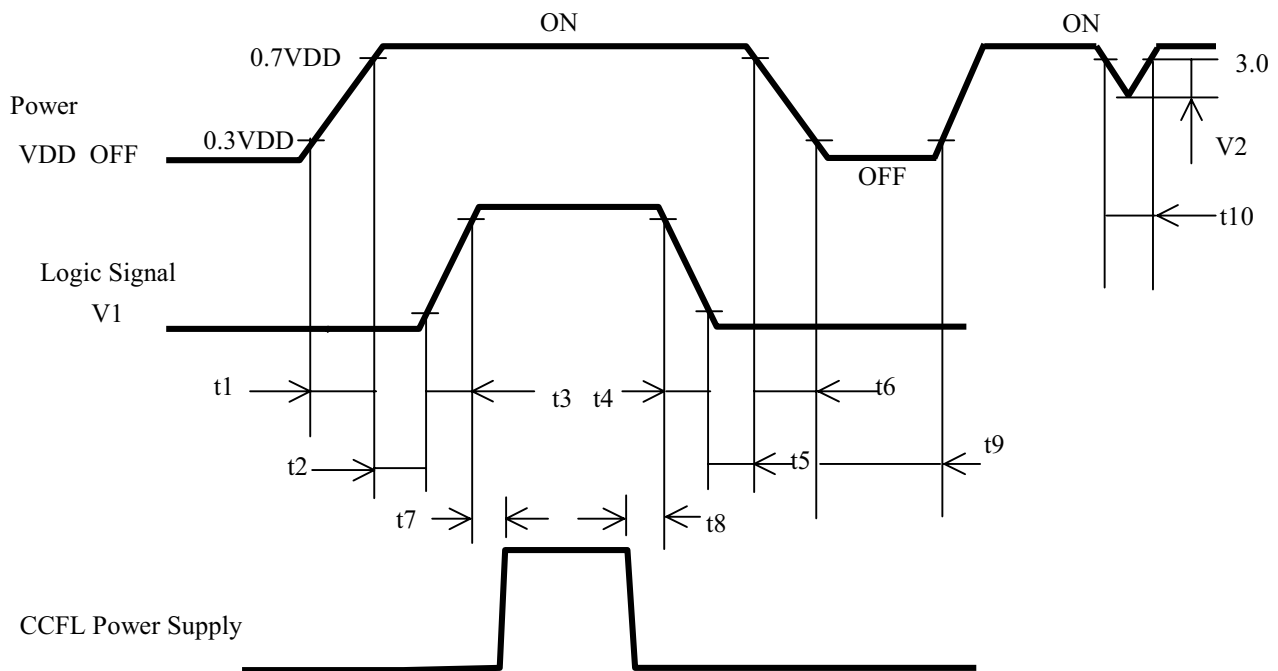

$$\begin{array}{ll}
 t1 \leq 10 \text{ ms} & 0 \leq t4 \leq 50 \text{ ms} \\
 0 \leq t2 \leq 50 \text{ ms} & 0 \leq t5 \leq 50 \text{ ms} \\
 0 \leq t3 \leq 50 \text{ ms} & t6 \leq 10 \text{ ms} \\
 t7 \geq 100 \text{ ms} & t8 \geq 200 \text{ ms} \\
 t9 \geq 1 \text{ s} & t10 \leq 10 \text{ ms (Note2.)}
 \end{array}$$

$$2.4 \text{ V} \leq V2 \leq 3.0 \text{ V (Note3.)}$$

* SET $0\text{V} \leq V1(t) \leq VDD(t)$

HERE, $V1(t)$, $VDD(t)$ indicate the transitive state of $V1$, VDD when the power supply is turned ON or OFF

Note1. : Do not keep the interface signal high-impedance when power is on.

Note2. : Momentary Voltage Drop Time.

Note3. : Momentary Drop Voltage.

| | | | |
|---|----------------------|-------------|-------------------|
|  | PRODUCT GROUP | REV. | ISSUE DATE |
| | TFT-LCD PRODUCT | B | 2002.04.10 |

10.0 MECHANICAL CHARACTERISTICS

10.1 Dimensional Requirements

<Table 12. Dimensional Parameters.>

| Parameter | Specification | Unit |
|---------------------|---|--------|
| Active area | 245.8 (H) * 184.3 (V) | mm |
| Number of pixels | 1024 (H) * 768 (V) | pixels |
| | (1 pixel = R + G + B dots) | |
| Pixel pitch | 0.240 (H) * 0.240 (V) | mm |
| Pixel arrangement | RGB Vertical stripe | |
| Display colors | 262,144 | colors |
| Display mode | Normally white | |
| Dimensional outline | 261.0 ± 0.5(H) * 199.0 ± 0.5(V) * 5.2 (D) typ. / 5.5 (D) max. | mm |
| Weight | 380 Typ., 390 max. | gram |
| Back-light | CCFL, Horizontal-lamp type | |

See FIGURE 6. (shown in Appendix)

10.2 Mounting

See FIGURE 7. (shown in Appendix)

10.3 Anti-Glare and Polarizer Hardness.

The surface of the LCD has an anti-glare coating to minimize reflection and a coating to reduce scratching.

10.4 Light Leakage

There shall not be visible light from the back-lighting system around the edges of the screen as seen from a distance 50cm from the screen with an overhead light level of 350lux.

| | | |
|------------------------------------|---|-------------------------|
| SPEC. NUMBER S864 - 1083 | SPEC. TITLE HT12X12-100 Product Specification For Sharp(POS) | PAGE 17 OF 24 |
|------------------------------------|---|-------------------------|

11.0 RELIABILITY TEST

<Table 13. Reliability test>

| No | Test Items | Conditions |
|----|---|---|
| 1 | High temperature storage test | Ta = 60 °C, 240 hrs |
| 2 | Low temperature storage test | Ta = -20 °C, 240 hrs |
| 3 | High temperature & high humidity operation test | Ta = 50 °C, 80 %RH, 240 hrs |
| 4 | High temperature operation test | Ta = 50 °C, 240 hrs |
| 5 | Low temperature operation test | Ta = 0 °C, 240 hrs |
| 6 | Thermal shock | Ta = -20 °C ↔ 60 °C (0.5 hr), 100 cycle |
| 7 | Vibration test (non-operating) | Frequency : 10 ~ 500 Hz Gravity/AMP : 1.5G X,Y,Z Period : 30 min |
| 8 | Shock test (non-operating) | Gravity : 220 G Pulse width : 2 ms, half sine wave Direction : ±X, ±Y, ±Z twice for each direction |
| 9 | Electrostatic discharge test | Air : 150 pF, 330Ω, 15 KV Contact : 150 pF, 330Ω, 8 KV |

Result Evaluation Criteria

Under the display quality test conditions with normal operation state, there shall be no change which may affect practical display function.

| | | | |
|---|----------------------|-------------|-------------------|
|  | PRODUCT GROUP | REV. | ISSUE DATE |
| | TFT-LCD PRODUCT | B | 2002.04.10 |

12.0 HANDLING & CAUTIONS

(1) Cautions when taking out the module

- Pick the pouch only, when taking out module from a shipping package.

(2) Cautions for handling the module

- As the electrostatic discharges may break the LCD module, handle the LCD module with care. Peel a protection sheet off from the LCD panel surface as slowly as possible.
- As the LCD panel and back - light element are made from fragile glass material, impulse and pressure to the LCD module should be avoided.
- As the surface of the polarizer is very soft and easily scratched, use a soft dry cloth without chemicals for cleaning.
- Do not pull the interface connector in or out while the LCD module is operating.
- Put the module display side down on a flat horizontal plane.
- Handle connectors and cables with care.

(3) Cautions for the operation

- When the module is operating, do not lose CLK, ENAB signals. If any one of these signals is lost, the LCD panel would be damaged.
- Obey the supply voltage sequence. If wrong sequence is applied, the module would be damaged.

(4) Cautions for the atmosphere

- Dew drop atmosphere should be avoided.
- Do not store and/or operate the LCD module in a high temperature and/or humidity atmosphere. Storage in an electro-conductive polymer packing pouch and under relatively low temperature atmosphere is recommended.

(5) Cautions for the module characteristics

- Do not apply fixed pattern data signal to the LCD module at product aging.
- Applying fixed pattern for a long time may cause image sticking.

(6) Other cautions

- Do not disassemble and/or re-assemble LCD module.
- Do not re-adjust variable resistor or switch etc.
- When returning the module for repair or etc., Please pack the module not to be broken. We recommend to use the original shipping packages.

13.0 PACKING INFORMATION

HEI provides the standard shipping container for customers, unless customer specifies their packing information. (TBD)

| | | |
|------------------------------------|---|-------------------------|
| SPEC. NUMBER S864 - 1083 | SPEC. TITLE HT12X12-100 Product Specification For Sharp(POS) | PAGE 19 OF 24 |
|------------------------------------|---|-------------------------|

14.0 APPENDIX

Figure 1. Measurement Set Up

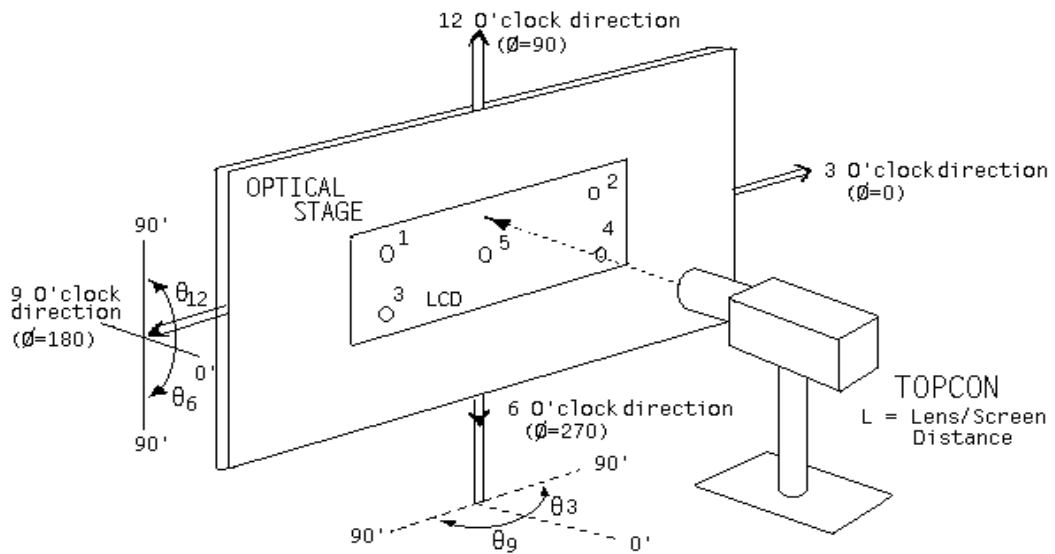

Figure 2. Average Luminance Measurement Locations

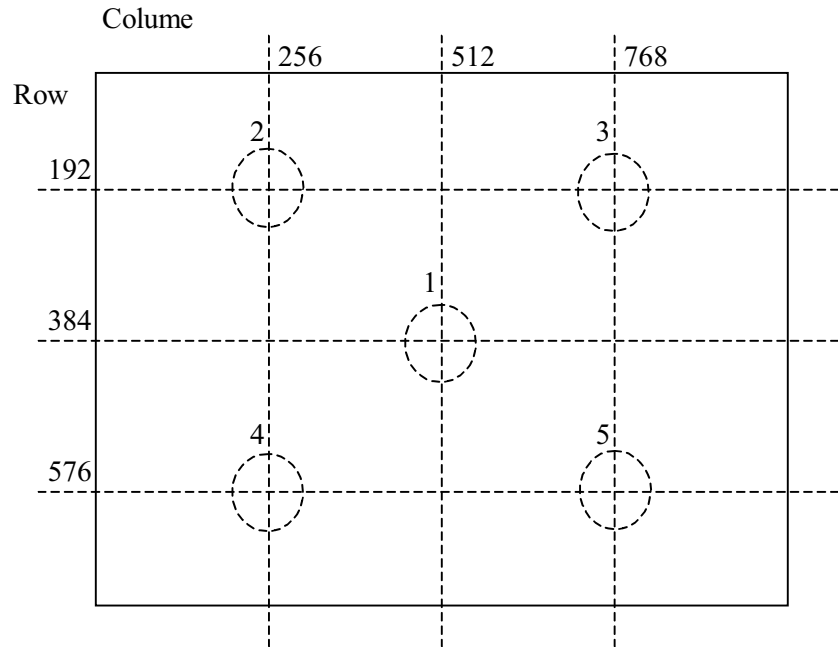

Figure 3. Uniformity Measurement Locations

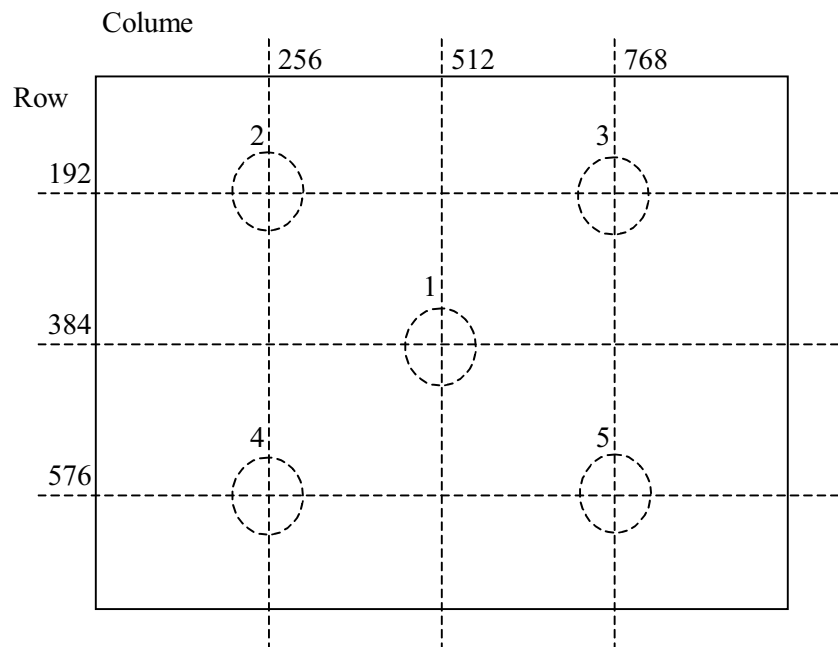
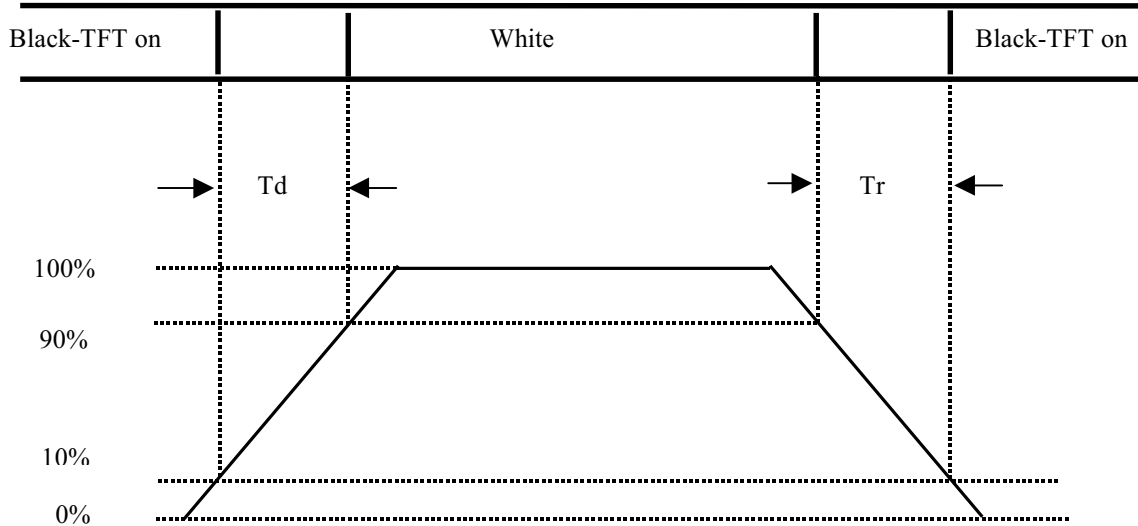
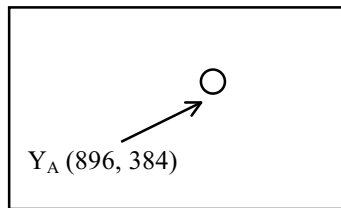
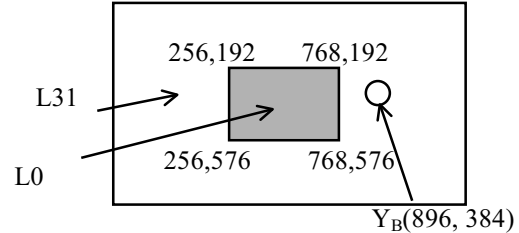

Figure 4. Response Time Testing

Figure 5. Cross Modulation Test Description

VIEW AREA



VIEW AREA



$$\text{Cross-Talk(\%)} = \left| \frac{Y_B - Y_A}{Y_B} \right| \times 100$$

Where:

 $Y_A = \text{Initial luminance of measured area (cd/m}^2\text{)}$
 $Y_B = \text{Subsequent luminance of measured area (cd/m}^2\text{)}$

The location measured will be exactly the same in both patterns

Figure 6. TFT-LCD Module Outline Dimensions (Front view)

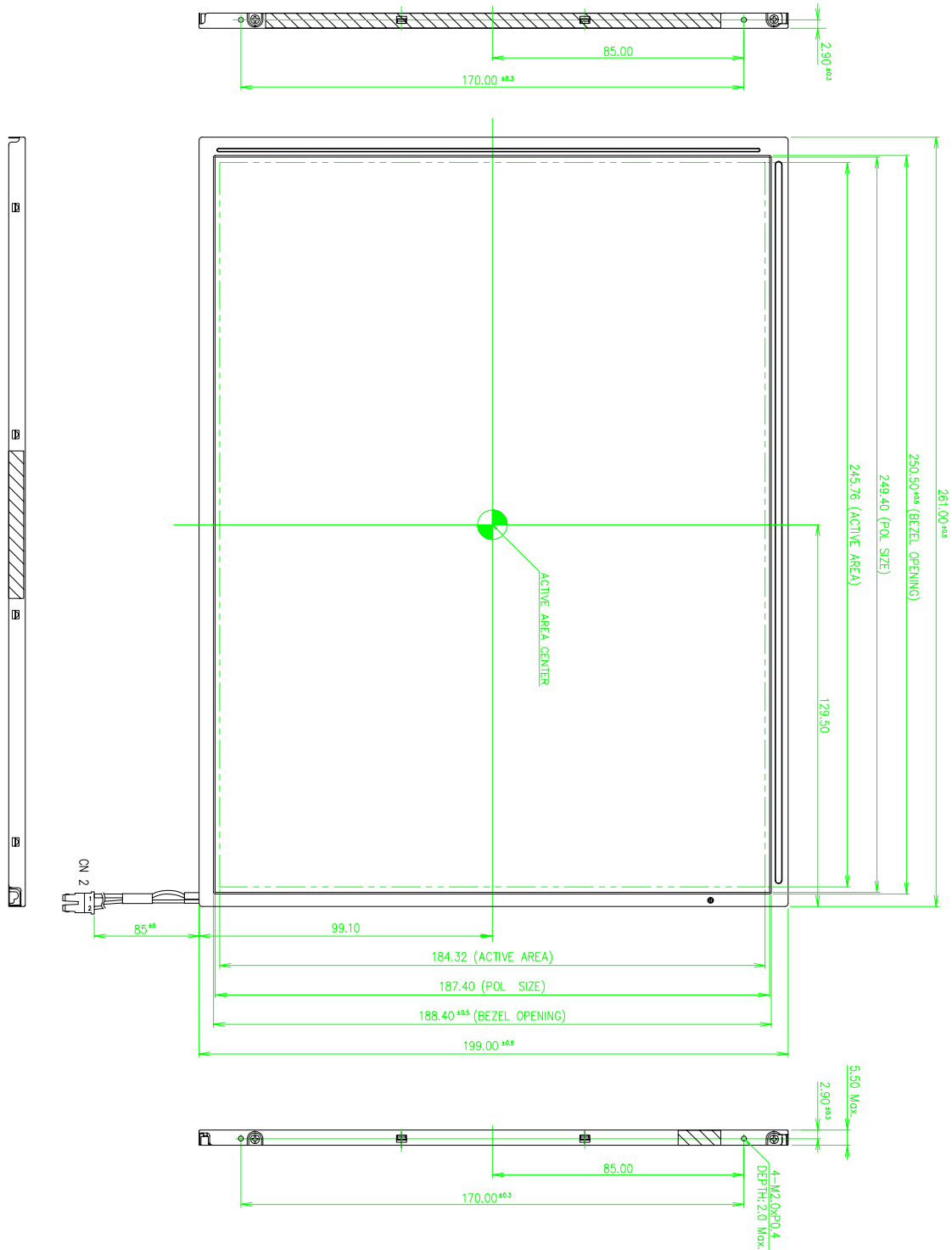
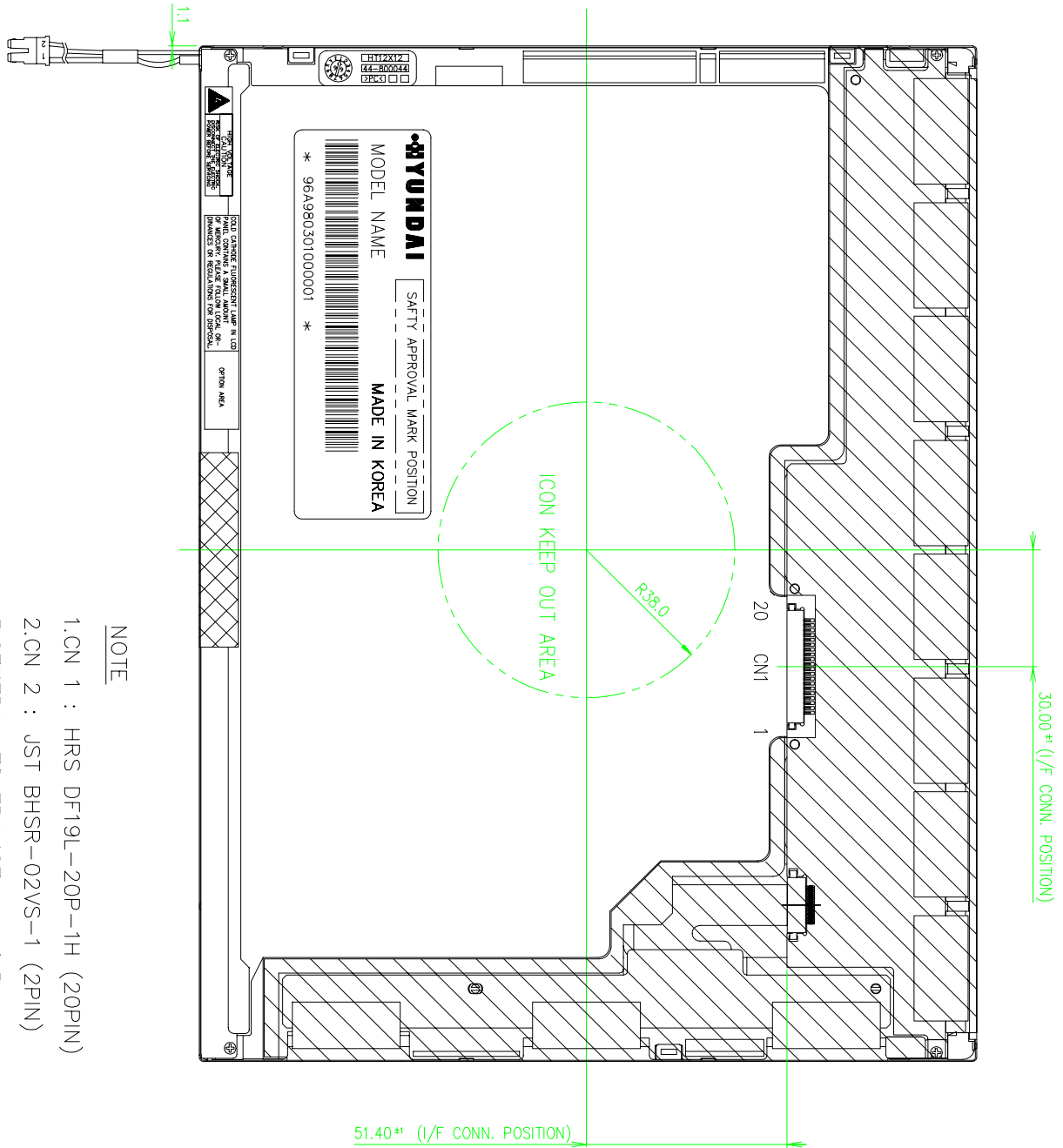

Figure 7. TFT-LCD Module Outline Dimensions (Back view)



NOTE

- 1. CN 1 : HRS DF19L-20P-1H (20PIN)
- 2. CN 2 : JST BHSR-02VS-1 (2PIN)
- 3. GENERAL TOLERANCE : ± 0.5