



PROPRIETARY NOTE
THIS SPECIFICATION IS THE PROPERTY OF BOE OT AND SHALL NOT BE REPRODUCED OR COPIED WITHOUT THE WRITTEN PERMISSION OF BOE OT AND MUST BE RETURNED TO BOE OT UPON ITS REQUEST

TITLE : HT140WXB-100
Product Specification
Rev.0

BEIJING BOE OPTOELECTRONICS TECHNOLOGY

| | | | | |
|-------------------|--------------------------|-----------|--------------------------|-----------------|
| SPEC. NUMBER S | PRODUCT GROUP TFT-LCD | REV. 0 | ISSUE DATE 2009.6.27. | PAGE 1 OF 35 |
|-------------------|--------------------------|-----------|--------------------------|-----------------|

**PRODUCT GROUP**

REV

ISSUE DATE

TFT LCD PRODUCT

0

2009.6.27.

Contents

| No. | Items | Page |
|------|--|------|
| 1.0 | General Description | 4 |
| 2.0 | Absolute Maximum ratings | 6 |
| 3.0 | Electrical specifications. | 7 |
| 4.0 | Optical specifications. | 9 |
| 5.0 | Interface Connection | 14 |
| 6.0 | Signal Timing Specification | 18 |
| 7.0 | Signal Timing waveforms | 20 |
| 8.0 | Input Signals, Display Colors & Gray Scale of Colors | 22 |
| 9.0 | Power Sequence | 23 |
| 10.0 | Connector description | 24 |
| 11.0 | Mechanical Characteristics | 25 |
| 12.0 | Reliability Test | 26 |
| 13.0 | Handling & Cautions. | 26 |
| 14.0 | Label | 27 |
| 15.0 | Packing information | 29 |
| 16.0 | Mechanical Outline Dimension | 30 |
| 17.0 | EDID Table | 32 |

SPEC. NUMBER
SSPEC TITLE
HT140WXB-100 Product SpecificationPAGE
3 OF 35

1.0 GENERAL DESCRIPTION

1.1 Introduction

HT140WXB-100 is a color active matrix TFT LCD module using amorphous silicon TFT's (Thin Film Transistors) as an active switching devices. This module has a 14.0 inch diagonally measured active area with WXGA resolutions (1366 horizontal by 768 vertical pixel array). Each pixel is divided into RED, GREEN, BLUE dots which are arranged in vertical Stripe and this module can display 262,144 colors. The TFT-LCD panel used for this module is a low reflection and higher color type. Therefore, this module is suitable for Notebook PC. The LED Driver for back-light driving is built in this model. All input signals are LVDS interface compatible.

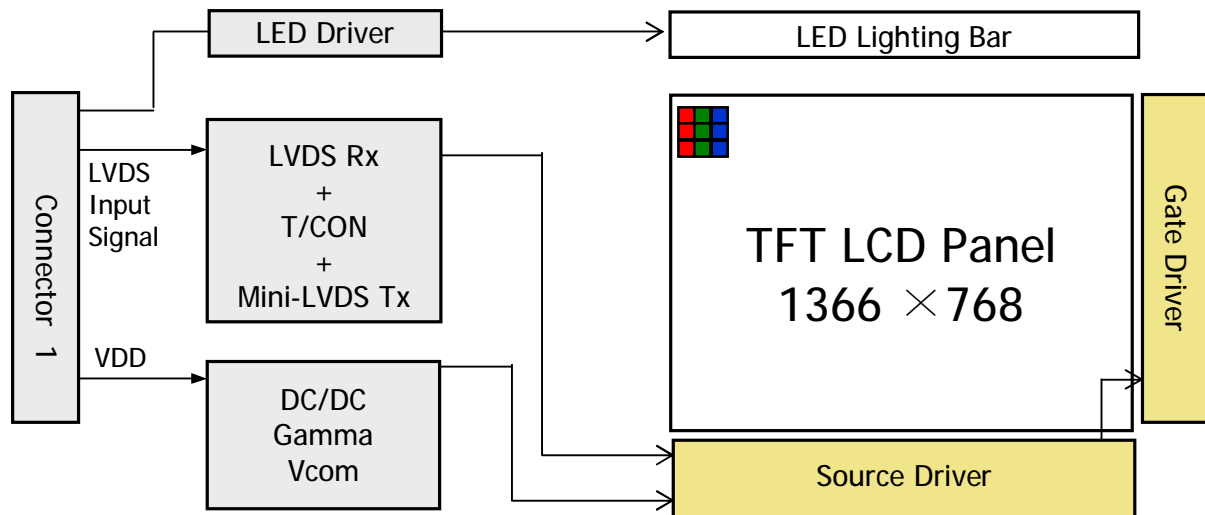

1.2 Features

- I 1 Channel LVDS Interface with 1 pixel / clock
- I Thin and light weight
- I 6-bit color depth, display 262K colors
- I Single LED Lighting Bar. (Top side/Horizontal Direction)
- I Data enable signal mode
- I Side Mounting Frame
- I Green Product (RoHS & Halogen free product)
- I On board LED Driving circuit
- I Low driving voltage and low power consumption
- I On board EDID chip

**PRODUCT GROUP**

REV

ISSUE DATE

TFT LCD PRODUCT

0

2009.6.27.

1.3 Application

I Notebook PC (Wide type)

1.4 General Specification

The followings are general specifications at the model HT140WXB-100. (listed in Table 1.)

<Table 1. General Specifications>

| Parameter | Specification | Unit | Remarks |
|---------------------|--|--------|---------|
| Active area | 309.4(H) × 173.95(V) | mm | |
| Number of pixels | 1366 (H) × 768 (V) | pixels | |
| Pixel pitch | 0.2265(H) × 0.2265 (V) | mm | |
| Pixel arrangement | RGB Vertical stripe | | |
| Display colors | 262K | colors | |
| Display mode | Normally White | | |
| Dimensional outline | 323.5 (H) × 192 (V) × 5.2 (D:max) | mm | |
| Weight | 350 (max) | g | |
| Surface treatment | Glare (Clear Black) / Hard coating 3H | | |
| Back-light | Upper edge side, 1-LED Lighting Bar type | | Note 1 |
| Power consumption | P _D : 1.1 (max) | W | |
| | P _{BL} : 3.5 (max) | W | |
| | P _{total} : 4.6 (max) | W | |

Notes : 1. LED Lighting Bar (48*LED Array)

SPEC. NUMBER
SSPEC TITLE
HT140WXB-100 Product SpecificationPAGE
5 OF 35

2.0 ABSOLUTE MAXIMUM RATINGS

The followings are maximum values which, if exceeded, may cause faulty operation or damage to the unit. The operational and non-operational maximum voltage and current values are listed in Table 2.

< Table 2. Absolute Maximum Ratings >

Ta=25+/-2°C

| Parameter | Symbol | Min. | Max. | Unit | Remarks |
|-----------------------|-----------------|----------------------|----------------------|------|---------|
| Power Supply Voltage | V _{DD} | -0.3 | 4.0 | V | Note 1 |
| Logic Supply Voltage | V _{IN} | V _{SS} -0.3 | V _{DD} +0.3 | V | |
| Operating Temperature | T _{OP} | 0 | +50 | °C | Note 2 |
| Storage Temperature | T _{ST} | -20 | +60 | °C | |

- Notes : 1. Permanent damage to the device may occur if maximum values are exceeded functional operation should be restricted to the condition described under normal operating conditions.
2. Temperature and relative humidity range are shown in the figure below.
 95 % RH Max. (40 °C ≥ Ta)
 Maximum wet - bulb temperature at 39 °C or less. (Ta > 40 °C) No condensation.

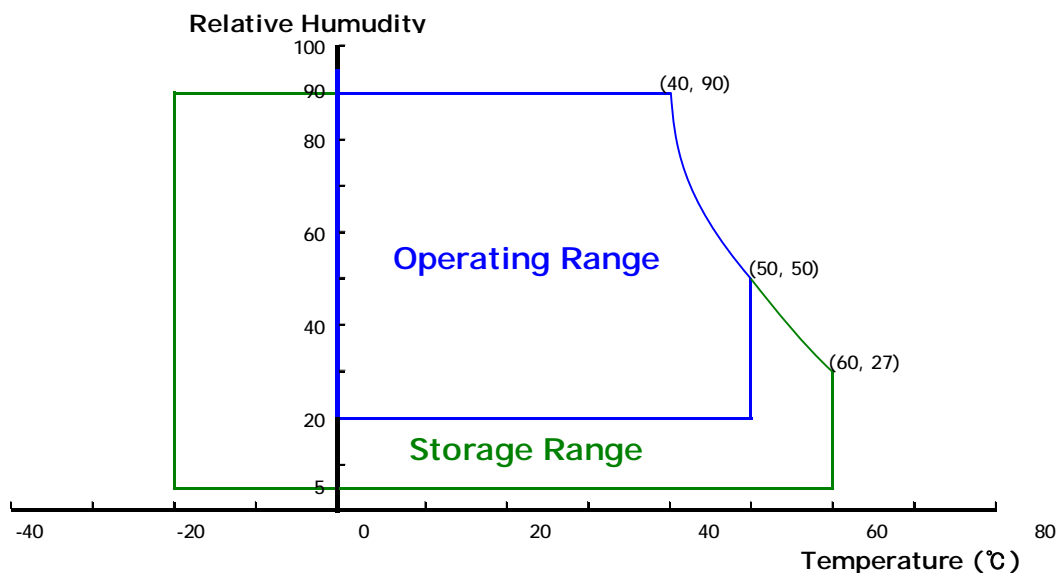

3.0 ELECTRICAL SPECIFICATIONS

3.1 Electrical Specifications

< Table 3. Electrical specifications >

Ta=25+/-2°C

| Parameter | | Min. | Typ. | Max. | Unit | Remarks |
|--|--------------------|------|------|------|------|-----------------------------|
| Power Supply Voltage | V _{DD} | 3.0 | 3.3 | 3.6 | V | Note 1 |
| Permissible Input Ripple Voltage | V _{RF} | - | - | 100 | mV | At V _{DD} = 3.3V |
| Power Supply Current | I _{DD} | - | 242 | 333 | mA | Note 1 |
| Positive-going Input Threshold Voltage | V _{IT+} | - | - | 100 | mV | V _{cm} = 1.2V typ. |
| Negative-going Input Threshold Voltage | V _{IT-} | -100 | - | - | mV | |
| Differential Input Voltage | V _{ID} | 200 | - | 600 | mV | |
| Power Consumption | P _D | - | 0.8 | 1.1 | W | Note 1 |
| | P _{BL} | - | 3.3 | 3.5 | W | Note 2 |
| | P _{total} | - | 4.1 | 4.6 | W | |

Notes : 1. The supply voltage is measured and specified at the interface connector of LCM.
The current draw and power consumption specified is for 3.3V at 25°C.

- a) Typ : Window XP pattern
- b) Max : Vertical 2 line skip pattern

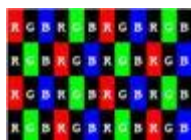

2. Calculated value for reference (V_{LED} × I_{LED})

| | | |
|-------------------|--|-----------------|
| SPEC. NUMBER S | SPEC TITLE HT140WXB-100 Product Specification | PAGE 7 OF 35 |
|-------------------|--|-----------------|

3.0 ELECTRICAL SPECIFICATIONS

3.2 Backlight Unit

< Table 4. LED Driving guideline specifications >

Ta=25+/-2°C

| Parameter | | Min. | Typ. | Max. | Unit | Remarks |
|-------------------------------------|----------------|--------|------|------|------|--------------|
| LED Forward Voltage | V_F | 3.0 | 3.2 | 3.4 | V | - |
| LED Forward Current | I_F | - | 20 | | mA | - |
| LED Power Consumption | P_{LED} | | 3.3 | 3.4 | W | Note 1 |
| LED Life-Time | N/A | 10,000 | - | - | Hour | $I_F = 20mA$ |
| Power supply voltage for LED Driver | V_{LED} | 7 | 12 | 20 | V | |
| EN Control Level | Backlight on | 2.0 | | 5.0 | V | |
| | Backlight off | 0 | | 1.0 | V | |
| PWM Control Level | PWM High Level | 2.0 | | 5.0 | V | |
| | PWM Low Level | 0 | | 0.1 | V | |
| PWM Control Frequency | F_{PWM} | 180 | 200 | 220 | Hz | |
| Duty Ratio | - | 20 | - | 100 | % | |

 Notes : 1. Calculator Value for reference $I_{LED} \times V_{LED} = P_{LED}$

2. The LED Life-time define as the estimated time to 50% degradation of initial luminous.



PRODUCT GROUP

REV

ISSUE DATE

TFT LCD PRODUCT

0

2009.6.27.

4.0 OPTICAL SPECIFICATION

4.1 Overview

The test of Optical specifications shall be measured in a dark room (ambient luminance ≤ 1 lux and temperature = $25 \pm 2^\circ\text{C}$) with the equipment of Luminance meter system (Goniometer system and TOPCON BM-5) and test unit shall be located at an approximate distance 50cm from the LCD surface at a viewing angle of Θ and Φ equal to 0° . We refer to $\Theta \emptyset = 0$ ($= \Theta 3$) as the 3 o'clock direction (the "right"), $\Theta \emptyset = 90$ ($= \Theta 12$) as the 12 o'clock direction ("upward"), $\Theta \emptyset = 180$ ($= \Theta 9$) as the 9 o'clock direction ("left") and $\Theta \emptyset = 270$ ($= \Theta 6$) as the 6 o'clock direction ("bottom"). While scanning Θ and/or \emptyset , the center of the measuring spot on the Display surface shall stay fixed. The backlight should be operating for 30 minutes prior to measurement. VDD shall be $3.3 \pm 0.3\text{V}$ at 25°C . Optimum viewing angle direction is 6 'clock.

4.2 Optical Specifications

<Table 5. Optical Specifications>

| Parameter | Symbol | Condition | Min. | Typ. | Max. | Unit | Remark | |
|----------------------------------|------------|--|---|-------|-------|-------|-------------------|--------|
| Viewing Angle range | Horizontal | Θ_3 | - | 45 | - | Deg. | Note 1 | |
| | | Θ_9 | - | 45 | - | Deg. | | |
| | Vertical | Θ_{12} | CR > 10 | - | 15 | - | | Deg. |
| | | Θ_6 | | - | 35 | - | | Deg. |
| Luminance Contrast ratio | CR | $\Theta = 0^\circ$ | 400 | 500 | | | Note 2 | |
| Luminance of White | 5 Points | Y_w | $\Theta = 0^\circ$ $I_{LED} = 20\text{mA}$ | 187 | 220 | - | cd/m ² | Note 3 |
| White Luminance uniformity | 5 Points | ΔY_5 | | 80 | - | - | | Note 4 |
| | 13 Points | ΔY_{13} | | 65 | - | - | | |
| White Chromaticity | | x_w | $\Theta = 0^\circ$ | 0.283 | 0.313 | 0.343 | | Note 5 |
| | | y_w | | 0.299 | 0.329 | 0.359 | | |
| Reproduction of color | Red | x_R | $\Theta = 0^\circ$ | 0.586 | 0.616 | 0.646 | | |
| | | y_R | | 0.325 | 0.355 | 0.385 | | |
| | Green | x_G | | 0.296 | 0.326 | 0.356 | | |
| | | y_G | | 0.584 | 0.614 | 0.644 | | |
| | Blue | x_B | | 0.116 | 0.146 | 0.176 | | |
| | | y_B | | 0.063 | 0.093 | 0.123 | | |
| Response Time (Rising + Falling) | T_{RT} | $T_a = 25^\circ\text{C}$ $\Theta = 0^\circ$ | - | 8 | 16 | ms | Note 6 | |
| Cross Talk | CT | $\Theta = 0^\circ$ | - | - | 2.0 | % | Note 7 | |

SPEC. NUMBER
S

SPEC TITLE
HT140WXB-100 Product Specification

PAGE
9 OF 35



Notes : 1. Viewing angle is the angle at which the contrast ratio is greater than 10. The viewing angles are determined for the horizontal or 3, 9 o'clock direction and the vertical or 6, 12 o'clock direction with respect to the optical axis which is normal to the LCD surface (see FIGURE 1).

2. Contrast measurements shall be made at viewing angle of $\Theta = 0$ and at the center of the LCD surface. Luminance shall be measured with all pixels in the view field set first to white, then to the dark (black) state .
(see FIGURE 1) Luminance Contrast Ratio (CR) is defined mathematically.

$$CR = \frac{\text{Luminance when displaying a white raster}}{\text{Luminance when displaying a black raster}}$$

3. Center Luminance of white is defined as luminance values of 5 point average across the LCD surface. Luminance shall be measured with all pixels in the view field set first to white. This measurement shall be taken at the locations shown in FIGURE 2 for a total of the measurements per display.

4. The White luminance uniformity on LCD surface is then expressed as : $\Delta Y = \text{Minimum Luminance of 5(or 13) points} / \text{Maximum Luminance of 5(or 13) points}$ (see FIGURE 2 and FIGURE 3).

5. The color chromaticity coordinates specified in Table 5 shall be calculated from the spectral data measured with all pixels first in red, green, blue and white. Measurements shall be made at the center of the panel.

6. The electro-optical response time measurements shall be made as FIGURE 4 by switching the "data" input signal ON and OFF. The times needed for the luminance to change from 10% to 90% is T_r , and 90% to 10% is T_d .

7. Cross-Talk of one area of the LCD surface by another shall be measured by comparing the luminance (YA) of a 25mm diameter area, with all display pixels set to a gray level, to the luminance (YB) of that same area when any adjacent area is driven dark. (See FIGURE 5).

4.3 Optical measurements

Figure 1. Measurement Set Up

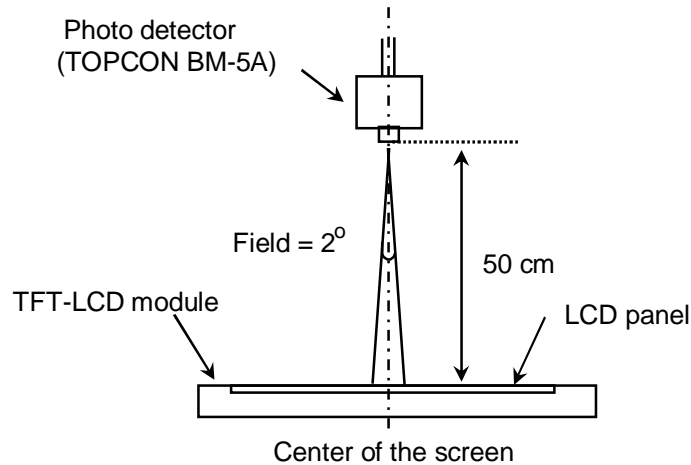

Optical characteristics measurement setup

Figure 2. White Luminance and Uniformity Measurement Locations (5 points)

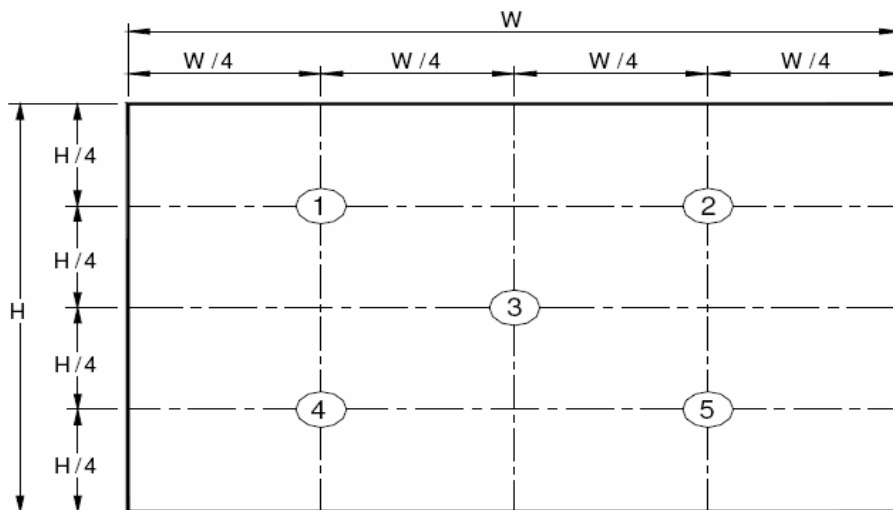

Center Luminance of white is defined as luminance values of center 5 points across the LCD surface. Luminance shall be measured with all pixels in the view field set first to white. This measurement shall be taken at the locations shown in FIGURE 2 for a total of the measurements per display.

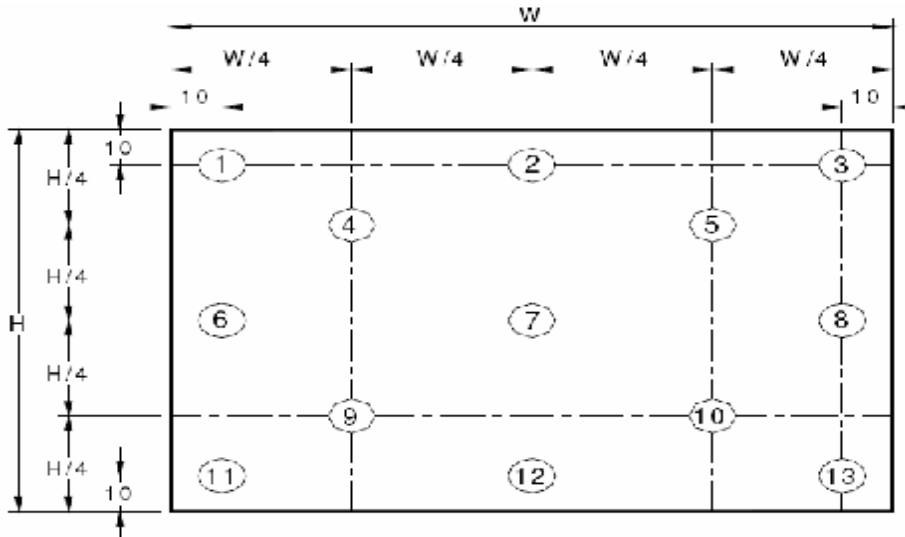
Figure 3. Uniformity Measurement Locations (13 points)

The White luminance uniformity on LCD surface is then expressed as : $\Delta Y5 = \text{Minimum Luminance of five points} / \text{Maximum Luminance of five points}$ (see FIGURE 2) , $\Delta Y13 = \text{Minimum Luminance of 13 points} / \text{Maximum Luminance of 13 points}$ (see FIGURE 3).

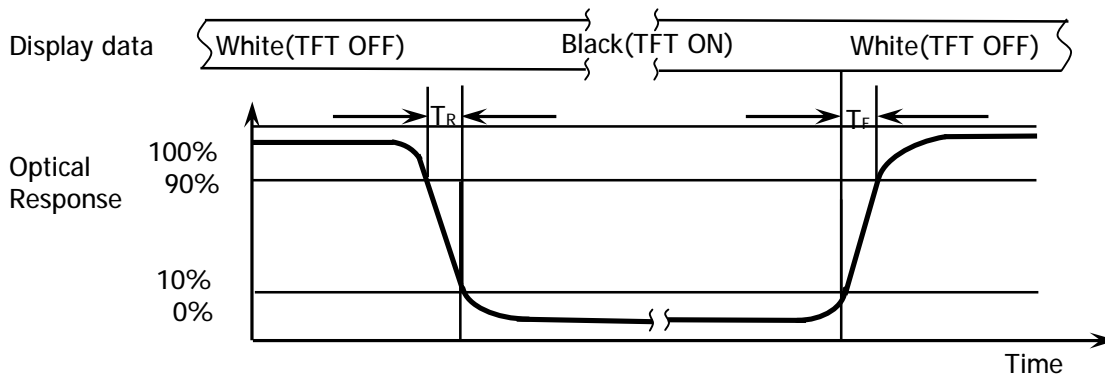
Figure 4. Response Time Testing

The electro-optical response time measurements shall be made as shown in FIGURE 4 by switching the “data” input signal ON and OFF. The times needed for the luminance to change from 10% to 90% is T_d and 90% to 10% is T_r .

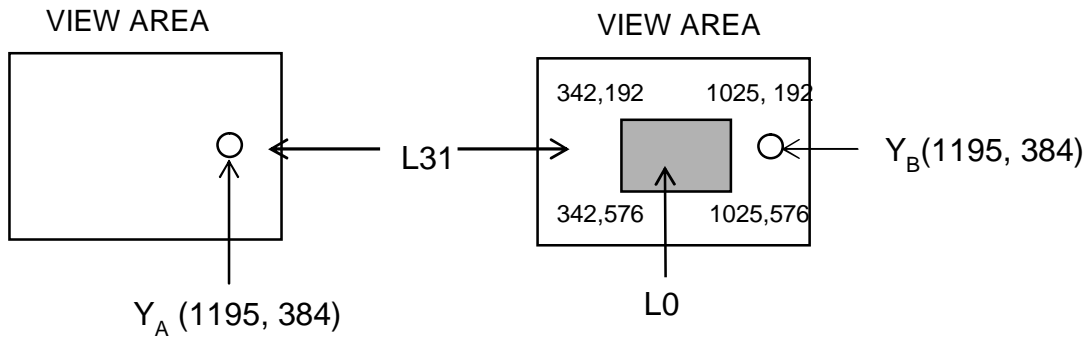
Figure 5. Cross Modulation Test Description

$$\text{Cross-Talk (\%)} = \left| \frac{Y_B - Y_A}{Y_B} \right| \times 100$$

Where:

Y_A = Initial luminance of measured area (cd/m²)

Y_B = Subsequent luminance of measured area (cd/m²)

The location measured will be exactly the same in both patterns

Cross-Talk of one area of the LCD surface by another shall be measured by comparing the luminance (Y_A) of a 25mm diameter area, with all display pixels set to a gray level, to the luminance (Y_B) of that same area when any adjacent area is driven dark (Refer to FIGURE 5).

5.0 INTERFACE CONNECTION.

5.1 Electrical Interface Connection

The electronics interface connector is I-PEX 20455-040E-12 or Compatible or equivalent. The mating connector part number is I-PEX 20455-040T-11 or Compatible. The connector interface pin assignments are listed in Table 6.

<Table 6. Pin Assignments for the Interface Connector>

| Terminal | Symbol | Functions |
|----------|-----------|-----------------------------------|
| Pin No. | Symbol | Description |
| 1 | NC | No Connection (Reserve) |
| 2 | VDDIN | Power Supply, 3.3V (typ.) |
| 3 | VDDIN | Power Supply, 3.3V (typ.) |
| 4 | VDC | VDC 3.3V power for EDID |
| 5 | NC | NC No Connection (Reserve) |
| 6 | CLK EDID | EDID Clock |
| 7 | Data EDID | EDID Data |
| 8 | RxIN0- | Transmission Data of 0 Negative - |
| 9 | RxIN0+ | Transmission Data of 0 Positive + |
| 10 | GND | Ground |
| 11 | RxIN1- | Transmission Data of 1 Negative - |
| 12 | RxIN1+ | Transmission Data of 1 Positive + |
| 13 | GND | Ground |
| 14 | RxIN2- | Transmission Data of 2 Negative - |
| 15 | RxIN2+ | Transmission Data of 2 Positive + |
| 16 | GND | Ground |
| 17 | RxCLKIN- | Sampling Clock of Negative - |
| 18 | RxCLKIN+ | Sampling Clock of Positive + |
| 19 | GND | Ground |
| 20 | NC | No Connection |
| 21 | NC | No Connection |
| 22 | GND | Ground |
| 23 | NC | No Connection |
| 24 | NC | No Connection |
| 25 | GND | Ground |
| 26 | (CE) | LCD internal use only |
| 27 | (CTL) | |
| 28 | GND | Ground |
| 29 | NC | No Connection |
| 30 | NC | No Connection |



PRODUCT GROUP

REV

ISSUE DATE

TFT LCD PRODUCT

0

2009.6.27.

| Terminal | Symbol | Functions |
|----------|----------|---------------------------|
| Pin No. | Symbol | Description |
| 31 | VLED_GND | LED Ground |
| 32 | VLED_GND | LED Ground |
| 33 | VLED_GND | LED Ground |
| 34 | NC | No Connection |
| 35 | PWM | System PWM Signal Input |
| 36 | LED_EN | LED enable pin(+3V Input) |
| 37 | NC | No Connection (Reserve) |
| 38 | VLED | LED Power Supply 7V-20V |
| 39 | VLED | LED Power Supply 7V-20V |
| 40 | VLED | LED Power Supply 7V-20V |

SPEC. NUMBER
S

SPEC TITLE
HT140WXB-100 Product Specification

PAGE
15 OF 35

5-2. LVDS Interface

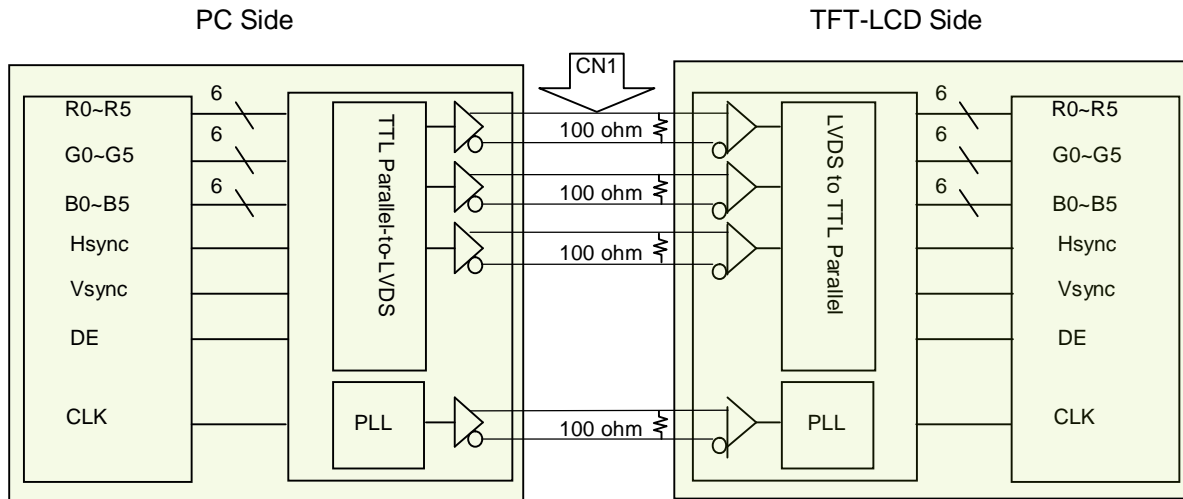

Note. Transmitter : Thine THC63LVDM63A or equivalent.
Transmitter is not contained in Module.

5.3. LVDS Input signal

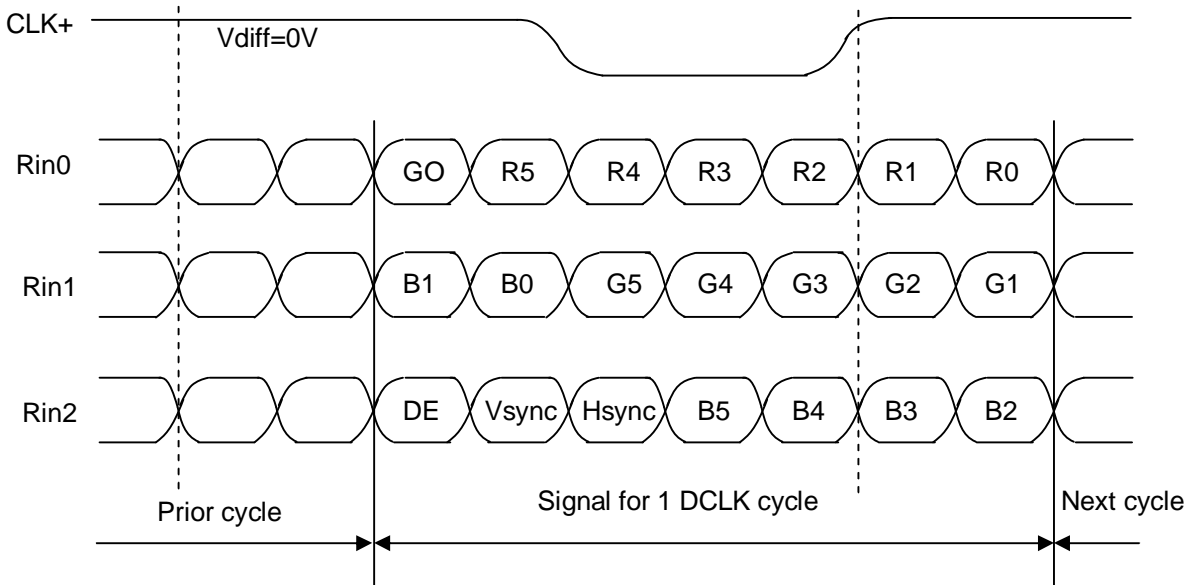

Note. Pin connection in case of using Thine THC63LVDM63A

5.3 Data Input Format

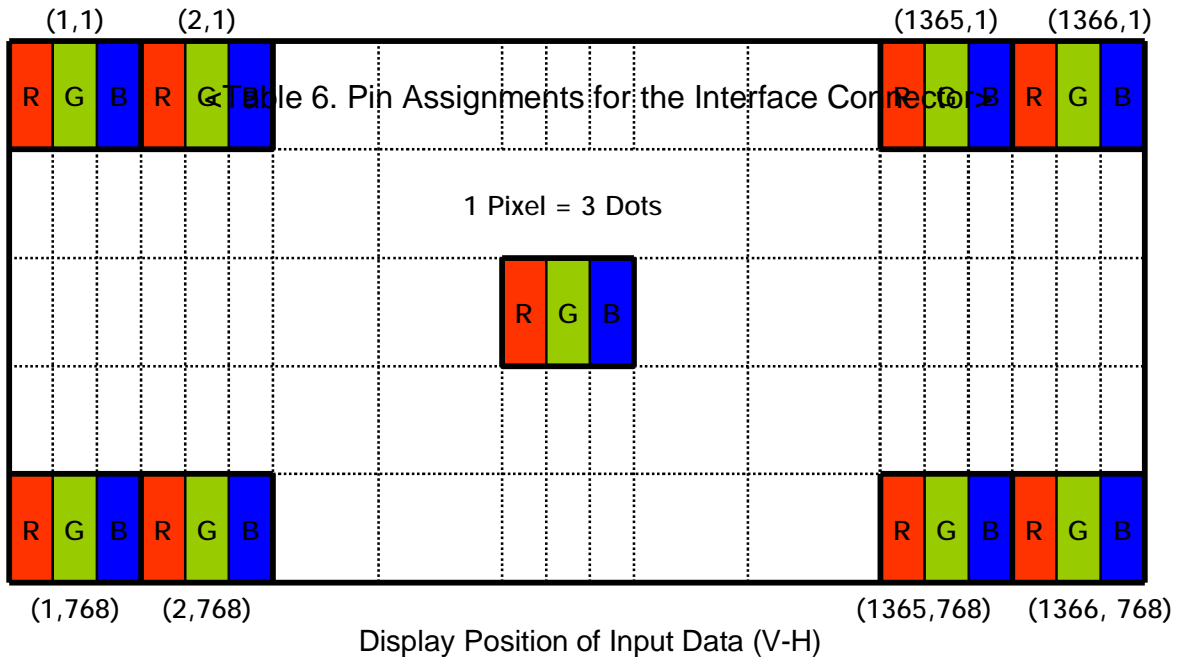

5.4 Back-light & LCM Interface Connection

Interface Connector: MS24022P10 or Equivalent

<Table 7. Pin Assignments for the BLU & LCM Connector>

| Pin No. | Symbol | Description | Pin No. | Symbol | Description |
|---------|--------|------------------------|---------|--------|------------------------|
| 1 | Vout | LED anode connection | 6 | LED2 | LED cathode connection |
| 2 | Vout | LED anode connection | 7 | LED3 | LED cathode connection |
| 3 | Vout | LED anode connection | 8 | LED4 | LED cathode connection |
| 4 | NC | No Connection | 9 | LED5 | LED cathode connection |
| 5 | LED1 | LED cathode connection | 10 | LED6 | LED cathode connection |

6.0 SIGNAL TIMING SPECIFICATION

6.1 The HT156WXB-100 is operated by the DE only.

| Item | | Symbols | Min | Typ | Max | Unit |
|---------------------------|-----------|---------|------|------|------|--------|
| Clock | Frequency | 1/Tc | 40 | 72.3 | - | MHz |
| | High Time | Tch | - | 4/7 | - | Tc |
| | Low Time | Tcl | - | 3/7 | - | Tc |
| Frame Period | | Tv | 778 | 790 | 802 | lines |
| | | | - | 60 | - | Hz |
| | | | - | 16.7 | - | ms |
| Vertical Display Period | | Tvd | 768 | 768 | 768 | lines |
| One line Scanning Period | | Th | 1446 | 1526 | 1586 | clocks |
| Horizontal Display Period | | Thd | 1366 | 1366 | 1366 | clocks |

7.0 SIGNAL TIMING WAVEFORMS OF INTERFACE SIGNAL

7.1 Sync Timing Waveforms

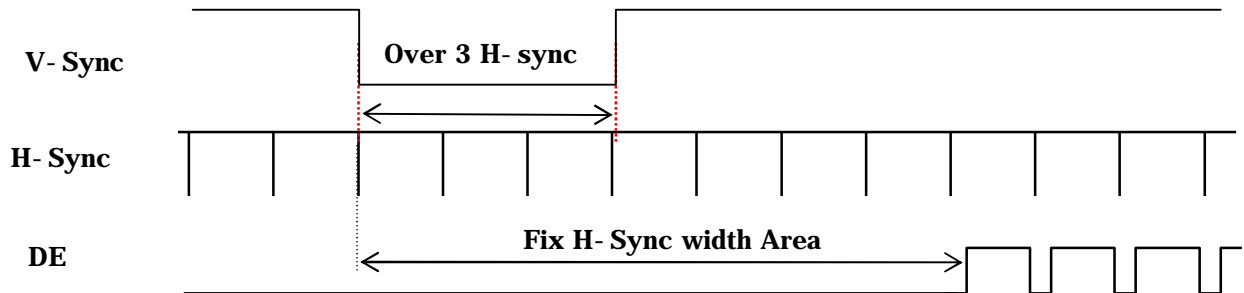

- 1) Need over 3 H-sync during V-Sync Low
- 2) Fix H-Sync width from V-Sync falling edge to first rising edge

7.2 Vertical Timing Waveforms

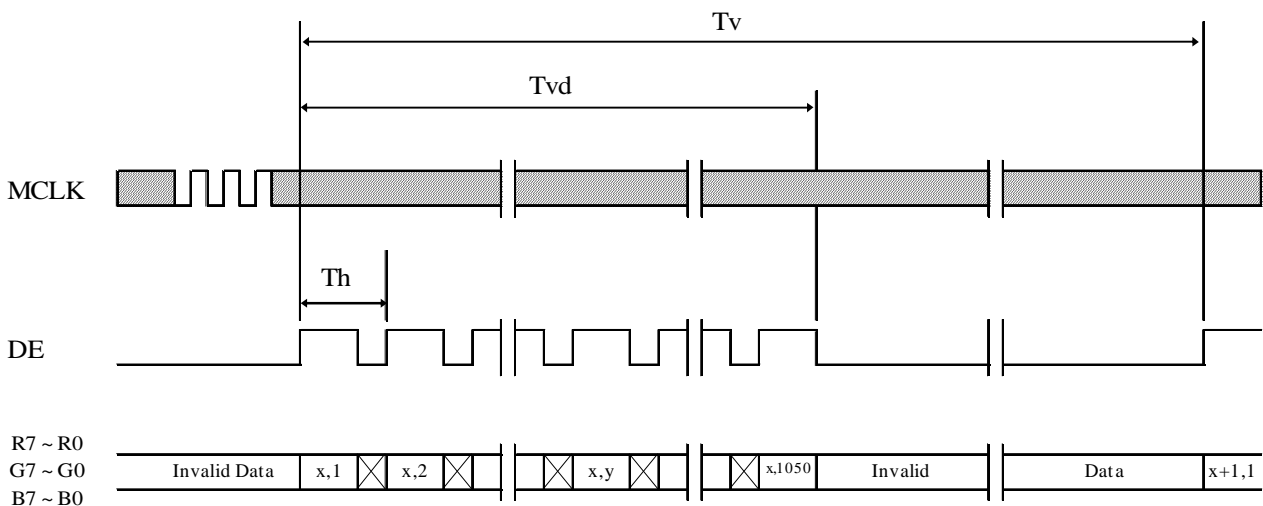

7.3 Horizontal Timing Waveforms

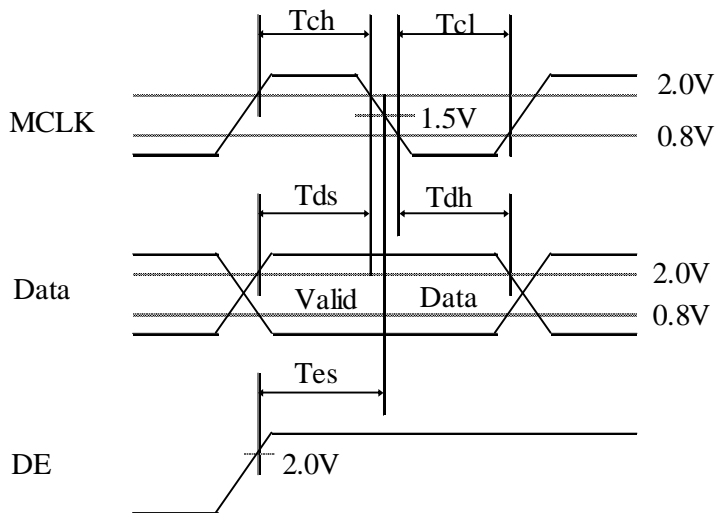
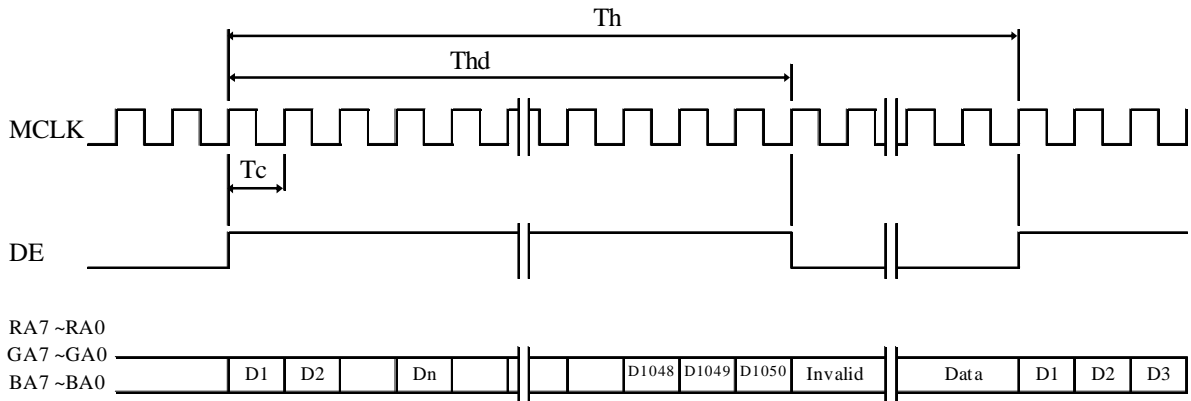

8.0 INPUT SIGNALS, BASIC DISPLAY COLORS & GRAY SCALE OF COLORS

| | Colors & Gray scale | Data signal | | | | | | | | | | | | | | | | | |
|-----------------------------|---------------------|-------------|----|----|----|----|----|----|----|----|----|----|----|----|----|----|----|----|----|
| | | R0 | R1 | R2 | R3 | R4 | R5 | G0 | G1 | G2 | G3 | G4 | G5 | B0 | B1 | B2 | B3 | B4 | B5 |
| Basic colors | Black | 0 | 0 | 0 | 0 | 0 | 0 | 0 | 0 | 0 | 0 | 0 | 0 | 0 | 0 | 0 | 0 | 0 | 0 |
| | Blue | 0 | 0 | 0 | 0 | 0 | 0 | 0 | 0 | 0 | 0 | 0 | 0 | 1 | 1 | 1 | 1 | 1 | 1 |
| | Green | 0 | 0 | 0 | 0 | 0 | 0 | 1 | 1 | 1 | 1 | 1 | 1 | 0 | 0 | 0 | 0 | 0 | 0 |
| | Light Blue | 0 | 0 | 0 | 0 | 0 | 0 | 1 | 1 | 1 | 1 | 1 | 1 | 1 | 1 | 1 | 1 | 1 | 1 |
| | Red | 1 | 1 | 1 | 1 | 1 | 1 | 0 | 0 | 0 | 0 | 0 | 0 | 0 | 0 | 0 | 0 | 0 | 0 |
| | Purple | 1 | 1 | 1 | 1 | 1 | 1 | 0 | 0 | 0 | 0 | 0 | 0 | 1 | 1 | 1 | 1 | 1 | 1 |
| | Yellow | 1 | 1 | 1 | 1 | 1 | 1 | 1 | 1 | 1 | 1 | 1 | 1 | 0 | 0 | 0 | 0 | 0 | 0 |
| | White | 1 | 1 | 1 | 1 | 1 | 1 | 1 | 1 | 1 | 1 | 1 | 1 | 1 | 1 | 1 | 1 | 1 | 1 |
| Gray scale of Red | Black | 0 | 0 | 0 | 0 | 0 | 0 | 0 | 0 | 0 | 0 | 0 | 0 | 0 | 0 | 0 | 0 | 0 | 0 |
| | △ | 1 | 0 | 0 | 0 | 0 | 0 | 0 | 0 | 0 | 0 | 0 | 0 | 0 | 0 | 0 | 0 | 0 | 0 |
| | Darker | 0 | 1 | 0 | 0 | 0 | 0 | 0 | 0 | 0 | 0 | 0 | 0 | 0 | 0 | 0 | 0 | 0 | 0 |
| | △ | | | | | | | | | | | | | | | | | | |
| | ▽ | | | | | | | | | | | | | | | | | | |
| | Brighter | 1 | 0 | 1 | 1 | 1 | 1 | 0 | 0 | 0 | 0 | 0 | 0 | 0 | 0 | 0 | 0 | 0 | 0 |
| Gray scale of Green | Black | 0 | 0 | 0 | 0 | 0 | 0 | 0 | 0 | 0 | 0 | 0 | 0 | 0 | 0 | 0 | 0 | 0 | 0 |
| | △ | 0 | 0 | 0 | 0 | 0 | 0 | 1 | 0 | 0 | 0 | 0 | 0 | 0 | 0 | 0 | 0 | 0 | 0 |
| | Darker | 0 | 0 | 0 | 0 | 0 | 0 | 0 | 1 | 0 | 0 | 0 | 0 | 0 | 0 | 0 | 0 | 0 | 0 |
| | △ | | | | | | | | | | | | | | | | | | |
| | ▽ | | | | | | | | | | | | | | | | | | |
| | Brighter | 0 | 0 | 0 | 0 | 0 | 0 | 1 | 0 | 1 | 1 | 1 | 1 | 0 | 0 | 0 | 0 | 0 | 0 |
| Gray scale of Blue | Black | 0 | 0 | 0 | 0 | 0 | 0 | 0 | 0 | 0 | 0 | 0 | 0 | 0 | 0 | 0 | 0 | 0 | 0 |
| | △ | 0 | 0 | 0 | 0 | 0 | 0 | 0 | 0 | 0 | 0 | 0 | 0 | 1 | 0 | 0 | 0 | 0 | 0 |
| | Darker | 0 | 0 | 0 | 0 | 0 | 0 | 0 | 0 | 0 | 0 | 0 | 0 | 0 | 1 | 0 | 0 | 0 | 0 |
| | △ | | | | | | | | | | | | | | | | | | |
| | ▽ | | | | | | | | | | | | | | | | | | |
| | Brighter | 0 | 0 | 0 | 0 | 0 | 0 | 0 | 0 | 0 | 0 | 0 | 0 | 1 | 0 | 1 | 1 | 1 | 1 |
| Gray scale of White & Black | Black | 0 | 0 | 0 | 0 | 0 | 0 | 0 | 0 | 0 | 0 | 0 | 0 | 0 | 0 | 0 | 0 | 0 | 0 |
| | △ | 1 | 0 | 0 | 0 | 0 | 0 | 1 | 0 | 0 | 0 | 0 | 0 | 1 | 0 | 0 | 0 | 0 | 0 |
| | Darker | 0 | 1 | 0 | 0 | 0 | 0 | 0 | 1 | 0 | 0 | 0 | 0 | 0 | 1 | 0 | 0 | 0 | 0 |
| | △ | | | | | | | | | | | | | | | | | | |
| | ▽ | | | | | | | | | | | | | | | | | | |
| | Brighter | 1 | 0 | 1 | 1 | 1 | 1 | 1 | 0 | 1 | 1 | 1 | 1 | 1 | 0 | 1 | 1 | 1 | 1 |
| White | 1 | 1 | 1 | 1 | 1 | 1 | 1 | 1 | 1 | 1 | 1 | 1 | 1 | 1 | 1 | 1 | 1 | 1 | |

9.0 POWER SEQUENCE

To prevent a latch-up or DC operation of the LCD module, the power on/off sequence shall be as shown in below

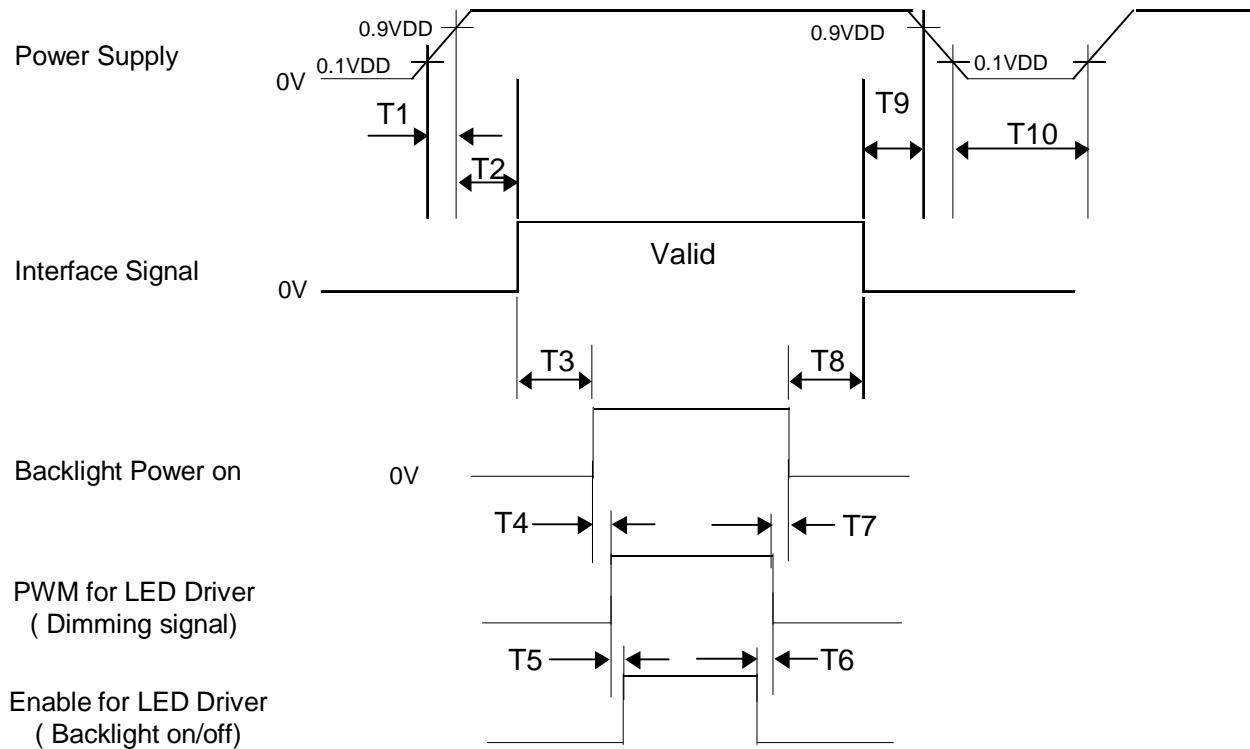

- $T1 \leq 10 \text{ ms}$
- $0 \text{ ms} \leq T2 \leq 50 \text{ ms}$
- $200 \text{ ms} \leq T3$
- $10 \text{ ms} \leq T4$
- $10 \text{ ms} \leq T5$
- $0 \text{ ms} \leq T6$
- $10 \text{ ms} \leq T7$
- $200 \text{ ms} \leq T8$
- $0 \text{ ms} \leq T9 \leq 50 \text{ ms}$
- $1 \text{ s} \leq T10$

Notes:

1. When the power supply VDD is 0V, keep the level of input signals on the low or keep high impedance.
2. Do not keep the interface signal high impedance when power is on. Back Light must be turn on after power for logic and interface signal are valid.



10.0 Connector Description

Physical interface is described as for the connector on LCM.

These connectors are capable of accommodating the following signals and will be following components.

10.1 TFT LCD Module

| Connector Name /Description | For Signal Connector |
|-----------------------------|-----------------------------------|
| Manufacturer | IPEX or Compatible |
| Type/ Part Number | I-PEX 20455-040E-12 or Compatible |
| Mating housing/ Part Number | I-PEX 20455-040T-11 or Compatible |



PRODUCT GROUP

REV

ISSUE DATE

TFT LCD PRODUCT

0

2009.6.27.

11.0 MECHANICAL CHARACTERISTICS

11.1 Dimensional Requirements

FIGURE 6 shows mechanical outlines for the model HT140WXB-100. Other parameters are shown in Table 9.

<Table 9. Dimensional Parameters>

| Parameter | Specification | Unit |
|---------------------|---|------|
| Active Area | 309.40 (H) × 173.95 (V) | |
| Number of pixels | 1366 (H) X 768 (V) (1 pixel = R + G + B dots) | |
| Pixel pitch | 0.2265 (H) X 0.2265 (V) | |
| Pixel arrangement | RGB Vertical stripe | |
| Display colors | 262K | |
| Display mode | Normally white | |
| Dimensional outline | 323.5*192*5.2 (max) | mm |
| Weight | 350 (max) | gram |
| Back Light | Connector : MS24022P10 | |
| | LED, Horizontal-LED Array type | |

10.2 Mounting

See FIGURE 6.

10.3 Glare and Polarizer Hardness.

The surface of the LCD has an glare coating to maximize readability and hard coating to reduce scratching.

10.4 Light Leakage

There shall not be visible light from the back-lighting system around the edges of the screen as seen from a distance 50cm from the screen with an overhead light level of 350lux.

SPEC. NUMBER
S

SPEC TITLE
HT140WXB-100 Product Specification

PAGE
25 OF 35

12.0 RELIABILITY TEST

The Reliability test items and its conditions are shown in below.

<Table 10. Reliability test>

| No | Test Items | Conditions |
|----|--|--|
| 1 | High temperature storage test | Ta = 60 °C, 240 hrs |
| 2 | Low temperature storage test | Ta = -20 °C, 240 hrs |
| 3 | High temperature & high humidity operation test | Ta = 50 °C, 80%RH, 240 hrs |
| 4 | High temperature operation test | Ta = 50 °C, 240 hrs |
| 5 | Low temperature operation test | Ta = 0 °C, 240 hrs |
| 6 | Thermal shock | Ta = -20 °C ↔ 60 °C (0.5 hr), 100 cycle |
| 7 | Vibration test (non-operating) | 1.5G, 10~500Hz Sine X,Y,Z / Sweep rate : 0.5hour |
| 8 | Shock test (non-operating) | 220G, Half Sine Wave 2msec ±X, ±Y, ±Z Once for each direction |
| 9 | Electro-static discharge test (non-operating) | Air : 150 pF, 330Ω, 15 KV Contact : 150 pF, 330Ω, 8 KV |

13.0 HANDLING & CAUTIONS

(1) Cautions when taking out the module

ÿ Pick the pouch only, when taking out module from a shipping package.

(2) Cautions for handling the module

ÿ As the electrostatic discharges may break the LCD module, handle the LCD module with care. Peel a protection sheet off from the LCD panel surface as slowly as possible.

ÿ As the LCD panel and back - light element are made from fragile glass material, impulse and pressure to the LCD module should be avoided.

ÿ As the surface of the polarizer is very soft and easily scratched, use a soft dry cloth without chemicals for cleaning.

ÿ Do not pull the interface connector in or out while the LCD module is operating.

ÿ Put the module display side down on a flat horizontal plane.

ÿ Handle connectors and cables with care.

(3) Cautions for the operation

ÿ When the module is operating, do not lose CLK, ENAB signals. If any one of these signals is lost, the LCD panel would be damaged.

ÿ Obey the supply voltage sequence. If wrong sequence is applied, the module would be damaged.



PRODUCT GROUP

REV

ISSUE DATE

TFT LCD PRODUCT

0

2009.6.27.

(4) Cautions for the atmosphere

ÿ Dew drop atmosphere should be avoided.

ÿ Do not store and/or operate the LCD module in a high temperature and/or humidity atmosphere. Storage in an electro-conductive polymer packing pouch and under relatively low temperature atmosphere is recommended.

(5) Cautions for the module characteristics

ÿ Do not apply fixed pattern data signal to the LCD module at product aging.

ÿ Applying fixed pattern for a long time may cause image sticking.

(6) Other cautions

ÿ Do not disassemble and/or re-assemble LCD module.

ÿ Do not re-adjust variable resistor or switch etc.

ÿ When returning the module for repair or etc., Please pack the module not to be broken. We recommend to use the original shipping packages.

14.0 LABEL

(1) Product label



1 2 3 4 5 6 7

| | | | | | | | | | | | | | | | | |
|---|---|---|---|---|---|---|---|---|---|---|---|---|---|---|---|---|
| X | X | X | X | X | X | 1 | 0 | 0 | X | X | X | X | X | X | X | X |
|---|---|---|---|---|---|---|---|---|---|---|---|---|---|---|---|---|

Type designation

No 1. Control Number

No 2. Rank / Grade

No 3. Line classification (BOE OT:A/BC)

No 4. Year (05 : 2005, 06: 2006, ...)

No 5. Month (1, 2, 3, ..., 9, X, Y, Z)

No 6. Product Identification (FG)

No 7. Serial Number

| | | |
|-------------------|--|------------------|
| SPEC. NUMBER S | SPEC TITLE HT140WXB-100 Product Specification | PAGE 27 OF 35 |
|-------------------|--|------------------|



PRODUCT GROUP

REV

ISSUE DATE

TFT LCD PRODUCT

0

2009.6.27.

(2) High voltage caution label

| | | |
|--|---|---|
| | <p>HIGH VOLTAGE CAUTION</p> | <p>COLD CATHODE FLUORESCENT LAMP IN LCD PANEL CONTAINS A SMALL AMOUNT OF MERCURY. PLEASE FOLLOW LOCAL OR- DINANCES OR REGULATIONS FOR DISPOSAL.</p> |
| | <p>RISK OF ELECTRIC SHOCK, DISCONNECT THE ELECTRIC POWER BEFORE SERVICING</p> | |

(3) Box label

Label Size: 110 mm (L) × 56 mm (W)

Contents

Model: HT140WXB-100

Q`ty: Module Q`ty in one box

Serial No.: Box Serial No. See next figure for detail description.

Date: Packing Date

Internal use of Product



| | | | | | | |
|-----------|----------|----------|-----------|----------|--------------|---------------|
| <u>00</u> | <u>0</u> | <u>0</u> | <u>00</u> | <u>0</u> | <u>0000</u> | <u>000000</u> |
| Type | Grade | Line | Year | Month | Internal use | Serial No |

SPEC. NUMBER

S

SPEC TITLE

HT140WXB-100 Product Specification

PAGE

28 OF 35

15.0 PACKING INFORMATION

15.1 Packing order

Put Pad into the box.



As shown in the figure, place the paper spacer and modules bundled by PE bag in the box.

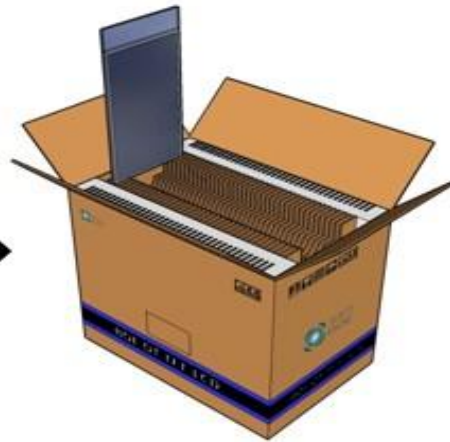

After sealing the box, attach Packing Label on the attach position sign area of the box.

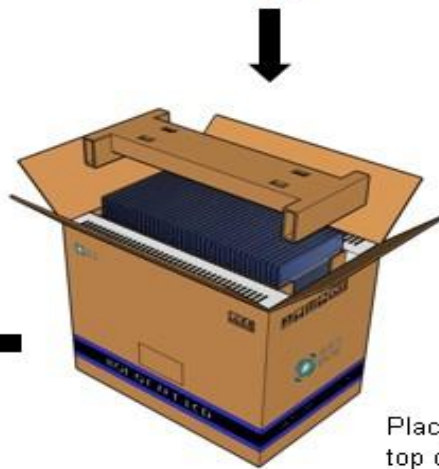

Place Cover Pad on the top of the box.

15.2 Notes

- I Box Dimension: 526mm(W) x 346mm(D) x 448mm(H)
- I Package Quantity in one Box: 38pcs
- I Total Weight: 16kg

16.0 MECHANICAL OUTLINE DIMENSION

Figure 6. TFT-LCD Module Outline Dimension (Front View)

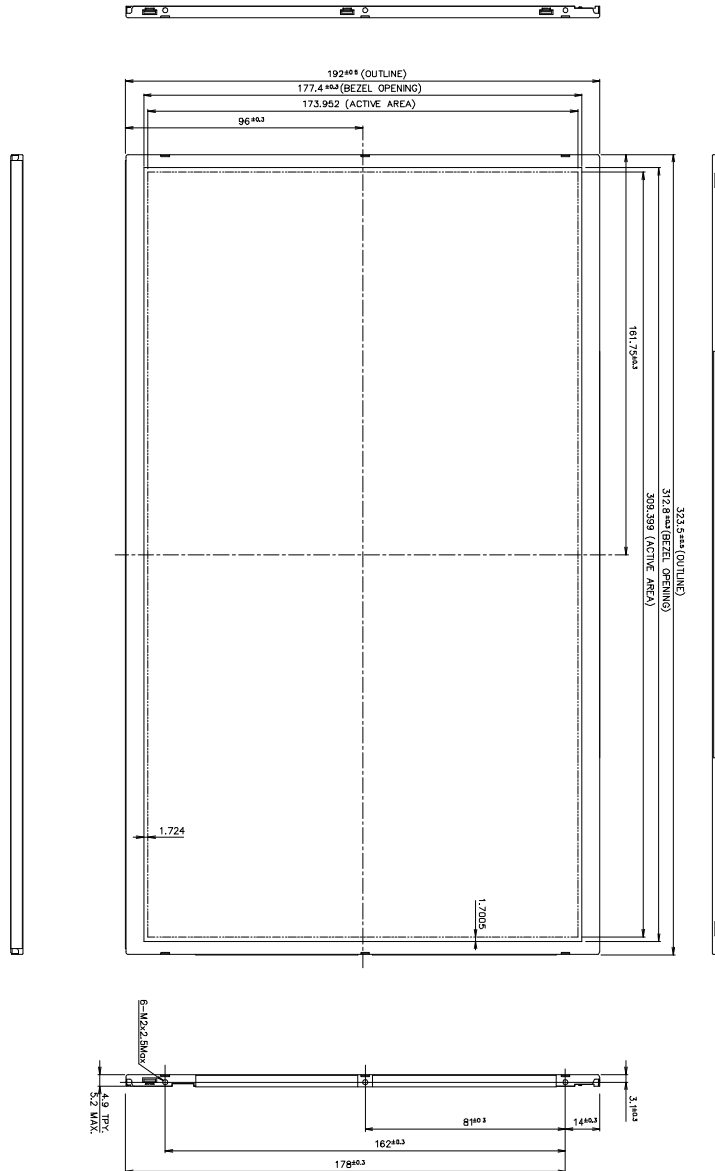

SPEC. NUMBER
S

SPEC TITLE
HT140WXB-100 Product Specification

PAGE
30 OF 35

Figure 7. TFT-LCD Module Outline Dimensions (Rear view)

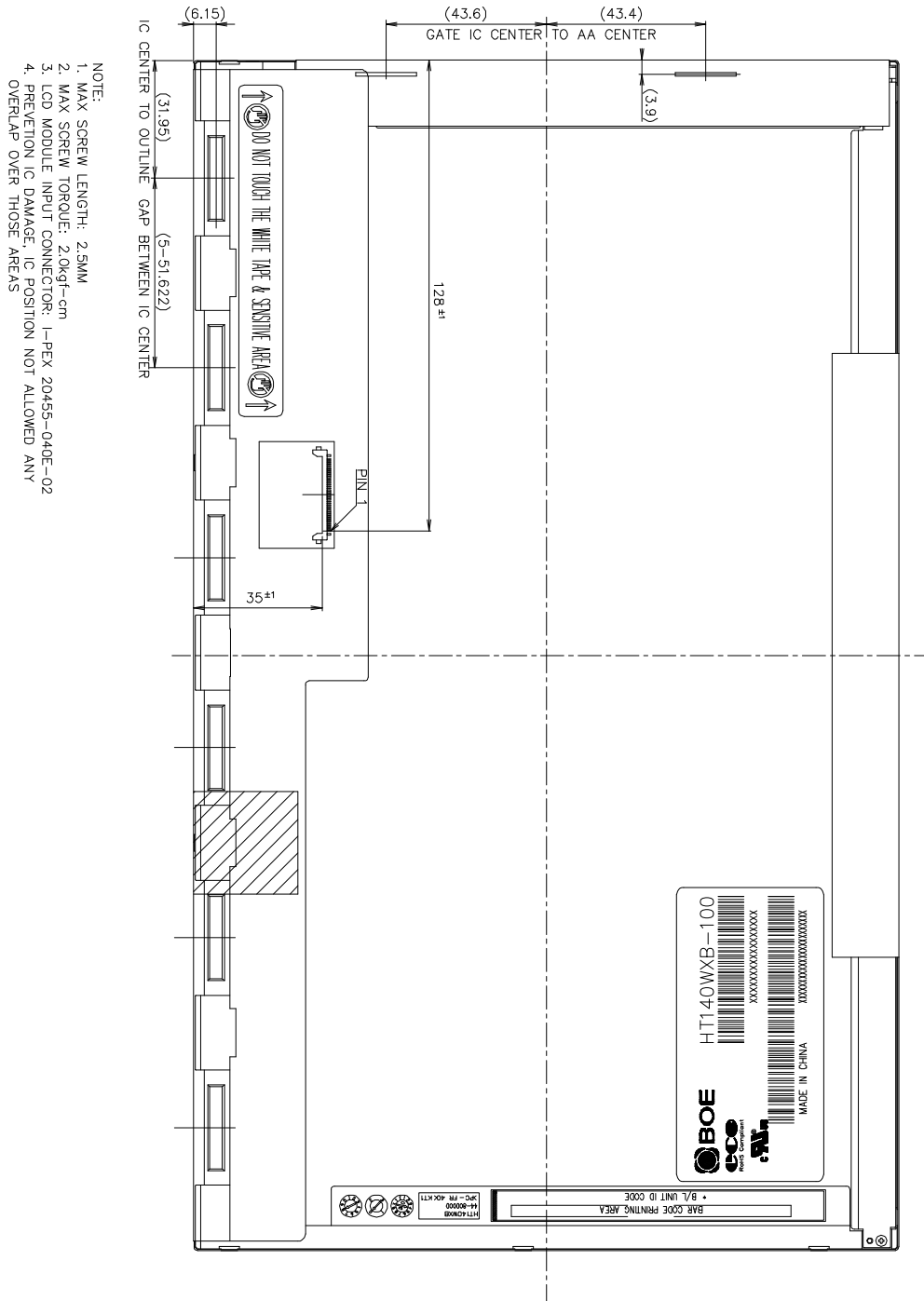



PRODUCT GROUP

REV

ISSUE DATE

TFT LCD PRODUCT

0

2009.6.27.

17.0 EDID Table

| Address (HEX) | Function | Hex | Dec | values. | Notes |
|---------------|------------------------|-----|-----|---------|-------------------------------------|
| 00 | Header | 00 | 0 | 0 | EDID Header |
| 01 | | FF | 255 | 255 | |
| 02 | | FF | 255 | 255 | |
| 03 | | FF | 255 | 255 | |
| 04 | | FF | 255 | 255 | |
| 05 | | FF | 255 | 255 | |
| 06 | | FF | 255 | 255 | |
| 07 | | 00 | 0 | 0 | |
| 08 | ID Manufacturer Name | 09 | 9 | BOE | ID = BOE |
| 09 | | E5 | 229 | | |
| 0A | ID Product Code | 86 | 134 | 1414 | ID = 1414 WXGA |
| 0B | | 05 | 5 | | |
| 0C | 32-bit serial No. | 00 | 0 | | |
| 0D | | 00 | 0 | | |
| 0E | | 00 | 0 | | |
| 0F | | 00 | 0 | | |
| 10 | Week of manufacture | 01 | 1 | 1 | |
| 11 | Year of Manufacture | 13 | 19 | 2009 | Manufactured in 2009 |
| 12 | EDID Structure Ver. | 01 | 1 | 1 | EDID Ver 1.0 |
| 13 | EDID revision # | 03 | 3 | 3 | EDID Rev. 0.3 |
| 14 | Video input definition | 80 | 128 | - | |
| 15 | Max H image size | 1F | 31 | 31 | 31 cm (Approx) |
| 16 | Max V image size | 11 | 17 | 17 | 17 cm (Approx) |
| 17 | Display Gamma | 78 | 120 | 2.2 | Gamma curve = 2.2 |
| 18 | Feature support | 0A | 10 | | RGB display, Preferred Timming mode |
| 19 | Red/Green low bits | 22 | 34 | - | Red / Green Low Bits |
| 1A | Blue/White low bits | C0 | 192 | - | Blue / White Low Bits |
| 1B | Red x high bits | 95 | 149 | 0.583 | Red (x) = 10010101 (0.58348) |
| 1C | Red y high bits | 56 | 86 | 0.338 | Red (y) = 01010110 (0.33836) |
| 1D | Green x high bits | 4E | 78 | 0.305 | Green (x) = 01001110 (0.30482) |
| 1E | Green y high bits | 8E | 142 | 0.557 | Green (y) = 10001110 (0.55656) |
| 1F | Blue x high bits | 26 | 38 | 0.148 | Blue (x) = 00100110 (0.14812) |
| 20 | BLue y high bits | 24 | 36 | 0.141 | Blue (y) = 00100100 (0.14068) |
| 21 | White x high bits | 50 | 80 | 0.313 | White (x) = 01010000 (0.313) |
| 22 | White y high bits | 54 | 84 | 0.329 | White (y) = 01010100 (0.329) |

SPEC. NUMBER
S

SPEC TITLE
HT140WXB-100 Product Specification

PAGE
32 OF 35



PRODUCT GROUP

REV

ISSUE DATE

TFT LCD PRODUCT

0

2009.6.27.

| Address (HEX) | Function | Hex | Dec | values. | Notes |
|---------------|---|-----|-----|---------|---|
| 23 | Established timing 1 | 00 | 0 | - | |
| 24 | Established timing 2 | 00 | 0 | - | |
| 25 | Established timing 3 | 00 | 0 | - | |
| 26 | Standard timing #1 | 01 | 1 | | Not Used |
| 27 | | 01 | 1 | | |
| 28 | Standard timing #2 | 01 | 1 | | Not Used |
| 29 | | 01 | 1 | | |
| 2A | Standard timing #3 | 01 | 1 | | Not Used |
| 2B | | 01 | 1 | | |
| 2C | Standard timing #4 | 01 | 1 | | Not Used |
| 2D | | 01 | 1 | | |
| 2E | Standard timing #5 | 01 | 1 | | Not Used |
| 2F | | 01 | 1 | | |
| 30 | Standard timing #6 | 01 | 1 | | Not Used |
| 31 | | 01 | 1 | | |
| 32 | Standard timing #7 | 01 | 1 | | Not Used |
| 33 | | 01 | 1 | | |
| 34 | Standard timing #8 | 01 | 1 | | Not Used |
| 35 | | 01 | 1 | | |
| 36 | Detailed timing/monitor descriptor #1 (60Hz) | 41 | 65 | 72.33 | 72.33MHz Main clock |
| 37 | | 1C | 28 | | |
| 38 | | 56 | 86 | 1366 | Hor Active = 1366 |
| 39 | | A0 | 160 | 160 | Hor Blanking = 160 |
| 3A | | 50 | 80 | - | 4 bits of Hor. Active + 4 bits of Hor. Blanking |
| 3B | | 00 | 0 | 768 | Ver Active = 768 |
| 3C | | 16 | 22 | 22 | Ver Blanking = 22 |
| 3D | | 30 | 48 | - | 4 bits of Ver. Active + 4 bits of Ver. Blanking |
| 3E | | 30 | 48 | 48 | Hor Sync Offset = 48 |
| 3F | | 20 | 32 | 32 | H Sync Pulse Width = 32 |
| 40 | | 36 | 54 | 3 | V sync Offset = 3 line |
| 41 | | 00 | 0 | 6 | V Sync Pulse width : 6 line |
| 42 | | 35 | 53 | 309 | Horizontal Image Size = 309 mm (Low 8 bits) |
| 43 | | AD | 173 | 173 | Vertical Image Size = 173 mm (Low 8 bits) |
| 44 | | 10 | 16 | - | 4 bits of Hor Image Size + 4 bits of Ver Image Size |
| 45 | | 00 | 0 | 0 | Hor Border (pixels) |
| 46 | | 00 | 0 | 0 | Vertical Border (Lines) |
| 47 | 19 | 25 | - | | |

SPEC. NUMBER
S

SPEC TITLE
HT140WXB-100 Product Specification

PAGE
33 OF 35



PRODUCT GROUP

REV

ISSUE DATE

TFT LCD PRODUCT

0

2009.6.27.

| Address (HEX) | Function | Hex | Dec | values. | Notes | |
|---------------|---------------------------------------|-----|-----|---------|----------------------------|--|
| 48 | Detailed timing/monitor descriptor #2 | 00 | 0 | | | |
| 49 | | 00 | 0 | | | |
| 4A | | 00 | 0 | | | |
| 4B | | FE | 0 | | | |
| 4C | | 00 | 0 | | | |
| 4D | | 0A | 0 | | | |
| 4E | | 20 | 0 | | | |
| 4F | | 20 | 0 | | | |
| 50 | | 20 | 0 | | | |
| 51 | | 20 | 0 | | | |
| 52 | | 20 | 0 | | | |
| 53 | | 20 | 0 | | | |
| 54 | | 20 | 0 | | | |
| 55 | | 20 | 0 | | | |
| 56 | | 20 | 0 | | | |
| 57 | | 20 | 0 | | | |
| 58 | 20 | 0 | | | | |
| 59 | 20 | 0 | | | | |
| 5A | Detailed timing/monitor descriptor #3 | 00 | 0 | | ASCII Data String Tag | |
| 5B | | 00 | 0 | | | |
| 5C | | 00 | 0 | | | |
| 5D | | FE | 254 | | | |
| 5E | | 00 | 0 | | | |
| 5F | | 42 | 66 | B | Manufacturer name : BOE OT | |
| 60 | | 4F | 79 | O | | |
| 61 | | 45 | 69 | E | | |
| 62 | | 20 | 32 | | | |
| 63 | | 4F | 79 | O | | |
| 64 | | 54 | 84 | T | | |
| 65 | | 0A | 10 | | | |
| 66 | | 20 | 32 | | | |
| 67 | | 20 | 32 | | | |
| 68 | 20 | 32 | | | | |
| 69 | 20 | 32 | | | | |
| 6A | 20 | 32 | | | | |
| 6B | 20 | 32 | | | | |

SPEC. NUMBER
S

SPEC TITLE
HT140WXB-100 Product Specification

PAGE
34 OF 35



PRODUCT GROUP

REV

ISSUE DATE

TFT LCD PRODUCT

0

2009.6.27.

| Address (HEX) | Function | Hex | Dec | values. | Notes |
|---------------|---------------------------------------|-----|-----|---------|---------------------------|
| 6C | Detailed timing/monitor descriptor #4 | 00 | 0 | | Product Name Tag (ASCII) |
| 6D | | 00 | 0 | | |
| 6E | | 00 | 0 | | |
| 6F | | FE | 254 | | |
| 70 | | 00 | 0 | | |
| 71 | | 48 | 72 | H | Model name : HT140WXB-100 |
| 72 | | 54 | 84 | T | |
| 73 | | 31 | 49 | 1 | |
| 74 | | 34 | 52 | 4 | |
| 75 | | 30 | 48 | 0 | |
| 76 | | 57 | 87 | W | |
| 77 | | 58 | 88 | X | |
| 78 | | 42 | 66 | B | |
| 79 | | 2D | 45 | - | |
| 7A | | 31 | 49 | 1 | |
| 7B | | 30 | 48 | 0 | |
| 7C | 30 | 48 | 0 | | |
| 7D | 0A | 10 | | | |
| 7E | Extension flag | 00 | 0 | | |
| 7F | Checksum | 51 | 81 | - | |

SPEC. NUMBER
S

SPEC TITLE
HT140WXB-100 Product Specification

PAGE
35 OF 35