



**PROPRIETARY NOTE**

THIS SPECIFICATION IS THE PROPERTY OF BOE OT AND SHALL NOT BE REPRODUCED OR COPIED WITHOUT THE WRITTEN PERMISSION OF BOE OT AND MUST BE RETURNED TO BOE OT UPON ITS REQUEST

**HT140WXB-101**  
**Product Specification**  
**Rev. 0**

**BEIJING BOE OPTOELECTRONICS TECHNOLOGY**

SPEC. NUMBER S	PRODUCT GROUP TFT-LCD	REV. 0	ISSUE DATE 2010.2.11	PAGE 1 OF 35
-------------------	--------------------------	-----------	-------------------------	-----------------



**PRODUCT GROUP**

REV

ISSUE DATE

TFT LCD PRODUCT

0

2010.2.11

**Contents**

No.	Items	Page
1.0	General Description	4
2.0	Absolute Maximum ratings	6
3.0	Electrical specifications.	7
4.0	Optical specifications.	9
5.0	Interface Connection	14
6.0	Signal Timing Specification	18
7.0	Signal Timing waveforms	20
8.0	Input Signals, Display Colors & Gray Scale of Colors	22
9.0	Power Sequence	23
10.0	Connector description	24
11.0	Mechanical Characteristics	25
12.0	Reliability Test	26
13.0	Handling & Cautions.	26
14.0	Label	27
15.0	Packing information	29
16.0	Mechanical Outline Dimension	30
17.0	EDID Table	32

SPEC. NUMBER  
SSPEC TITLE  
HT140WXB-101 Product SpecificationPAGE  
3 OF 35

## 1.0 GENERAL DESCRIPTION

### 1.1 Introduction

HT140WXB-101 is a color active matrix TFT LCD module using amorphous silicon TFT's (Thin Film Transistors) as an active switching devices. This module has a 14.0 inch diagonally measured active area with WXGA resolutions (1366 horizontal by 768 vertical pixel array). Each pixel is divided into RED, GREEN, BLUE dots which are arranged in vertical Stripe and this module can display 262,144 colors. The TFT-LCD panel used for this module is a low reflection and higher color type. Therefore, this module is suitable for Notebook PC. The LED Driver for back-light driving is built in this model. All input signals are LVDS interface compatible.

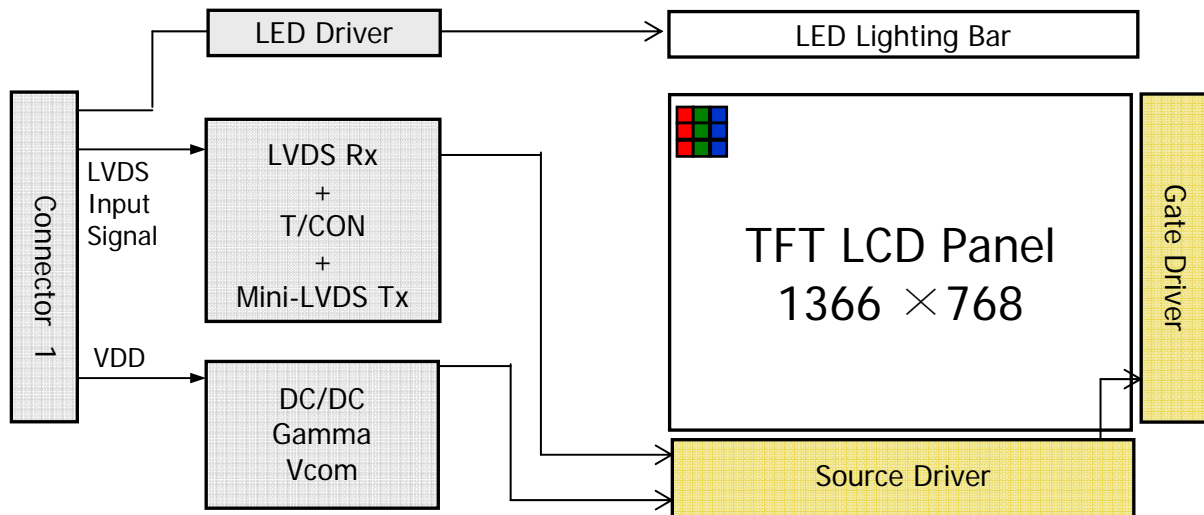

### 1.2 Features

- 1 Channel LVDS Interface with 1 pixel / clock
- Thin and light weight
- 6-bit color depth, display 262K colors
- Single LED Lighting Bar. (Top side/Horizontal Direction)
- Data enable signal mode
- Side Mounting Frame
- Green Product (RoHS & Halogen free product)
- On board LED Driving circuit
- Low driving voltage and low power consumption
- On board EDID chip



# PRODUCT GROUP

REV

ISSUE DATE

TFT LCD PRODUCT

0

2010.2.11

## 1.3 Application

- Notebook PC (Wide type)

## 1.4 General Specification

The followings are general specifications at the model HT140WXB-101. (listed in Table 1.)

<Table 1. General Specifications>

Parameter	Specification	Unit	Remarks
Active area	309.4(H) × 173.95(V)	mm	
Number of pixels	1366 (H) × 768 (V)	pixels	
Pixel pitch	0.2265(H) × 0.2265 (V)	mm	
Pixel arrangement	RGB Vertical stripe		
Display colors	262K	colors	
Display mode	Normally White		
Dimensional outline	323.5 (H) × 192 (V) × 5.2 (D:max)	mm	
Weight	350 (max)	g	
Surface treatment	Glare (Clear Black) / Hard coating 3H		
Back-light	Upper edge side, 1-LED Lighting Bar type		Note 1
Power consumption	P <sub>D</sub> : 1.0 (max)	W	
	P <sub>BL</sub> : 3.0 (max)	W	
	P <sub>total</sub> : 4.0 (max)	W	

Notes : 1. LED Lighting Bar (40\*LED Array)

SPEC. NUMBER  
S

SPEC TITLE  
HT140WXB-101 Product Specification

PAGE  
5 OF 35

## 2.0 ABSOLUTE MAXIMUM RATINGS

The followings are maximum values which, if exceeded, may cause faulty operation or damage to the unit. The operational and non-operational maximum voltage and current values are listed in Table 2.

&lt; Table 2. Absolute Maximum Ratings &gt;

Ta=25+/-2°C

Parameter	Symbol	Min.	Max.	Unit	Remarks
Power Supply Voltage	$V_{DD}$	-0.3	4.0	V	Note 1
Logic Supply Voltage	$V_{IN}$	$V_{SS}-0.3$	$V_{DD}+0.3$	V	
Operating Temperature	$T_{OP}$	0	+50	°C	Note 2
Storage Temperature	$T_{ST}$	-20	+60	°C	

- Notes : 1. Permanent damage to the device may occur if maximum values are exceeded functional operation should be restricted to the condition described under normal operating conditions.
2. Temperature and relative humidity range are shown in the figure below.  
 95 % RH Max. ( 40 °C ≥ Ta)  
 Maximum wet - bulb temperature at 39 °C or less. (Ta > 40 °C) No condensation.

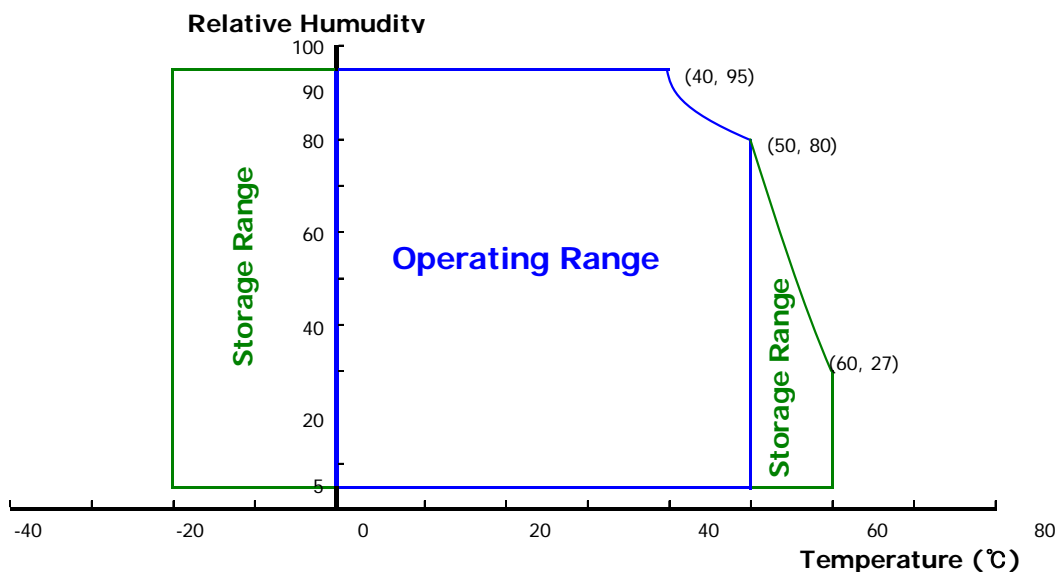

### 3.0 ELECTRICAL SPECIFICATIONS

#### 3.1 Electrical Specifications

&lt; Table 3. Electrical specifications &gt;

Ta=25+/-2°C

Parameter		Min.	Typ.	Max.	Unit	Remarks
Power Supply Voltage	V <sub>DD</sub>	3.0	3.3	3.6	V	Note 1
Permissible Input Ripple Voltage	V <sub>RF</sub>	-	-	100	mV	At V <sub>DD</sub> = 3.3V
Power Supply Current	I <sub>DD</sub>	-	203	303	mA	Note 1
Positive-going Input Threshold Voltage	V <sub>IT+</sub>	-	-	100	mV	V <sub>cm</sub> = 1.2V typ.
Negative-going Input Threshold Voltage	V <sub>IT-</sub>	-100	-	-	mV	
Differential Input Voltage	V <sub>ID</sub>	200	-	600	mV	
Power Consumption	P <sub>D</sub>	-	0.7	1.0	W	Note 1
	P <sub>BL</sub>	-	2.85	3.0	W	Note 2
	P <sub>total</sub>	-	3.55	4.0	W	

Notes : 1. The supply voltage is measured and specified at the interface connector of LCM.  
The current draw and power consumption specified is for 3.3V at 25°C.

a) Typ : Window XP pattern

b) Max : Vertical 2 line skip pattern

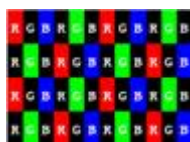

2. Calculated value for reference (V<sub>LED</sub> × I<sub>LED</sub>)

SPEC. NUMBER S	SPEC TITLE HT140WXB-101 Product Specification	PAGE 7 OF 35
-------------------	--	-----------------

### 3.0 ELECTRICAL SPECIFICATIONS

#### 3.2 Backlight Unit

&lt; Table 4. LED Driving guideline specifications &gt;

Ta=25+/-2°C

Parameter		Min.	Typ.	Max.	Unit	Remarks
LED Forward Voltage	$V_F$	3.0	3.2	3.4	V	-
LED Forward Current	$I_F$	-	20		mA	-
LED Power Consumption	$P_{LED}$		2.85	3.0	W	Note 1
LED Life-Time	N/A	15,000	-	-	Hour	$I_F = 20mA$
Power supply voltage for LED Driver	$V_{LED}$	6	12	21	V	
EN Control Level	Backlight on	2.0		5.0	V	
	Backlight off	0		1.0	V	
PWM Control Level	PWM High Level	2.0		5.0	V	
	PWM Low Level	0		0.1	V	
PWM Control Frequency	$F_{PWM}$	180	200	10,000	Hz	
Duty Ratio	-	20	-	100	%	

 Notes : 1. Calculator Value for reference  $I_{LED} \times V_{LED} = P_{LED}$ 

2. The LED Life-time define as the estimated time to 50% degradation of initial luminous.





# PRODUCT GROUP

REV

ISSUE DATE

TFT LCD PRODUCT

0

2010.2.11

## 4.0 OPTICAL SPECIFICATION

### 4.1 Overview

The test of Optical specifications shall be measured in a dark room (ambient luminance  $\leq 1$  lux and temperature =  $25 \pm 2^\circ\text{C}$ ) with the equipment of Luminance meter system (Goniometer system and TOPCON BM-5) and test unit shall be located at an approximate distance 50cm from the LCD surface at a viewing angle of  $\Theta$  and  $\Phi$  equal to  $0^\circ$ . We refer to  $\Theta \emptyset = 0$  ( $= \Theta 3$ ) as the 3 o'clock direction (the "right"),  $\Theta \emptyset = 90$  ( $= \Theta 12$ ) as the 12 o'clock direction ("upward"),  $\Theta \emptyset = 180$  ( $= \Theta 9$ ) as the 9 o'clock direction ("left") and  $\Theta \emptyset = 270$  ( $= \Theta 6$ ) as the 6 o'clock direction ("bottom"). While scanning  $\Theta$  and/or  $\emptyset$ , the center of the measuring spot on the Display surface shall stay fixed. The backlight should be operating for 30 minutes prior to measurement. VDD shall be  $3.3 \pm 0.3\text{V}$  at  $25^\circ\text{C}$ . Optimum viewing angle direction is 6 'clock.

### 4.2 Optical Specifications

<Table 5. Optical Specifications>

Parameter		Symbol	Condition	Min.	Typ.	Max.	Unit	Remark
Viewing Angle range	Horizontal	$\Theta_3$	CR > 10	40	-	-	Deg.	Note 1
		$\Theta_9$		40	-	-	Deg.	
	Vertical	$\Theta_{12}$		15	-	-	Deg.	
		$\Theta_6$		30	-	-	Deg.	
Luminance Contrast ratio		CR	$\Theta = 0^\circ$	500	600			Note 2
Luminance of White	5 Points	$Y_w$	$\Theta = 0^\circ$ $I_{LED} = 20\text{mA}$	180	200	-	cd/m <sup>2</sup>	Note 3
White Luminance uniformity	5 Points	$\Delta Y_5$		80	-	-		Note 4
	13 Points	$\Delta Y_{13}$		65	-	-		
White Chromaticity		$x_w$	$\Theta = 0^\circ$	0.283	0.313	0.343		Note 5
		$y_w$		0.299	0.329	0.359		
Reproduction of color	Red	$x_R$	$\Theta = 0^\circ$	0.545	0.575	0.605		
		$y_R$		0.305	0.335	0.365		
	Green	$x_G$		0.305	0.335	0.365		
		$y_G$		0.555	0.585	0.615		
	Blue	$x_B$		0.125	0.155	0.185		
		$y_B$		0.090	0.120	0.150		
Response Time (Rising + Falling)		$T_{RT}$	$T_a = 25^\circ\text{C}$ $\Theta = 0^\circ$	-	8	16	ms	Note 6
Cross Talk		CT	$\Theta = 0^\circ$	-	-	2.0	%	Note 7

SPEC. NUMBER  
S

SPEC TITLE  
HT140WXB-101 Product Specification

PAGE  
9 OF 35



Notes : 1. Viewing angle is the angle at which the contrast ratio is greater than 10. The viewing angles are determined for the horizontal or 3, 9 o'clock direction and the vertical or 6, 12 o'clock direction with respect to the optical axis which is normal to the LCD surface (see FIGURE 1).

2. Contrast measurements shall be made at viewing angle of  $\Theta = 0$  and at the center of the LCD surface. Luminance shall be measured with all pixels in the view field set first to white, then to the dark (black) state .  
(see FIGURE 1) Luminance Contrast Ratio (CR) is defined mathematically.

$$CR = \frac{\text{Luminance when displaying a white raster}}{\text{Luminance when displaying a black raster}}$$

3. Center Luminance of white is defined as luminance values of 5 point average across the LCD surface. Luminance shall be measured with all pixels in the view field set first to white. This measurement shall be taken at the locations shown in FIGURE 2 for a total of the measurements per display.

4. The White luminance uniformity on LCD surface is then expressed as :  $\Delta Y = \text{Minimum Luminance of 5(or 13) points} / \text{Maximum Luminance of 5(or 13) points}$  (see FIGURE 2 and FIGURE 3).

5. The color chromaticity coordinates specified in Table 5 shall be calculated from the spectral data measured with all pixels first in red, green, blue and white. Measurements shall be made at the center of the panel.

6. The electro-optical response time measurements shall be made as FIGURE 4 by switching the "data" input signal ON and OFF. The times needed for the luminance to change from 10% to 90% is Tr, and 90% to 10% is Td.

7. Cross-Talk of one area of the LCD surface by another shall be measured by comparing the luminance (YA) of a 25mm diameter area, with all display pixels set to a gray level, to the luminance (YB) of that same area when any adjacent area is driven dark. (See FIGURE 5).

**4.3 Optical measurements**

**Figure 1. Measurement Set Up**

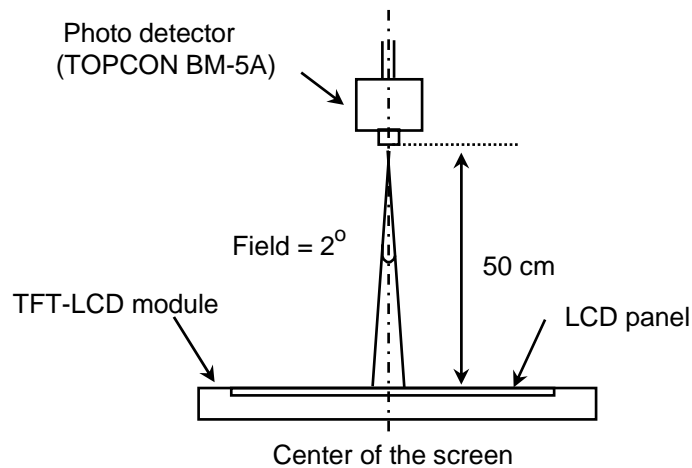

Optical characteristics measurement setup

**Figure 2. White Luminance and Uniformity Measurement Locations (5 points)**

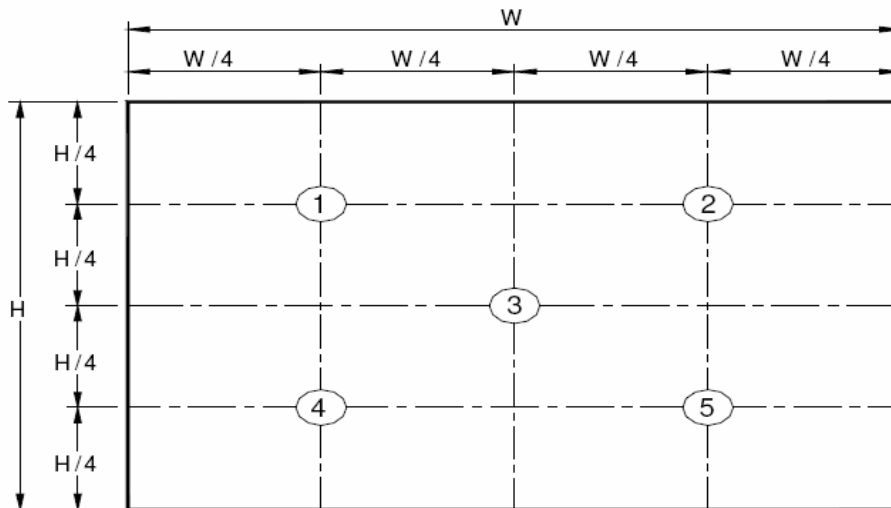

Center Luminance of white is defined as luminance values of center 5 points across the LCD surface. Luminance shall be measured with all pixels in the view field set first to white. This measurement shall be taken at the locations shown in FIGURE 2 for a total of the measurements per display.

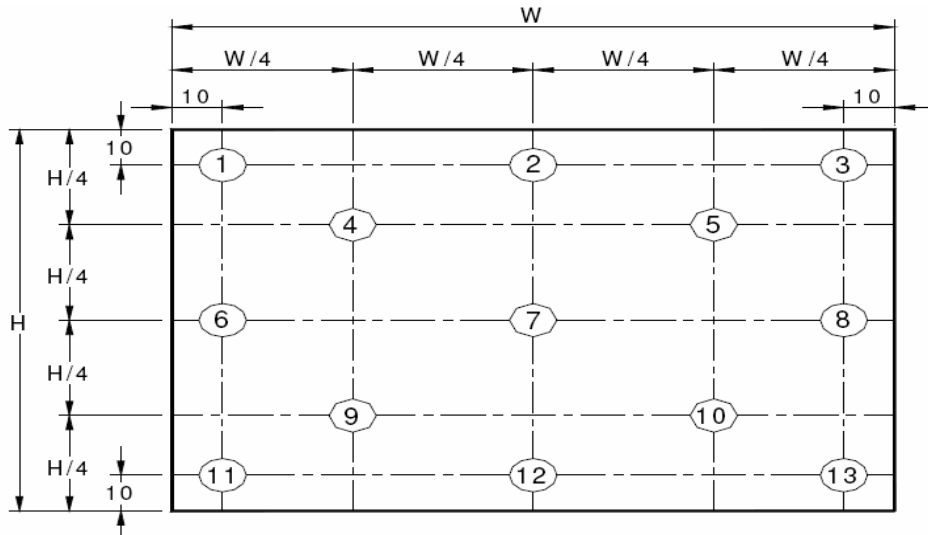
**Figure 3. Uniformity Measurement Locations (13 points)**

The White luminance uniformity on LCD surface is then expressed as :  $\Delta Y5 = \text{Minimum Luminance of five points} / \text{Maximum Luminance of five points}$  (see FIGURE 2) ,  $\Delta Y13 = \text{Minimum Luminance of 13 points} / \text{Maximum Luminance of 13 points}$  (see FIGURE 3).

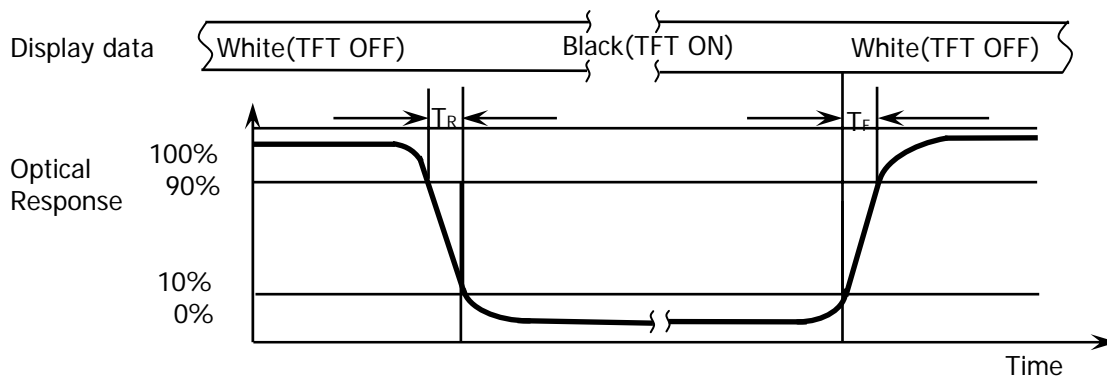
**Figure 4. Response Time Testing**

The electro-optical response time measurements shall be made as shown in FIGURE 4 by switching the “data” input signal ON and OFF. The times needed for the luminance to change from 10% to 90% is  $T_d$  and 90% to 10% is  $T_r$ .

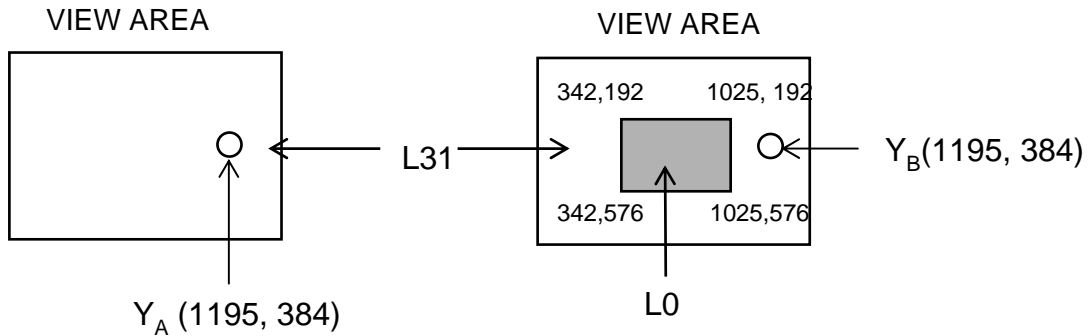
**Figure 5. Cross Modulation Test Description**

$$\text{Cross-Talk (\%)} = \left| \frac{Y_B - Y_A}{Y_B} \right| \times 100$$

Where:

$Y_A$  = Initial luminance of measured area (cd/m<sup>2</sup>)

$Y_B$  = Subsequent luminance of measured area (cd/m<sup>2</sup>)

The location measured will be exactly the same in both patterns

Cross-Talk of one area of the LCD surface by another shall be measured by comparing the luminance ( $Y_A$ ) of a 25mm diameter area, with all display pixels set to a gray level, to the luminance ( $Y_B$ ) of that same area when any adjacent area is driven dark (Refer to FIGURE 5).

## 5.0 INTERFACE CONNECTION.

### 5.1 Electrical Interface Connection

The electronics interface connector is I-PEX 20455-040E-12 or Compatible or equivalent. The mating connector part number is I-PEX 20455-040T-11 or Compatible. The connector interface pin assignments are listed in Table 6.

<Table 6. Pin Assignments for the Interface Connector>

Terminal	Symbol	Functions
Pin No.	Symbol	Description
1	DIAG_LOOP	Connect to Pin34
2	VDDIN	Power Supply, 3.3V (typ.)
3	VDDIN	Power Supply, 3.3V (typ.)
4	VDC	VDC 3.3Vpower for EDID
5	BISTC	BIST control(Note.1)
6	CLK EDID	EDID Clock
7	Data EDID	EDID Data
8	RxIN0-	Transmission Data of 0 Negative -
9	RxIN0+	Transmission Data of 0 Positive +
10	GND	Ground
11	RxIN1-	Transmission Data of 1 Negative -
12	RxIN1+	Transmission Data of 1 Positive +
13	GND	Ground
14	RxIN2-	Transmission Data of 2 Negative -
15	RxIN2+	Transmission Data of 2 Positive +
16	GND	Ground
17	RxCLKIN-	Sampling Clock of Negative -
18	RxCLKIN+	Sampling Clock of Positive +
19	GND	Ground
20	NC	No Connection
21	NC	No Connection
22	GND	Ground
23	NC	No Connection
24	NC	No Connection
25	GND	Ground
26	(CE)	LCD internal use only
27	(CTL)	
28	GND	Ground
29	NC	No Connection
30	NC	No Connection



京东方  
BOE

# PRODUCT GROUP

TFT LCD PRODUCT

REV

0

ISSUE DATE

2010.2.11

Terminal	Symbol	Functions
Pin No.	Symbol	Description
31	VLED_GND	LED Ground
32	VLED_GND	LED Ground
33	VLED_GND	LED Ground
34	DIAG_LOOP	Connect to Pin1
35	PWM	System PWM Signal Input
36	LED_EN	LED enable pin(+3.3V Input)
37	NC	No Connection (Reserve)
38	VLED	LED Power Supply 6V-21V
39	VLED	LED Power Supply 6V-21V
40	VLED	LED Power Supply 6V-21V

Note.1

-BIST="H (3.3V)" : Display BIST pattern @ No LVDS CLK or DE

(white->black->red->green->blue->white...)

-BIST="L(GND or NC)" : Display black pattern @ No LVDS CLK or DE

SPEC. NUMBER

S

SPEC TITLE

HT140WXB-101 Product Specification

PAGE

15 OF 35

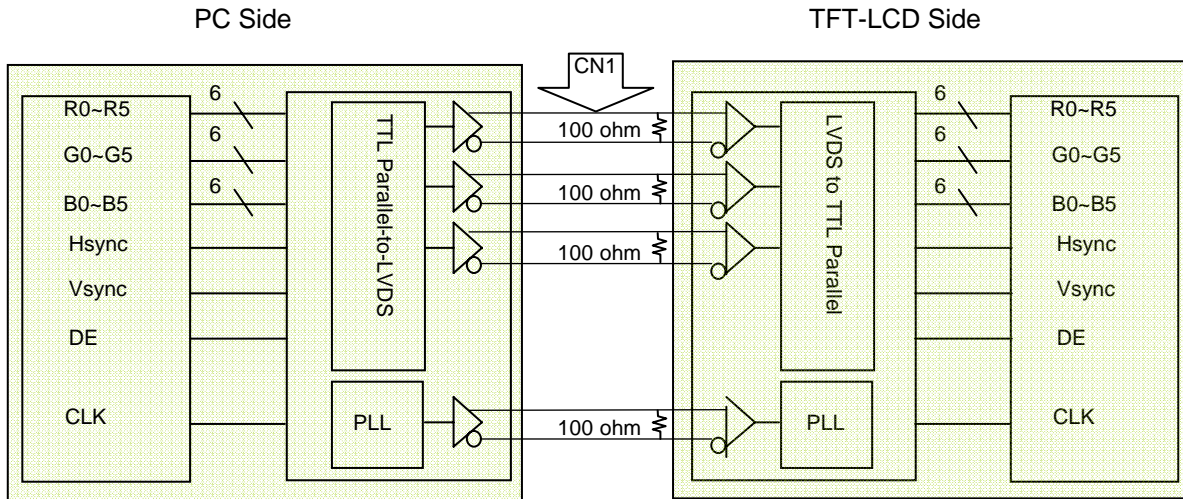
**5-2. LVDS Interface**

Note. Transmitter : Thine THC63LVDM63A or equivalent.  
Transmitter is not contained in Module.

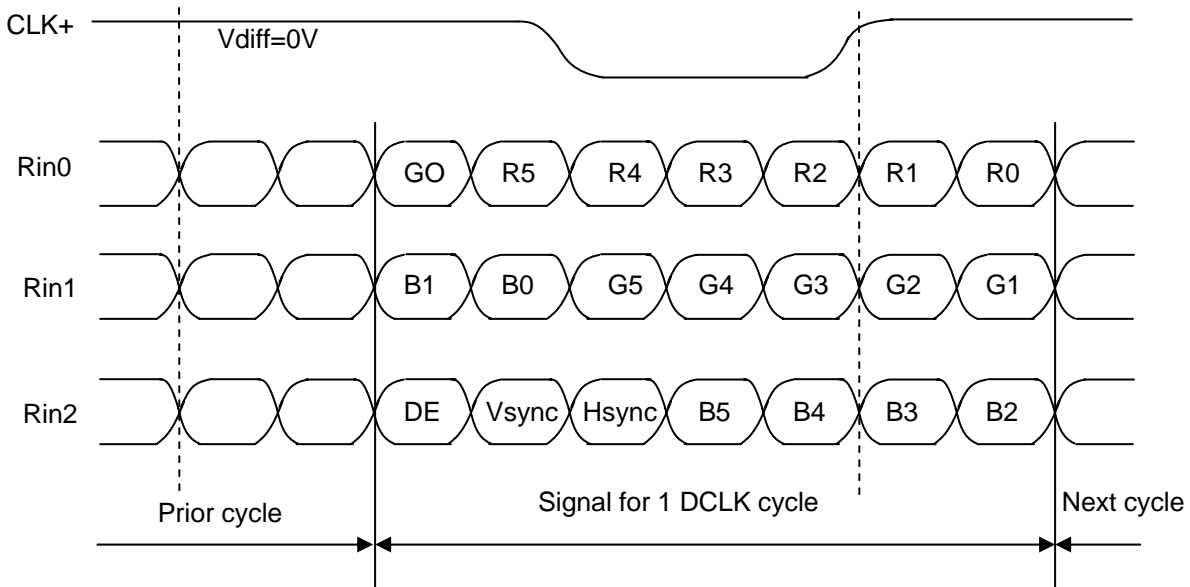
**5.3.LVDS Input signal**

Note. Pin connection in case of using Thine THC63LVDM63A



### 5.3 Data Input Format

<Table 6. Pin Assignments for the Interface Connector>

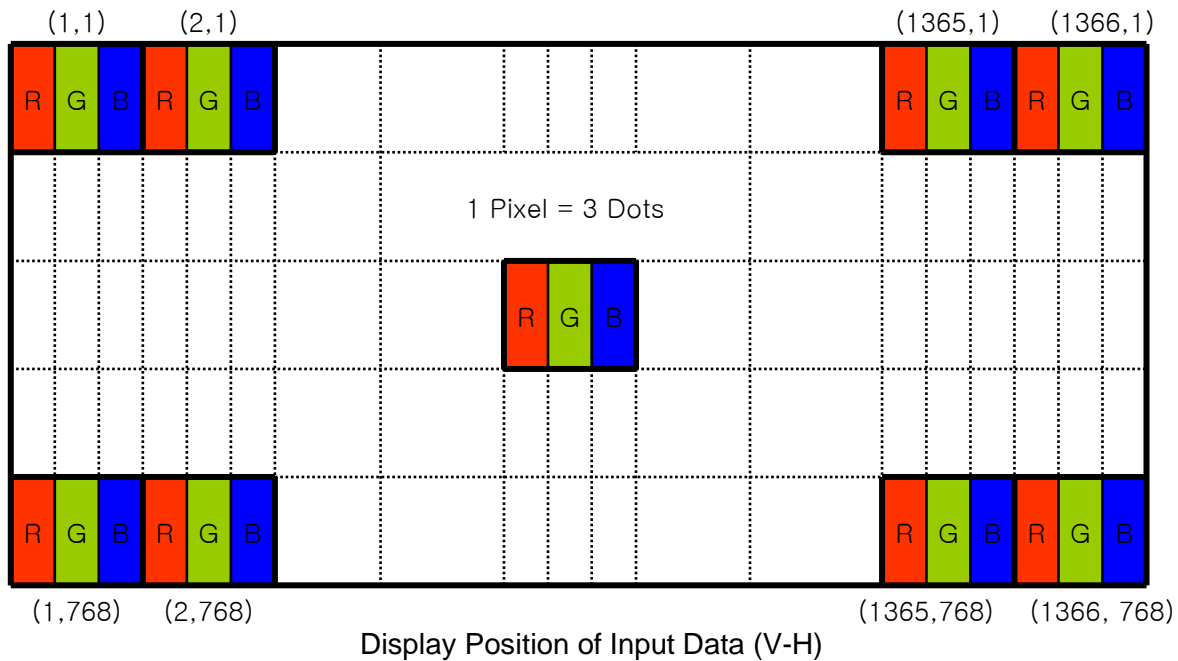

### 5.4 Back-light & LCM Interface Connection

Interface Connector: MS24022P10 or Equivalent

<Table 7. Pin Assignments for the BLU & LCM Connector>

Pin No.	Symbol	Description	Pin No.	Symbol	Description
1	Vout	LED anode connection	6	LED1	LED cathode connection
2	Vout	LED anode connection	7	LED2	LED cathode connection
3	Vout	LED anode connection	8	LED3	LED cathode connection
4	NC	No Connection	9	LED4	LED cathode connection
5	NC	No Connection	10	LED5	LED cathode connection

## 6.0 SIGNAL TIMING SPECIFICATION

6.1 The HT140WXB-101 is operated by the DE only.

Item		Symbols	Min	Typ	Max	Unit
Clock	Frequency	1/Tc	40	69.3	-	MHz
	High Time	Tch	-	4/7	-	Tc
	Low Time	Tcl	-	3/7	-	Tc
Frame Period		Tv	776	788	800	lines
			-	60	-	Hz
			-	16.7	-	ms
Vertical Display Period		Tvd	768	768	768	lines
One line Scanning Period		Th	1406	1466	1526	clocks
Horizontal Display Period		Thd	1366	1366	1366	clocks

### 6.2 LVDS Rx Interface Timing Parameter

The specification of the LVDS Rx interface timing parameter is shown in Table 8.

<Table 8. LVDS Rx Interface Timing Specification>

Item	Symbol	Min	Typ	Max	Unit	Remark
CLKIN Period	tRCIP	-	13.83	25	nsec	
CLK Difference	tCdiff	-tRCIP*(3/7)	0	+tRCIP*(3/7)	nsec	
Input Data 0	tRIP1	-0.4	0.0	+0.4	nsec	
Input Data 1	tRIP0	tRCIP/7-0.4	tRCIP/7	tRCIP/7+0.4	nsec	
Input Data 2	tRIP6	2 × tRCIP/7-0.4	2 × tRCIP/7	2 × tRCIP/7+0.4	nsec	
Input Data 3	tRIP5	3 × tRCIP/7-0.4	3 × tRCIP/7	3 × tRCIP/7+0.4	nsec	
Input Data 4	tRIP4	4 × tRCIP/7-0.4	4 × tRCIP/7	4 × tRCIP/7+0.4	nsec	
Input Data 5	tRIP3	5 × tRCIP/7-0.4	5 × tRCIP/7	5 × tRCIP/7+0.4	nsec	
Input Data 6	tRIP2	6 × tRCIP/7-0.4	6 × tRCIP/7	6 × tRCIP/7+0.4	nsec	

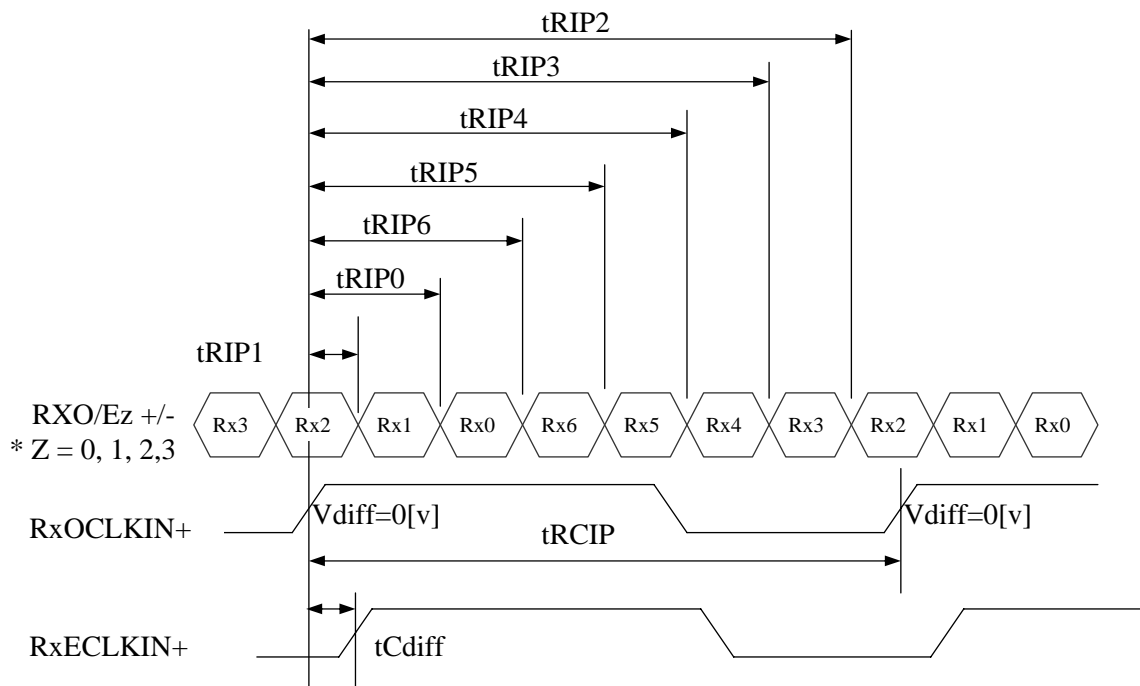

$$* V_{diff} = (RXO/Ez+) - (RXO/Ez-), \dots, (RXO/ECLK+) - (RXO/ECLK-)$$

## 7.0 SIGNAL TIMING WAVEFORMS OF INTERFACE SIGNAL

### 7.1 Sync Timing Waveforms

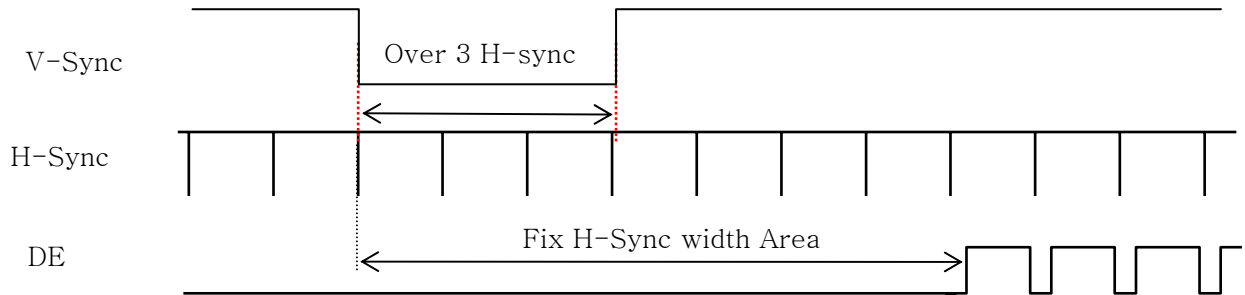

- 1) Need over 3 H-sync during V-Sync Low
- 2) Fix H-Sync width from V-Sync falling edge to first rising edge

### 7.2 Vertical Timing Waveforms

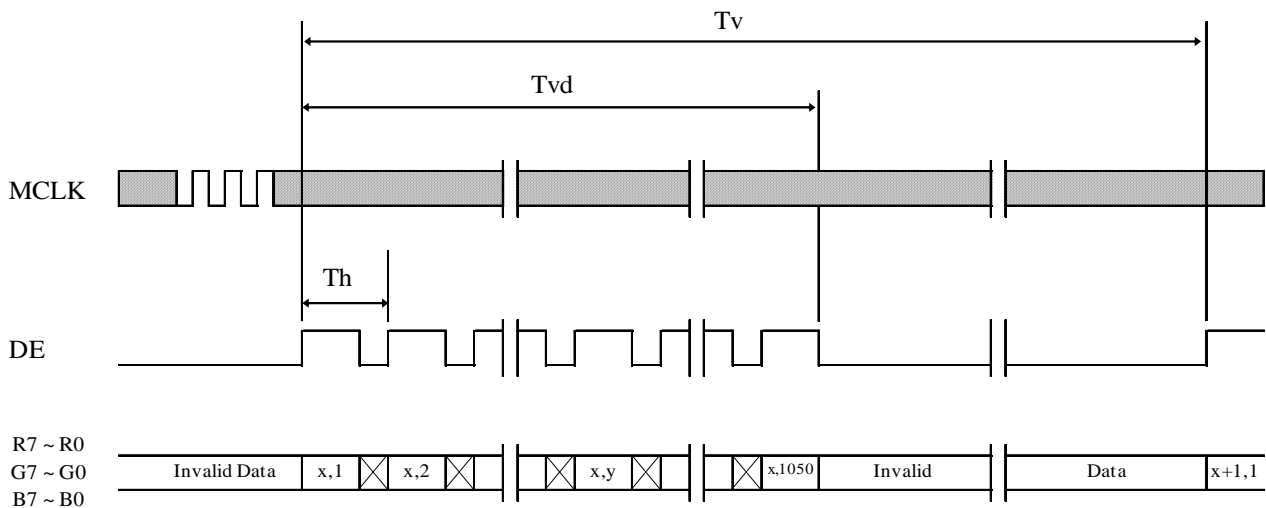

### 7.3 Horizontal Timing Waveforms

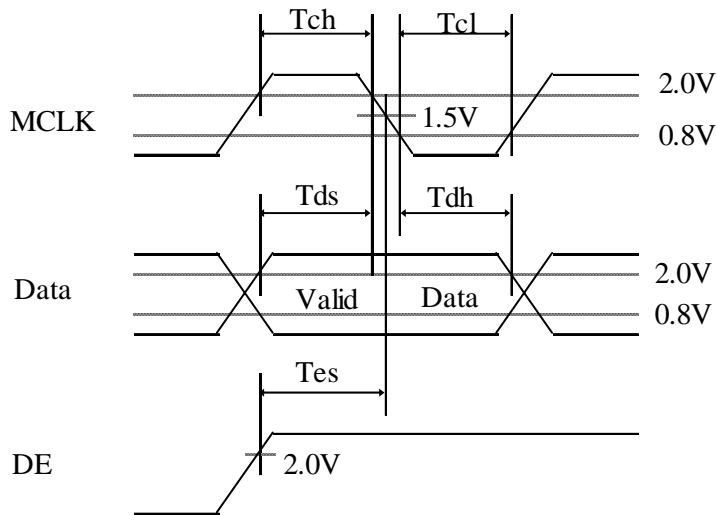
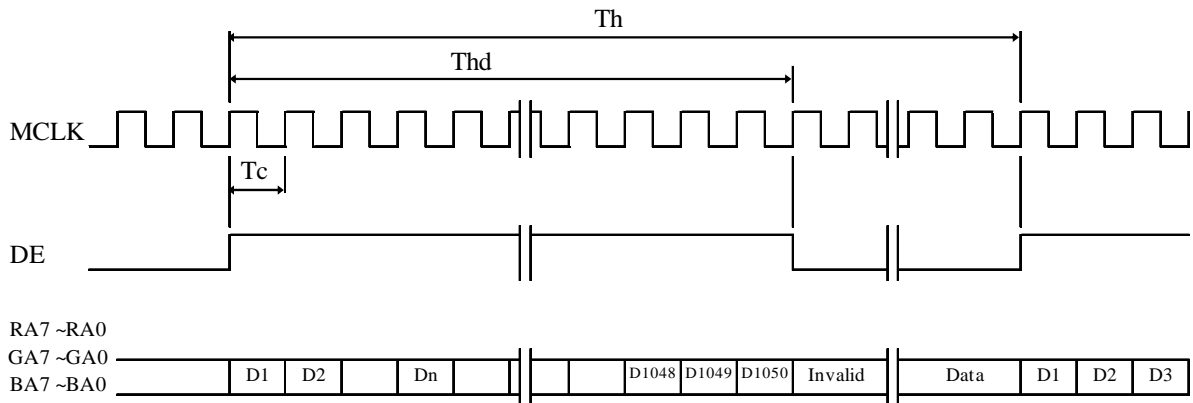

**8.0 INPUT SIGNALS, BASIC DISPLAY COLORS & GRAY SCALE OF COLORS**

	Colors & Gray scale	Data signal																	
		R0	R1	R2	R3	R4	R5	G0	G1	G2	G3	G4	G5	B0	B1	B2	B3	B4	B5
Basic colors	Black	0	0	0	0	0	0	0	0	0	0	0	0	0	0	0	0	0	0
	Blue	0	0	0	0	0	0	0	0	0	0	0	0	1	1	1	1	1	1
	Green	0	0	0	0	0	0	1	1	1	1	1	1	0	0	0	0	0	0
	Light Blue	0	0	0	0	0	0	1	1	1	1	1	1	1	1	1	1	1	1
	Red	1	1	1	1	1	1	0	0	0	0	0	0	0	0	0	0	0	0
	Purple	1	1	1	1	1	1	0	0	0	0	0	0	1	1	1	1	1	1
	Yellow	1	1	1	1	1	1	1	1	1	1	1	1	0	0	0	0	0	0
	White	1	1	1	1	1	1	1	1	1	1	1	1	1	1	1	1	1	1
Gray scale of Red	Black	0	0	0	0	0	0	0	0	0	0	0	0	0	0	0	0	0	0
	△	1	0	0	0	0	0	0	0	0	0	0	0	0	0	0	0	0	0
	Darker	0	1	0	0	0	0	0	0	0	0	0	0	0	0	0	0	0	0
	△																		
	▽																		
	Brighter	1	0	1	1	1	1	0	0	0	0	0	0	0	0	0	0	0	0
	▽	0	1	1	1	1	1	0	0	0	0	0	0	0	0	0	0	0	0
Red	1	1	1	1	1	1	0	0	0	0	0	0	0	0	0	0	0	0	
Gray scale of Green	Black	0	0	0	0	0	0	0	0	0	0	0	0	0	0	0	0	0	0
	△	0	0	0	0	0	0	1	0	0	0	0	0	0	0	0	0	0	0
	Darker	0	0	0	0	0	0	0	1	0	0	0	0	0	0	0	0	0	0
	△																		
	▽																		
	Brighter	0	0	0	0	0	0	1	0	1	1	1	1	0	0	0	0	0	0
	▽	0	0	0	0	0	0	0	1	1	1	1	1	0	0	0	0	0	0
Green	0	0	0	0	0	0	1	1	1	1	1	1	0	0	0	0	0	0	
Gray scale of Blue	Black	0	0	0	0	0	0	0	0	0	0	0	0	0	0	0	0	0	0
	△	0	0	0	0	0	0	0	0	0	0	0	0	1	0	0	0	0	0
	Darker	0	0	0	0	0	0	0	0	0	0	0	0	0	1	0	0	0	0
	△																		
	▽																		
	Brighter	0	0	0	0	0	0	0	0	0	0	0	0	1	0	1	1	1	1
	▽	0	0	0	0	0	0	0	0	0	0	0	0	0	1	1	1	1	1
Blue	0	0	0	0	0	0	0	0	0	0	0	0	1	1	1	1	1	1	
Gray scale of White & Black	Black	0	0	0	0	0	0	0	0	0	0	0	0	0	0	0	0	0	0
	△	1	0	0	0	0	0	1	0	0	0	0	0	1	0	0	0	0	0
	Darker	0	1	0	0	0	0	0	1	0	0	0	0	0	1	0	0	0	0
	△																		
	▽																		
	Brighter	1	0	1	1	1	1	1	0	1	1	1	1	1	0	1	1	1	1
	▽	0	1	1	1	1	1	0	1	1	1	1	1	0	1	1	1	1	1
White	1	1	1	1	1	1	1	1	1	1	1	1	1	1	1	1	1	1	

## 9.0 POWER SEQUENCE

To prevent a latch-up or DC operation of the LCD module, the power on/off sequence shall be as shown in below

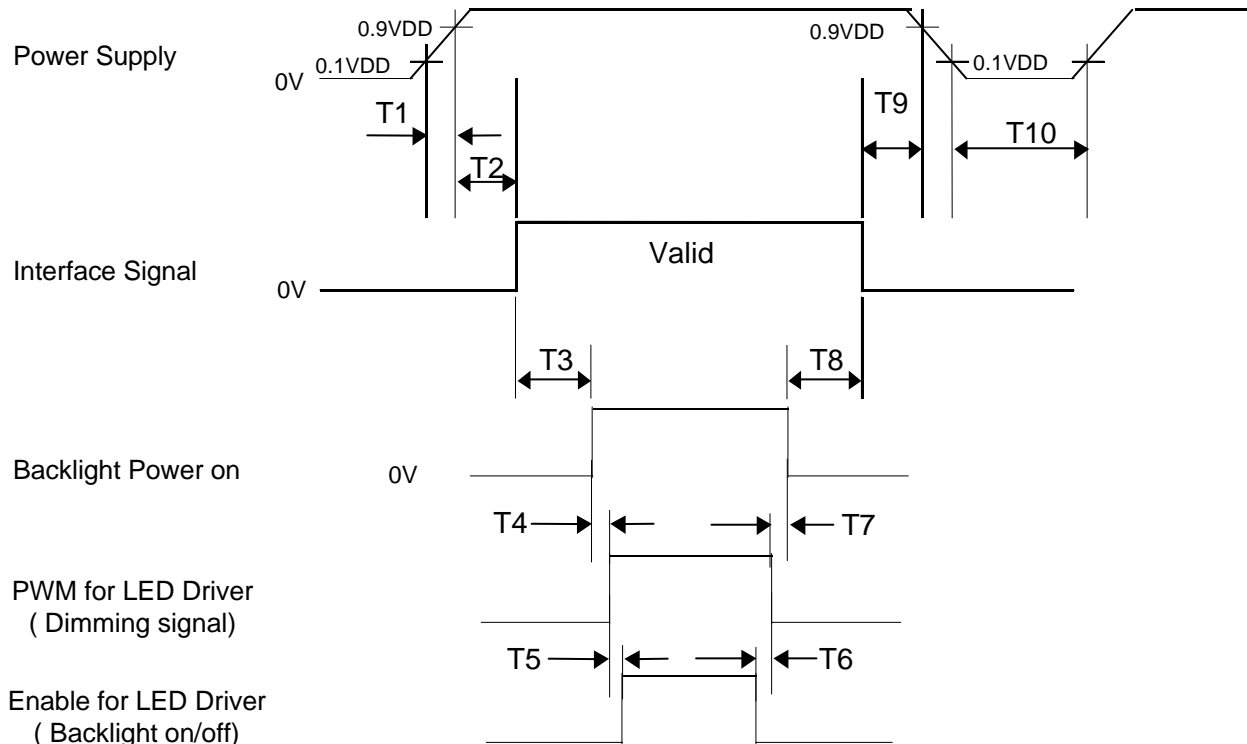

- $T1 \leq 10 \text{ ms}$
- $0 \text{ ms} \leq T2 \leq 50 \text{ ms}$
- $200 \text{ ms} \leq T3$
- $10 \text{ ms} \leq T4$
- $10 \text{ ms} \leq T5$
- $0 \text{ ms} \leq T6$
- $10 \text{ ms} \leq T7$
- $200 \text{ ms} \leq T8$
- $0 \text{ ms} \leq T9 \leq 50 \text{ ms}$
- $1 \text{ s} \leq T10$

### Notes:

- When the power supply VDD is 0V, keep the level of input signals on the low or keep high impedance.
- Do not keep the interface signal high impedance when power is on. Back Light must be turn on after power for logic and interface signal are valid.



## PRODUCT GROUP

REV

ISSUE DATE

TFT LCD PRODUCT

0

2010.2.11

### 10.0 Connector Description

Physical interface is described as for the connector on LCM.

These connectors are capable of accommodating the following signals and will be following components.

#### 10.1 TFT LCD Module

Connector Name /Description	For Signal Connector
Manufacturer	IPEX or Compatible
Type/ Part Number	I-PEX 20455-040E-12 or Compatible
Mating housing/ Part Number	I-PEX 20455-040T-11 or Compatible

SPEC. NUMBER

S

SPEC TITLE

HT140WXB-101 Product Specification

PAGE

24 OF 35



## 11.0 MECHANICAL CHARACTERISTICS

### 11.1 Dimensional Requirements

FIGURE 6 shows mechanical outlines for the model HT140WXB-101.  
Other parameters are shown in Table 9.

<Table 9. Dimensional Parameters>

Parameter	Specification	Unit
Active Area	309.40 (H) × 173.95 (V)	
Number of pixels	1366 (H) X 768 (V) (1 pixel = R + G + B dots)	
Pixel pitch	0.2265 (H) X 0.2265 (V)	
Pixel arrangement	RGB Vertical stripe	
Display colors	262K	
Display mode	Normally white	
Dimensional outline	323.5*192*5.2 (max)	mm
Weight	350 (max)	gram
Back Light	Connector : MS24022P10	
	LED, Horizontal-LED Array type	

### 10.2 Mounting

See FIGURE 6.

### 10.3 Glare and Polarizer Hardness.

The surface of the LCD has an glare coating to maximize readability and hard coating to reduce scratching.

### 10.4 Light Leakage

There shall not be visible light from the back-lighting system around the edges of the screen as seen from a distance 50cm from the screen with an overhead light level of 350lux.

## 12.0 RELIABILITY TEST

The Reliability test items and its conditions are shown in below.

<Table 10. Reliability test>

No	Test Items	Conditions
1	High temperature storage test	Ta = 60 °C, 240 hrs
2	Low temperature storage test	Ta = -20 °C, 240 hrs
3	High temperature & high humidity operation test	Ta = 50 °C, 80%RH, 240 hrs
4	High temperature operation test	Ta = 50 °C, 240 hrs
5	Low temperature operation test	Ta = 0 °C, 240 hrs
6	Thermal shock	Ta = -20 °C ↔ 60 °C (0.5 hr), 100 cycle
7	Vibration test (non-operating)	1.5G, 10~500Hz Sine X,Y,Z / Sweep rate : 0.5hour
8	Shock test (non-operating)	220G, Half Sine Wave 2msec ±X, ±Y, ±Z Once for each direction
9	Electro-static discharge test (non-operating)	Air : 150 pF, 330Ω, 15 KV Contact : 150 pF, 330Ω, 8 KV

## 13.0 HANDLING & CAUTIONS

### (1) Cautions when taking out the module

- Pick the pouch only, when taking out module from a shipping package.

### (2) Cautions for handling the module

- As the electrostatic discharges may break the LCD module, handle the LCD module with care. Peel a protection sheet off from the LCD panel surface as slowly as possible.
- As the LCD panel and back - light element are made from fragile glass material, impulse and pressure to the LCD module should be avoided.
- As the surface of the polarizer is very soft and easily scratched, use a soft dry cloth without chemicals for cleaning.
- Do not pull the interface connector in or out while the LCD module is operating.
- Put the module display side down on a flat horizontal plane.
- Handle connectors and cables with care.

### (3) Cautions for the operation

- When the module is operating, do not lose CLK, ENAB signals. If any one of these signals is lost, the LCD panel would be damaged.
- Obey the supply voltage sequence. If wrong sequence is applied, the module would be damaged.



## PRODUCT GROUP

REV

ISSUE DATE

TFT LCD PRODUCT

0

2010.2.11

### (4) Cautions for the atmosphere

- Dew drop atmosphere should be avoided.
- Do not store and/or operate the LCD module in a high temperature and/or humidity atmosphere. Storage in an electro-conductive polymer packing pouch and under relatively low temperature atmosphere is recommended.

### (5) Cautions for the module characteristics

- Do not apply fixed pattern data signal to the LCD module at product aging.
- Applying fixed pattern for a long time may cause image sticking.

### (6) Other cautions

- Do not disassemble and/or re-assemble LCD module.
- Do not re-adjust variable resistor or switch etc.
- When returning the module for repair or etc., Please pack the module not to be broken. We recommend to use the original shipping packages.

## 14.0 LABEL

### (1) Product label



1            2            3            4            5                                  6                                  7

X	X	X	X	X	X	1	0	0	X	X	X	X	X	X	X	X
---	---	---	---	---	---	---	---	---	---	---	---	---	---	---	---	---

Type designation

No 5. Month (1, 2, 3, ..., 9, X, Y, Z)

No 1. Control Number

No 6. Product Identification (FG)

No 2. Rank / Grade

No 7. Serial Number

No 3. Line classification (BOE OT:A/BC)

No 4. Year (10 : 2010, 11: 2011, ...)

SPEC. NUMBER

SPEC TITLE

PAGE

S

HT140WXB-101 Product Specification

27 OF 35



**PRODUCT GROUP**

REV

ISSUE DATE

TFT LCD PRODUCT

0

2010.2.11

(2) High voltage caution label

	<p>HIGH VOLTAGE CAUTION</p>	<p>COLD CATHODE FLUORESCENT LAMP IN LCD PANEL CONTAINS A SMALL AMOUNT OF MERCURY. PLEASE FOLLOW LOCAL OR- DINANCES OR REGULATIONS FOR DISPOSAL.</p>
	<p>RISK OF ELECTRIC SHOCK, DISCONNECT THE ELECTRIC POWER BEFORE SERVICING</p>	

(3) Box label

Label Size: 110 mm (L) × 56 mm (W)

Contents

Model: HT140WXB-101

Q`ty: Module Q`ty in one box

Serial No.: Box Serial No. See next figure for detail description.

Date: Packing Date

Internal use of Product



<u>00</u>	<u>0</u>	<u>0</u>	<u>00</u>	<u>0</u>	<u>0000</u>	<u>000000</u>
Type	Grade	Line	Year	Month	Internal use	Serial No

SPEC. NUMBER  
S

SPEC TITLE  
HT140WXB-101 Product Specification

PAGE  
28 OF 35

## 15.0 PACKING INFORMATION

### 15.1 Packing order

Put Pad into the box.



As shown in the figure, place the paper spacer and modules bundled by PE bag in the box.

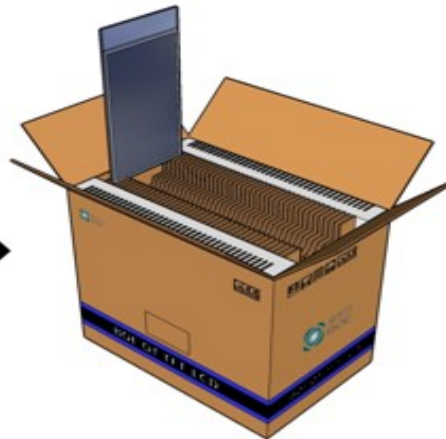

After sealing the box, attach Packing Label on the attach position sign area of the box.

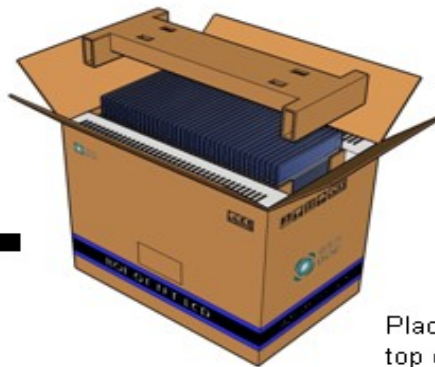

Place Cover Pad on the top of the box.

### 15.2 Notes

- Box Dimension: 526mm(W) x 346mm(D) x 448mm(H)
- Package Quantity in one Box: 38pcs
- Total Weight: 16kg

## 16.0 MECHANICAL OUTLINE DIMENSION

Figure 6. TFT-LCD Module Outline Dimension (Front View)

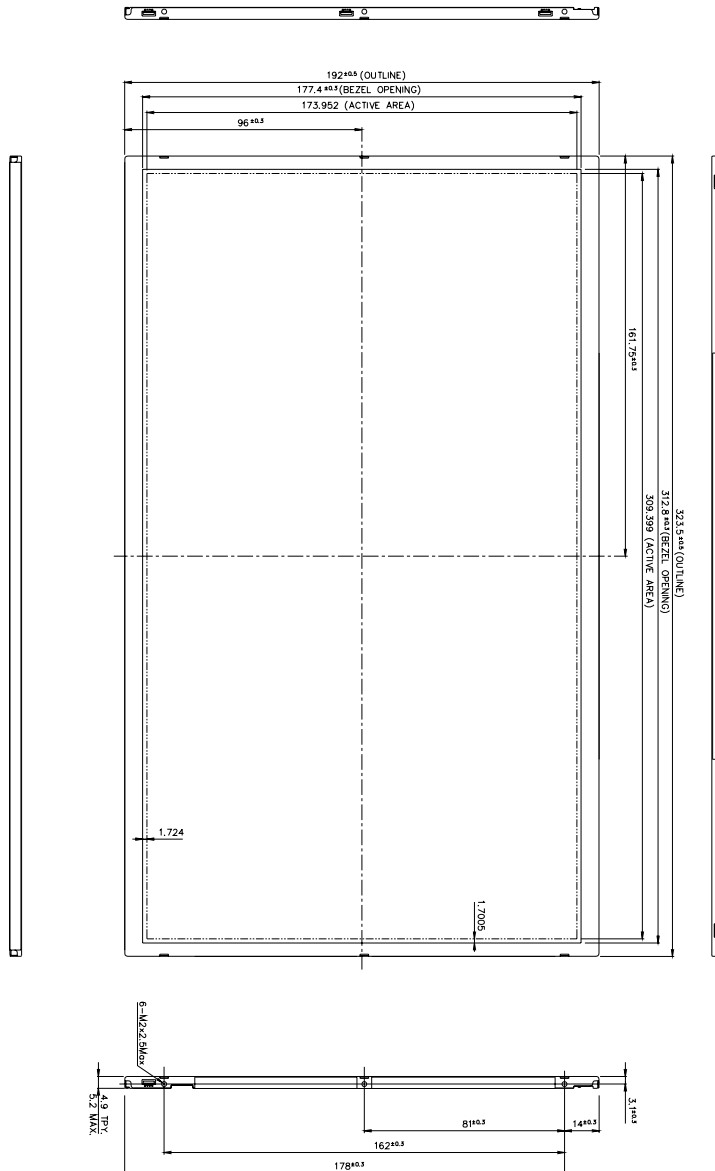

SPEC. NUMBER  
S

SPEC TITLE  
HT140WXB-101 Product Specification

PAGE  
30 OF 35

Figure 7. TFT-LCD Module Outline Dimensions (Rear view)

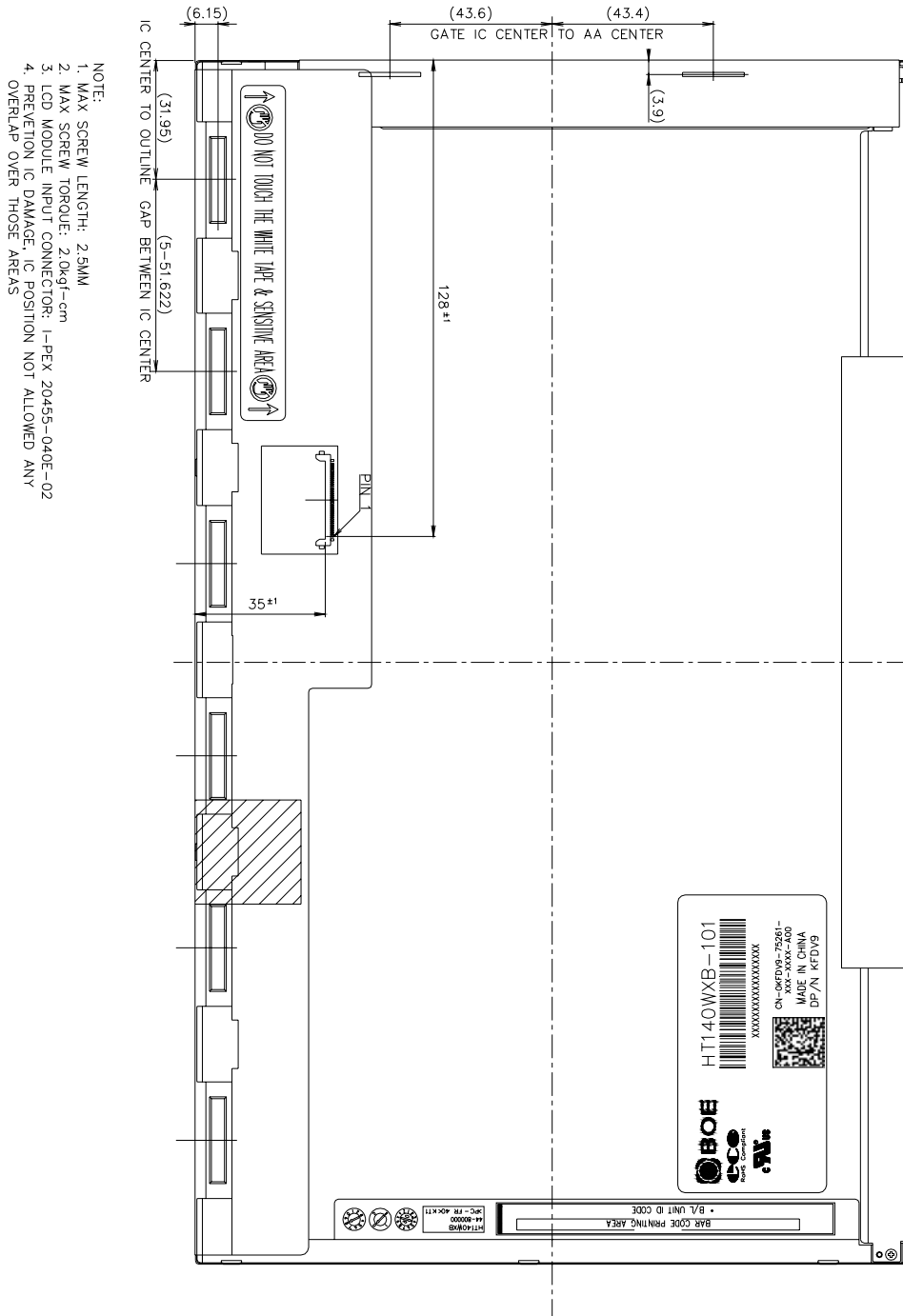



# PRODUCT GROUP

REV

ISSUE DATE

TFT LCD PRODUCT

0

2010.2.11

## 17.0 EDID Table

Address (HEX)	Function	Hex	Dec	Input values.	Notes
00	Header	00	0	0	EDID Header
01		FF	255	255	
02		FF	255	255	
03		FF	255	255	
04		FF	255	255	
05		FF	255	255	
06		FF	255	255	
07		00	0	0	
08	ID Manufacturer Name	09	9	BOE	ID = BOE
09		E5	229		
0A	ID Product Code	8E	142	1422	ID = 1422
0B		05	5		
0C	32-bit serial No.	00	0		
0D		00	0		
0E		00	0		
0F		00	0		
10	Week of manufacture	1	1	1	
11	Year of Manufacture	14	20	2010	Manufactured in 2010
12	EDID Structure Ver.	01	1	1	EDID Ver 1.0
13	EDID revision #	04	4	4	EDID Rev. 0.4
14	Video input definition	80	128	-	
15	Max H image size	1F	31	31	31 cm (Approx)
16	Max V image size	11	17	17	17 cm (Approx)
17	Display Gamma	78	120	2.2	Gamma curve = 2.2
18	Feature support	0A	10		RGB display, Preferred Timming mode
19	Red/Green low bits	3F	63	-	Red / Green Low Bits
1A	Blue/White low bits	A0	160	-	Blue / White Low Bits
1B	Red x high bits	93	147	0.575	Red (x) = 10010011 (0.575)
1C	Red y high bits	55	85	0.335	Red (y) = 01010101 (0.335)
1D	Green x high bits	55	85	0.335	Green (x) = 01010101 (0.335)
1E	Green y high bits	95	149	0.585	Green (y) = 10010101 (0.585)
1F	Blue x high bits	27	39	0.155	Blue (x) = 00100111 (0.155)
20	Blue y high bits	1E	30	0.120	Blue (y) = 00011110 (0.12)
21	White x high bits	50	80	0.313	White (x) = 01010000 (0.313)
22	White y high bits	54	84	0.329	White (y) = 01010100 (0.329)

SPEC. NUMBER  
S

SPEC TITLE  
HT140WXB-101 Product Specification

PAGE  
32 OF 35





# PRODUCT GROUP

REV

ISSUE DATE

TFT LCD PRODUCT

0

2010.2.11

Address (HEX)	Function	Hex	Dec	crc	Input values.	Notes
23	Established timing 1	00	0		-	
24	Established timing 2	00	0		-	
25	Established timing 3	00	0		-	
26	Standard timing #1	01	1			Not Used
27		01	1			
28	Standard timing #2	01	1			Not Used
29		01	1			
2A	Standard timing #3	01	1			Not Used
2B		01	1			
2C	Standard timing #4	01	1			Not Used
2D		01	1			
2E	Standard timing #5	01	1			Not Used
2F		01	1			
30	Standard timing #6	01	1			Not Used
31		01	1			
32	Standard timing #7	01	1			Not Used
33		01	1			
34	Standard timing #8	01	1			Not Used
35		01	1			
36	Detailed timing/monitor descriptor #1	13	19		69.31	69.31MHz Main clock
37		1B	27			
38		56	86		1366	Hor Active = 1366
39		64	100		100	Hor Blanking = 100
3A		50	80		-	4 bits of Hor. Active + 4 bits of Hor. Blanking
3B		00	0		768	Ver Active = 768
3C		14	20		20	Ver Blanking = 20
3D		30	48		-	4 bits of Ver. Active + 4 bits of Ver. Blanking
3E		30	48		48	Hor Sync Offset = 48
3F		20	32		32	H Sync Pulse Width = 32
40		36	54		3	V sync Offset = 3 line
41		00	0		6	V Sync Pulse width : 6 line
42		35	53		309	Horizontal Image Size = 309 mm (Low 8 bits)
43		AD	173		173	Vertical Image Size = 173 mm (Low 8 bits)
44		10	16		-	4 bits of Hor Image Size + 4 bits of Ver Image Size
45		00	0		0	Hor Border (pixels)
46	00	0		0	Vertical Border (Lines)	
47	1A	26			Refer to right table	

SPEC. NUMBER  
S

SPEC TITLE  
HT140WXB-101 Product Specification

PAGE  
33 OF 35



# PRODUCT GROUP

REV

ISSUE DATE

TFT LCD PRODUCT

0

2010.2.11

Address (HEX)	Function	Hex	Dec	crc	Input values.	Notes
48	Detailed timing/monitor descriptor #2	13	19		69.31	69.31MHz Main clock
49		1B	27			
4A		56	86		1366	Hor Active = 1366
4B		64	100		100	Hor Blanking = 100
4C		50	80		-	4 bits of Hor. Active + 4 bits of Hor. Blanking
4D		00	0		768	Ver Active = 768
4E		14	20		20	Ver Blanking = 20
4F		30	48		-	4 bits of Ver. Active + 4 bits of Ver. Blanking
50		30	48		48	Hor Sync Offset = 48
51		20	32		32	H Sync Pulse Width = 32
52		36	54		3	V sync Offset = 3 line
53		00	0		6	V Sync Pulse width : 6 line
54		35	53		309	Horizontal Image Size = 309 mm (Low 8 bits)
55		AD	173		173	Vertical Image Size = 173 mm (Low 8 bits)
56		10	16		-	4 bits of Hor Image Size + 4 bits of Ver Image Size
57		00	0		0	Hor Border (pixels)
58		00	0		0	Vertical Border (Lines)
59		1A	26			
5A		Detailed timing/monitor descriptor #3	00	0		
5B	00		0			
5C	00		0			
5D	FE		254			
5E	00		0			
5F	4B		75		K	D/PN: KFDV9
60	46		70		F	
61	44		68		D	
62	56		86		V	
63	39		57		9	
64	80		128			EDID: A00
65	48		72		H	BOE PN
66	54		84		T	
67	31		49		1	
68	34	52		4		
69	31	49		1		
6A	30	48		0		
6B	31	49		1		

SPEC. NUMBER  
S

SPEC TITLE  
HT140WXB-101 Product Specification

PAGE  
34 OF 35



# PRODUCT GROUP

REV

ISSUE DATE

TFT LCD PRODUCT

0

2010.2.11

Address (HEX)	Function	Hex	Dec	crc	Input values.	Notes
6C	Detailed timing/monitor descriptor #4	00	0			Product Name Tag (ASCII)
6D		00	0			
6E		00	0			
6F		00	0			
70		00	0			
71		00	0		00000000	
72		41	65		01000001	WLED & singal light bar & one light bar
73		01	1		00000001	Frame rate 40Hz~65Hz
74		94	148		10010100	Light Controller:PWM & Max. Luminance 200
75		01	1		00000001	Front Surface:Glossy & RGB v-stripe
76		00	0		00000000	no NTSC & no DBC
77		00	0		00000000	no Motion Blur & no Active Gamma
78		00	0		00000000	no Wireless Enhancement & no In-Cell Scanner
79		01	1		00000001	Single LVDS
7A		01	1		00000001	Built-In Self Test
7B		0A	10			
7C	20	32				
7D	20	32				
7E	Extension flag	00	0			
7F	Checksum	89	89	137	-	

SPEC. NUMBER  
S

SPEC TITLE  
HT140WXB-101 Product Specification

PAGE  
35 OF 35