



PROPRIETARY NOTE
 THIS SPECIFICATION IS THE PROPERTY OF BOE OT AND SHALL NOT BE REPRODUCED OR COPIED WITHOUT THE WRITTEN PERMISSION OF BOE OT AND MUST BE RETURNED TO BOE OT UPON ITS REQUEST

TITLE : HT141WXB-100
Preliminary Product Specification
Rev. P0

BEIJING BOE OPTOELECTRONICS TECHNOLOGY

SPEC. NUMBER S	PRODUCT GROUP TFT-LCD	REV. P0	ISSUE DATE 2008.04.18.	PAGE OF 31
-------------------	--------------------------	------------	---------------------------	---------------

 京东方 BOE	PRODUCT GROUP	REV	ISSUE DATE
	TFT LCD PRODUCT	P0	2008.04.18.

REVISION HISTORY

REV.	ECN NO.	DESCRIPTION OF CHANGES	DATE	PREPARED
P0	-	Initial Release	2008.04.18.	W. Kim

SPEC. NUMBER S	SPEC TITLE HT141WXB-100 Preliminary Product Specification	PAGE 2 OF 31
-------------------	--	-----------------

**PRODUCT GROUP**

REV

ISSUE DATE

TFT LCD PRODUCT

P0

2008.04.18.

Contents

No.	Items	Page
1.0	General Description	4
2.0	Absolute Maximum ratings	6
3.0	Electrical specifications.	7
4.0	Optical specifications.	9
5.0	Interface Connection	14
6.0	Signal Timing Specification	17
7.0	Signal Timing waveforms	17
8.0	Input Signals, Display Colors & Gray Scale of Colors	19
9.0	Power Sequence	20
10.0	Mechanical Characteristics	21
11.0	Reliability Test	22
12.0	Handling & Cautions.	22
13.0	Label	23
14.0	Packing information	25
15.0	Mechanical Outline Dimension	26
16.0	EDID Table	28

 SPEC. NUMBER
S

 SPEC TITLE
HT141WXB-100 Preliminary Product Specification

 PAGE
3 OF 31



PRODUCT GROUP

REV

ISSUE DATE

TFT LCD PRODUCT

P0

2008.04.18.

1.0 GENERAL DESCRIPTION

1.1 Introduction

HT141WXB-100 is a color active matrix TFT LCD module using amorphous silicon TFT's (Thin Film Transistors) as an active switching devices. This module has a 14.1 inch diagonally measured active area with WXGA resolutions (1280 horizontal by 800 vertical pixel array). Each pixel is divided into RED, GREEN, BLUE dots which are arranged in vertical Stripe and this module can display 262,144 colors. The TFT-LCD panel used for this module is a low reflection and higher color type. Therefore, this module is suitable for Notebook PC. The DC/AC inverter for back-light driving is not built in this model.

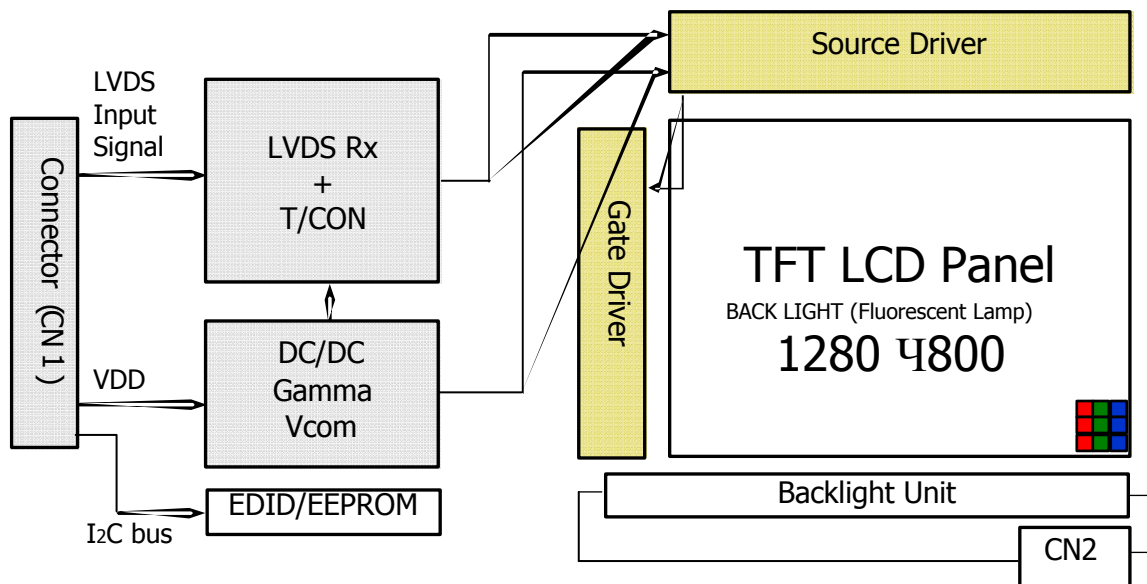

1.2 Features

- SPWG (Standard Panel Working Group) 14.1" W type WXGA(16:10) Form Factor
- Thin and light weight
- 3.3 V power supply
- 1 Channel LVDS Interface
- Single CCFL (Bottom side/Horizontal Direction)
- 262,144 colors
- Data enable signal mode
- Side Mounting Frame
- Green Product (RoHS product)
- On board EDID chip
- Low driving voltage and low power consumption

SPEC. NUMBER
S

SPEC TITLE
HT141WXB-100 Preliminary Product Specification

PAGE
4 OF 31



京东方
BOE

PRODUCT GROUP

REV

ISSUE DATE

TFT LCD PRODUCT

P0

2008.04.18.

1.3 Application

- Notebook PC (Wide type)

1.4 General Specification

The followings are general specifications at the model HT141WXB-100. (listed in Table 1.)

<Table 1. General Specifications>

Parameter	Specification	Unit	Remarks
Active area	303.36 (H) Ԅ189.60 (V) (14.1" diagonal)	mm	
Number of pixels	1280 (H) Ԅ800 (V)	pixels	
Pixel pitch	0.237 (H) Ԅ0.237 (V)	mm	
Pixel arrangement	RGB Vertical stripe		
Display colors	262,144	colors	
Display mode	Normally White		
Dimensional outline	319.5±0.5 (H) Ԅ205.5±0.5 (V) Ԅ5.5 (D:max)	mm	
Weight	400 (typ)	g	
Surface treatment	Glare (Clear Black) / Hard coating 3H		
Back-light	Bottom edge side, 1-CCFL type		Note 1
Power consumption	P _D : 1.1	W	
	P _{BL} : 4.1	W	
	P _{total} : 5.2	W	

Notes : 1. CCFL (Cold Cathode Fluorescent Lamp)

SPEC. NUMBER
S

SPEC TITLE
HT141WXB-100 Preliminary Product Specification

PAGE
5 OF 31



PRODUCT GROUP

REV

ISSUE DATE

TFT LCD PRODUCT

P0

2008.04.18.

2.0 ABSOLUTE MAXIMUM RATINGS

The followings are maximum values which, if exceed, may cause faulty operation or damage to the unit. The operational and non-operational maximum voltage and current values are listed in Table 2.

< Table 2. Absolute Maximum Ratings >

Ta=25+/-2°C

Parameter	Symbol	Min.	Max.	Unit	Remarks
Power Supply Voltage	V _{DD}	-0.3	4.0	V	
Logic Supply Voltage	V _{IN}	-0.3	V _{DD} +0.3	V	
Lamp Current	I _L	2.0	7.0	mArms	Note 1
Lamp frequency	F _L	40	80	kHz	
Operating Temperature	T _{OP}	0	+50	°C	Note 2
Storage Temperature	T _{SP}	-20	+70	°C	

- Notes : 1. Permanent damage to the device may occur if maximum values are exceeded functional operation should be restricted to the condition described under normal operating conditions.
2. Temperature and relative humidity range are shown in the figure below.
 95 % RH Max. (40°C ≥ Ta)
 Maximum wet - bulb temperature at 39 oC or less. (Ta > 40 oC) No condensation.

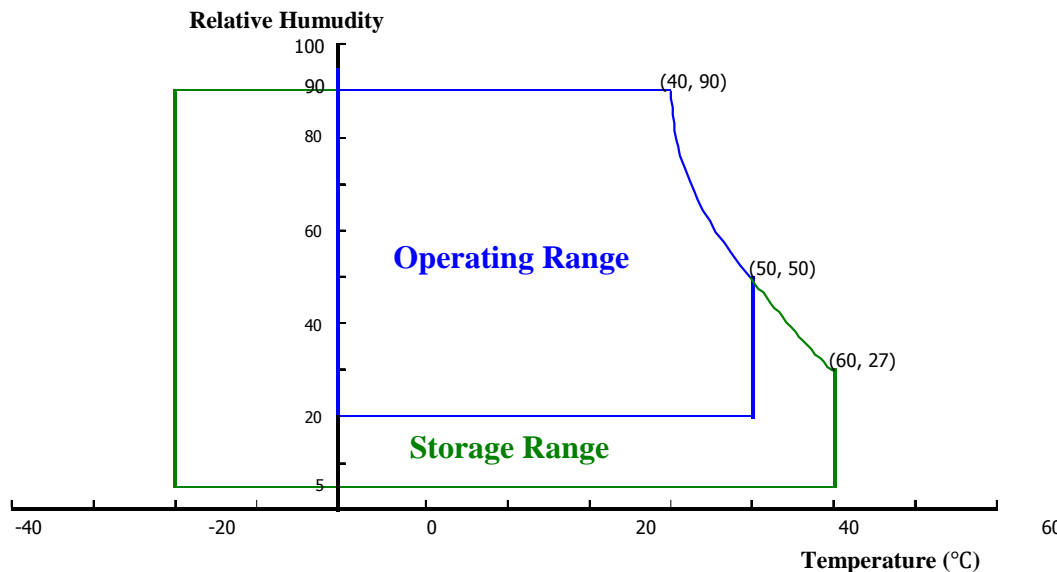

SPEC. NUMBER
S

SPEC TITLE
HT141WXB-100 Preliminary Product Specification

PAGE
6 OF 31

**PRODUCT GROUP**

REV

ISSUE DATE

TFT LCD PRODUCT

P0

2008.04.18.

3.0 ELECTRICAL SPECIFICATIONS**3.1 Electrical Specifications**

< Table 3. Electrical specifications >

 $I_{BL} = 6.0\text{mA}$

Parameter		Min.	Typ.	Max.	Unit	Remarks
Power Supply Voltage	V_{DD}	3.0	3.3	3.6	V	Note 1
Permissible Input Ripple Voltage	V_{RF}	-	-	100	mV	At $V_{DD} = 3.3\text{V}$
Power Supply Current	I_{DD}	-	330	400	mA	Note 1
High Level Differential Input Signal Voltage	V_{IH}	-	-	100	mV	
Low Level Differential Input Signal Voltage	V_{IL}	-	-	100	mV	
Back-light Lamp Voltage	V_{BL}	-	657	-	V_{rms}	Note 2
Back-light Lamp Current	I_{BL}	2.0	6.0	7.0	mA	
Back-light Lamp operating Frequency	F_L	40	60	80	KHz	One Lamp Note 3
Lamp Start Voltage		-	680		V_{rms}	At $T_a = 25^\circ\text{C}$ Note 4
		-	-		V_{rms}	At $T_a = 0^\circ\text{C}$ Note 4
Lamp Life		10000	15000	-	Hrs	Note 5
Power Consumption	P_D	-	1.1	1.3	W	Note 1
	P_{BL}	-	4.1	4.3	W	Note 6
	P_{total}	-	5.2	5.6	W	

SPEC. NUMBER
SSPEC TITLE
HT141WXB-100 Preliminary Product SpecificationPAGE
7 OF 31

 京东方 BOE	PRODUCT GROUP	REV	ISSUE DATE
	TFT LCD PRODUCT	P0	2008.04.18.

- Notes :
- The supply voltage is measured and specified at the interface connector of LCM.
The current draw and power consumption specified is for 3.3V at 25°C.
 - Typ : Window XP pattern
 - Max : Vertical 2 line skip pattern
 - Reference value, which is measured with Samsung Electric SIC-180 Inverter.
(VBL Min is value at IBL Min and VBL Max is value at IBL Max)
 - The lamp frequency should be selected as different as possible from the horizontal synchronous frequency and its harmonics to avoid interference which may cause line flow on the display.
 - For starting the backlight unit, the output voltage of DC/AC's transformer should be larger than the minimum lamp starting voltage.
(1,240 Vrms at 25 °C & 1,490 Vrms at 0 °C)
If an inverter has shutdown function it should keep its output for more than 1 second even if the lamp connector open. Otherwise the lamps may not to be turned on.
 - End of Life shall be determined by the time when any of the following is satisfied under continuous lighting at 25°C and IBL = 6.0[mA] Max Only.
 - Intensity drops to 50% of the Initial Value.
 - Calculated value for reference (VBL \neq IBL)

4.0 OPTICAL SPECIFICATION

4.1 Overview

The test of Optical specifications shall be measured in a dark room (ambient luminance \leq 1 lux and temperature = 25 \pm 2°C) with the equipment of Luminance meter system (Goniometer system and TOPCONE BM-5) and test unit shall be located at an approximate distance 50cm from the LCD surface at a viewing angle of θ and Φ equal to 0°. We refer to $\theta=0$ ($=\theta_3$) as the 3 o'clock direction (the "right"), $\theta=90$ ($=\theta_{12}$) as the 12 o'clock direction ("upward"), $\theta=180$ ($=\theta_9$) as the 9 o'clock direction ("left") and $\theta=270$ ($=\theta_6$) as the 6 o'clock direction ("bottom"). While scanning θ and/or Φ , the center of the measuring spot on the Display surface shall stay fixed. The backlight should be operating for 30 minutes prior to measurement... VDD shall be 3.3 \pm 0.3V at 25°C. Optimum viewing angle direction is 6 o'clock.

SPEC. NUMBER S	SPEC TITLE HT141WXB-100 Preliminary Product Specification	PAGE 8 OF 31
-------------------	--	-----------------

**PRODUCT GROUP**

REV

ISSUE DATE

TFT LCD PRODUCT

P0

2008.04.18.

4.2 Optical Specifications

<Table 4. Optical Specifications>

Parameter		Symbol	Condition	Min.	Typ.	Max.	Unit	Remark
Viewing Angle range	Horizontal	Θ_3	CR > 10	45	45	-	Deg.	Note 1
		Θ_9		45	45	-	Deg.	
	Vertical	Θ_{12}		15	25	-	Deg.	
		Θ_6		40	40	-	Deg.	
Luminance Contrast ratio		CR	$\Theta = 0^\circ$	300	500			Note 2
Luminance of White	5 Points	Y_w	$\Theta = 0^\circ$ IBL = 6mA	200	230		cd/m ²	Note 3
White Luminance uniformity	5 Points	ΔY_5		80	85			Note 4
	13 Points	ΔY_{13}		65	75			
White Chromaticity		x_w	$\Theta = 0^\circ$	0.283	0.313	0.343		Note 5
		y_w		0.299	0.329	0.359		
Reproduction of color	Red	x_R	$\Theta = 0^\circ$		TBD			
		y_R			TBD			
	Green	x_G			TBD			
		y_G			TBD			
	Blue	x_B			TBD			
		y_B			TBD			
Response Time (Rising + Falling)		T_{RT}	Ta= 25° C $\Theta = 0^\circ$	-	8	16	ms	Note 6
Cross Talk		CT	$\Theta = 0^\circ$	-	-	2.0	%	Note 7

SPEC. NUMBER

S

SPEC TITLE

HT141WXB-100 Preliminary Product Specification

PAGE

9 OF 31

 京东方 BOE	PRODUCT GROUP	REV	ISSUE DATE
	TFT LCD PRODUCT	P0	2008.04.18.

Notes : 1. Viewing angle is the angle at which the contrast ratio is greater than 10. The viewing angles are determined for the horizontal or 3, 9 o'clock direction and the vertical or 6, 12 o'clock direction with respect to the optical axis which is normal to the LCD surface (see FIGURE 1).

2. Contrast measurements shall be made at viewing angle of $\Theta = 0$ and at the center of the LCD surface. Luminance shall be measured with all pixels in the view field set first to white, then to the dark (black) state .
(see FIGURE 1) Luminance Contrast Ratio (CR) is defined mathematically.

$$CR = \frac{\text{Luminance when displaying a white raster}}{\text{Luminance when displaying a black raster}}$$

3. Center Luminance of white is defined as luminance values of 5 point average across the LCD surface. Luminance shall be measured with all pixels in the view field set first to white. This measurement shall be taken at the locations shown in FIGURE 2 for a total of the measurements per display.
4. The White luminance uniformity on LCD surface is then expressed as : $\Delta Y = \frac{\text{Minimum Luminance of 5(or 13) points}}{\text{Maximum Luminance of 5(or 13) points}}$ (see FIGURE 2 and FIGURE 3).
5. The color chromaticity coordinates specified in Table 4 shall be calculated from the spectral data measured with all pixels first in red, green, blue and white. Measurements shall be made at the center of the panel.
6. The electro-optical response time measurements shall be made as FIGURE 4 by switching the "data" input signal ON and OFF. The times needed for the luminance to change from 10% to 90% is T_r , and 90% to 10% is T_d .
7. Cross-Talk of one area of the LCD surface by another shall be measured by comparing the luminance (YA) of a 25mm diameter area, with all display pixels set to a gray level, to the luminance (YB) of that same area when any adjacent area is driven dark. (See FIGURE 5).

SPEC. NUMBER S	SPEC TITLE HT141WXB-100 Preliminary Product Specification	PAGE 10 OF 31
-------------------	--	------------------



PRODUCT GROUP

REV

ISSUE DATE

TFT LCD PRODUCT

P0

2008.04.18.

4.3 Optical measurements

Figure 1. Measurement Set Up

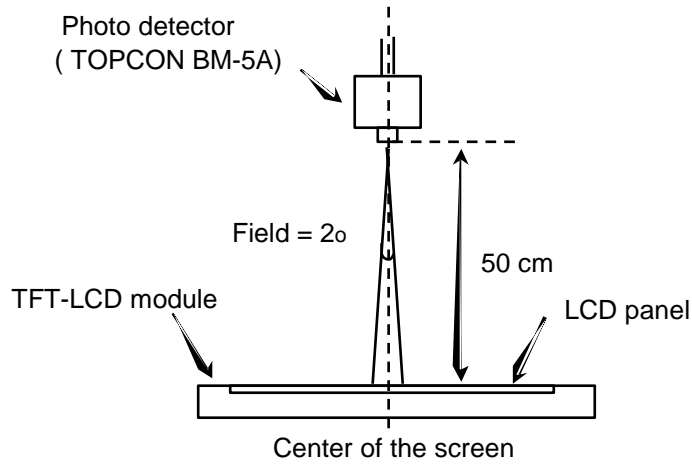

Optical characteristics measurement setup

Figure 2. White Luminance and Uniformity Measurement Locations (5 points)

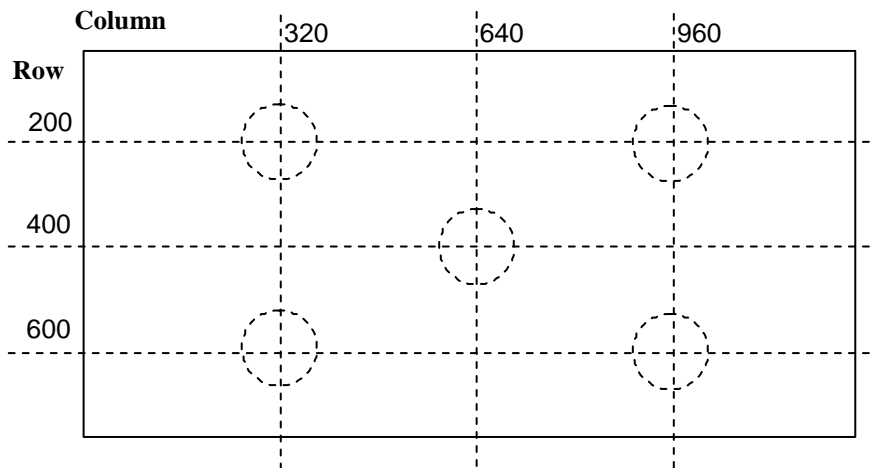

Center Luminance of white is defined as luminance values of center 5 points across the LCD surface. Luminance shall be measured with all pixels in the view field set first to white. This measurement shall be taken at the locations shown in FIGURE 2 for a total of the measurements per display.

SPEC. NUMBER
S

SPEC TITLE
HT141WXB-100 Preliminary Product Specification

PAGE
11 OF 31



京东方
BOE

PRODUCT GROUP

TFT LCD PRODUCT

REV

P0

ISSUE DATE

2008.04.18.

Figure 3. Uniformity Measurement Locations (13 points)

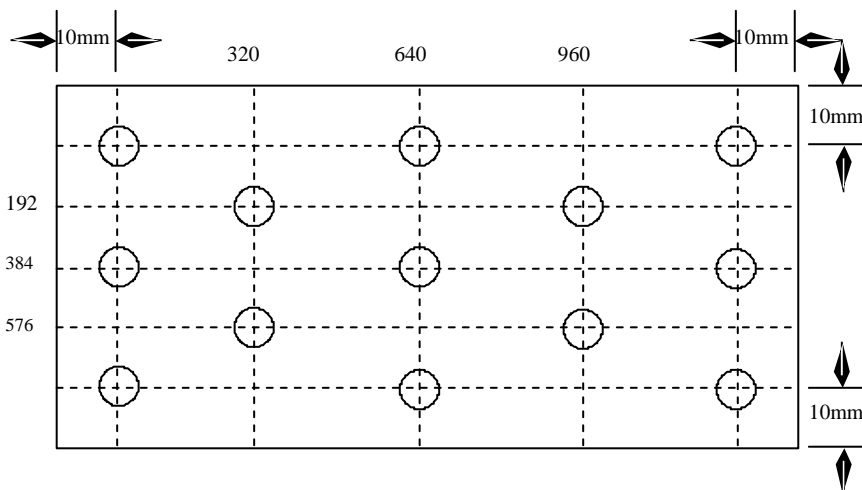

The White luminance uniformity on LCD surface is then expressed as : $\Delta Y5 = \text{Minimum Luminance of five points} / \text{Maximum Luminance of five points}$ (see FIGURE 2) , $\Delta Y13 = \text{Minimum Luminance of 13 points} / \text{Maximum Luminance of 13 points}$ (see FIGURE 3).

Figure 4. Response Time Testing

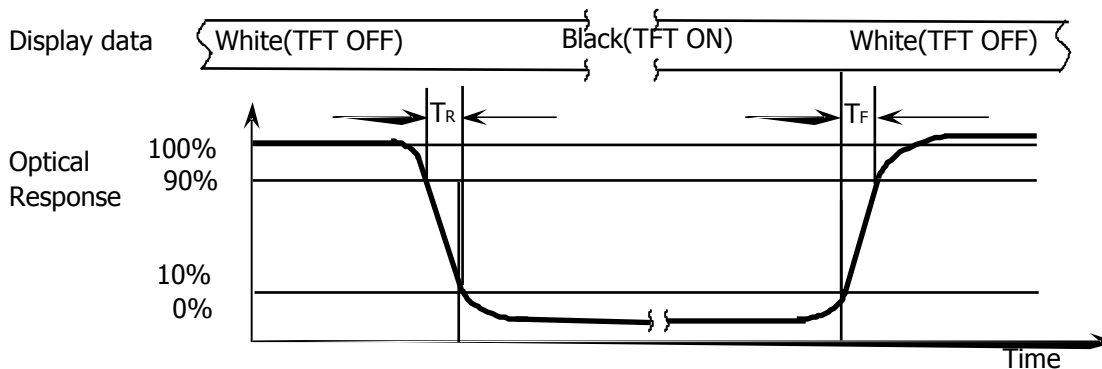

The electro-optical response time measurements shall be made as shown in FIGURE 4 by switching the "data" input signal ON and OFF. The times needed for the luminance to change from 10% to 90% is T_d and 90% to 10% is T_r .

SPEC. NUMBER
S

SPEC TITLE
HT141WXB-100 Preliminary Product Specification

PAGE
12 OF 31



PRODUCT GROUP

REV

ISSUE DATE

TFT LCD PRODUCT

P0

2008.04.18.

Figure 5. Cross Modulation Test Description

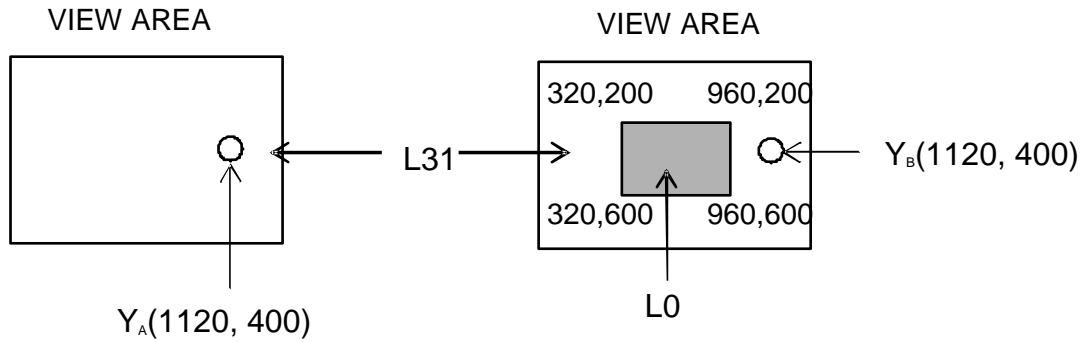

$$\text{Cross-Talk (\%)} = \left| \frac{Y_B - Y_A}{Y_B} \right| \times 100$$

Where:

Y_A = Initial luminance of measured area (cd/m²)

Y_B = Subsequent luminance of measured area (cd/m²)

The location measured will be exactly the same in both patterns

Cross-Talk of one area of the LCD surface by another shall be measured by comparing the luminance (Y_A) of a 25mm diameter area, with all display pixels set to a gray level, to the luminance (Y_B) of that same area when any adjacent area is driven dark (Refer to FIGURE 5).

SPEC. NUMBER
S

SPEC TITLE
HT141WXB-100 Preliminary Product Specification

PAGE
13 OF 31



PRODUCT GROUP

REV

ISSUE DATE

TFT LCD PRODUCT

P0

2008.04.18.

5.0 INTERFACE CONNECTION.

5.1 Electrical Interface Connection

The electronics interface connector is a model IS100-L30R-C15 manufactured by UJU or equivalent. The mating connector part number is HS100-C30N-N15 or equivalent. The connector interface pin assignments are listed in Table 5.

<Table 5. Pin Assignments for the Interface Connector>

Terminal	Symbol	Functions
1	GND	Ground
2	VDD	Power Supply: +3.3V
3	VDD	Power Supply: +3.3V
4	VEDID	EDID +3.3V
5	Reserved	Reserved
6	Clk EDID	EDID Clk
7	Data EDID	EDID Data
8	RxIN0-	Transmission Data of 0 Negative -
9	RxIN0+	Transmission Data of 0 Positive +
10	GND	Ground
11	RxIN1-	Transmission Data of 0 Negative -
12	RxIN1+	Transmission Data of 0 Positive +
13	GND	Ground
14	RxIN2-	Transmission Data of 0 Negative -
15	RxIN2+	Transmission Data of 0 Positive +
16	GND	Ground
17	RxCLKIN-	Sampling Clock of Negative -
18	RxCLKIN+	Sampling Clock of Positive +
19	GND	Ground
20	NC	No Connection
21	NC	No Connection
22	GND	Ground
23	NC	No Connection
24	NC	No Connection
25	GND	Ground
26	NC	No Connection
27	NC	No Connection
28	GND	Ground
29	NC	No Connection
30	NC	No Connection

SPEC. NUMBER
S

SPEC TITLE
HT141WXB-100 Preliminary Product Specification

PAGE
14 OF 31



PRODUCT GROUP

REV

ISSUE DATE

TFT LCD PRODUCT

P0

2008.04.18.

5-2. LVDS Interface

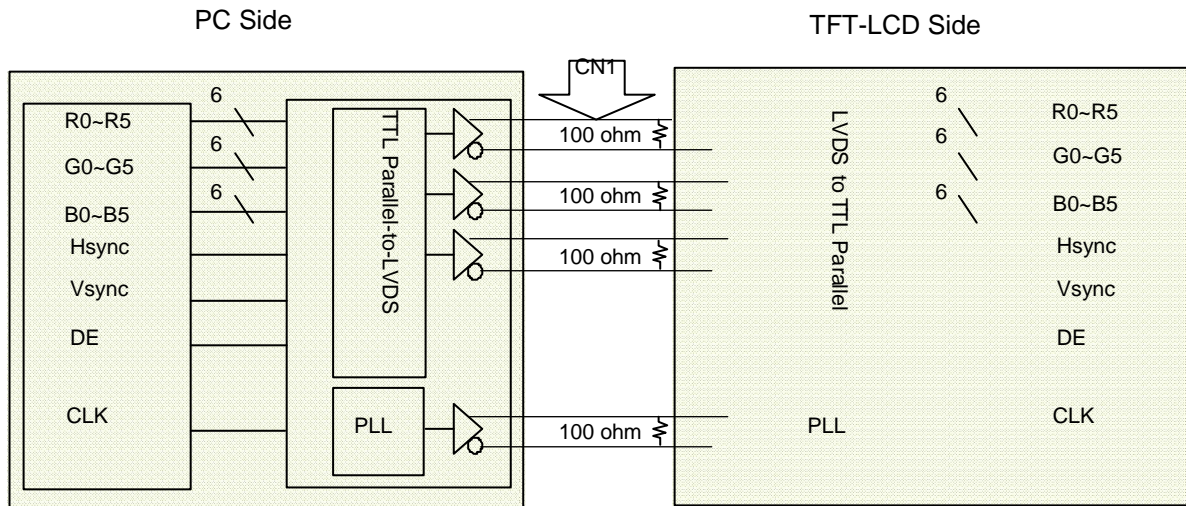

Note. Transmitter : Thine THC63LVDM63A or equivalent. Transmitter is not contained in Module.

5.3.LVDS Input signal

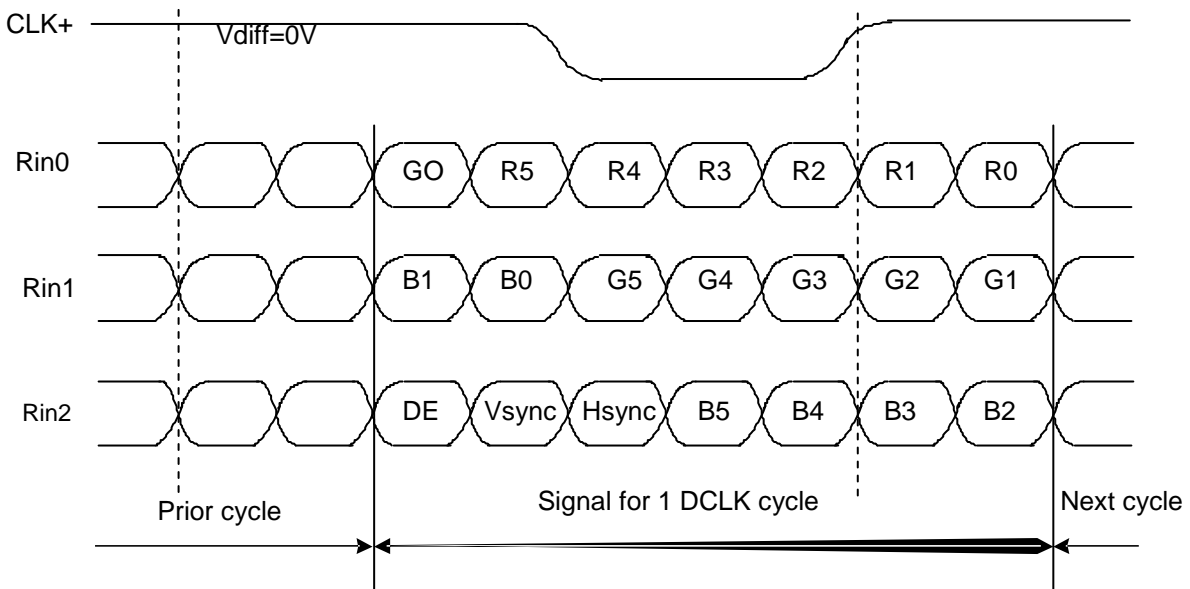

Note. Pin connection in case of using Thine THC63LVDM63A

SPEC. NUMBER
S

SPEC TITLE
HT141WXB-100 Preliminary Product Specification

PAGE
15 OF 31



京东方
BOE

PRODUCT GROUP

REV

ISSUE DATE

TFT LCD PRODUCT

P0

2008.04.18.

<Table 6. Pin connection in case of using Thine THC63LVDM63A>

Input signal	Transmitter	Input signal	Transmitter
DCLK	CLK IN(26)	G4	TB3(10)
R0	TA0(44)	G5	TB4(12)
R1	TA1(45)	B0	TB5(13)
R2	TA2(47)	B1	TB6(15)
R3	TA3(48)	B2	TC0(16)
R4	TA4(1)	B3	TC1(18)
R5	TA5(3)	B4	TC2(19)
G0	TA6(4)	B5	TC3(20)
G1	TB0(6)	Hsync	TC4(22)
G2	TB1(7)	Vsync	TC5(23)
G3	TB2(9)	DE	TC6(25)

5.4.Back-light Interface

The Back-light interface connector is a model BHSR-02VS-1 manufactured by JST or equivalent. The connector interface pin assignments are listed in Table 7.

<Table 7. Back-light Electrical Interface>

Terminal No.	Symbol	Function	Color
1	VL	CCFL Power Supply (High Voltage)	Pink
2	GL	CCFL Power Supply (GND Side)	Black

SPEC. NUMBER
S

SPEC TITLE
HT141WXB-100 Preliminary Product Specification

PAGE
16 OF 31



PRODUCT GROUP

REV

ISSUE DATE

TFT LCD PRODUCT

P0

2008.04.18.

6.0. SIGNAL TIMING SPECIFICATION

The specification of the signal timing parameters are listed in Table 8.

<Table 8. Signal Timing Specification.>

Item	Symbols	Min	Typ	Max	Unit
Frame Period	T1	804	823	-	Lines
Vertical Display Period	T2	-	800	-	Lines
One line Scanning Period	T3	1350	1440	-	Clocks
Horizontal Display Period	T4	-	1280	-	Clocks
Clock Frequency	1/T5	-	71.11	-	MHz

7.0 SIGNAL TIMING WAVEFORMS

7.1 Timing wave forms of interface signal

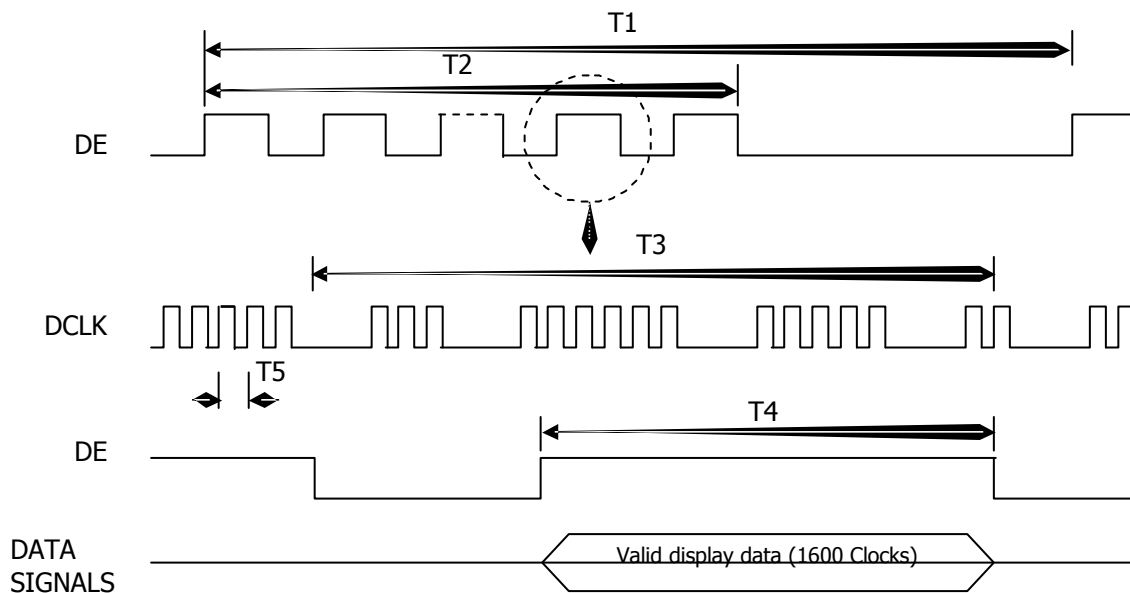

SPEC. NUMBER
S

SPEC TITLE
HT141WXB-100 Preliminary Product Specification

PAGE
17 OF 31



PRODUCT GROUP

REV

ISSUE DATE

TFT LCD PRODUCT

P0

2008.04.18.

7.2 LVDS Rx Interface Timing Parameter

The specification of the LVDS Rx interface timing parameter is listed in Table 9.

<Table 9. LVDS Rx Interface Timing Specification>

Item	Symbol	Min	Typ	Max	Unit	Remark
PLL Set	tRPLL	12.50	14.06	25.00	msec	
Input Data 0	tRIP0	-0.4	0.0	+0.4	nsec	
Input Data 1	tRIP1	tRICP/7-0.4	tRICP/7	tRICP/7+0.4	nsec	
Input Data 2	tRIP2	2 ¼tRICP/7-0.4	2 ¼tRICP/7	2 ¼tRICP/7+0.4	nsec	
Input Data 3	tRIP3	3 ¼tRICP/7-0.4	3 ¼tRICP/7	3 ¼tRICP/7+0.4	nsec	
Input Data 4	tRIP4	4 ¼tRICP/7-0.4	4 ¼tRICP/7	4 ¼tRICP/7+0.4	nsec	
Input Data 5	tRIP5	5 ¼tRICP/7-0.4	5 ¼tRICP/7	5 ¼tRICP/7+0.4	nsec	
Input Data 6	tRIP6	6 ¼tRICP/7-0.4	6 ¼tRICP/7	6 ¼tRICP/7+0.4	nsec	

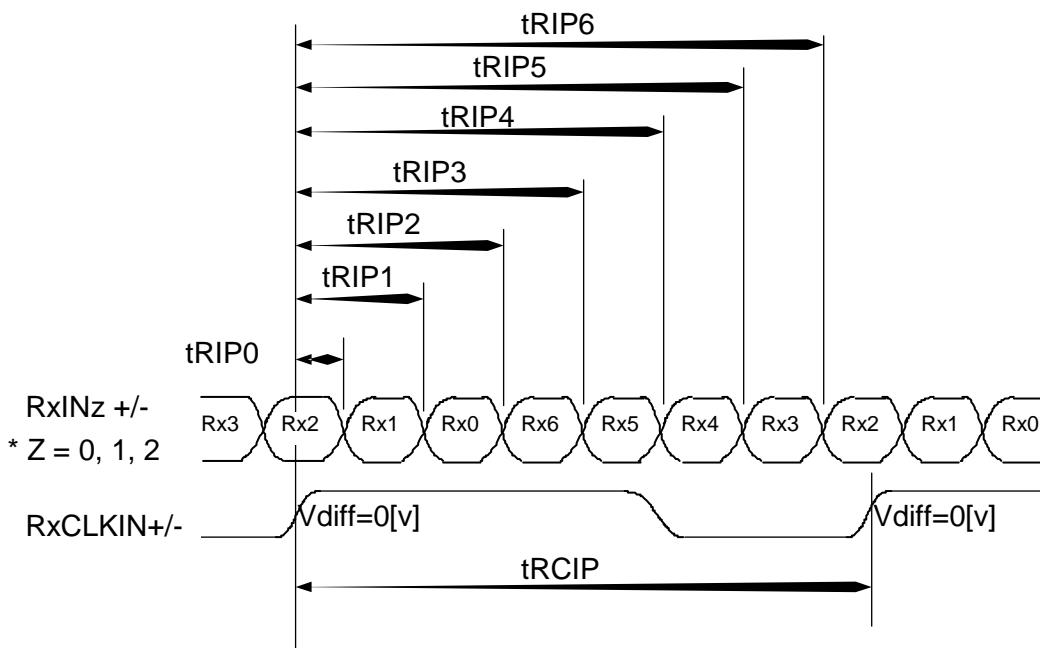

SPEC. NUMBER
S

SPEC TITLE
HT141WXB-100 Preliminary Product Specification

PAGE
18 OF 31



京东方
BOE

PRODUCT GROUP

REV

ISSUE DATE

TFT LCD PRODUCT

P0

2008.04.18.

8.0 INPUT SIGNALS, BASIC DISPLAY COLORS & GRAY SCALE OF COLORS

Each color is displayed in sixty-four gray scales from a 6 bit data signal input. A total of 262,144 colors are derived from the resultant 18 bit data. Table 10. shows the input signals, basic display colors and gray scale for each color.

<Table 10. Input signals, Basic display colors and Gray scale for each color.>

	Colors & Gray scale	Data signal																
		R0	R1	R2	R3	R4	G0	G1	G2	G3	G4	G5	B0	B1	B2	B3	B4	B5
Basic colors	R5																	
	Black	0	0	0	0	0	0	0	0	0	0	0	0	0	0	0	0	0
	Blue	0	0	0	0	0	0	0	0	0	0	0	1	1	1	1	1	1
	Green	0	0	0	0	0	0	1	1	1	1	1	1	0	0	0	0	0
	Light Blue	0	0	0	0	0	0	1	1	1	1	1	1	1	1	1	1	1
	Red	1	1	1	1	1	1	0	0	0	0	0	0	0	0	0	0	0
Gray scale of Red	Purple	1	1	1	1	1	1	0	0	0	0	0	0	0	0	0	0	0
	Yellow	1	1	1	1	1	1	1	1	1	1	1	0	0	0	0	0	0
	White	1	1	1	1	1	1	1	1	1	1	1	1	1	1	1	1	1
	Black	0	0	0	0	0	0	0	0	0	0	0	0	0	0	0	0	0
	Δ	1	0	0	0	0	0	0	0	0	0	0	0	0	0	0	0	0
	Darker	0	1	0	0	0	0	0	0	0	0	0	0	0	0	0	0	0
Gray scale of Green	Δ																	
	▽																	
	Brighter	1	0	1	1	1	1	0	0	0	0	0	0	0	0	0	0	0
	▽	0	1	1	1	1	1	0	0	0	0	0	0	0	0	0	0	0
	Red	1	1	1	1	1	1	0	0	0	0	0	0	0	0	0	0	0
	Black	0	0	0	0	0	0	0	0	0	0	0	0	0	0	0	0	0
Gray scale of Blue	Δ	0	0	0	0	0	0	1	0	0	0	0	0	0	0	0	0	0
	Darker	0	0	0	0	0	0	0	1	0	0	0	0	0	0	0	0	0
	Δ																	
	▽																	
	Brighter	0	0	0	0	0	0	1	0	1	1	1	1	0	0	0	0	0
	▽	0	0	0	0	0	0	0	1	1	1	1	1	0	0	0	0	0
Gray scale of White & Black	Green	0	0	0	0	0	0	1	1	1	1	1	1	0	0	0	0	0
	Black	0	0	0	0	0	0	0	0	0	0	0	0	0	0	0	0	0
	Δ	0	0	0	0	0	0	0	0	0	0	0	0	1	0	0	0	0
	Darker	0	0	0	0	0	0	0	0	0	0	0	0	0	1	0	0	0
	Δ																	
	▽																	
Gray scale of White & Black	Brighter	0	0	0	0	0	0	0	0	0	0	0	1	0	1	1	1	1
	▽	0	0	0	0	0	0	0	0	0	0	0	0	1	1	1	1	1
	Blue	0	0	0	0	0	0	0	0	0	0	0	1	1	1	1	1	1
	Black	0	0	0	0	0	0	0	0	0	0	0	0	0	0	0	0	0
	Δ	1	0	0	0	0	0	1	0	0	0	0	0	1	0	0	0	0
	Darker	0	1	0	0	0	0	0	1	0	0	0	0	0	1	0	0	0
Gray scale of White & Black	Δ																	
	▽																	
	Brighter	1	0	1	1	1	1	1	0	1	1	1	1	1	0	1	1	1
	▽	0	1	1	1	1	1	0	1	1	1	1	1	0	1	1	1	1
	White	1	1	1	1	1	1	1	1	1	1	1	1	1	1	1	1	1
	Black	0	0	0	0	0	0	0	0	0	0	0	0	0	0	0	0	0

SPEC. NUMBER

SPEC TITLE

PAGE

S

HT141WXB-100 Preliminary Product Specification

19 OF 31



京东方
BOE

PRODUCT GROUP

REV

ISSUE DATE

TFT LCD PRODUCT

P0

2008.04.18.

9.0 POWER SEQUENCE

To prevent a latch-up or DC operation of the LCD module, the power on/off sequence shall be as shown in below

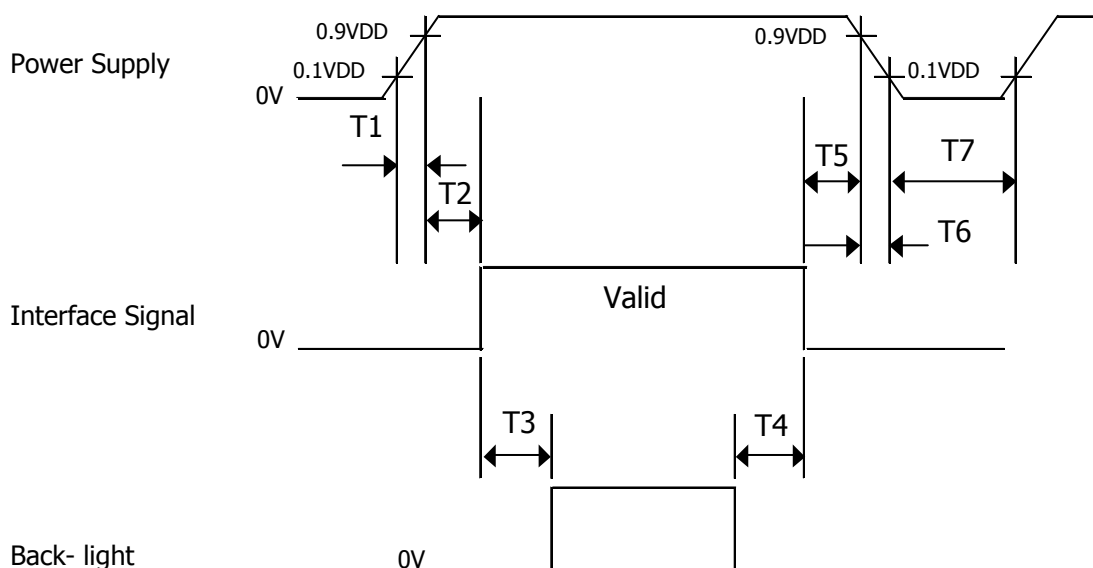

- $T1 \leq 10 \text{ ms}$
- $0 \leq T2 \leq 50 \text{ ms}$
- $200 \text{ ms} \leq T3$
- $200 \text{ ms} \leq T4$
- $0 \leq T5 \leq 50 \text{ ms}$
- $0 \leq T6 \leq 10 \text{ ms}$
- $200 \text{ ms} \leq T7$

Notes : 1. When the power supply VDD is 0V, Keep the level of input signals on the low or keep high impedance.

2. Do not keep the interface signal high impedance when power is on.
Back Light must be turn on after power for logic and interface signal are valid.

SPEC. NUMBER
S

SPEC TITLE
HT141WXB-100 Preliminary Product Specification

PAGE
20 OF 31

 京东方 BOE	PRODUCT GROUP	REV	ISSUE DATE
	TFT LCD PRODUCT	P0	2008.04.18.

10.0 MECHANICAL CHARACTERISTICS

10.1 Dimensional Requirements

FIGURE 6 shows mechanical outlines for the model HT141WXB-100.
Other parameters are shown in Table 11.

<Table 11. Dimensional Parameters>

Parameter	Specification	Unit
Active Area	303.36 (H) 4189.60 (V)	
Number of pixels	1280 (H) X 800 (V) (1 pixel = R + G + B dots)	
Pixel pitch	0.237 (H) X 0.237 (V)	
Pixel arrangement	RGB Vertical stripe	
Display colors	262,144	
Display mode	Normally white	
Dimensional outline	319.5±0.54205.5±0.545.5 max	mm
Weight	400 (typ)	gram
Back-light	Connector : BHSR-02VS-1	
	CCFL, Horizontal-lamp type	
	Length : 70.0±5.0	mm

10.2 Mounting

See FIGURE 6.

10.3 Glare and Polarizer Hardness.

The surface of the LCD has an glare coating to maximize readability and hard coating to reduce scratching.

10.4 Light Leakage

There shall not be visible light from the back-lighting system around the edges of the screen as seen from a distance 50cm from the screen with an overhead light level of 350lux.

SPEC. NUMBER S	SPEC TITLE HT141WXB-100 Preliminary Product Specification	PAGE 21 OF 31
-------------------	--	------------------

 京东方 BOE	PRODUCT GROUP	REV	ISSUE DATE
	TFT LCD PRODUCT	P0	2008.04.18.

11.0 RELIABILITY TEST

The Reliability test items and its conditions are shown in below.

<Table 12. Reliability test>

No	Test Items	Conditions
1	High temperature storage test	Ta = 60 °C, 240 hrs
2	Low temperature storage test	Ta = -20 °C, 240 hrs
3	High temperature & high humidity operation test	Ta = 50 °C, 80%RH, 240 hrs
4	High temperature operation test	Ta = 50 °C, 240 hrs
5	Low temperature operation test	Ta = 0 °C, 240 hrs
6	Thermal shock	Ta = -20 °C ↔ 60 °C (0.5 hr), 100 cycle
7	Vibration test (non-operating)	1.5G, 1~500Hz Random ±X,±Y,±Z / Sweep rate : 0.5hour
8	Shock test (non-operating)	220G, Half Sine Wave 2msec ±X,±Y,±Z Once for each direction
9	Electro-static discharge test (non-operating)	Air : 150 pF, 330Ω, 15 KV Contact : 150 pF, 330Ω, 8 KV

12.0 HANDLING & CAUTIONS

(1) Cautions when taking out the module

- Pick the pouch only, when taking out module from a shipping package.

(2) Cautions for handling the module

- As the electrostatic discharges may break the LCD module, handle the LCD module with care. Peel a protection sheet off from the LCD panel surface as slowly as possible.
- As the LCD panel and back - light element are made from fragile glass material, impulse and pressure to the LCD module should be avoided.
- As the surface of the polarizer is very soft and easily scratched, use a soft dry cloth without chemicals for cleaning.
- Do not pull the interface connector in or out while the LCD module is operating.
- Put the module display side down on a flat horizontal plane.
- Handle connectors and cables with care.

(3) Cautions for the operation

- When the module is operating, do not lose CLK, ENAB signals. If any one of these signals is lost, the LCD panel would be damaged.
- Obey the supply voltage sequence. If wrong sequence is applied, the module would be damaged.

SPEC. NUMBER S	SPEC TITLE HT141WXB-100 Preliminary Product Specification	PAGE 22 OF 31
-------------------	--	------------------

 京东方 BOE	PRODUCT GROUP	REV	ISSUE DATE
	TFT LCD PRODUCT	P0	2008.04.18.

- (4) Cautions for the atmosphere
- Dew drop atmosphere should be avoided.
 - Do not store and/or operate the LCD module in a high temperature and/or humidity atmosphere. Storage in an electro-conductive polymer packing pouch and under relatively low temperature atmosphere is recommended.
- (5) Cautions for the module characteristics
- Do not apply fixed pattern data signal to the LCD module at product aging.
 - Applying fixed pattern for a long time may cause image sticking.
- (6) Other cautions
- Do not disassemble and/or re-assemble LCD module.
 - Do not re-adjust variable resistor or switch etc.
 - When returning the module for repair or etc., Please pack the module not to be broken. We recommend to use the original shipping packages.

13.0 LABEL

(1) Product label



1 2 3 4 5 6 7

X	X	X	X	X	1	0	0	X	X	X	X	X	X	X
---	---	---	---	---	---	---	---	---	---	---	---	---	---	---

Type designation	No 5. Month (1, 2, 3, ..., 9, X, Y, Z)
No 1. Control Number	No 6. Product Identification (FG)
No 2. Rank / Grade	No 7. Serial Number
No 3. Line classification (BOE HYDIS:H, BOE OT:A/BC)	
No 4. Year (05 : 2005, 06: 2006, ...)	

SPEC. NUMBER S	SPEC TITLE HT141WXB-100 Preliminary Product Specification	PAGE 23 OF 31
-------------------	--	------------------

 京东方 BOE	PRODUCT GROUP	REV	ISSUE DATE
	TFT LCD PRODUCT	P0	2008.04.18.

(2) High voltage caution label

	HIGH VOLTAGE CAUTION	COLD CATHODE FLUORESCENT LAMP IN LCD PANEL CONTAINS A SMALL AMOUNT OF MERCURY. PLEASE FOLLOW LOCAL OR- DINANCES OR REGULATIONS FOR DISPOSAL.
	RISK OF ELECTRIC SHOCK. DISCONNECT THE ELECTRIC POWER BEFORE SERVICING	

(3) Box label

Label Size: 110 mm (L) × 56 mm (W)

Contents

Model: HT141WXB-100

Q`ty: Module Q`ty in one box

Serial No.: Box Serial No. See next figure for detail description.

Date: Packing Date

FG Code: FG Code of Product



00	0	0	00	0	0000	000000
Type	Grade	Line	Year	Month	FG-Code	Serial No

SPEC. NUMBER S	SPEC TITLE HT141WXB-100 Preliminary Product Specification	PAGE 24 OF 31
-------------------	--	------------------



PRODUCT GROUP

REV

ISSUE DATE

TFT LCD PRODUCT

P0

2008.04.18.

14.0 PACKING INFORMATION

14.1 Packing order

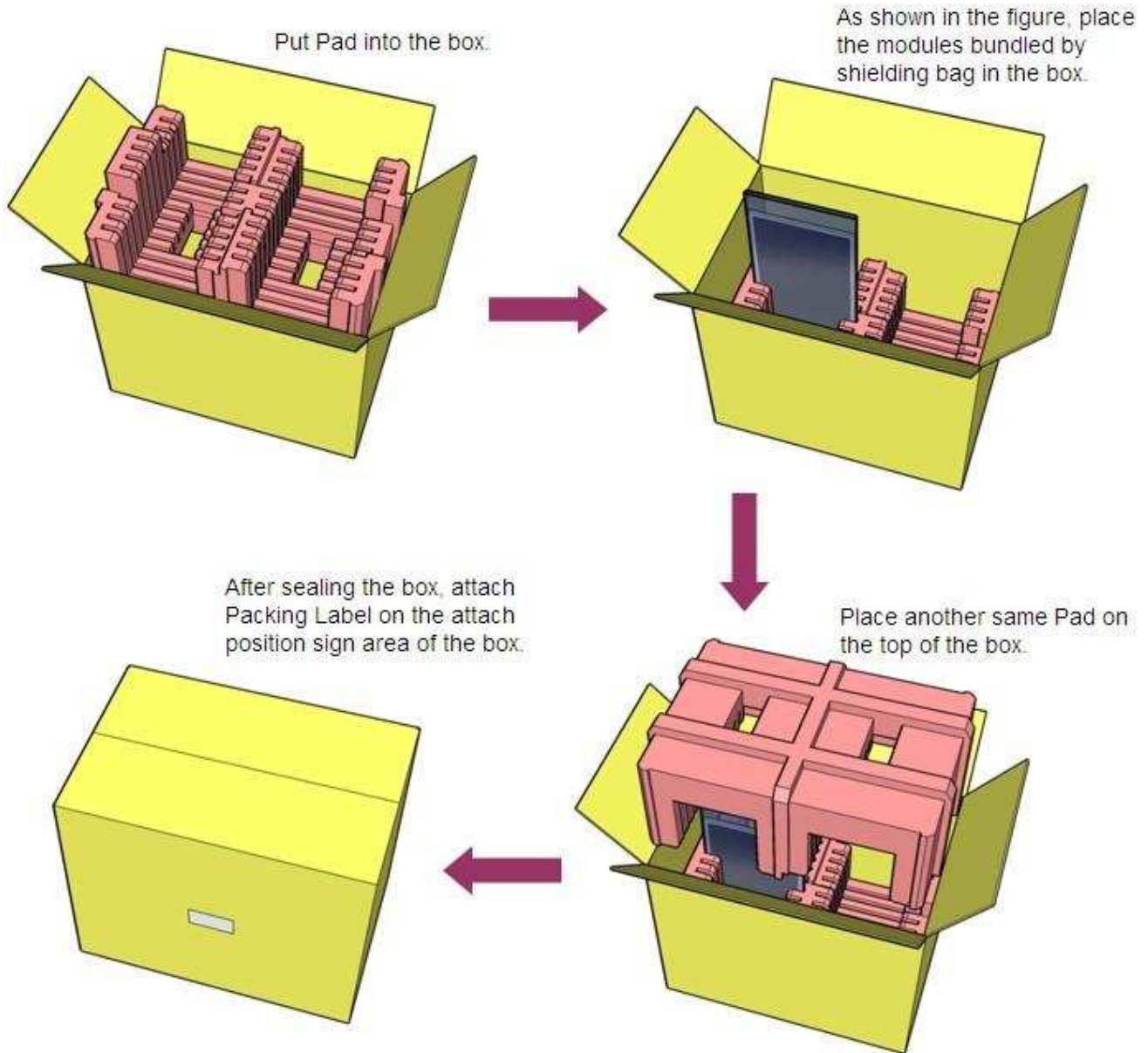

14.2 Notes

- Box Dimension: 526mm(W) x 346mm(D) x 448mm(H)
- Package Quantity in one Box: 24pcs
- Total Weight: 11.5kg

SPEC. NUMBER
S

SPEC TITLE
HT141WXB-100 Preliminary Product Specification

PAGE
25 OF 31



PRODUCT GROUP

REV

ISSUE DATE

TFT LCD PRODUCT

P0

2008.04.18.

15.0 MECHANICAL OUTLINE DIMENSION

Figure 6. TFT-LCD Module Outline Dimension (Front View)

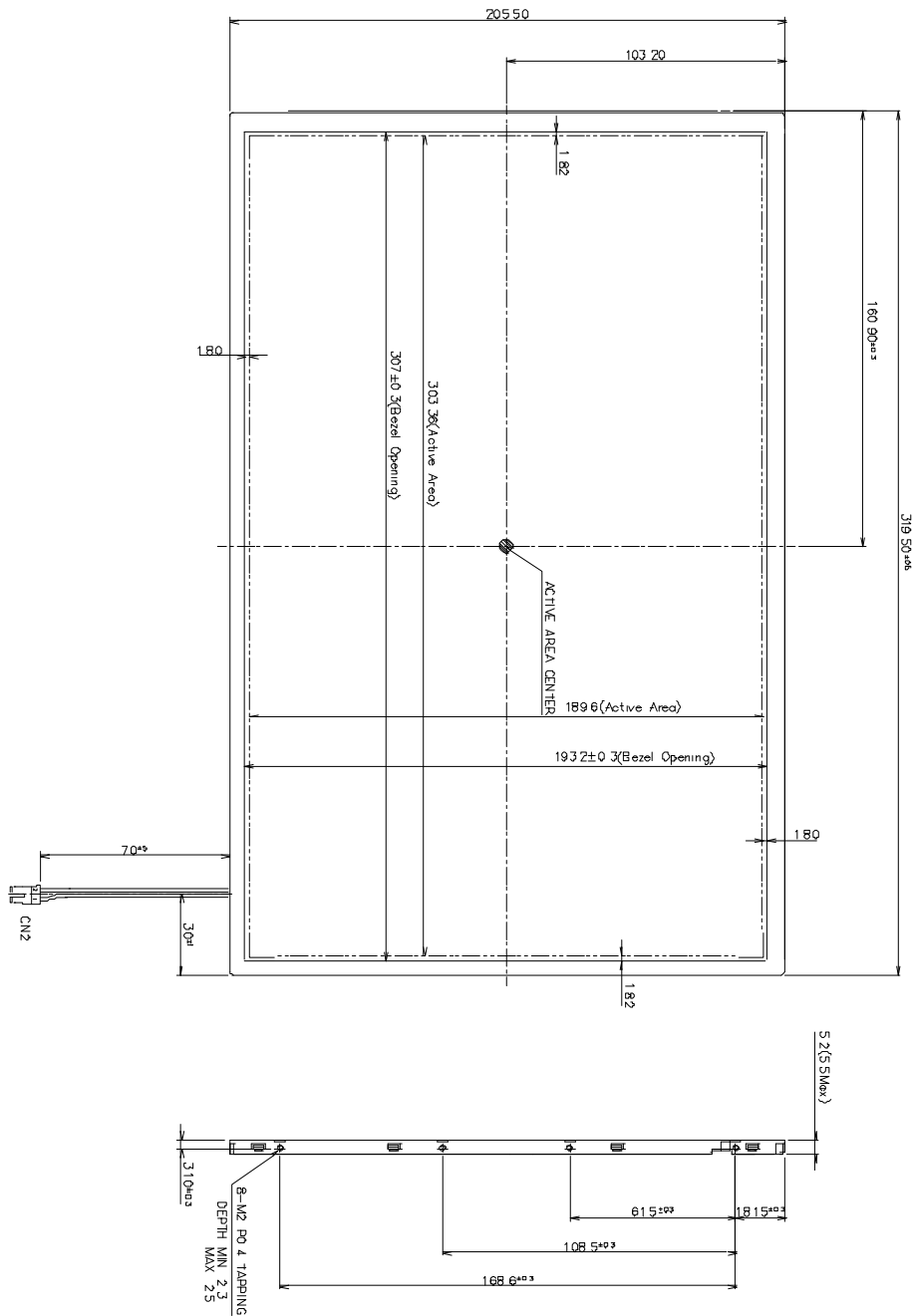

SPEC. NUMBER
S

SPEC TITLE
HT141WXB-100 Preliminary Product Specification

PAGE
26 OF 31

 京东方 BOE	PRODUCT GROUP	REV	ISSUE DATE
	TFT LCD PRODUCT	P0	2008.04.18.

Figure 7. TFT-LCD Module Outline Dimensions (Rear view)

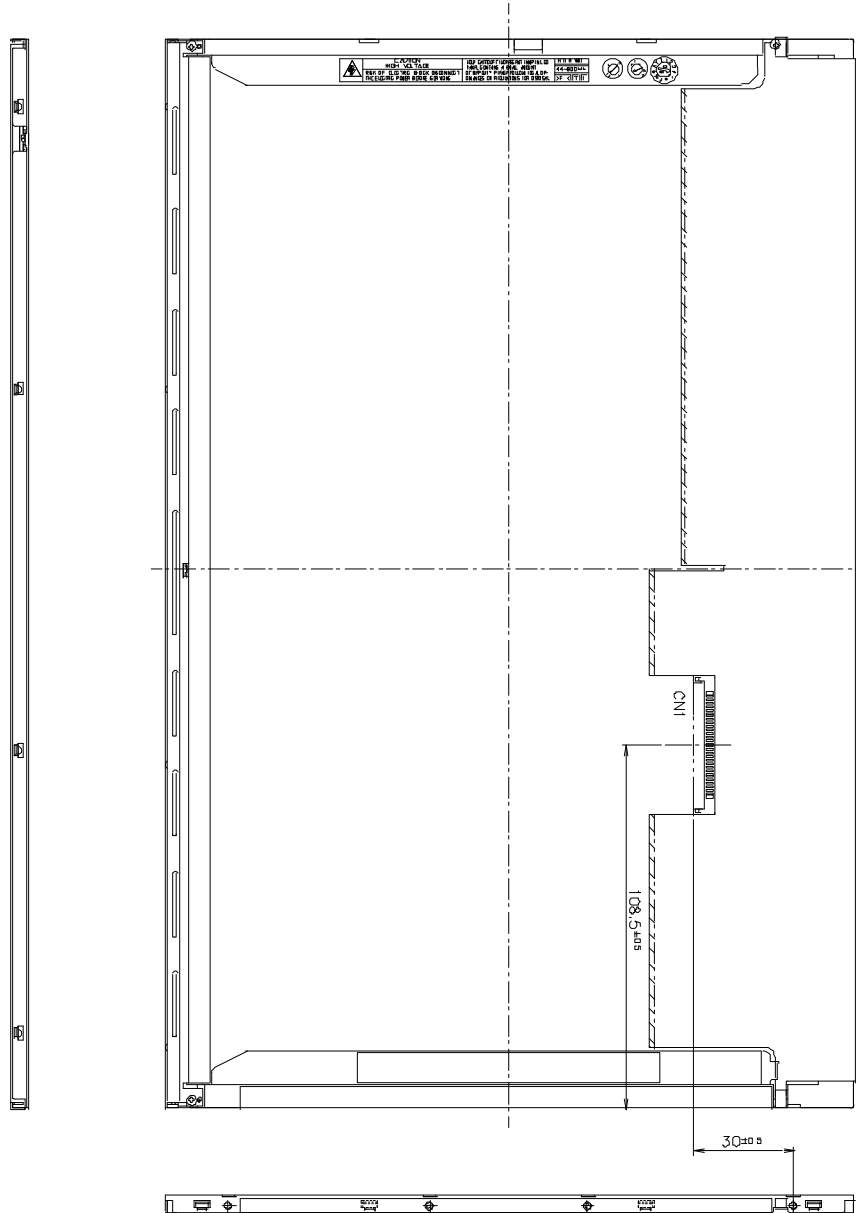

NOTE:
 CN1: UJJ IS100-LSP-C15 OR EQUIVALENT
 CN2: BHSR-02VS-1(2PIN) OR EQUIVALENT
 GENERAL TOLLERANCE: ±0.5

SPEC. NUMBER S	SPEC TITLE HT141WXB-100 Preliminary Product Specification	PAGE 27 OF 31
-------------------	--	------------------

**PRODUCT GROUP**

REV

ISSUE DATE

TFT LCD PRODUCT

P0

2008.04.18.

16.0 EDID Table

Address (HEX)	Function	Hex	Dec	values.	Notes
00	Header	00	0	0	EDID Header
01		FF	255	255	
02		FF	255	255	
03		FF	255	255	
04		FF	255	255	
05		FF	255	255	
06		FF	255	255	
07		00	0	0	
08	ID Manufacturer Name	09	9	BOE	ID = BOE
09		E5	229		
0A	ID Product Code	81	129	1409	ID = 0581 WXGA
0B		05	5		
0C	32-bit serial No.	00	0		
0D		00	0		
0E		00	0		
0F		00	0		
10	Week of manufacture	00	0	0	
11	Year of Manufacture	12	18	2008	Manufactured in 2008
12	EDID Structure Ver.	01	1	1	EDID Ver 1.0
13	EDID revision #	01	1	1	EDID Rev. 0.1
14	Video input definition	80	50	-	
15	Max H image size	1E	30	30	30 cm (Approx)
16	Max V image size	13	19	19	19 cm (Approx)
17	Display Gamma	78	120	2.2	Gamma curve = 2.2
18	Feature support	0A	10		RGB display, Preferred Timming mode
19	Red/Green low bits	62	98	-	Red / Green Low Bits
1A	Blue/White low bits	05	5	-	Blue / White Low Bits
1B	Red x high bits	95	149	0.583	Red (x) = 10010101 (0.58348)
1C	Red y high bits	56	86	0.338	Red (y) = 01010110 (0.33836)
1D	Green x high bits	4E	78	0.305	Green (x) = 01001110 (0.30482)
1E	Green y high bits	8E	142	0.557	Green (y) = 10001110 (0.55656)
1F	Blue x high bits	26	38	0.148	Blue (x) = 00100110 (0.14812)
20	Blue y high bits	24	36	0.141	Blue (y) = 00100100 (0.14068)
21	White x high bits	50	80	0.313	White (x) = 01010000 (0.313)
22	White y high bits	54	84	0.329	White (y) = 01010100 (0.329)

SPEC. NUMBER
SSPEC TITLE
HT141WXB-100 Preliminary Product SpecificationPAGE
28 OF 31



京东方
BOE

PRODUCT GROUP

REV

ISSUE DATE

TFT LCD PRODUCT

P0

2008.04.18.

Address (HEX)	Function	Hex	Dec	values.	Notes
23	Established timing 1	00	0	-	
24	Established timing 2	00	0	-	
25	Established timing 3	00	0	-	
26	Standard timing #1	01	1		Not Used
27		01	1		
28	Standard timing #2	01	1		Not Used
29		01	1		
2A	Standard timing #3	01	1		Not Used
2B		01	1		
2C	Standard timing #4	01	1		Not Used
2D		01	1		
2E	Standard timing #5	01	1		Not Used
2F		01	1		
30	Standard timing #6	01	1		Not Used
31		01	1		
32	Standard timing #7	01	1		Not Used
33		01	1		
34	Standard timing #8	01	1		Not Used
35		01	1		
36	Detailed timing/monitor descriptor #1 (60Hz)	C7	199	71.11	71.11MHz Main clock
37		1B	27		
38		00	0	1280	Hor Active = 1280
39		A0	160	160	Hor Blanking = 160
3A		50	80	-	4 bits of Hor. Active + 4 bits of Hor. Blanking
3B		20	32	800	Ver Active = 800
3C		17	23	23	Ver Blanking = 23
3D		30	48	-	4 bits of Ver. Active + 4 bits of Ver. Blanking
3E		30	48	48	Hor Sync Offset = 48
3F		20	32	32	H Sync Pulse Width = 32
40		36	54	3	V sync Offset = 3 line
41		00	0	6	V Sync Pulse width : 6 line
42		2F	47	303	Horizontal Image Size = 303 mm (Low 8 bits)
43		BE	190	190	Vertical Image Size = 190 mm (Low 8 bits)
44		10	16	-	4 bits of Hor Image Size + 4 bits of Ver Image Size
45		00	0	0	Hor Border (pixels)
46		00	0	0	Vertical Border (Lines)
47	19	25	-		

SPEC. NUMBER
S

SPEC TITLE
HT141WXB-100 Preliminary Product Specification

PAGE
29 OF 31



京东方
BOE

PRODUCT GROUP

REV

ISSUE DATE

TFT LCD PRODUCT

P0

2008.04.18.

Address (HEX)	Function	Hex	Dec	values.	Notes	
48	Detailed timing/monitor descriptor #2	00	0			
49		00	0			
4A		00	0			
4B		FE	0			
4C		00	0			
4D		0A	0			
4E		20	0			
4F		20	0			
50		20	0			
51		20	0			
52		20	0			
53		20	0			
54		20	0			
55		20	0			
56		20	0			
57		20	0			
58	20	0				
59	20	0				
5A	Detailed timing/monitor descriptor #3	00	0		ASCII Data String Tag	
5B		00	0			
5C		00	0			
5D		FE	0			
5E		00	0			
5F		42	66	B	Manufacturer name : BOE OT	
60		4F	79	O		
61		45	69	E		
62		20	32			
63		4F	79	O		
64		54	84	T		
65		0A	10			
66		20	32			
67		20	32			
68	20	32				
69	20	32				
6A	20	32				
6B	20	32				

SPEC. NUMBER
S

SPEC TITLE
HT141WXB-100 Preliminary Product Specification

PAGE
30 OF 31

**PRODUCT GROUP**

REV

ISSUE DATE

TFT LCD PRODUCT

P0

2008.04.18.

Address (HEX)	Function	Hex	Dec	values.	Notes
6C	Detailed timing/monitor descriptor #4	00	0		Product Name Tag (ASCII)
6D		00	0		
6E		00	0		
6F		FE	254		
70		00	0		Model name : HT141WB1-100
71		48	72	H	
72		54	84	T	
73		31	49	1	
74		34	52	4	
75		31	49	1	
76		57	87	W	
77		42	66	B	
78		31	49	1	
79		2D	45	-	
7A		31	49	1	
7B		30	48	0	
7C	30	48	0		
7D	0A	10			
7E	Extension flag	00	0		
7F	Checksum	0A	10	-	

SPEC. NUMBER
SSPEC TITLE
HT141WXB-100 Preliminary Product SpecificationPAGE
31 OF 31