

PATENTED**PAT No. : TW 099352****Technical Document**

- [Tools Information](#)
- [FAQs](#)
- [Application Note](#)

Features

- Operating voltage: 2.7V~5.2V
- Built-in 32kHz RC oscillator
- External 32.768kHz crystal oscillator or 32kHz frequency source input
- Standby current: <1μA at 3V, <2μA at 5V
- Internal resistor type: 1/6 bias or 1/5 bias, 1/32 duty, and 1/16 duty
- Three selectable LCD frame frequencies: 64Hz, 89Hz or 170Hz
- Max. of 64×32 patterns, 64 segments and 32 commons
- 80 segments and 16 commons selectable by command method
- Built-in bit-map display RAM: 2048 bits (=64×32 bits)
- Built-in internal resistor type bias generator
- Six-wire interface (four data wires)
- Eight kinds of time base or WDT selection
- Time base or WDT overflow output
- R/W address auto increment
- Built-in buzzer driver (2kHz/4kHz)
- Power down command reduces power consumption
- Software configuration feature
- Data mode and Command mode instructions
- Three data accessing modes
- Provides VLCD pin to adjust LCD operating voltage and max. VLCD voltage up to 7V
- Provides three kinds of bias current programming
- Control of TN-type and STN-type LCDs
- 128-pin QFP package

Applications

- Leisure products
- Games
- Personal digital assistant
- Cellular phone
- Global positioning system
- Consumer electronics

General Description

HT1650 is a peripheral device specially designed for I/O type MCUs which are used to expand the display capability. The max. display segment of the device are 2048 patterns (64 segments and 32 commons). It also supports four data bits interface, buzzer sound, Watchdog Timer or time base timer functions. The HT1650 is a memory mapping and multi-function LCD controller. It

can control TN-type (Twisted Nematic) or STN-type (Super Twisted Nematic) LCDs. The software configuration feature of the HT1650 make it suitable for multiple LCD applications including LCD modules and display subsystems. Only six lines (\overline{CS} , \overline{WR} , DB0~DB3) are required for the interface between the host controller and the HT1650.

Block Diagram

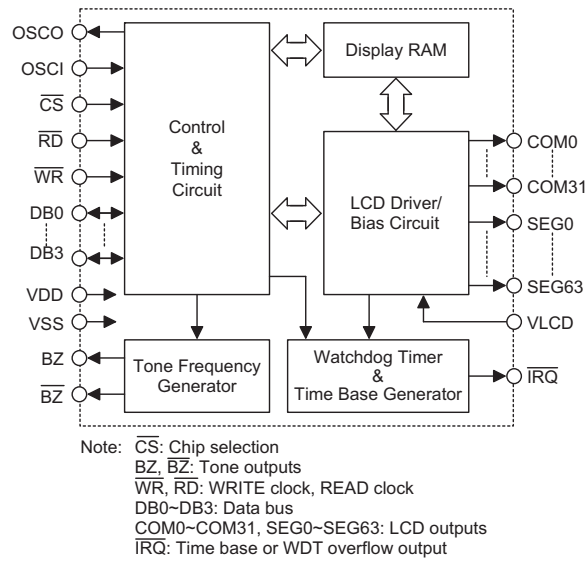

Pin Assignment

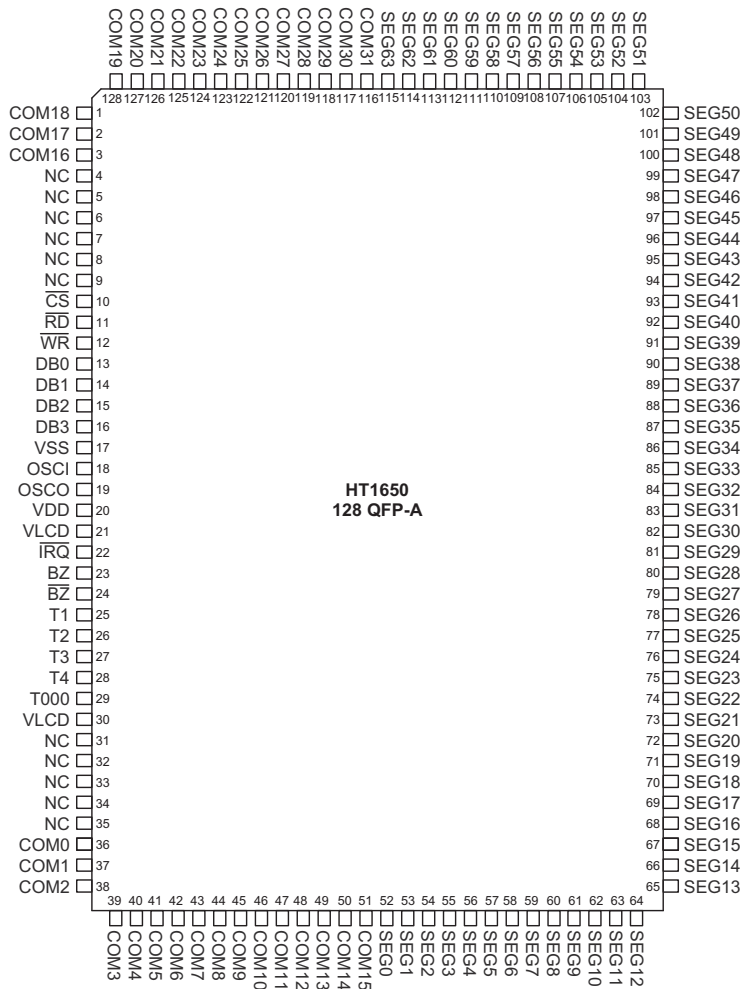

Pad Assignment

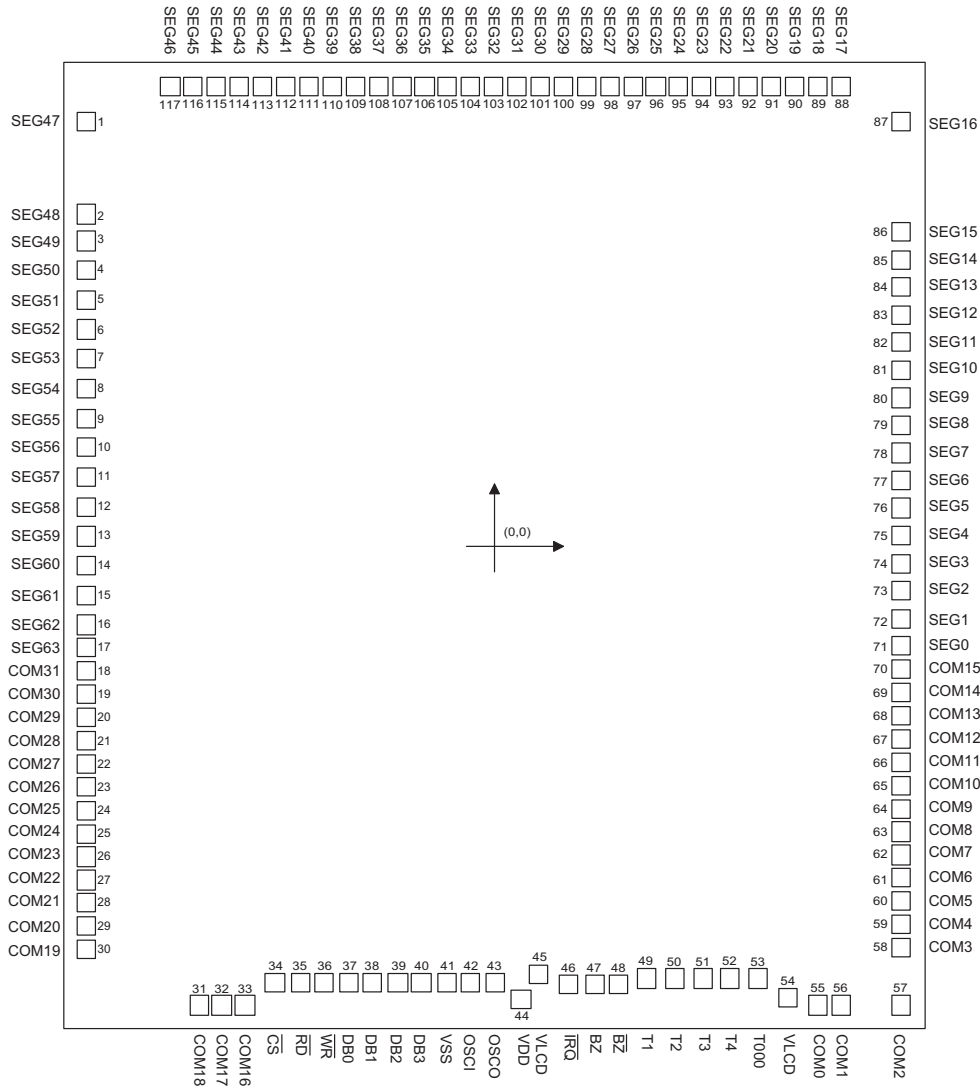

Chip size: 3555×3970 (μm)²

* The IC substrate should be connected to VSS in the PCB layout artwork.

Pad Coordinates

Unit: μm

Pad No.	X	Y	Pad No.	X	Y	Pad No.	X	Y
1	-1672.500	1738.050	40	-297.850	-1784.900	79	1672.500	495.400
2	-1672.500	1359.300	41	-190.500	-1784.900	80	1672.500	608.400
3	-1672.500	1249.300	42	-95.000	-1784.900	81	1672.500	721.400
4	-1672.500	1129.300	43	5.300	-1784.900	82	1672.500	834.400
5	-1672.500	1007.500	44	111.400	-1853.850	83	1672.500	947.400
6	-1672.500	887.500	45	183.950	-1753.850	84	1672.500	1060.400
7	-1672.500	765.700	46	308.850	-1794.400	85	1672.500	1173.400
8	-1672.500	645.700	47	414.450	-1794.400	86	1672.500	1286.400
9	-1672.500	523.900	48	509.450	-1794.400	87	1672.500	1736.100
10	-1672.500	403.900	49	630.250	-1770.250	88	1425.500	1880.000
11	-1672.500	282.100	50	743.850	-1770.250	89	1330.500	1880.000
12	-1672.500	162.100	51	857.450	-1770.250	90	1235.500	1880.000

Pad No.	X	Y	Pad No.	X	Y	Pad No.	X	Y
13	-1672.500	40.300	52	971.050	-1770.250	91	1140.500	1880.000
14	-1672.500	-79.700	53	1084.650	-1770.250	92	1045.500	1880.000
15	-1672.500	-201.500	54	1206.800	-1848.100	93	950.500	1880.000
16	-1672.500	-321.500	55	1330.200	-1880.000	94	855.500	1880.000
17	-1672.500	-416.500	56	1427.200	-1880.000	95	760.500	1880.000
18	-1672.500	-511.500	57	1672.500	-1880.000	96	665.500	1880.000
19	-1672.500	-606.500	58	1672.500	-1643.600	97	570.500	1880.000
20	-1672.500	-701.500	59	1672.500	-1548.600	98	475.500	1880.000
21	-1672.500	-796.500	60	1672.500	-1453.600	99	380.500	1880.000
22	-1672.500	-891.500	61	1672.500	-1358.600	100	285.500	1880.000
23	-1672.500	-986.500	62	1672.500	-1263.600	101	190.500	1880.000
24	-1672.500	-1081.500	63	1672.500	-1168.600	102	95.500	1880.000
25	-1672.500	-1176.500	64	1672.500	-1073.600	103	0.500	1880.000
26	-1672.500	-1271.500	65	1672.500	-978.600	104	-94.500	1880.000
27	-1672.500	-1366.500	66	1672.500	-883.600	105	-189.500	1880.000
28	-1672.500	-1461.500	67	1672.500	-788.600	106	-284.500	1880.000
29	-1672.500	-1556.500	68	1672.500	-693.600	107	-379.500	1880.000
30	-1672.500	-1651.500	69	1672.500	-598.600	108	-474.500	1880.000
31	-1212.700	-1880.000	70	1672.500	-503.600	109	-569.500	1880.000
32	-1117.700	-1880.000	71	1672.500	-408.600	110	-664.500	1880.000
33	-1022.700	-1880.000	72	1672.500	-295.600	111	-759.500	1880.000
34	-899.650	-1784.900	73	1672.500	-182.600	112	-854.500	1880.000
35	-794.050	-1784.900	74	1672.500	-69.600	113	-949.500	1880.000
36	-699.050	-1784.900	75	1672.500	43.400	114	-1044.500	1880.000
37	-593.450	-1784.900	76	1672.500	156.400	115	-1139.500	1880.000
38	-498.450	-1784.900	77	1672.500	269.400	116	-1234.500	1880.000
39	-392.850	-1784.900	78	1672.500	382.400	117	-1329.500	1880.000

Pad Description

Pad No.	Pad Name	I/O	Description
1~17 71~117	SEG47~SEG63 SEG0~SEG46	O	LCD segment outputs
18~33 55~70	COM31~COM16 COM0~COM15	O	LCD common outputs, under 80×16 command mode, COM16~COM31 will be shared with SEG64~SEG79. COM31/SEG64, COM30/SEG65, COM29/SEG66....., COM18/SEG77, COM17/SEG78, COM16/SEG79
34	\overline{CS}	I	Chip selection input with pull-high resistor. When the \overline{CS} is logic high, the data and command read from or write to the HT1650 are disabled. The serial interface circuit is also reset. But if the CS is at a logic low level and is input to the \overline{CS} pad, the data and command transmission between the host controller and the HT1650 are all enabled.
35	\overline{RD}	I	READ clock input with pull-high resistor. Data in the RAM of the HT1650 are clocked out on the falling edge of the \overline{RD} signal. The clocked out data will appear on the data line. The host controller can use the next rising edge to latch the clocked out data.
36	\overline{WR}	I	WRITE clock input with pull-high resistor. Data on the DATA line are latched into the HT1650 on the rising edge of the \overline{WR} signal.
37~40	DB0~DB3	I/O	Parallel data input/output with pull-high resistor
41	VSS	—	Negative power supply for logic circuit, ground
42 43	OSCI OSCO	I O	The OSCI and OSCO pads are connected to a 32.768kHz crystal in order to generate a system clock. If the system clock comes from an external clock source, the external clock source should be connected to the OSCI pad. But if an on-chip RC oscillator is selected, the OSCI and OSCO pads can be left open.
44	VDD	—	Positive power supply for logic circuit
45	VLCD	I	Power supply for LCD driver circuit

Pad No.	Pad Name	I/O	Description
46	IRQ	O	Time base or Watchdog Timer overflow flag, NMOS open drain output.
47, 48	BZ, BZ	O	2kHz or 4kHz frequency output pair (tristate output buffer)
49~53	T1~T4, T000	I	Vary bias current pin It is usually not connected

Absolute Maximum Ratings

Supply Voltage	$V_{SS}-0.3V$ to $V_{SS}+5.5V$	Storage Temperature	$-50^{\circ}C$ to $125^{\circ}C$
Input Voltage	$V_{SS}-0.3V$ to $V_{DD}+0.3V$	Operating Temperature	$-25^{\circ}C$ to $75^{\circ}C$

Note: These are stress ratings only. Stresses exceeding the range specified under "Absolute Maximum Ratings" may cause substantial damage to the device. Functional operation of this device at other conditions beyond those listed in the specification is not implied and prolonged exposure to extreme conditions may affect device reliability.

D.C. Characteristics

Ta=25°C

Symbol	Parameter	Test Conditions		Min.	Typ.	Max.	Unit
		V _{DD}	Conditions				
V _{DD}	Operating Voltage	—	—	2.7	—	5.2	V
I _{DD1}	Operating Current	3V	No load/LCD ON	—	150	250	μA
		5V	On-chip RC oscillator	—	250	370	μA
I _{DD2}	Operating Current	3V	No load/LCD ON	—	135	200	μA
		5V	Crystal oscillator	—	200	300	μA
I _{DD11}	Operating Current	3V	No load/LCD OFF	—	15	30	μA
		5V	On-chip RC oscillator	—	50	70	μA
I _{DD22}	Operating Current	3V	No load/LCD OFF	—	2	10	μA
		5V	Crystal oscillator	—	3	10	μA
I _{STB}	Standby Current	3V	No load, Power down mode	—	—	1	μA
		5V		—	—	2	μA
V _{IL}	Input Low Voltage	3V	DB0~DB3, WR, CS, RD	0	—	0.6	V
		5V		0	—	1.0	V
V _{IH}	Input High Voltage	3V	DB0~DB3, WR, CS, RD	2.4	—	3	V
		5V		4.0	—	5	V
I _{OL1}	BZ, BZ, IRQ Sink Current	3V	V _{OL} =0.3V	1.2	2.5	—	mA
		5V	V _{OL} =0.5V	3	6	—	mA
I _{OH1}	BZ, BZ Source Current	3V	V _{OH} =2.7V	-0.9	-1.8	—	mA
		5V	V _{OH} =4.5V	-2	-4	—	mA
I _{OL2}	DB0~DB3 Sink Current	3V	V _{OL} =0.3V	1.2	2.5	—	mA
		5V	V _{OL} =0.5V	3	6	—	mA
I _{OH2}	DB0~DB3 Source Current	3V	V _{OH} =2.7V	-0.9	-1.8	—	mA
		5V	V _{OH} =4.5V	-2	-4	—	mA
I _{OL3}	LCD Common Sink Current	3V	V _{OL} =0.3V	80	160	—	μA
		5V	V _{OL} =0.5V	180	360	—	μA
I _{OH3}	LCD Common Source Current	3V	V _{OH} =2.7V	-40	-80	—	μA
		5V	V _{OH} =4.5V	-90	-180	—	μA

Symbol	Parameter	Test Conditions		Min.	Typ.	Max.	Unit
		V _{DD}	Conditions				
I _{OL4}	LCD Segment Sink Current	3V	V _{OL} =0.3V	50	100	—	μA
		5V	V _{OL} =0.5V	120	240	—	μA
I _{OH4}	LCD Segment Source Current	3V	V _{OH} =2.7V	-30	-60	—	μA
		5V	V _{OH} =4.5V	-70	-140	—	μA
R _{PH}	Pull-high Resistor	3V	DB0~DB3, \overline{WR} , \overline{CS} , \overline{RD}	150	250	410	kΩ
		5V	DB0~DB3, \overline{WR} , \overline{CS} , \overline{RD}	60	125	210	kΩ

A.C. Characteristics

T_a=25°C

Symbol	Parameter	Test Conditions		Min.	Typ.	Max.	Unit
		V _{DD}	Conditions				
f _{SYS1}	System Clock	3V	On-chip RC oscillator	22	32	40	kHz
		5V		24	32	40	kHz
f _{SYS2}	System Clock	3V	Crystal oscillator	—	32.768	—	kHz
		5V		—	32.768	—	kHz
f _{SYS3}	System Clock	3V	External clock source	—	32	—	kHz
		5V		—	32	—	kHz
f _{LCD1}	LCD Frame Frequency	3V	On-chip RC oscillator	61/117	89/170	111/213	Hz
		5V		61/117	89/170	111/213	Hz
f _{LCD2}	LCD Frame Frequency	3V	Crystal oscillator	—	64	—	Hz
		5V		—	64	—	Hz
f _{LCD3}	LCD Frame Frequency	3V	External clock source	—	64	—	Hz
		5V		—	64	—	Hz
t _{COM}	LCD Common Period	—	n: Number of COM	—	n/f _{LCD}	—	sec
f _{CLK1}	4-Bit Data Clock (\overline{WR} Pin)	3V	Duty cycle 50%	—	—	150	kHz
		5V		—	—	300	kHz
f _{CLK2}	4-Bit Data Clock (\overline{RD} Pin)	3V	Duty cycle 50%	—	—	75	kHz
		5V		—	—	150	kHz
t _{CS}	4-Bit Interface Reset Pulse Width (Figure 3)	—	\overline{CS}	—	250	—	ns
t _{CLK}	\overline{WR} , \overline{RD} Input Pulse Width (Figure 1)	3V	Write mode	3.34	—	—	μs
			Read mode	6.67	—	—	μs
		5V	Write mode	1.67	—	—	μs
			Read mode	3.34	—	—	μs
t _r , t _f	Rise/Fall Time Serial Data Clock Width (Figure 1)	3V	—	—	120	160	ns
		5V		—	120	160	ns
t _{su}	Setup Time for DB to \overline{WR} , \overline{RD} Clock Width (Figure 2)	3V	—	80	120	—	ns
		5V		80	120	—	ns
t _h	Hold Time for DB to \overline{WR} , \overline{RD} Clock Width (Figure 2)	3V	—	60	120	—	ns
		5V		60	120	—	ns
t _{su1}	Setup Time for \overline{CS} to \overline{WR} , \overline{RD} Clock Width (Figure 3)	3V	—	50	100	—	ns
		5V		50	100	—	ns
t _{h1}	Hold Time for \overline{CS} to \overline{WR} , \overline{RD} Clock Width (Figure 3)	3V	—	60	120	—	ns
		5V		60	120	—	ns

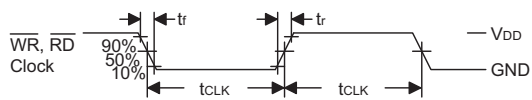

Figure 1

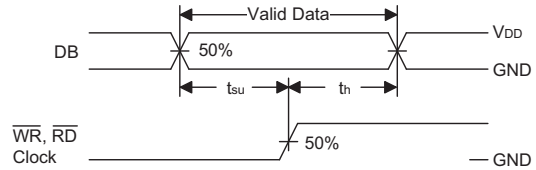

Figure 2

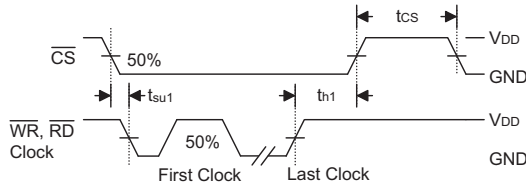

Figure 3

Functional Description

System Oscillator

The HT1650 system clock is used to generate the time base or Watchdog Timer (WDT) clock frequency, LCD driving clock, and tone frequency. The clock source may be from an on-chip RC oscillator (32kHz), a crystal oscillator (32.768kHz), or an external 32kHz clock by the S/W setting. The configuration of the system oscillator is as shown. After the SYS DIS command is executed, the system clock will stop and the LCD bias generator will turn off. That command is available only for the on-chip RC oscillator or for the crystal oscillator. Once the system clock stops, the LCD display will become blank, and the time base/WDT loses its function as well.

The LCD OFF command is used to turn the LCD bias generator off. After the LCD bias generator switches off by issuing the LCD OFF command, using the SYS DIS command reduces power consumption, thus serving as a system power down command. But if the external clock source is chosen as the system clock, using the SYS DIS command can neither turn the oscillator off nor carry out the power down mode. The crystal oscillator option can be applied to connect an external frequency source of 32kHz to the OSCi pin. In this case, the system fails to enter the power down mode, similar to the case of the external 32kHz clock source operation. At the initial system power on, the HT1650 is at the SYS DIS state.

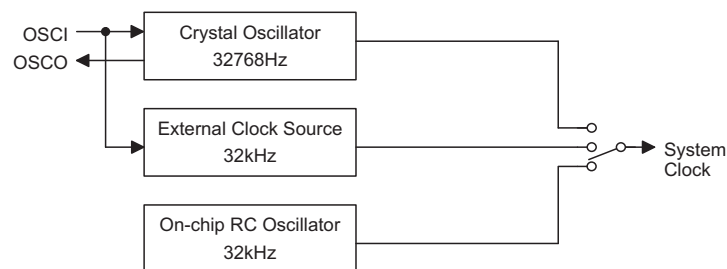

System Oscillator Configuration

Display Memory – RAM Structure

The static display RAM is organized into 512×4 bits and stores the display data. The contents of the RAM are directly mapped to the contents of the LCD driver. Data in the RAM can be accessed by the READ, WRITE and READ-MODIFY-WRITE commands. The following is a mapping from the RAM to the LCD patterns.

	00H	08H	10H	18H	20H - - - - - 1D8H	1E0H	1E8H	1F0H	1F8H
COM0	Bit0	Bit0					Bit0	Bit0	Bit0
COM1	Bit1	Bit1					Bit1	Bit1	Bit1
COM2	Bit2	Bit2					Bit2	Bit2	Bit2
COM3	Bit3	Bit3					Bit3	Bit3	Bit3
	01H	09H	11H	19H	21H - - - - - 1D9H	1E1H	1E9H	1F1H	1F9H
COM4	Bit0	Bit0					Bit0	Bit0	Bit0
COM5	Bit1	Bit1					Bit1	Bit1	Bit1
COM6	Bit2	Bit2					Bit2	Bit2	Bit2
COM7	Bit3	Bit3					Bit3	Bit3	Bit3
	02H	0AH	12H	1AH	22H - - - - - 1DAH	1E2H	1EAH	1F2H	1FAH
COM8	Bit0	Bit0					Bit0	Bit0	Bit0
COM9	Bit1	Bit1					Bit1	Bit1	Bit1
COM10	Bit2	Bit2					Bit2	Bit2	Bit2
COM11	Bit3	Bit3					Bit3	Bit3	Bit3
	03H	0BH	13H	1BH	23H - - - - - 1DBH	1E3H	1EBH	1F3H	1FBH
COM12	Bit0	Bit0	Bit0				Bit0	Bit0	Bit0
COM13	Bit1	Bit1	Bit1				Bit1	Bit1	Bit1
COM14	Bit2	Bit2	Bit2				Bit2	Bit2	Bit2
COM15	Bit3	Bit3	Bit3				Bit3	Bit3	Bit3
	04H	0CH	14H	1CH	24H - - - - - 1DCH	1E4H	1ECH	1F4H	1FCH
COM16	Bit0	Bit0	Bit0				Bit0	Bit0	Bit0
COM17	Bit1	Bit1	Bit1				Bit1	Bit1	Bit1
COM18	Bit2	Bit2	Bit2				Bit2	Bit2	Bit2
COM19	Bit3	Bit3	Bit3				Bit3	Bit3	Bit3
	05H	0DH	15H	1DH	25H - - - - - 1DDH	1E5H	1EDH	1F5H	1FDH
COM20	Bit0	Bit0	Bit0				Bit0	Bit0	Bit0
COM21	Bit1	Bit1	Bit1				Bit1	Bit1	Bit1
COM22	Bit2	Bit2	Bit2				Bit2	Bit2	Bit2
COM23	Bit3	Bit3	Bit3				Bit3	Bit3	Bit3
	06H	0EH	16H	1EH	26H - - - - - 1DEH	1E6H	1EEH	1F6H	1FEH
COM24	Bit0	Bit0	Bit0				Bit0	Bit0	Bit0
COM25	Bit1	Bit1	Bit1				Bit1	Bit1	Bit1
COM26	Bit2	Bit2	Bit2				Bit2	Bit2	Bit2
COM27	Bit3	Bit3	Bit3				Bit3	Bit3	Bit3
	07H	0FH	17H	1FH	27H - - - - - 1DFH	1E7H	1EFH	1F7H	1FFH
COM28	Bit0	Bit0	Bit0				Bit0	Bit0	Bit0
COM29	Bit1	Bit1	Bit1				Bit1	Bit1	Bit1
COM30	Bit2	Bit2	Bit2				Bit2	Bit2	Bit2
COM31	Bit3	Bit3	Bit3				Bit3	Bit3	Bit3
	SEG0	SEG1	SEG2	SEG3		SEG60	SEG61	SEG62	SEG63

64×32 Selection Mode RAM Mapping Table

	00H	04H	08H	0CH	10H - - - - - 12CH	130H	134H	138H	13CH
COM0	Bit0	Bit0					Bit0	Bit0	Bit0
COM1	Bit1	Bit1					Bit1	Bit1	Bit1
COM2	Bit2	Bit2					Bit2	Bit2	Bit2
COM3	Bit3	Bit3					Bit3	Bit3	Bit3
	01H	05H	09H	0DH	11H - - - - - 12DH	131H	135H	139H	13DH
COM4	Bit0	Bit0					Bit0	Bit0	Bit0
COM5	Bit1	Bit1					Bit1	Bit1	Bit1
COM6	Bit2	Bit2					Bit2	Bit2	Bit2
COM7	Bit3	Bit3					Bit3	Bit3	Bit3
	02H	06H	0AH	0EH	12H - - - - - 12EH	132H	136H	13AH	13EH
COM8	Bit0	Bit0					Bit0	Bit0	Bit0
COM9	Bit1	Bit1					Bit1	Bit1	Bit1
COM10	Bit2	Bit2					Bit2	Bit2	Bit2
COM11	Bit3	Bit3					Bit3	Bit3	Bit3
	03H	07H	0BH	0FH	13H - - - - - 12FH	133H	137H	13BH	13FH
COM12	Bit0	Bit0	Bit0				Bit0	Bit0	Bit0
COM13	Bit1	Bit1	Bit1				Bit1	Bit1	Bit1
COM14	Bit2	Bit2	Bit2				Bit2	Bit2	Bit2
COM15	Bit3	Bit3	Bit3				Bit3	Bit3	Bit3
	SEG0	SEG1	SEG2	SEG3		SEG76	SEG77	SEG78	SEG79

80×16 Selection Mode RAM Mapping Table

Name	Command Code	Function
80×16 Mode	X100-0001-1111-XXXX	Change segment from 64 to 80 and common from 32 to 16
The default value after power ON reset is 64×32 mode, set "Normal" command will change 80×16 mode to 64×32 mode.		

Frame Frequency

The HT1650 provides three kinds of frame frequency options by command code; 64Hz, 89Hz and 170Hz respectively. FRAME 64Hz provides 64Hz frame frequency. FRAME 89Hz provides 89Hz frame frequency. FRAME 170Hz provides 170Hz frame frequency.

Name	Command Code	Function
FRAME 170Hz	X100-0001-1000-XXXX	Select 170Hz frame frequency
FRAME 89Hz	X100-0001-1101-XXXX	Select 89Hz frame frequency
FRAME 64Hz	X100-0001-1110-XXXX	Select 64Hz frame frequency

Frame Frequency Selection Command Code

Time Base and Watchdog Timer – WDT

The time base generator and WDT share the same counter which is divided by 256. The \overline{IRQ} clock can be programmed as 1Hz, 2Hz, ..., 128Hz output. TIMER DIS/EN/CLR, WDT DIS/EN/CLR and \overline{IRQ} EN/DIS are independent from each other. Once the WDT time-out occurs, the \overline{IRQ} pin will remain at a logic low level until the CLR WDT or the \overline{IRQ} DIS command is issued.

If an external clock is selected as the system frequency source, the SYS DIS command turns out invalid and the power down mode fails to be carried out until the external clock source is removed.

Buzzer Tone Output

A simple tone generator is implemented in the HT1650. The tone generator can output a pair of differential driving signals on the BZ and \overline{BZ} which are used to generate a single tone.

By executing the TONE 4K and TONE 2K commands there are two tone frequency outputs selectable that can turn on the tone output. The TONE 4K and TONE 2K commands set the tone frequency to 4kHz and 2kHz, respectively. The tone output can be turned off by invoking the TONE OFF command. The tone outputs, namely, BZ and \overline{BZ} , are a pair of differential driving outputs used to drive a piezo buzzer. Once the system is disabled or the tone output is inhibited, the BZ and the \overline{BZ} outputs will remain at low level.

Command Format

The HT1650 can be configured by software setting. There are two mode commands to configure the HT1650 resource and to transfer the LCD display data.

The configuration mode of the HT1650 is called command mode, and its command mode ID is 100. The command mode consists of a system configuration

command, a system frequency selection command, an LCD configuration command, a tone frequency selection command, a bias current selection command, a timer/WDT setting command, and an operating command. The data mode, on the other hand, includes READ, WRITE, and READ-MODIFY-WRITE operations.

The following are the data mode ID and the command mode ID:

Operation	Mode	ID
READ	Data	110
WRITE	Data	101
READ-MODIFY-WRITE	Data	101
COMMAND	Command	100

If successive commands have been issued, the command mode ID can be omitted. While the system is operating in the non-successive command or the non-successive address data mode, the \overline{CS} pin should be set to "1" and the previous operation mode will also be reset. The \overline{CS} pin returns to "0", so a new operation mode ID should be issued first.

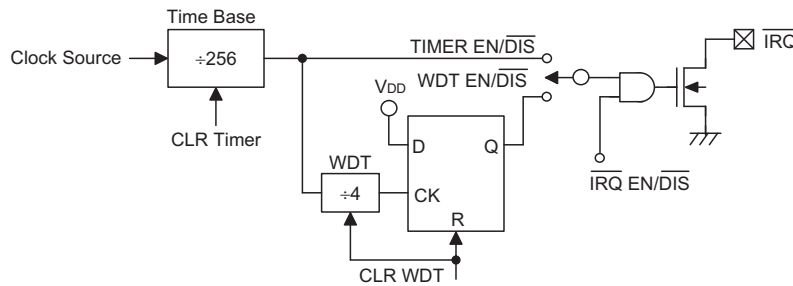

Time Base and WDT Configurations

Name	Command Code	Function
TONE OFF	X100-0000-1000-XXXX	Turn-off the tone output
TONE 4K	X100-0001-0000-XXXX	Turn-on the tone output, the tone frequency is 4kHz
TONE 2K	X100-0001-0001-XXXX	Turn-on the tone output, the tone frequency is 2kHz

Buzzer Tone Output Command Code

The following are the data mode ID and the command ID:

Operation	Mode	ID
READ	Data	110
WRITE	Data	101
READ-MODIFY-WRITE	Data	101
COMMAND	Command	100

If successive commands have been issued, the command mode ID can be omitted. While the system is operating in the non-successive address data mode, the \overline{CS} pin should be set to "1" and the previous operation mode will also be reset. The \overline{CS} pin returns to "0", so a new operation mode ID should be issued first.

Bias Generator

The HT1650 bias voltage belongs to the internal resistor type. It provides two kinds of bias options, namely 1/6 bias and 1/5 bias respectively. It also provides three kinds of bias current options by programming to suitably drive an LCD panel. The three kinds of bias current are large, middle, and small, respectively. Usually, large panel LCD can be excellently displayed by large bias current. Relatively, it consumes large current when LCD ON command is used. Small bias current provides low power consumption during on condition when the LCD is normally displayed. The following are the reference value table.

When the bias current for LCD is more than Large Bias Current setting. It is recommended to add external circuit to increase driving current.

Interfacing

Only six lines are required to interface with the HT1650. The CS line is used to initialize the serial interface circuit and to terminate the communication between the host controller and the HT1650. If the CS pin is set to 1, the

data and command issued between the host controller and the HT1650 are first disabled and then initialized. Before issuing a mode command or mode switching, a high level pulse is required to initialize the serial interface of the HT1650. The DB0~DB3 are the 4-bit parallel data input/output lines. Data to be read or written or commands to be written have to pass through the DB0~DB3 lines. The RD line is the READ clock input. Data in the RAM are clocked out on the falling edge of the RD signal, and the clocked out data will then appear on the DB0~DB3 lines. It is recommended that the host controller read correct data during the interval between the rising edge and the next falling edge of the RD signal. The WR line is the WRITE clock input. The data, address, and command on the DB0~DB3 lines are all clocked into the HT1650 on the rising edge of the WR signal. There is an optional IRQ line to be used as an interface between the host controller and the HT1650. The IRQ pin can be selected as a timer output or a WDT overflow flag output by the S/W setting. The host controller can perform the time base or the WDT function by connecting with the IRQ pin of the HT1650.

Bias	VLCD	Large Bias Current	Middle Bias Current	Small Bias Current
1/5	3V	165μA	70μA	30μA
	5V	270μA	110μA	50μA
1/6	3V	140μA	55μA	25μA
	5V	225μA	90μA	40μA

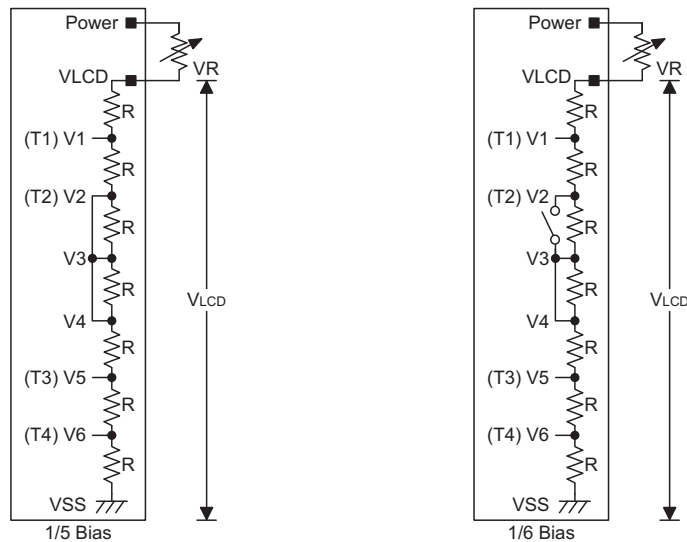

Internal Resistor Type Bias Generator Configurations

Note: The voltage applied to VLCD pin must be equal to or lower than 7V.
Adjust VR to fit LCD display.

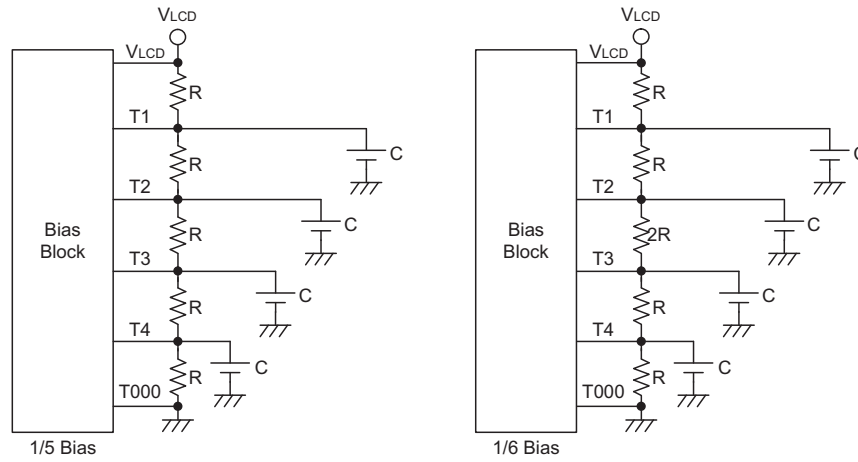

Increase Driver Current Configurations

Note: The external resistors are used to increment the driving current.
 And the external capacitors are used to keep the bias voltage stable.

Timing Diagrams

READ Mode (Command ID Code: 1 1 0)

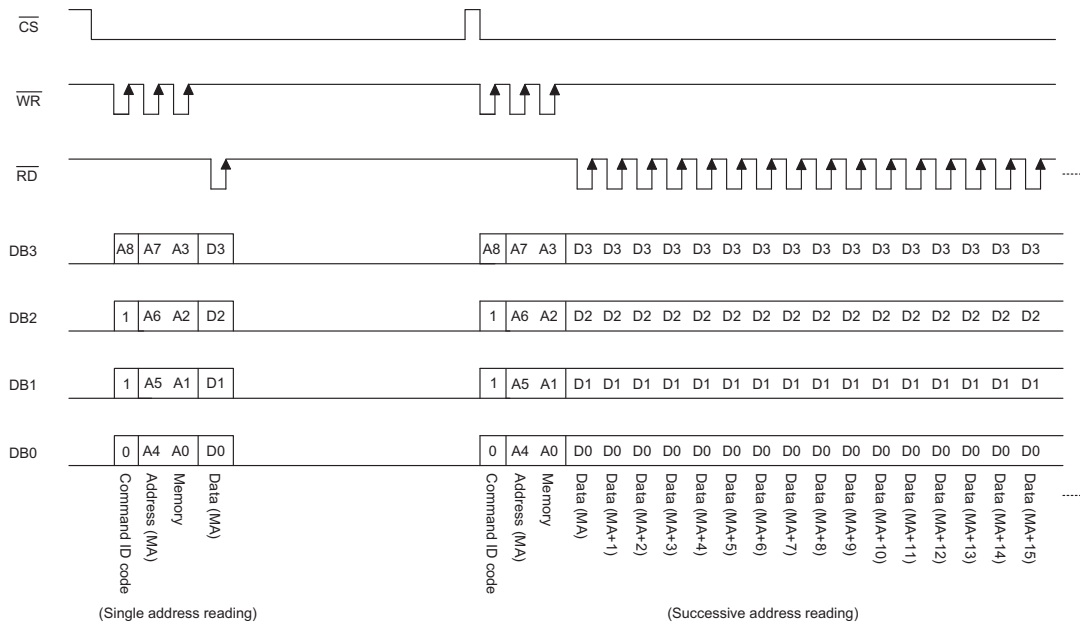

WRITE Mode (Command ID Code: 1 0 1)

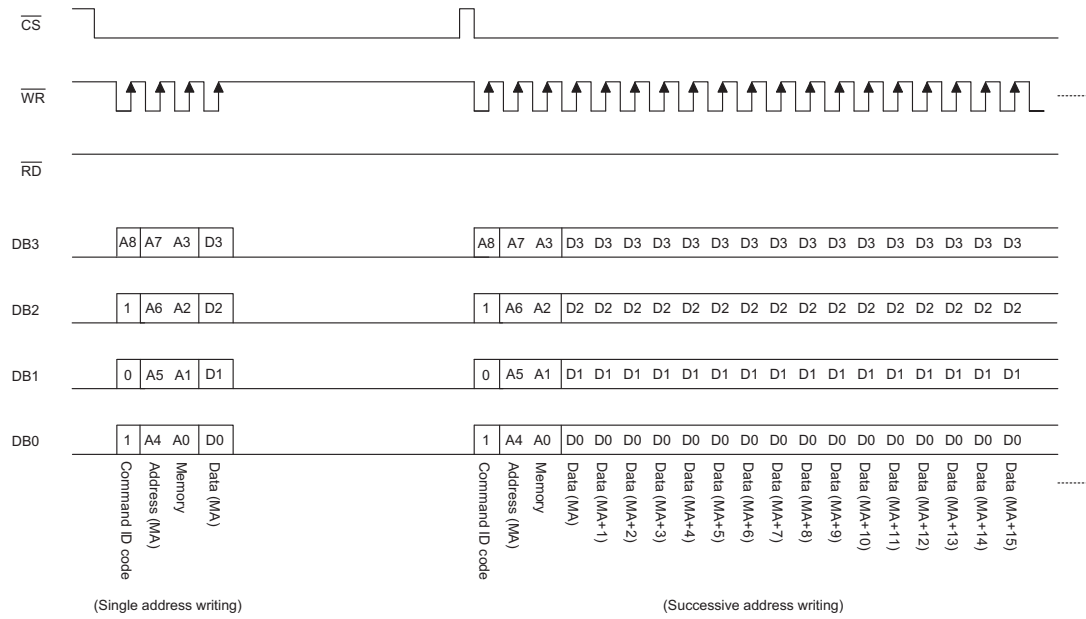

READ-MODIFY-WRITE Mode (Command ID Code: 1 0 1)

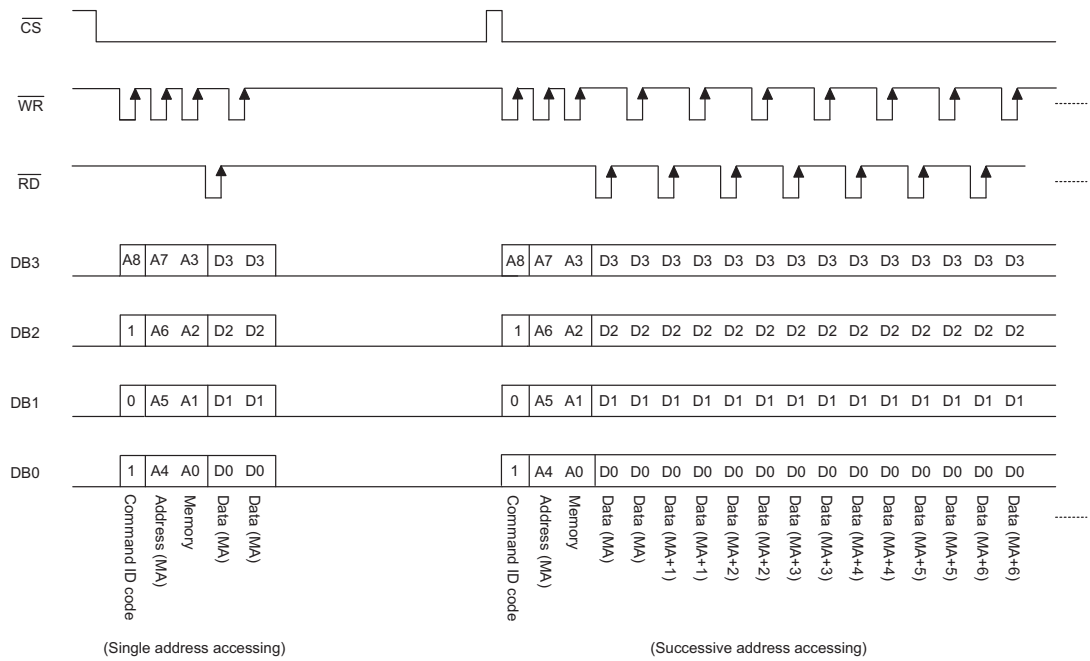

Command Mode (Command ID Code: 1 0 0)

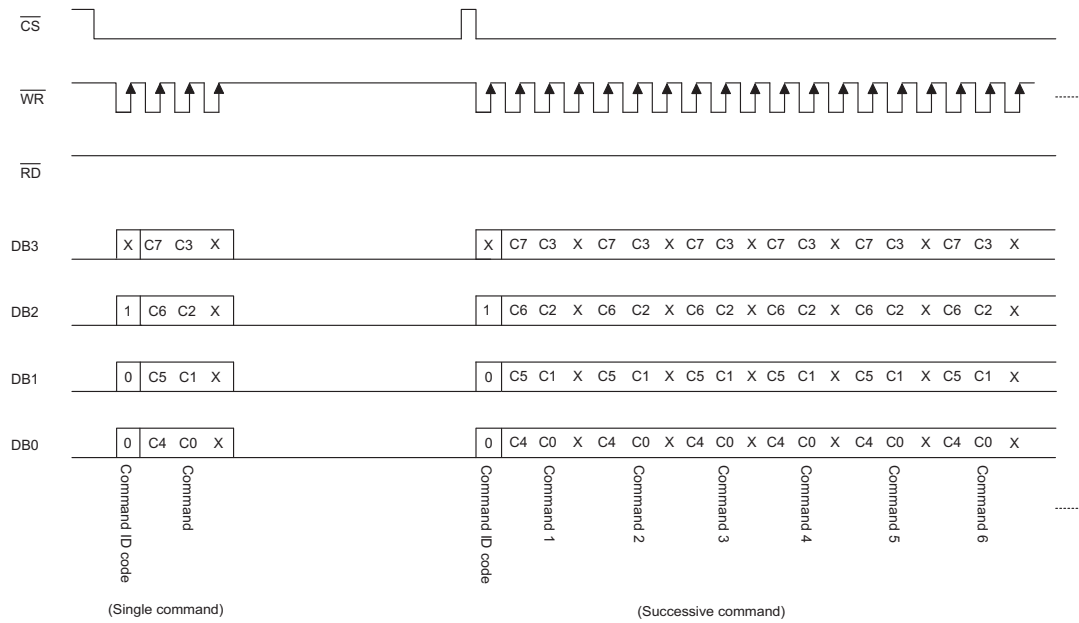

Note: "X" stands for don't care

Application Circuits

Host Controller With an HT1650 Display System

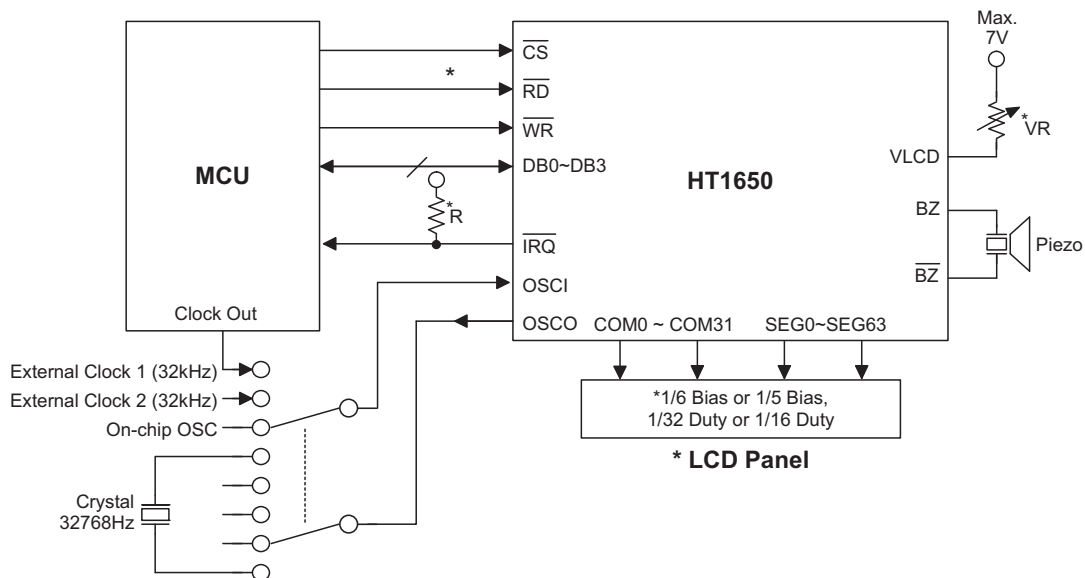

*Note: The connection of \overline{IRQ} and \overline{RD} pin can be selected depending on the MCU.

Adjust VR to fit LCD display

Adjust R (external pull-high resistance) to fit user's time base clock.

It is recommended that the internal equivalent capacitance between SEG and COM of LCD panel should be lower than 10pF. (LCR meter test condition: frequency in 1KHz)

Instruction Set Summary

Name	Command Code	D/C	Function	Def.
READ	A8110-A7A6A5A4A3A2A1A0D3D2D1D0	D	Read data from the RAM	
WRITE	A8101-A7A6A5A4A3A2A1A0D3D2D1D0	D	Write data to the RAM	
READ-MODIFY-WRITE	A8101-A7A6A5A4A3A2A1A0D3D2D1D0	D	Read from and Write data to the RAM	
SYS DIS	X100-0000-0000-XXXX	C	Turn Off both system oscillator and LCD bias generator	Yes
SYS EN	X100-0000-0001-XXXX	C	Turn On system oscillator	
LCD OFF	X100-0000-0010-XXXX	C	Turn Off LCD display	Yes
LCD ON	X100-0000-0011-XXXX	C	Turn On LCD display	
TIMER DIS	X100-0000-0100-XXXX	C	Disable time base output	Yes
WDT DIS	X100-0000-0101-XXXX	C	Disable WDT time-out flag output	Yes
TIMER EN	X100-0000-0110-XXXX	C	Enable time base output	
WDT EN	X100-0000-0111-XXXX	C	Enable WDT time-out flag output	
TONE OFF	X100-0000-1000-XXXX	C	Turn Off tone outputs	Yes
CLR TIMER	X100-0000-1101-XXXX	C	Clear the contents of the time base generator	
CLR WDT	X100-0000-1111-XXXX	C	Clear the contents of the WDT stage	
TONE 4K	X100-0001-0000-XXXX	C	Turn on tone output, tone frequency output: 4kHz	
TONE 2K	X100-0001-0001-XXXX	C	Turn on tone output, tone frequency output: 2kHz	
IRQ DIS	X100-0001-0010-XXXX	C	Disable $\overline{\text{IRQ}}$ output	Yes
IRQ EN	X100-0001-0011-XXXX	C	Enable $\overline{\text{IRQ}}$ output	
RC 32K	X100-0001-0100-XXXX	C	System clock source, on-chip RC oscillator	Yes
EXT (X'TAL)	X100-0001-0101-XXXX	C	System clock source, external 32kHz clock source or crystal oscillator 32.768kHz	
LARGE BIAS	X100-0001-0110-XXXX	C	Large bias current option	Yes
MIDDLE BIAS	X100-0001-0111-XXXX	C	Middle bias current option	
SMALL BIAS	X100-0001-1000-XXXX	C	Small bias current option	
BIAS 1/6	X100-0001-1010-XXXX	C	LCD 1/6 bias option	Yes
BIAS 1/5	X100-0001-1001-XXXX	C	LCD 1/5 bias option	
FRAME 170Hz	X100-0001-1100-XXXX	C	Selects 170Hz frame frequency	
FRAME 89Hz	X100-0001-1101-XXXX	C	Selects 89Hz frame frequency	
FRAME 64Hz	X100-0001-1110-XXXX	C	Selects 64Hz frame frequency	Yes
Select 80x16	X100-0001-1111-XXXX	C	This command will change segment from 64 to 80 and common from 32 to 16	
F1	X100-1010-0000-XXXX	C	Time base clock output: 1Hz The WDT time-out flag after 4s	
F2	X100-1010-0001-XXXX	C	Time base clock output: 2Hz The WDT time-out flag after 2s	
F4	X100-1010-0010-XXXX	C	Time base clock output: 4Hz The WDT time-out flag after 1s	

Name	Command Code	D/C	Function	Def.
F8	X 100 -1010-0011-XXXX	C	Time base clock output: 8Hz The WDT time-out flag after 1/2s	
F16	X 100 -1010-0100-XXXX	C	Time base clock output: 16Hz The WDT time-out flag after 1/4s	
F32	X 100 -1010-0101-XXXX	C	Time base clock output: 32Hz The WDT time-out flag after 1/8s	
F64	X 100 -1010-0110-XXXX	C	Time base clock output: 64Hz The WDT time-out flag after 1/16s	
F128	X 100 -1010-0111-XXXX	C	Time base clock output: 128Hz The WDT time-out flag after 1/32s	Yes
TEST	X 100 -1111-1111-XXXX	C	Test mode, not for use by the user	
NORMAL	X 100 -1111-1110-XXXX	C	Normal mode, 64×32 mode will be set	Yes

Note: "X" stands for don't care

A8~A0: RAM address

D3~D0: RAM data

D/C: Data/Command mode

Def.: Power-on reset default

All the bold forms, namely, **1 1 0**, **1 0 1**, and **1 0 0**, are mode commands. Of these, **1 0 0** indicates the command mode ID. If successive commands have been issued, the command mode ID except for the first command will be omitted. The tone frequency source and the time base or WDT clock frequency source can be derived from an on-chip 32kHz RC oscillator, a 32.768kHz crystal oscillator, or an external 32kHz clock. Calculation of the frequency is based on the system frequency sources as stated above. It is recommended that the host controller should initialize the HT1650 after power-on reset, otherwise, power on reset may fail, which in turn leads to the malfunctioning of the HT1650.

Package Information

128-pin QFP (14mm×20mm) Outline Dimensions

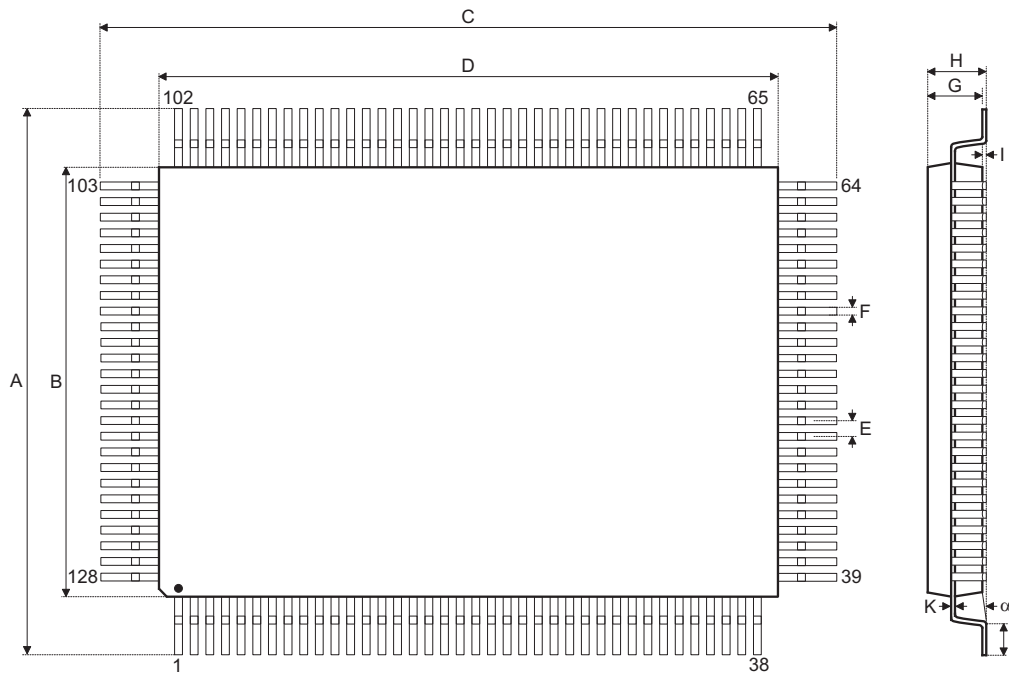

Symbol	Dimensions in inch		
	Min.	Nom.	Max.
A	0.669	—	0.689
B	0.547	—	0.555
C	0.906	—	0.925
D	0.783	—	0.791
E	—	0.020	—
F	—	0.008	—
G	0.098	—	0.122
H	—	—	0.134
I	—	0.004	—
J	0.026	—	0.037
K	0.004	—	0.008
α	0°	—	7°

Symbol	Dimensions in mm		
	Min.	Nom.	Max.
A	17.00	—	17.50
B	13.90	—	14.10
C	23.00	—	23.50
D	19.90	—	20.10
E	—	0.50	—
F	—	0.20	—
G	2.50	—	3.10
H	—	—	3.40
I	—	0.10	—
J	0.65	—	0.95
K	0.10	—	0.20
α	0°	—	7°

Copyright © 2011 by HOLTEK SEMICONDUCTOR INC.

The information appearing in this Data Sheet is believed to be accurate at the time of publication. However, Holtek assumes no responsibility arising from the use of the specifications described. The applications mentioned herein are used solely for the purpose of illustration and Holtek makes no warranty or representation that such applications will be suitable without further modification, nor recommends the use of its products for application that may present a risk to human life due to malfunction or otherwise. Holtek's products are not authorized for use as critical components in life support devices or systems. Holtek reserves the right to alter its products without prior notification. For the most up-to-date information, please visit our web site at <http://www.holtek.com.tw>.