

PROPRIETARY NOTE

THIS SPECIFICATION IS THE PROPERTY OF HEI AND SHALL NOT BE REPRODUCED OR COPIED WITHOUT THE WRITTEN PERMISSION OF HEI AND MUST BE RETURNED TO HEI UPON ITS REQUEST

HT17E11-100

Preliminary Product Specification

Rev. P1

SPEC. NUMBER
S864-1052

PRODUCT GROUP
TFT_LCD PRODUCT

REV.
P1

ISSUE DATE
2001:05:23

PAGE
1 OF 22

**PRODUCT GROUP****REV.****ISSUE DATE**

TFT-LCD PRODUCT

P1

2001/05/23

REVISION HISTORY

REV.	ECN NO.	DESCRIPTION OF CHANGES	DATE	PREPARED
P0		Initial Release		K.C.CHO
P1		1.View angle (page 7.) New: Right: 75,Left: 75, Up: 70,Down: 60 Old: Right: 80,Left: 80 Up: 55,Down: 60 2.Contrast Ratio (page 7.) New: 400:1 (typ.) Old: 300:1 (typ.) 3. Lamp Current (page 6.) New: 6.0mA (typ.) Old: 6.5mA (typ.) 4. Power Consumption (page 6) New: 24.2 Watt (typ.) Old: 22.6 Watt (typ.) 5. Reliability Test (page 17. Table 6.) 1) Shock test (Non Operation) New: Gravity 70G Old: Gravity 50G 6. Reproduction of Color (page 7.) New: $x_W : 0.316$, $y_W : 0.325$ $x_R : 0.630$, $y_R : 0.356$ $x_G : 0.295$, $y_G : 0.553$ $x_B : 0.142$, $y_B : 0.094$ Old: TBD	2001/5/23	K.C.CHO
SPEC. NUMBER S864-1052		SPEC. TITLE HT17E11-100 Preliminary Product Specification		PAGE 2 OF 22

**PRODUCT GROUP****REV.****ISSUE DATE**

TFT-LCD PRODUCT

P1

2001/05/23

Contents

No.	Item	Page
1.0	General Description	4
2.0	Absolute Maximum Ratings	5
3.0	Electrical Specifications	6
4.0	Optical Specifications	7
5.0	Interface Connection	9
6.0	Signal Timing Specifications	11
7.0	Signal Timing Waveforms of interface signal (DE mode)	13
8.0	Input Signals, Display Colors & Gray Scale of Colors	14
9.0	Power Sequence	15
10.0	Mechanical Characteristics	16
11.0	Reliability Test	17
12.0	Handling & Cautions	18
13.0	Appendix	19

SPEC. NUMBER

S864-1052

SPEC. TITLE

HT17E11-100 Preliminary Product Specification

PAGE

3 OF 22

1.0 GENERAL DESCRIPTION

1.1 Introduction

[HT17E11-100] is a color active matrix TFT LCD module using amorphous silicon TFT's (Thin Film Transistors) as an active switching devices. This module has a 17.0 inch diagonally measured active area with SXGA resolutions (1280 horizontal by 1024 vertical pixel array). Each pixel is divided into RED, GREEN, BLUE dots which are arranged in vertical stripe and this module can display 16,777,216 colors. The TFT-LCD panel used for this module is adapted for a low reflection and higher color type.

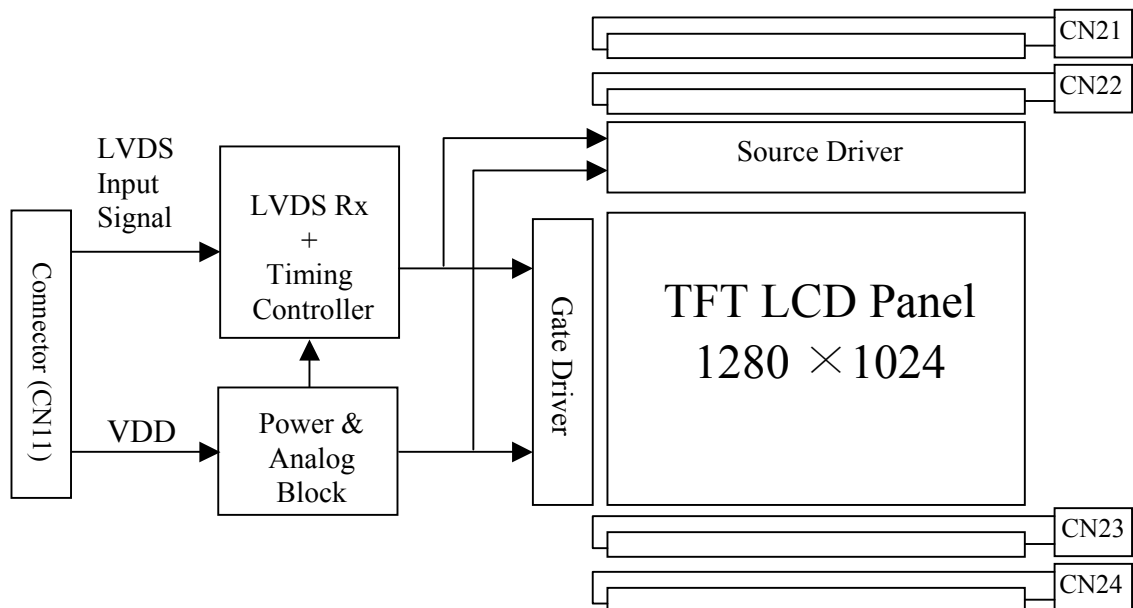

1.2 Features

- LVDS Interface with 2 pixel / clock
- High-speed response
- Low power consumption
- 8-bit color depth, display 16,777,216 colors
- Incorporated edge type back-light (Four lamps)
- High luminance and contrast ratio, low reflection and wide viewing angle
- DE (Data Enable) mode only

1.3 Applications

- Desktop Type of PC & Workstation Use
- Slim-Size Display for Stand-alone Monitor
- Display Terminals for Control System
- Monitors for Process Controller

**PRODUCT GROUP****REV.****ISSUE DATE**

TFT-LCD PRODUCT

P1

2001/05/23

1.4 General Specifications

The followings are general specifications at the model [HT17E11-100].

<Table 1. General Specifications>

Parameter	Specification	Unit	Remarks
Active area	337.92 (H) × 270.336(V)	mm	
Number of pixels	1280(H) × 1024(V)	pixels	
Pixel pitch	0.264(H) × 0.264(V)	mm	
Pixel arrangement	RGB Vertical stripe		
Display colors	16,777,216	colors	
Display mode	Normally White		
Dimensional outline	383.5(H) × 306.5(V) × 22.8(D) typ.	mm	
Weight	2,200 typ.	gram	
Back-light	Top/Bottom edge side 4-CCFL type		Note 1

Note: 1. CCFL (Cold Cathode Fluorescent Lamp)

2.0 ABSOLUTE MAXIMUM RATINGS

The followings are maximum values which, if exceed, may cause faulty operation or damage to the unit. The operational and non-operational maximum voltage and current values are listed in Table 2.

<Table 2. Absolute Maximum Ratings>

[VSS = GND =0V]

Parameter	Symbol	Min	Max	Unit	Remarks
Power Input Voltage	V _{DD}	VSS-0.5	6.5	V	Ta = 25°C
Logic Input Voltage	V _{IN}	VSS-0.3	V _{DD} +0.3	V	
Back-light Lamp Current	I _{BL}	3	7	mA	
Back-light lamp Frequency	F _L	40	(80)	KHz	
Operating Temperature (Humidity)	T _{OP}	0	+50	°C	≤ 40 °C
	RH		80	%	
Storage Temperature (Humidity)	T _{ST}	-20	+60	°C	≤ 40 °C
	RH		90	%	

SPEC. NUMBER

S864-1052

SPEC. TITLE

HT17E11-100 Preliminary Product Specification

PAGE

5 OF 22

3.0 ELECTRICAL SPECIFICATIONS

< Table 3. Electrical specifications >

[Ta = 25±2°C]

Parameter		Min	Typ	Max	Unit	Remarks
Power Supply Voltage	V _{DD}	4.5	5.0	5.5	V	Note1
Power Supply Current	I _{DD}	-	680	1000	mA	
Permissible Input Ripple Voltage	V _{RF}			100	mV	V _{DD} = 5.0V
High Level Differential Input Threshold Voltage	V _{IH}		-	+100	V	V _{cm} = 1.2V typ.
Low Level Differential Input Threshold Voltage	V _{IL}	-100	-		V	
Back-light Lamp Voltage	V _{BL}	-	800	-	V _{rms}	
Back-light Lamp Current	I _{BL}	3.0	6.0	7.0	mA _{rms}	
Back-light Lamp operating Frequency	F _L	40	-	60	KHz	Note 2
Lamp Start Voltage				1075	V _{rms}	25°C, Note 3
				1500	V _{rms}	0°C, Note 3
Lamp Life		40000	50000		hrs	I _{BL} = 6.0mA
Power Consumption		P _D	3.4		W	
		P _{BL}	19.2		W	I _{BL} = 6.0mA, Note 4
		P _{total}	22.6		W	

Notes:

- The supply voltage is measured and specified at the interface connector of LCM.
The current draw and power consumption specified is for V_{DD} = 5.0V, Frame rate= 60Hz and Clock frequency = 54MHz. Test Pattern of power supply current
a) Typ: Vertical color bar pattern
b) Max: Vertical 2 Skip lines pattern
- The lamp frequency should be selected as different as possible from the horizontal synchronous frequency and its harmonics to avoid interference, which may cause line flow on the display
- The voltage above this value should be applied to the lamps for more than 1 second to start-up. Otherwise the lamps may not be turned on.
- Calculated value for reference (V_{BL} × I_{BL}) × 4 excluding inverter loss.

4.0 OPTICAL SPECIFICATIONS

4.1 Overview

The test of Optical specifications shall be measured in a dark room (ambient luminance ≤ 1 lux and temperature = $25 \pm 2^\circ\text{C}$) with the equipment of Luminance meter system (Goniometer system and TOPCONE BM-5) and test unit shall be located at an approximate distance 50cm from the LCD surface at a viewing angle of θ and ϕ equal to 0° . We refer to $\theta_{\phi=0}$ ($=\theta_3$) as the 3 o'clock direction (the "right"), $\theta_{\phi=90}$ ($=\theta_{12}$) as the 12 o'clock direction ("upward"), $\theta_{\phi=180}$ ($=\theta_9$) as the 9 o'clock direction ("left") and $\theta_{\phi=270}$ ($=\theta_6$) as the 6 o'clock direction ("bottom"). While scanning θ and/or ϕ , the center of the measuring spot on the display surface shall stay fixed. The measurement shall be executed after 30 minutes warm-up period. VDD shall be 5.0V +/- 10% at 25°C . Optimum viewing angle direction is 6 o'clock.

4.2 Optical Specifications

[VDD=5.0V, Frame rate=60Hz, Clock=54MHz, $I_{BL} = 6.5\text{mA}$, $T_a = 25 \pm 2^\circ\text{C}$]

Parameter		Symbol	Condition	Min	Typ	Max	Unit	Remark
Viewing Angle	Horizontal	Θ_3	CR > 10		75		Deg	Note 1
		Θ_9			75		Deg	
	Vertical	Θ_{12}			70		Deg	
		Θ_6			60		Deg	
Luminance contrast ratio		CR		400				Note 2
Luminance of white		Y_L			250		cd/m^2	Note 3
White luminance uniformity		ΔY				1.18		Note 4
Reproduction of color	White	x_W	$\Theta = 0^\circ$ (Center) Normal Viewing Angle		0.316			Note 5
		y_W			0.325			
	Red	x_R			0.630			
		y_R			0.356			
	Green	x_G			0.295			
		y_G			0.553			
	Blue	x_B			0.142			
		y_B			0.094			
Response time (Rise + Decay)		T_{total}			25		msec	Note 6
Cross talk		CT				2.0	%	Note 7

**PRODUCT GROUP****REV.****ISSUE DATE**

TFT-LCD PRODUCT

P1

2001/05/23

Note:

1. Viewing angle is the angle at which the contrast ratio is greater than 10. The viewing are determined for the horizontal or 3, 9 o'clock direction and the vertical or 6, 12 o'clock direction with respect to the optical axis which is normal to the LCD surface (See FIGURE 1 shown in Appendix).
2. Contrast measurements shall be made at viewing angle of $\theta = 0^\circ$ and at the center of the LCD surface. Luminance shall be measured with all pixels in the view field set first to white, then to the dark (black) state. (See FIGURE 1 shown in Appendix) Luminance Contrast Ratio (CR) is defined mathematically.

$$CR = \frac{\text{Luminance when displaying a white raster}}{\text{Luminance when displaying a black raster}}$$

3. Center Luminance of white is defined as the LCD surface. Luminance shall be measured with all pixels in the view field set first to white. This measurement shall be taken at the locations shown in FIGURE 2 for a total of the measurements per display.
4. The White luminance uniformity on LCD surface is then expressed as : $\Delta Y = \text{Maximum Luminance of five points} / \text{Minimum Luminance of five points}$ (See FIGURE 2 shown in Appendix).
5. The color chromaticity coordinates specified in Table 4. shall be calculated from the spectral data measured with all pixels first in red, green, blue and white. Measurements shall be made at the center of the panel.
6. The electro-optical response time measurements shall be made as FIGURE 3 shown in Appendix by switching the "data" input signal ON and OFF. The times needed for the luminance to change from 10% to 90% is Td, and 90% to 10% is Tr.
7. Cross-Talk of one area of the LCD surface by another shall be measured by comparing the luminance (Y_A) of a 25mm diameter area, with all display pixels set to a gray level, to the luminance (Y_B) of that same area when any adjacent area is driven dark. (See FIGURE 4 shown in Appendix).

SPEC. NUMBER

S864-1052

SPEC. TITLE

HT17E11-100 Preliminary Product Specification

PAGE

8 OF 22

**PRODUCT GROUP****REV.****ISSUE DATE**

TFT-LCD PRODUCT

P1

2001/05/23

5.0 INTERFACE CONNECTION

5.1 Electrical Interface Connection

- CN11: Module Side Connector : FI-X30S-HF (JAE)
User Side Connector : FI-X30H-HF (JAE) or equivalent

Pin No	Symbol	Function	Remark
1	RX00-	LVDS ODD 0 – SIGNAL	
2	RX00+	LVDS ODD 0 + SIGNAL	
3	RX01-	LVDS ODD 1 – SIGNAL	
4	RX01+	LVDS ODD 1 + SIGNAL	
5	RX02-	LVDS ODD 2 – SIGNAL	
6	RX02+	LVDS ODD 2 + SIGNAL	
7	GND	GROUND	
8	RXOCLK-	LVDS ODD CLOCK – SIGNAL	
9	RXOCLK+	LVDS ODD CLCOK + SIGNAL	
10	RX03-	LVDS ODD 3 – SIGNAL	
11	RX03+	LVDS ODD 3 + SIGNAL	
12	RXE0-	LVDS EVEN 0 – SIGNAL	
13	RXE0+	LVDS EVEN 0 + SIGNAL	
14	GND	GROUND	
15	RXE1-	LVDS EVEN 1 – SIGNAL	
16	RXE1+	LVDS EVEN 1 + SIGNAL	
17	GND	GROUND	
18	RXE2-	LVDS EVEN 2 – SIGNAL	
19	RXE2+	LVDS EVEN 2 + SIGNAL	
20	RXECLK-	LVDS EVEN CLOCK – SIGNAL	
21	RXECLK+	LVDS EVEN CLOCK + SIGNAL	
22	RXE3-	LVDS EVEN 3 – SIGNAL	
23	RXE3+	LVDS EVEN 3 + SIGNAL	
24	GND	GROUND	
25	NC	NO CONECTION	
26	DE	DE OUT	
27	NC	NO CONECTION	
28	VDD	POWER SUPPLY (+5.0V)	
29	VDD		
30	VDD		

5.2 LVDS Interface (Tx : THC63LVDM83A or Equivalent)

SPEC. NUMBER

S864-1052

SPEC. TITLE

HT17E11-100 Preliminary Product Specification

PAGE

9 OF 22



PRODUCT GROUP

REV.

ISSUE DATE

TFT-LCD PRODUCT

P1

2001/05/23

	Input signal	Transmitter		Interface		FI-X30S-HF	Remark			
		Pin No	Pin No	System (Tx)	TFT-LCD (Rx)	Pin No.				
O D D L V D S	OR0	51	48 47	OUT0- OUT0+	RXO0- RXO0+	1				
	OR1	52				2				
	OR2	54								
	OR3	55								
	OR4	56								
	OR5	3								
	OG0	4	46 45	OUT1- OUT1+	RXO1- RXO1+	3				
	OG1	6				4				
	OG2	7								
	OG3	11								
	OG4	12								
	OG5	14								
	OB0	15	42 41	OUT2- OUT2+	RXO2- RXO 2+	5				
	OB1	19				6				
	OB2	20								
	OB3	22								
	OB4	23								
	OB5	24								
	HSYNC	27	40 39	CLKOUT- CLKOUT+	RXO CLK- RXO CLK+	8				
	VSYNC	28				9				
DE	30									
MCLK	31									
OR6	50	38 37				OUT3+ OUT3-		RXO 3- RXO 3+	10	
OR7	2								11	
OG6	8									
OG7	10									
OB6	16									
OB7	18									
RSVD	25									
E V E N L V D S	ER0	51	48 47	OUT0- OUT0+	RXE0- RXE 0+	12				
	ER1	52				13				
	ER2	54								
	ER3	55								
	ER4	56								
	ER5	3								
	EG0	4	46 45	OUT1- OUT1+	RXE 1- RXE 1+	15				
	EG1	6				16				
	EG2	7								
	EG3	11								
	EG4	12								
	EG5	14								
	EB0	15	42 41	OUT2- OUT2+	RXE 2- RXE 2+	18				
	EB1	19				19				
	EB2	20								
	EB3	22								
	EB4	23								
	EB5	24								
	HSYNC	27	40 39	CLKOUT- CLKOUT+	RXE CLK- RXE CLK+	20				
	VSYNC	28				21				
DE	30									
MCLK	31									
ER6	50	38 37				OUT3+ OUT3-		RXE 3- RXE 3+	22	
ER7	2								23	
EG6	8									
EG7	10									
EB6	16									
EB7	18									
RSVD	25									

5.3 Data Input Format

ODD EVEN

SPEC. NUMBER

S864-1052

SPEC. TITLE

HT17E11-100 Preliminary Product Specification

PAGE

10 OF 22

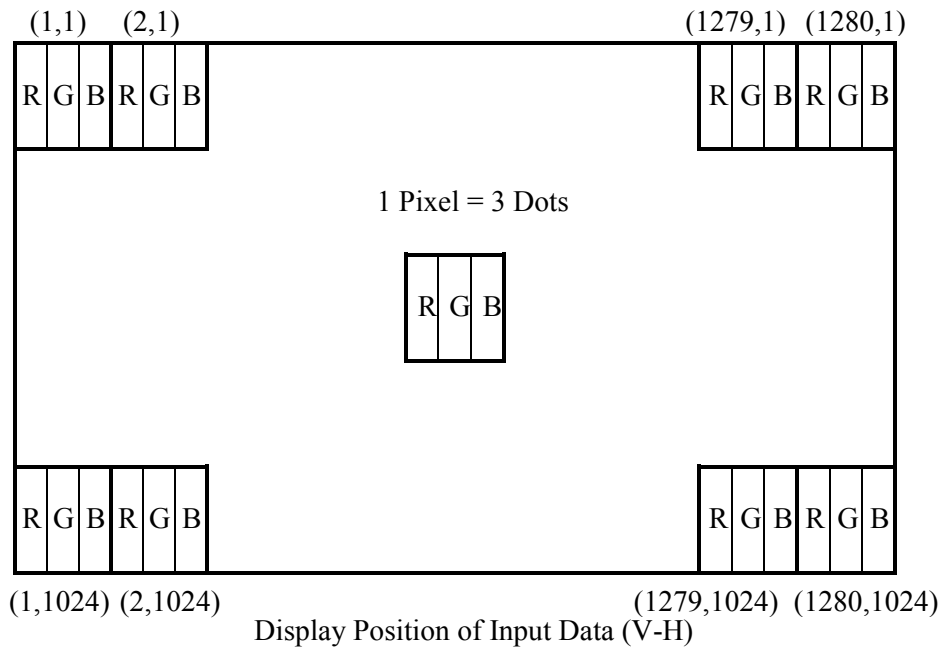

5.4 Back-light Interface Connection

- CN21, 22, 23, 24: Module side connector : BHSR-02VS-1 (JST)
 User side connector : SM02B-BHSS-1-TB (JST) or equivalent

Pin No	INPUT	Color	Function
1	HOT	Pink	High voltage
2	COLD	White	Ground

6.0 SIGNAL TIMING SPECIFICATIONS

6.1 The [HT17E11-100] is operated by the only DE (Data enable) mode (LVDS Transmitter Input)

Item	Symbols	Min	Typ	Max	Unit	
Clock	Frequency	1/Tc	-	54	68	MHz
	High Time	Tch	5	-	-	ns
	Low Time	Tcl	5	-	-	ns
Data	Setup Time	Tds	4	-	-	ns
	Hold Time	Tdh	4	-	-	ns
Data Enable Setup Time	Tes	4	-	-	ns	
Frame Period	Tv	1032	1066	1066	lines	
Vertical Display Period	Tvd	1024	1024	1024	lines	
One Line Scanning Period	Th	672	844	1022	clocks	
Horizontal Display Period	Thd	640	640	640	clocks	

6.2 LVDS Rx interface timing parameter

The specification of the LVDS Rx interface timing parameter is shown in Table 4.

SPEC. NUMBER
SPEC. TITLE
PAGE

S864-1052

HT17E11-100 Preliminary Product Specification

11 OF 22

< Table 4. LVDS Rx Interface Timing Specification >

Item	Symbol	Min	Typ	Max	Unit	Remark
CLKIN Period	tRCIP	14.7	18.5	-	nsec	
CLK Difference	tCdiff	TBD	0	TBD	nsec	
Input Data 0	tRIP1	-0.2	0	+0.2	nsec	
Input Data 1	tRIP0	1*tRIPC/7-0.2	1*tRIPC/7	1*tRIPC/7+0.2	nsec	
Input Data 2	tRIP6	2*tRIPC/7-0.2	2*tRIPC/7	2*tRIPC/7+0.2	nsec	
Input Data 3	tRIP5	3*tRIPC/7-0.2	3*tRIPC/7	3*tRIPC/7+0.2	nsec	
Input Data 4	tRIP4	4*tRIPC/7-0.2	4*tRIPC/7	4*tRIPC/7+0.2	nsec	
Input Data 5	tRIP3	5*tRIPC/7-0.2	5*tRIPC/7	5*tRIPC/7+0.2	nsec	
Input Data 6	tRIP2	6*tRIPC/7-0.2	6*tRIPC/7	6*tRIPC/7+0.2	nsec	

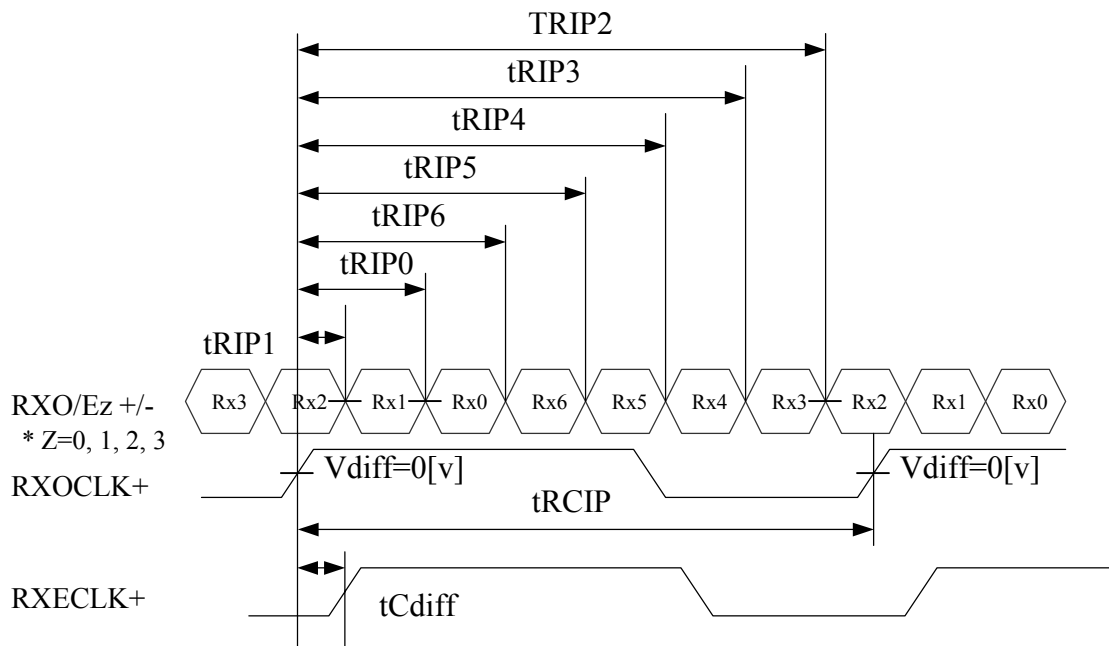

* $V_{diff} = (RXO/Ez+) - (RXO/Ez-), \dots, (RXO/ECLK+) - (RXO/ECLK-)$

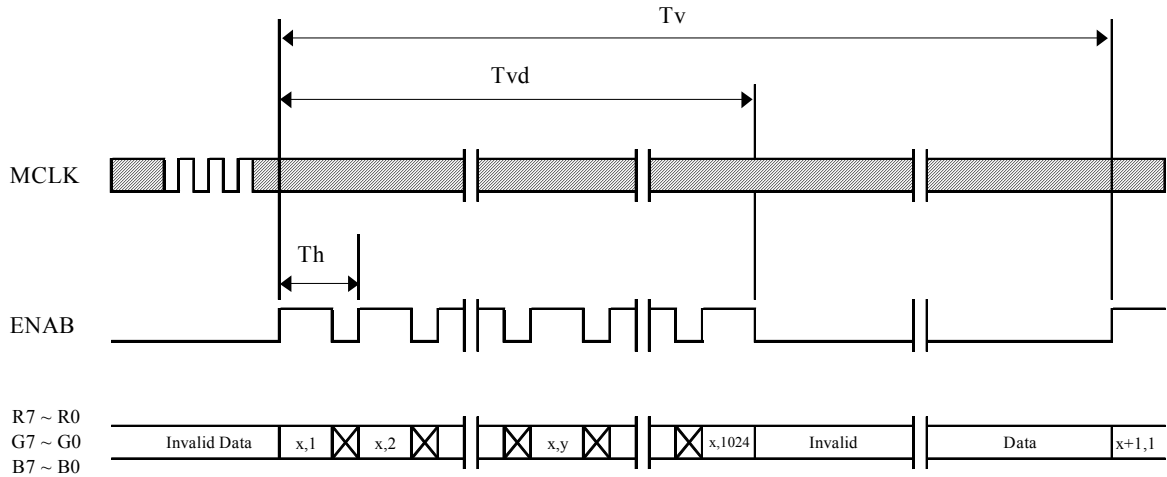
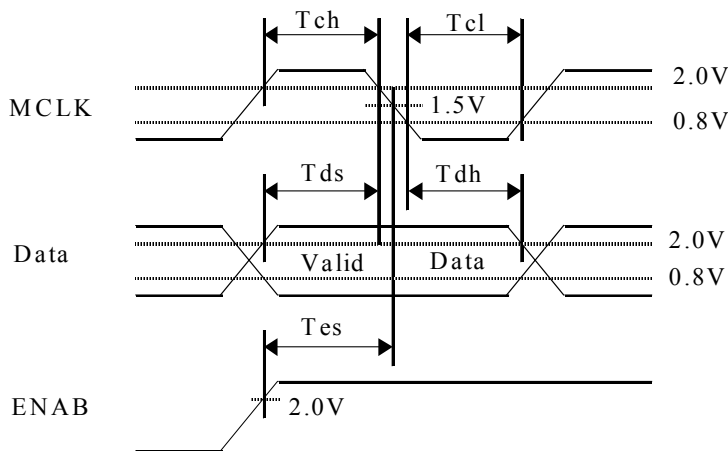
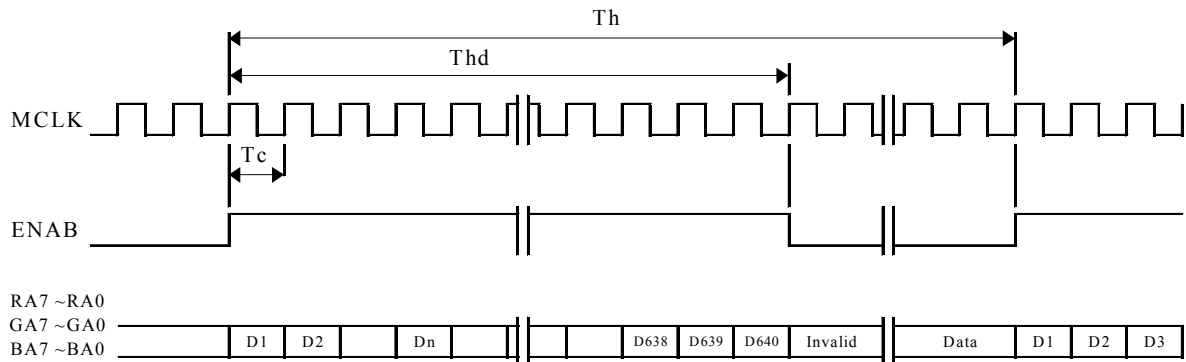
7.0 SIGNAL TIMING WAVEFORMS OF INTERFACE SIGNAL (DE MODE)
7.1 Vertical Timing Waveforms

7.2 Horizontal Timing Waveforms



PRODUCT GROUP

REV.

ISSUE DATE

TFT-LCD PRODUCT

P1

2001/05/23

8.0 INPUT SIGNALS, BASIC DISPLAY COLORS & GRAY SCALE OF COLORS

Colors & Gray Scale		Red data								Green data								Blue data							
		R7	R6	R5	R4	R3	R2	R1	R0	G7	G6	G5	G4	G3	G2	G1	G0	B7	B6	B5	B4	B3	B2	B1	B0
Basic Colors	Black	0	0	0	0	0	0	0	0	0	0	0	0	0	0	0	0	0	0	0	0	0	0	0	0
	Blue	0	0	0	0	0	0	0	0	0	0	0	0	0	0	0	0	1	1	1	1	1	1	1	1
	Green	0	0	0	0	0	0	0	0	1	1	1	1	1	1	1	1	0	0	0	0	0	0	0	0
	Cyan	0	0	0	0	0	0	0	0	1	1	1	1	1	1	1	1	1	1	1	1	1	1	1	1
	Red	1	1	1	1	1	1	1	1	0	0	0	0	0	0	0	0	0	0	0	0	0	0	0	0
	Magenta	1	1	1	1	1	1	1	1	0	0	0	0	0	0	0	0	0	0	1	1	1	1	1	1
	Yellow	1	1	1	1	1	1	1	1	1	1	1	1	1	1	1	1	0	0	0	0	0	0	0	0
	White	1	1	1	1	1	1	1	1	1	1	1	1	1	1	1	1	1	1	1	1	1	1	1	1
Gray Scale Of Red	Black	0	0	0	0	0	0	0	0	0	0	0	0	0	0	0	0	0	0	0	0	0	0	0	0
	△	0	0	0	0	0	0	1	0	0	0	0	0	0	0	0	0	0	0	0	0	0	0	0	0
	Darker	0	0	0	0	0	0	1	0	0	0	0	0	0	0	0	0	0	0	0	0	0	0	0	0
	△	↓								↓								↓							
	▽	↓								↓								↓							
	Brighter	1	1	1	1	1	1	0	1	0	0	0	0	0	0	0	0	0	0	0	0	0	0	0	0
	▽	1	1	1	1	1	1	0	0	0	0	0	0	0	0	0	0	0	0	0	0	0	0	0	0
	Red	1	1	1	1	1	1	1	1	0	0	0	0	0	0	0	0	0	0	0	0	0	0	0	0
Gray Scale Of Green	Black	0	0	0	0	0	0	0	0	0	0	0	0	0	0	0	0	0	0	0	0	0	0	0	0
	△	0	0	0	0	0	0	0	0	0	0	0	0	0	0	0	1	0	0	0	0	0	0	0	0
	Darker	0	0	0	0	0	0	0	0	0	0	0	0	0	0	1	0	0	0	0	0	0	0	0	0
	△	↓								↓								↓							
	▽	↓								↓								↓							
	Brighter	0	0	0	0	0	0	0	0	1	1	1	1	1	1	0	1	0	0	0	0	0	0	0	0
	▽	0	0	0	0	0	0	0	0	1	1	1	1	1	1	0	0	0	0	0	0	0	0	0	0
	Green	0	0	0	0	0	0	0	0	1	1	1	1	1	1	1	1	0	0	0	0	0	0	0	0
Gray Scale Of Blue	Black	0	0	0	0	0	0	0	0	0	0	0	0	0	0	0	0	0	0	0	0	0	0	0	0
	△	0	0	0	0	0	0	0	0	0	0	0	0	0	0	0	0	0	0	0	0	0	0	0	1
	Darker	0	0	0	0	0	0	0	0	0	0	0	0	0	0	0	0	0	0	0	0	0	0	1	0
	△	↓								↓								↓							
	▽	↓								↓								↓							
	Brighter	0	0	0	0	0	0	0	0	0	0	0	0	0	0	0	0	1	1	1	1	1	1	0	1
	▽	0	0	0	0	0	0	0	0	0	0	0	0	0	0	0	0	1	1	1	1	1	1	1	0
	Blue	0	0	0	0	0	0	0	0	0	0	0	0	0	0	0	0	1	1	1	1	1	1	1	1
Gray Scale Of White & Black	Black	0	0	0	0	0	0	0	0	0	0	0	0	0	0	0	0	0	0	0	0	0	0	0	0
	△	0	0	0	0	0	0	1	0	0	0	0	0	0	0	1	0	0	0	0	0	0	0	0	1
	Darker	0	0	0	0	0	0	1	0	0	0	0	0	0	0	1	0	0	0	0	0	0	0	1	0
	△	↓								↓								↓							
	▽	↓								↓								↓							
	Brighter	1	1	1	1	1	1	0	1	1	1	1	1	1	1	0	1	1	1	1	1	1	1	0	1
	▽	1	1	1	1	1	1	0	0	1	1	1	1	1	1	0	1	1	1	1	1	1	1	1	0
	White	1	1	1	1	1	1	1	1	1	1	1	1	1	1	1	1	1	1	1	1	1	1	1	1

SPEC. NUMBER

S864-1052

SPEC. TITLE

HT17E11-100 Preliminary Product Specification

PAGE

14 OF 22

9.0 POWER SEQUENCE

To prevent a latch-up or DC operation of the LCD module, the power on/off sequence should be as shown in below

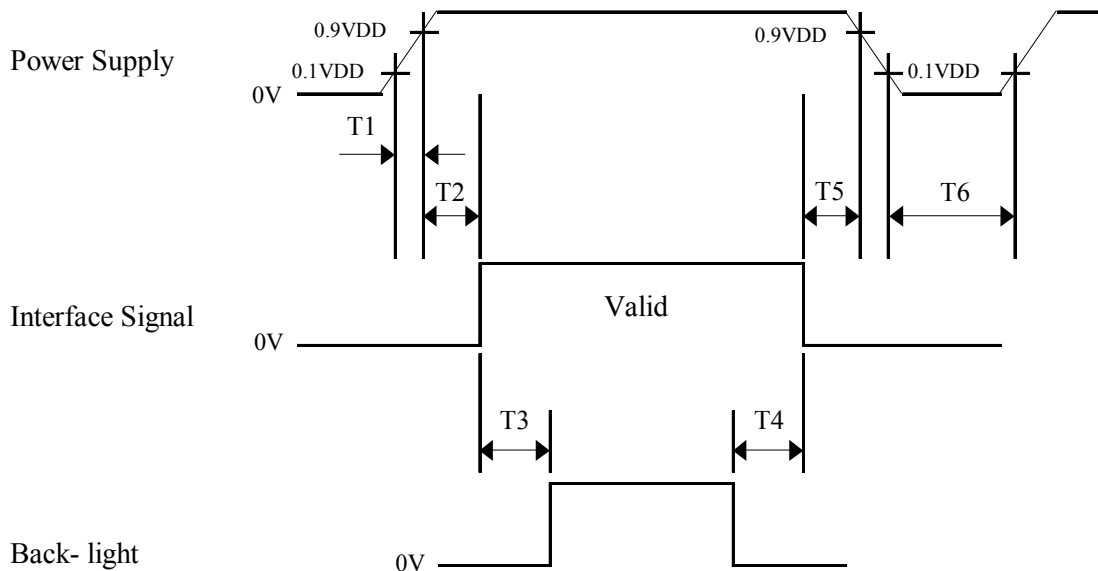

- $0 < T1 \leq 10 \text{ ms}$
- $0 < T2 \leq 50 \text{ ms}$
- $500 \text{ ms} \leq T3$
- $100 \leq T4$
- $0 < T5 \leq 50 \text{ ms}$
- $1 \text{ sec} \leq T6$

Notes:

1. When the power supply VDD is 0V, Keep the level of input signals on the low or keep high impedance.
2. Do not keep the interface signal high impedance when power is on.
3. Back Light must be turn on after power for logic and interface signal are valid.

10.0 MECHANICAL CHARACTERISTICS

10.1 Dimensional Requirements

FIGURE 6 shown in appendix shows mechanical outlines for the model [HT17E11-100]. Other parameters are shown in Table 5.

<Table 5. Dimensional Parameters>

Parameter	Specification	Unit
Active area	337.92 (H) × 270.336(V)	mm
Number of pixels	1280(H) × 1024(V)	pixels
	(1 pixel = R + G + B dot)	
Pixel pitch	0.264(H) × 0.264(V)	mm
Pixel arrangement	RGB Vertical stripe	
Display colors	16,777,216	colors
Display mode	Normally white	
Dimensional outline	383.5 (H) × 306.5 (V) × 22.8 (D)	mm
Weight	2,200 typ.	gram
Back-light	Top / Bottom edge side 4-CCFL type	

10.2 Mounting

See FIGURE 5 shown in appendix

10.3 Anti-Glare and Polarizer Hardness.

The surface of the LCD has an anti-glare coating to minimize reflection and a coating to reduce scratching.

10.4 Light Leakage

There shall not be visible light from the back-lighting system around the edges of the screen as seen from a distance 50[cm] from the screen with an overhead light level of 350[lux].

The manufacture shall furnish limit samples of the panel showing the lightest leakage acceptable.

11.0 RELIABILITY TEST

The Reliability test items and its conditions are shown in below.

<Table 6. Reliability Test Parameters>

No	Test Items	Conditions
1	High temperature storage test	Ta = 60 °C, 240 hrs
2	Low temperature storage test	Ta = -20 °C, 240 hrs
3	High temperature & high humidity operation test	Ta = 50 °C, 80 %RH, 240 hrs
4	High temperature operation test	Ta = 50 °C, 240 hrs
5	Low temperature operation test	Ta = 0 °C, 240 hrs
6	Thermal shock	Ta = 0 °C ↔ 50 °C (30 min), 100 cycle
7	Vibration test (non-operating)	Frequency : 10 ~ 300 Hz, Sweep rate 10min Gravity/AMP : 1.5G Period : ±X, ±Y, ±Z 30min
8	Shock test (non-operating)	Gravity : 70G Pulse width : 11ms, sine wave ±X, ±Y, ±Z Once for each direction
9	Electrostatic discharge test	Air : 150 pF, 330Ω , 15KV Contact : 150 pF, 330Ω , 8KV

**PRODUCT GROUP****REV.****ISSUE DATE**

TFT-LCD PRODUCT

P1

2001/05/23

12.0 HANDLING & CAUTIONS

12.1 Cautions when taking out the module

- Pick the pouch only, when taking out module from a shipping package.

12.2 Cautions for handling the module

- As the electrostatic discharges may break the LCD module, handle the LCD module with care. Peel a protection sheet off from the LCD panel surface as slowly as possible.
- As the LCD panel and back-light element are made from fragile glass material, impulse and pressure to the LCD module should be avoided.
- As the surface of the polarizer is very soft and easily scratched, use a soft dry-cloth without chemicals for cleaning.
- Do not pull the interface connector in or out while the LCD module is operating.
- Put the module display side down on a flat horizontal plane.
- Handle connectors and cables with care.

12.3 Cautions for the operation

- When the module is operating, do not lose LVDS signals. If any one of these signals were lost, the LCD panel would be damaged.
- Obey the supply voltage sequence. If the wrong sequences were applied, the module would be damaged.

12.4 Cautions for the atmosphere

- Dewdrop atmosphere should be avoided.
- Do not store and/or operate the LCD module in a high temperature and/or humidity atmosphere. Storage in an electro-conductive polymer-packing pouch and under relatively low temperature atmosphere is recommended.

12.5 Cautions for the module characteristics

- Do not apply fixed pattern data signal to the LCD module at aging time.
- Applying fixed pattern for a long time may cause image sticking.

12.6 Other cautions

- Do not disassemble and/or re-assemble LCD module.
- Do not re-adjust variable resistor or switch etc.
- When returning the module for repair or etc, please pack the module not to be broken. We recommend on using the original shipping packages.

SPEC. NUMBER

S864-1052

SPEC. TITLE

HT17E11-100 Preliminary Product Specification

PAGE

18 OF 22

13.0 APPENDIX

Figure 1. Measurement Set Up

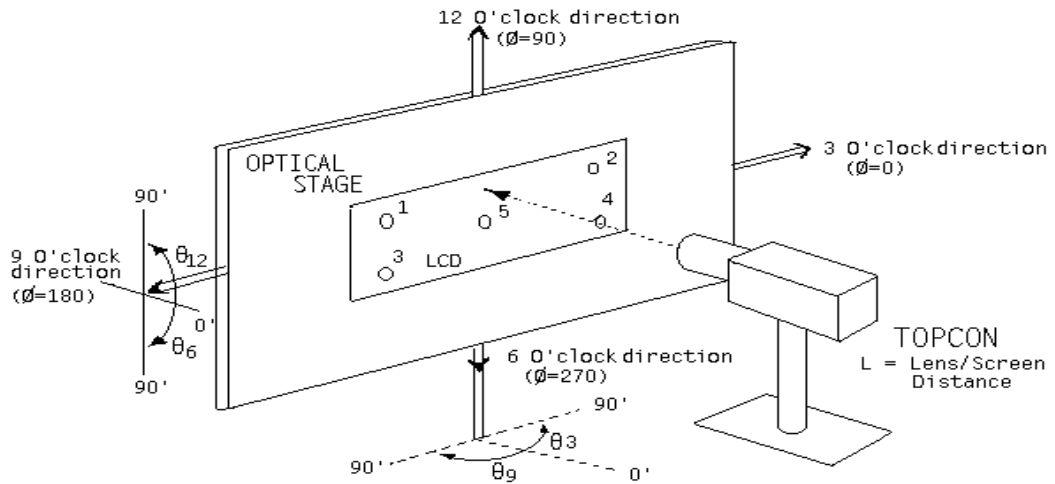

Figure 2. Average Luminance Measurement Locations & Uniformity Measurement Locations

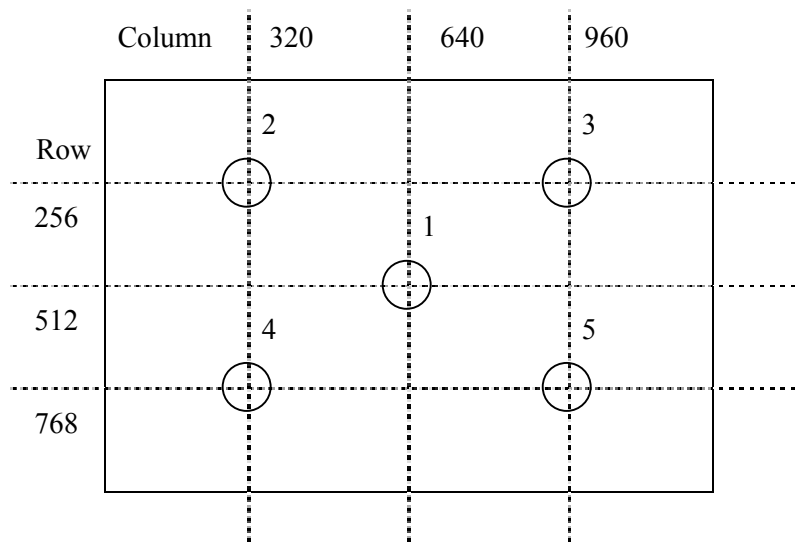
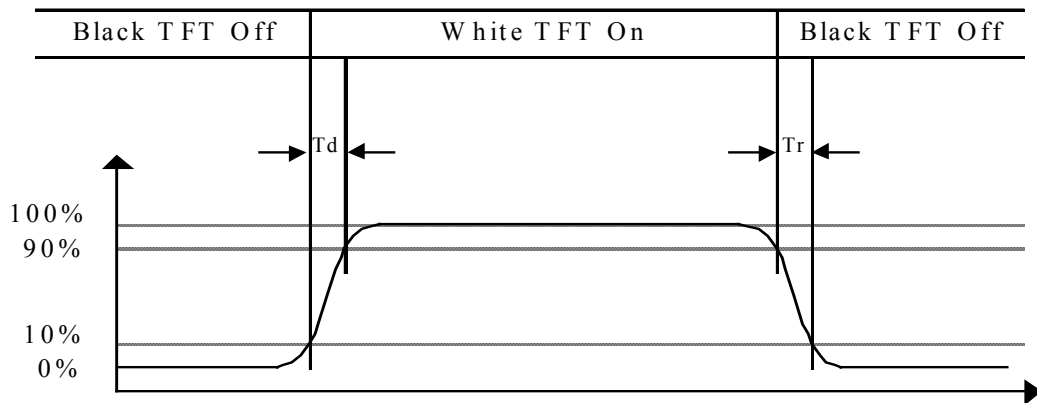
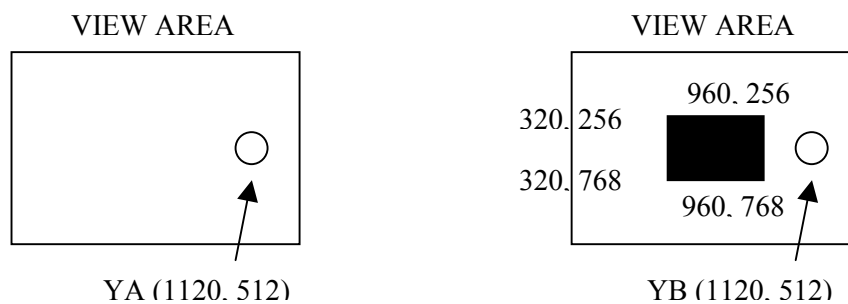

Figure 3. Response Time Testing

Figure 4. Cross Modulation Test Description

$$\text{Cross-Talk} = \left| \frac{Y_B - Y_A}{Y_A} \right| \times 100$$

Where:

Y_A = Initial luminance of measured area (cd/m^2)

Y_B = Subsequent luminance of measured area (cd/m^2)

The location measured will be exactly the same in both patterns.

Figure 5. TFT-LCD Module Outline Dimensions (Front view)

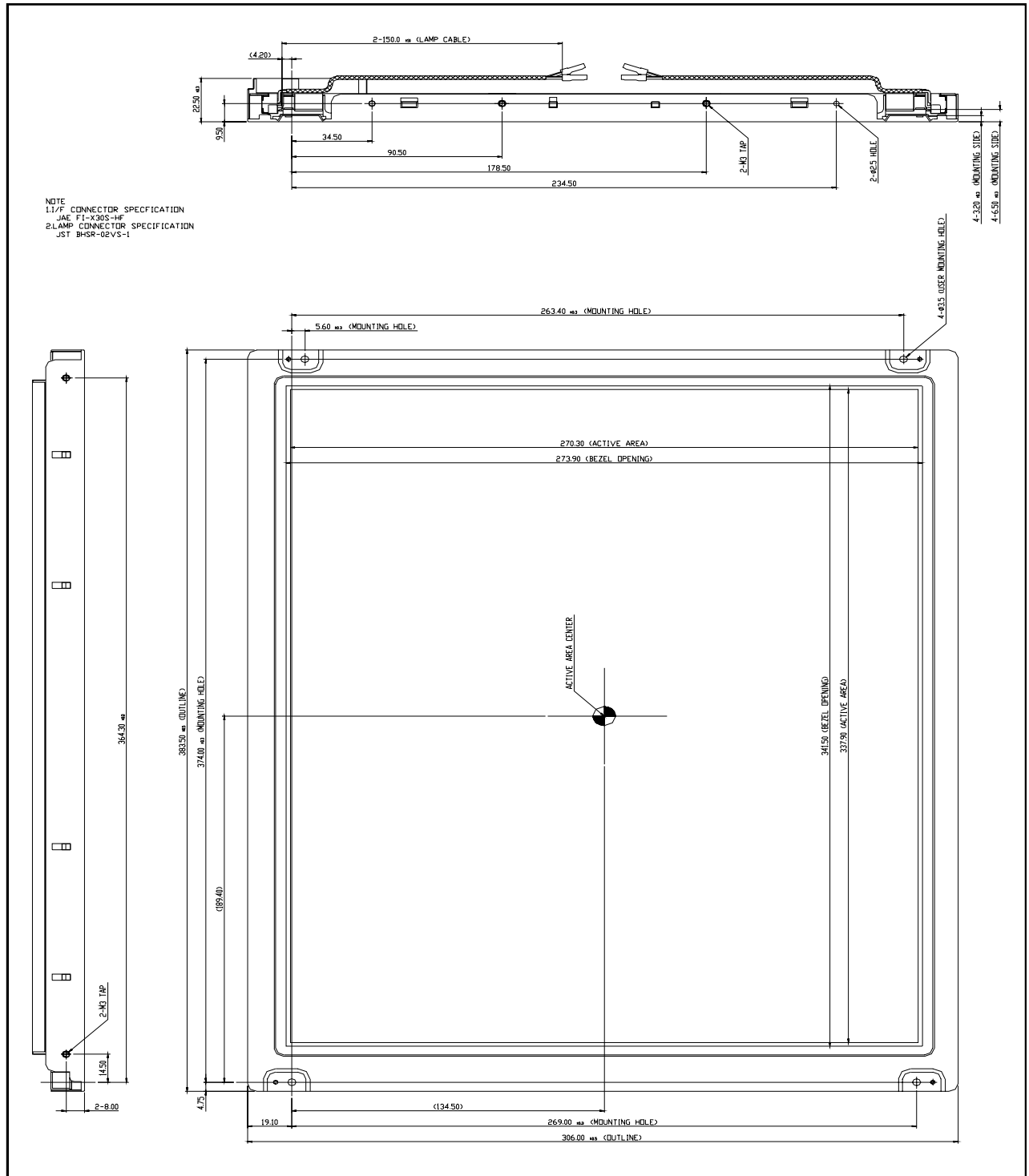

SPEC. NUMBER

S864-1052

SPEC. TITLE

HT17E11-100 Preliminary Product Specification

PAGE

21 OF 22

