



PROPRIETARY NOTE

THIS SPECIFICATION IS THE PROPERTY OF BOE OT AND SHALL NOT BE REPRODUCED OR COPIED WITHOUT THE WRITTEN PERMISSION OF BOE OT AND MUST BE RETURNED TO BOE OT UPON ITS REQUEST

TITLE : HT190WG1-602

Product Specification

Rev. 0

www.jxlcd.com

BEIJING BOE OPTOELECTRONICS TECHNOLOGY

SPEC. NUMBER	PRODUCT GROUP	REV.	ISSUE DATE	PAGE
S865-5001	TFT-LCD	0	2010.09.30	1 OF 29



PRODUCT GROUP

REV

ISSUE DATE

TFT- LCD PRODUCT

0

2010.09.30

REVISION HISTORY

REV.	ECN No.	DESCRIPTION OF CHANGES	DATE	PREPARED
0		Initial Release	2010.09.30'	Hu Ming
SPEC. NUMBER S865-5001	SPEC. TITLE HT190WG1-602 Product Specification			PAGE 2 OF 29

www.jxlcd.com



京东方
BOE

PRODUCT GROUP

REV

ISSUE DATE

TFT- LCD PRODUCT

0

2010.09.30

Contents

No.	Item	Page
1.0	General Description	4
2.0	Absolute Maximum Ratings	6
3.0	Electrical specifications	7
4.0	Optical specifications	8
5.0	Interface Connection	10
6.0	Signal Timing Specifications	14
7.0	Signal Timing waveforms of Interface Signal	16
8.0	Input Signals, Display Colors & Gray Scale of Colors	18
9.0	Power Sequence	19
10.0	Mechanical Characteristics	20
11.0	Reliability Test	21
12.0	Handling & Cautions	22
13.0	Product Serial Number	23
14.0	Packing	24
15.0	Appendix	26

SPEC. NUMBER

S865-5001

SPEC. TITLE

HT190WG1-602 Product Specification

PAGE

3 OF 29

1.0 General Description

1.1 Introduction

HT190WG1-602 is a color active matrix TFT LCD module using amorphous silicon TFT's (Thin Film Transistors) as an active switching devices. This module has a 19.0 inch diagonally measured active area with WXGA+ resolutions (1440 horizontal by 900 vertical pixel array). Each pixel is divided into RED, GREEN, BLUE dots which are arranged in vertical stripe and this module can display 16,7 M colors. The TFT-LCD panel used for this module is adapted for a low reflection and higher color type.

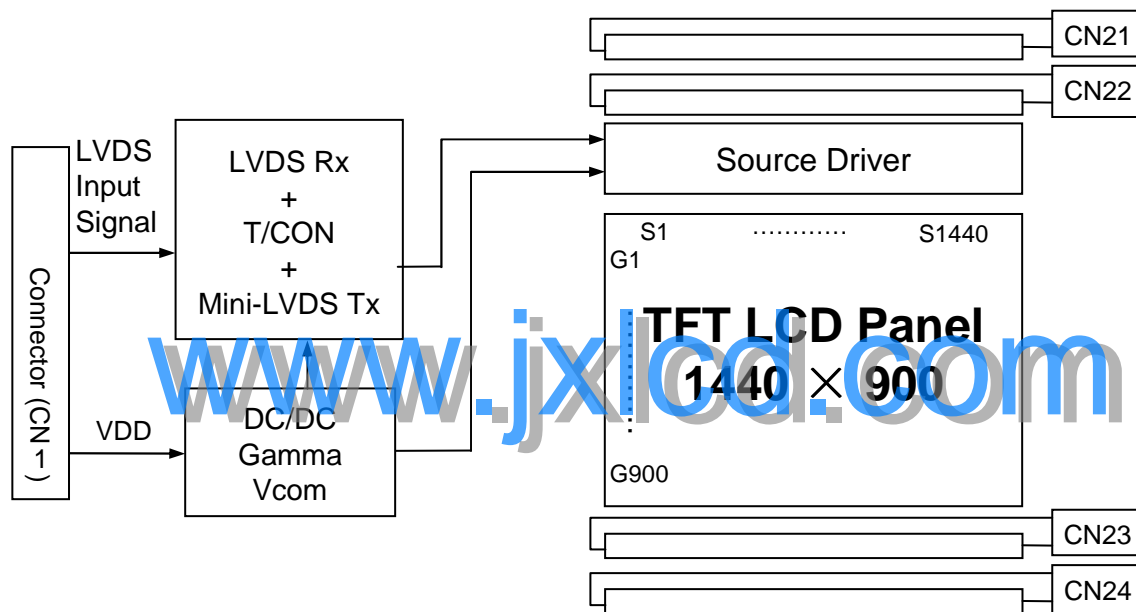

1.2 Features

- LVDS Interface with 2 pixel / clock
- High-speed response
- Low power consumption
- 6-bit (Hi-FRC) color depth, display 16,7 M colors
- Incorporated edge type back-light (Four lamps)
- High luminance and contrast ratio, low reflection and wide viewing angle
- DE (Data Enable) only
- RoHS Compliance
- TCO03 Compliance



PRODUCT GROUP

REV

ISSUE DATE

TFT- LCD PRODUCT

0

2010.09.30

1.3 Application

- Desktop Type of PC & Workstation Use
- Slim-Size Display for Stand-alone Monitor
- Display Terminals for Control System
- Monitors for Process Controller

1.4 General Specification

The followings are general specifications at the model HT190WG1-602.

<Table 1. General Specifications>

Parameter	Specification	Unit	Remarks
Active area	408.24(H) × 255.15(V)	mm	
Number of pixels	1440(H) × 900(V)	pixels	
Pixel pitch	0.2835(H) × 0.2835(V)	mm	
Pixel arrangement	RGB Vertical stripe		
Display colors	16.7M	colors	
Display mode	Normally White		
Dimensional outline	428.0(H) × 278.0(V) × 17.0 (D) typ.	mm	± 0.5mm
Weight	2000 (max.)	g	
Surface Treatment	Haze 25%, 3H		
Back-light	Top/Bottom edge side, 4-CCFL type		

SPEC. NUMBER
S865-5001

SPEC. TITLE
HT190WG1-602 Product Specification

PAGE
5 OF 29

2.0 ABSOLUTE MAXIMUM RATINGS

The followings are maximum values which, if exceed, may cause faulty operation or damage to the unit. The operational and non-operational maximum voltage and current values are listed in Table 2.

< Table 2. Absolute Maximum Ratings >

[VSS=GND=0V]

Parameter	Symbol	Min.	Max.	Unit	Remarks
Power Supply Voltage	V_{DD}	VSS-0.5	6.5	V	Ta = 25 °C
Logic Supply Voltage	V_{IN}	VSS-0.3	$V_{DD}+0.3$	V	
Back-light Lamp Current	I_{BL}	3	8	mA	
Back-light Lamp frequency	F_L	30	80	kHz	
Operating Temperature	T_{OP}	0	+50	°C	Note 1
Storage Temperature	T_{ST}	-20	+60	°C	Note 1

Note : 1) Temperature and relative humidity range are shown in the figure below.

Wet bulb temperature should be 39 °C max. and no condensation of water.

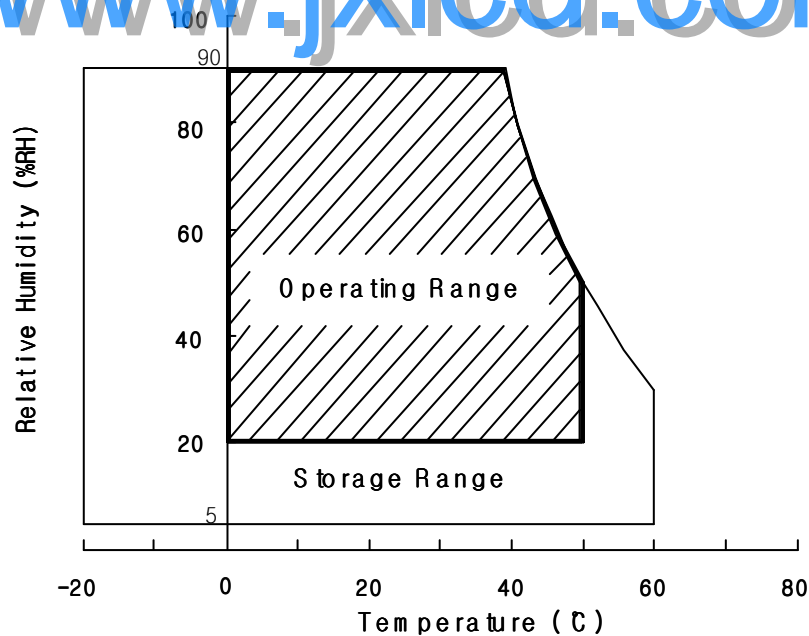

3.0 ELECTRICAL SPECIFICATIONS

3.1 Electrical Specifications

< Table 3. Electrical specifications >

[Ta =25 ± 2 °C]

Parameter		Min.	Typ.	Max.	Unit	Remarks
Power Supply Voltage	V _{DD}	4.5	5.0	5.5	V	Note1
Power Supply Current	I _{DD}	-	800	1100	mA	
In-Rush Current	I _{RUSH}	-	2.0	3.0	A	Note 2
Permissible Input Ripple Voltage	V _{RF}	-	-	100	mV	V _{DD} = 5.0V
High Level Differential Input Threshold Voltage	V _{IH}	-	-	+100	mV	V _{cm} = 1.2V typ.
Low Level Differential Input Threshold Voltage	V _{IL}	-100	-	-	mV	
Back-light Lamp Voltage	V _{BL}	-	740	-	V _{rms}	
Back-light Lamp Current	I _{BL}	3.0	6.5	8.0	mA _{rms}	
Back-light Lamp operating Frequency	F _L	45	-	60	KHz	Note 3
Lamp Start Voltage		-	-	1400	V _{rms}	25 °C, Note 4
		-	-	1700	V _{rms}	0 °C, Note 4
Lamp Life		40,000	50,000	-	Hrs	I _{BL} = 6.5 mA
Power Consumption	P _D	-	4.0		W	
	P _{BL}	-	19.24		W	I _{BL} = 6.5mA, Note 5
	P _{total}	-	23.24		W	

Notes : 1. The supply voltage is measured and specified at the interface connector of LCM.
 The current draw and power consumption specified is for VDD=5.0V, Frame rate=76Hz and
 Clock frequency =56.3MHz. Test Pattern of power supply current

- a) Typ : Color Bar pattern
 b) Max : Dot pattern

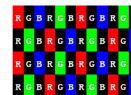

2. Duration of rush current is about 2 ms and rising time of VDD is 520 μs ± 20 %
 3. The lamp frequency should be selected as different as possible from the horizontal synchronous frequency and its harmonics to avoid interference, which may cause line flow on the display
 4. The voltage above this value should be applied to the lamps for more than 1 second to start-up. Otherwise the lamps may not be turned on.
 5. Calculated value for reference (V_{BL} × I_{BL}) × 4 excluding inverter loss.



PRODUCT GROUP

REV

ISSUE DATE

TFT- LCD PRODUCT

0

2010.09.30

4.0 OPTICAL SPECIFICATION

4.1 Overview

The test of Optical specifications shall be measured in a dark room (ambient luminance ≤ 1 lux and temperature = $25 \pm 2^\circ\text{C}$) with the equipment of Luminance meter system (Goniometer system and TOPCONE BM-5) and test unit shall be located at an approximate distance 50cm from the LCD surface at a viewing angle of Θ and Φ equal to 0° . We refer to $\Theta_{\theta=0}$ ($=\Theta_3$) as the 3 o'clock direction (the "right"), $\Theta_{\theta=90}$ ($=\Theta_{12}$) as the 12 o'clock direction ("upward"), $\Theta_{\theta=180}$ ($=\Theta_9$) as the 9 o'clock direction ("left") and $\Theta_{\theta=270}$ ($=\Theta_6$) as the 6 o'clock direction ("bottom"). While scanning Θ and/or Φ , the center of the measuring spot on the Display surface shall stay fixed. The measurement shall be executed after 30 minutes warm-up period. VDD shall be 5.0V +/-10% at 25°C . Optimum viewing angle direction is 6 'clock.

4.2 Optical Specifications

[VDD = 5.0V, Frame rate = 60Hz, Clock = 54MHz, $I_{BL} = 6.5\text{mA}$, $T_a = 25 \pm 2^\circ\text{C}$]

Parameter		Symbol	Condition	Min.	Typ.	Max.	Unit	Remark
Viewing Angle range	Horizontal	Θ_3	CR > 10	70	85	-	Deg.	Note 1
		Θ_9		70	85	-	Deg.	
	Vertical	Θ_{12}		70	80	-	Deg.	
		Θ_6		70	80	-	Deg.	
Viewing Angle range	Horizontal	Θ_3	CR > 5	85	-	-	Deg.	
		Θ_9		85	-	-	Deg.	
	Vertical	Θ_{12}		85	-	-	Deg.	
		Θ_6		85	-	-	Deg.	
Luminance Contrast ratio		CR	$\Theta = 0^\circ$ (Center) Normal Viewing Angle	700	1000			Note 2
Luminance of White		Y_w		270	300		cd/m^2	Note 3
White luminance uniformity		ΔY		75	80		%	Note 4
Reproduction of color	White	W_x		0.283	0.313	0.343		Note 5
		W_y	0.299	0.329	0.359			
	Red	R_x	0.610	0.640	0.670			
		R_y	0.306	0.336	0.366			
	Green	G_x	0.249	0.279	0.309			
		G_y	0.573	0.603	0.633			
	Blue	B_x	0.110	0.140	0.171			
		B_y	0.038	0.068	0.098			
Response Time	Rising	T_r	$T_a = 25^\circ\text{C}$ $\Theta = 0^\circ$		1.5	2.5	ms	Note 6
	Falling	T_f			3.5	5.5	ms	
Cross Talk		CT			-	-	2.0	%

SPEC. NUMBER

S865-5001

SPEC. TITLE

HT190WG1-602 Product Specification

PAGE

8 OF 29



PRODUCT GROUP

REV

ISSUE DATE

TFT- LCD PRODUCT

0

2010.09.30

Note :

1. Viewing angle is the angle at which the contrast ratio is greater than 10. The viewing are determined for the horizontal or 3, 9 o'clock direction and the vertical or 6, 12 o'clock direction with respect to the optical axis which is normal to the LCD surface.
2. Contrast measurements shall be made at viewing angle of $\theta=0^\circ$ and at the center of the LCD surface. Luminance shall be measured with all pixels in the view field set first to white, then to the dark (black) state. (See FIGURE 1 shown in Appendix) Luminance Contrast Ratio (CR) is defined mathematically.

$$CR = \frac{\text{Luminance when displaying a white raster}}{\text{Luminance when displaying a black raster}}$$

3. Center Luminance of white is defined as the LCD surface. Luminance shall be measured with all pixels in the view field set first to white. This measurement shall be taken at the locations shown in FIGURE 2 for a total of the measurements per display.
4. The White luminance uniformity on LCD surface is then expressed as :
 $\Delta Y = (\text{Minimum Luminance of 9points} / \text{Maximum Luminance of 9points}) * 100$
 (See FIGURE 2 shown in Appendix).
5. The color chromaticity coordinates specified in Table 4. shall be calculated from the spectral data measured with all pixels first in red, green, blue and white. Measurements shall be made at the center of the panel.
6. The electro-optical response time measurements shall be made as FIGURE 3 shown in Appendix by switching the "data" input signal ON and OFF. The times needed for the luminance to change from 10% to 90% is Td, and 90% to 10% is Tr.
7. Cross-Talk of one area of the LCD surface by another shall be measured by comparing the luminance (Y_A) of a 25mm diameter area, with all display pixels set to a gray level, to the luminance (Y_B) of that same area when any adjacent area is driven dark. (See FIGURE 4 shown in Appendix).

SPEC. NUMBER S865-5001	SPEC. TITLE HT190WG1-602 Product Specification	PAGE 9 OF 29
---------------------------	---	-----------------

5.0 INTERFACE CONNECTION.

5.1 Electrical Interface Connection

- CN11 Module Side Connector : UJU IS100-L300-C23 or Equivalent
User Side Connector : JAE FI-X30H or Equivalent

Pin No	Symbol	Function	Remark
1	RXO0-	Negative Transmission data of Pixel 0 (ODD)	
2	RXO0+	Positive Transmission data of Pixel 0 (ODD)	
3	RXO1-	Negative Transmission data of Pixel 1 (ODD)	
4	RXO1+	Positive Transmission data of Pixel 1 (ODD)	
5	RXO2-	Negative Transmission data of Pixel 2 (ODD)	
6	RXO2+	Positive Transmission data of Pixel 2 (ODD)	
7	GND	Power Ground	
8	RXOC-	Negative Transmission Clock (ODD)	
9	RXOC+	Positive Transmission Clock (ODD)	
10	RXO3-	Negative Transmission data of Pixel 3 (ODD)	
11	RXO3+	Positive Transmission data of Pixel 3 (ODD)	
12	RXE0-	Negative Transmission data of Pixel 0 (EVEN)	
13	RXE0+	Positive Transmission data of Pixel 0 (EVEN)	
14	GND	Power Ground	
15	RXE1-	Negative Transmission data of Pixel 1 (EVEN)	
16	RXE1+	Positive Transmission data of Pixel 1 (EVEN)	
17	GNG	Power Ground	
18	RXE2-	Negative Transmission data of Pixel 2 (EVEN)	
19	RXE2+	Positive Transmission data of Pixel 2 (EVEN)	
20	RXEC-	Negative Transmission Clock (EVEN)	
21	RXEC+	Positive Transmission Clock (EVEN)	
22	RXE3-	Negative Transmission data of Pixel 3 (EVEN)	
23	RXE3+	Positive Transmission data of Pixel 3 (EVEN)	
24	GND	Power Ground	Note 1
25	(CE)	LCD internal use only	Internal Use
26	(CTL)		Internal Use
27	NC	No. Connection	
28	VDD	Power Supply: +5V	
29	VDD		
30	VDD		

Note 1 : This pin should be connected with GND.



PRODUCT GROUP

REV

ISSUE DATE

TFT- LCD PRODUCT

0

2010.09.30

5.2 LVDS Interface (Tx; THC63LVDF83A or Equivalent)

5.2.1 ODD LVDS Interface

	Input Signal	Transmitter		Interface		HT190WG1-602 (CN11)	Remark
		Pin No.	Pin No.	System (Tx)	TFT-LCD (Rx)	Pin No.	
O D D L V D S	OR0	51	48 47	OUT0- OUT0+	RX00- RX00+	1 2	
	OR1	52					
	OR2	54					
	OR3	55					
	OR4	56					
	OR5	3					
	OG0	4	46 45	OUT1- OUT1+	RX01- RX01+	3 4	
	OG1	6					
	OG2	7					
	OG3	11					
	OG4	12					
	OG5	14					
	OB0	15	42 41	OUT2- OUT2+	RX02- RX02+	5 6	
	OB1	19					
	OB2	20					
	OB3	22					
	OB4	23					
	OB5	24					
	Hsync	27	40 39	CLK OUT- CLK OUT+	RXO CLK- RXO CLK+	8 9	
	Vsync	28					
	DE	30					
	MCLK	31	38 37	OUT3- OUT3+	RX03- RX03+	10 11	
	OR6	50					
	OR7	2					
	OG6	8					
OG7	10						
OB6	16						
OB7	18						
RSVD	25						

SPEC. NUMBER

S865-5001

SPEC. TITLE

HT190WG1-602 Product Specification

PAGE

11 OF 29



PRODUCT GROUP

REV

ISSUE DATE

TFT- LCD PRODUCT

0

2010.09.30

5.2.2 EVEN LVDS Interface

	Input Signal	Transmitter		Interface		HT190WG1-602 (CN11)	Remark
		Pin No.	Pin No.	System (Tx)	TFT-LCD (Rx)	Pin No.	
E V E N L V D S	ER0	51	48 47	OUT0- OUT0+	RX00- RX00+	12 13	
	ER1	52					
	ER2	54					
	ER3	55					
	ER4	56					
	ER5	3					
	EG0	4	46 45	OUT1- OUT1+	RX01- RX01+	15 16	
	EG1	6					
	EG2	7					
	EG3	11					
	EG4	12					
	EG5	14					
	EB0	15	42 41	OUT2- OUT2+	RX02- RX02+	18 19	
	EB1	19					
	EB2	20					
	EB3	22					
	EB4	23					
	EB5	24					
	Hsync	27	40 39	CLK OUT- CLK OUT+	RX0 CLK- RX0 CLK+	20 21	
	Vsync	28					
	DE	30					
	MCLK	31	38 37	OUT3- OUT3+	RX03- RX03+	22 23	
	ER6	50					
	ER7	2					
	EG6	8					
	EG7	10					
	EB6	16					
	EB7	18					
RSVD	25						

SPEC. NUMBER

S865-5001

SPEC. TITLE

HT190WG1-602 Product Specification

PAGE

12 OF 29

5.3 Data Input Format

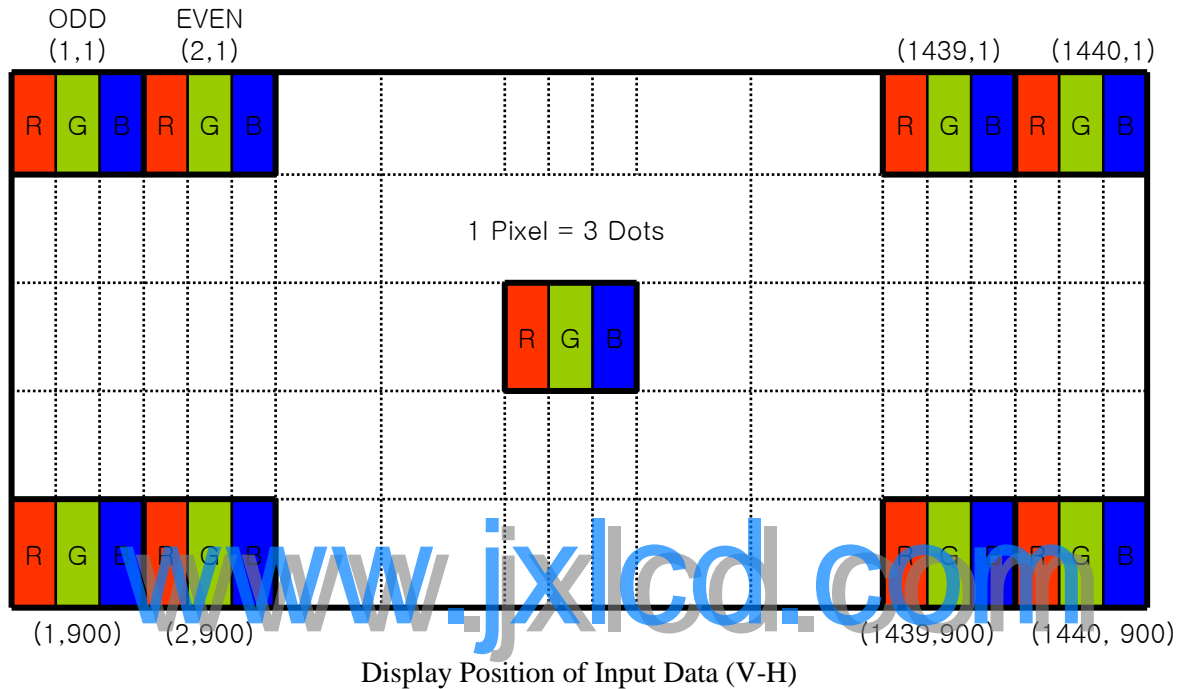

5.4 Back-light Interface Connection

- CN 21,22,23,24 Module Side Connector :35001HS-02L(YeonHo) or Equivalent
- User Side Connector :35001WR-02L(YeonHo) or Equivalent

PIN NO.	INPUT	COLOR	FUNCTION
1	HOT	Pink & Blue	High Voltage
2	COLD	Black & White	Ground



PRODUCT GROUP

REV

ISSUE DATE

TFT- LCD PRODUCT

0

2010.09.30

6.0 SIGNAL TIMING SPECIFICATION

6.1 The HT190WG1-602 is operated by the DE only..

Item		Symbols	Min	Typ	Max	Unit
Clock	Frequency	1/Tc	41.5	44.5	65.7	MHz
	High Time	Tch	4	-	-	ns
	Low Time	Tcl	4	-	-	ns
Data	Setup time	Tds	4	-	-	ns
	Hold time	Tdh	4	-	-	ns
Data Enable Setup Time		Tes	4	-	-	ns
Frame Period		Tv	918	926	1050	lines
			56	60	76	Hz
			17.9	16.7	13.1	ms
Vertical Display Period		Tvd	-	900	-	lines
One line Scanning Period		Th	760	800	1400	clocks
Horizontal Display Period		Thd	720	720	720	clocks

SPEC. NUMBER
S865-5001

SPEC. TITLE
HT190WG1-602 Product Specification

PAGE
14 OF 29

6.2 LVDS Rx Interface Timing Parameter

The specification of the LVDS Rx interface timing parameter is shown in Table 4.

<Table 4. LVDS Rx Interface Timing Specification>

Item	Symbol	Min	Typ	Max	Unit	Remark
CLKIN Period	tRCIP	14.7	18.5	-	msec	
CLK Difference	tCdiff	-tRCIP*(3/7)	0	+tRCIP*(3/7)	nsec	
Input Data 0	tRIP1	-0.4	0.0	+0.4	nsec	
Input Data 1	tRIP0	tRCIP/7-0.4	tRCIP/7	tRCIP/7+0.4	nsec	
Input Data 2	tRIP6	2 × tRCIP/7-0.4	2 × tRCIP/7	2 × tRCIP/7+0.4	nsec	
Input Data 3	tRIP5	3 × tRCIP/7-0.4	3 × tRCIP/7	3 × tRCIP/7+0.4	nsec	
Input Data 4	tRIP4	4 × tRCIP/7-0.4	4 × tRCIP/7	4 × tRCIP/7+0.4	nsec	
Input Data 5	tRIP3	5 × tRCIP/7-0.4	5 × tRCIP/7	5 × tRCIP/7+0.4	nsec	
Input Data 6	tRIP2	6 × tRCIP/7-0.4	6 × tRCIP/7	6 × tRCIP/7+0.4	nsec	

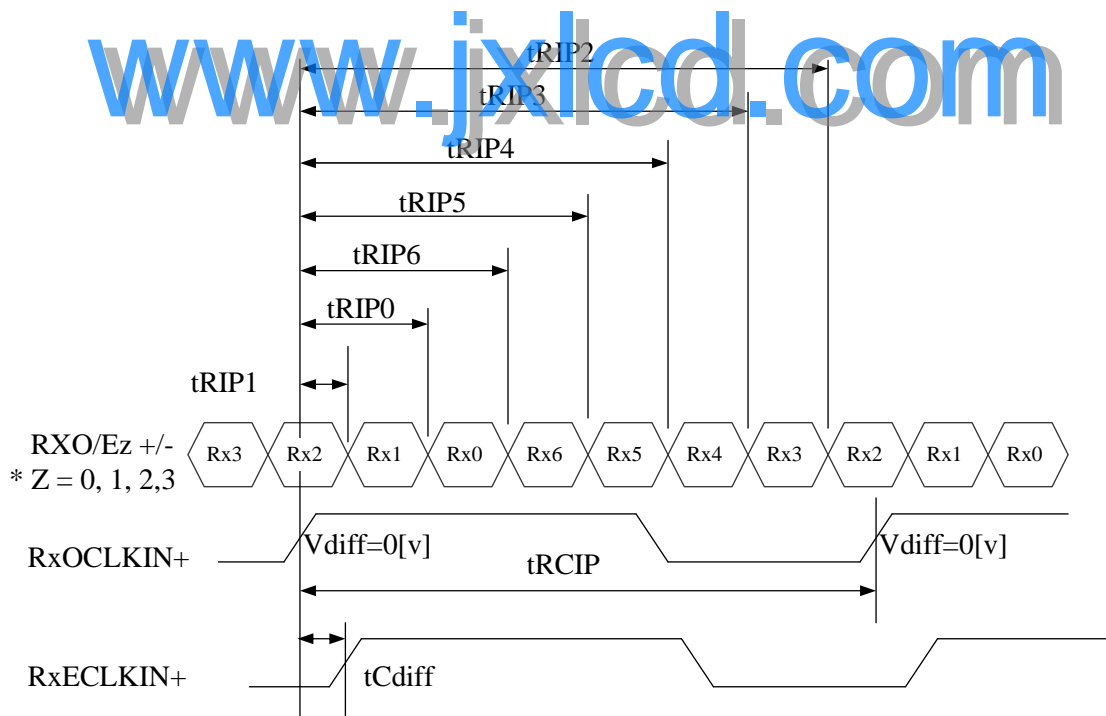

$$* V_{diff} = (RXO/Ez+) - (RXO/Ez-), \dots, (RXO/ECLK+) - (RXO/ECLK-)$$

7.0 SIGNAL TIMING WAVEFORMS OF INTERFACE SIGNAL

7.1 Sync Timing Waveforms

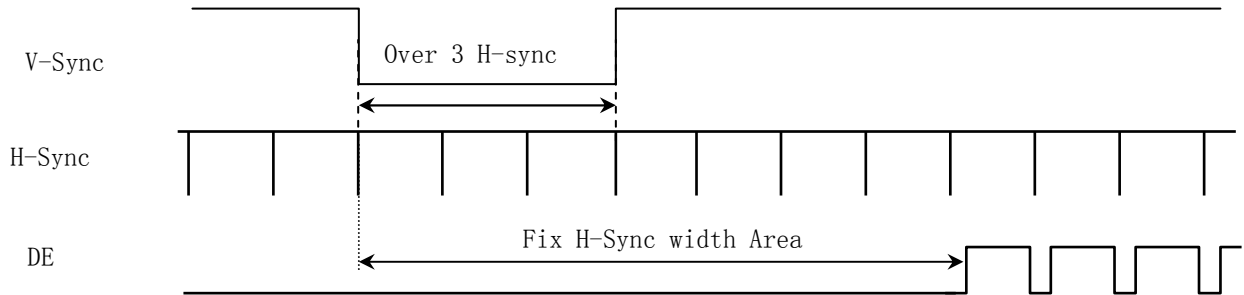

- 1) Need over 3 H-sync during V-Sync Low
- 2) Fix H-Sync width from V-Sync falling edge to first rising edge

7.2 Vertical Timing Waveforms

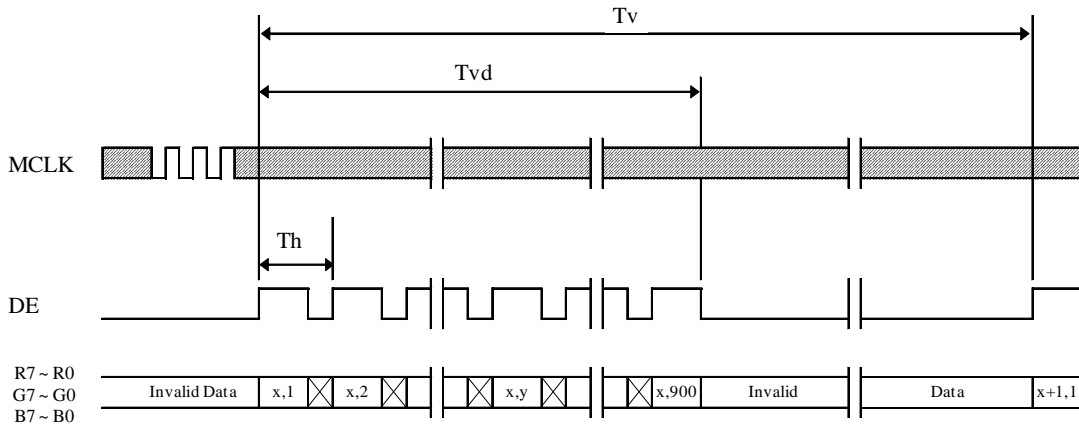

7.3 Horizontal Timing Waveforms

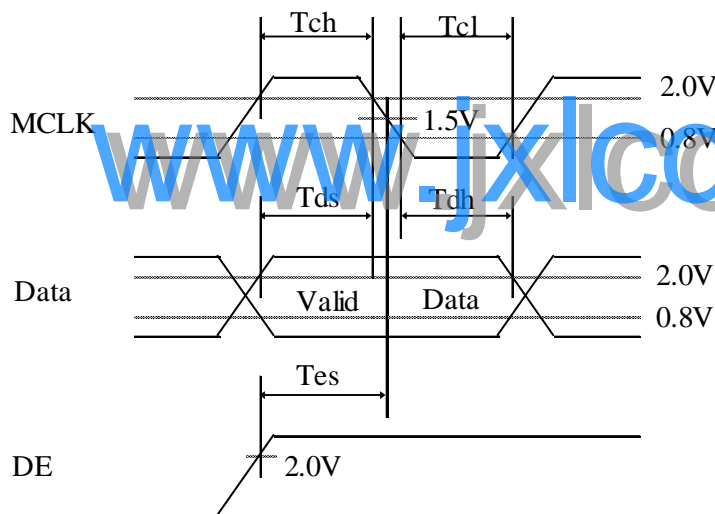
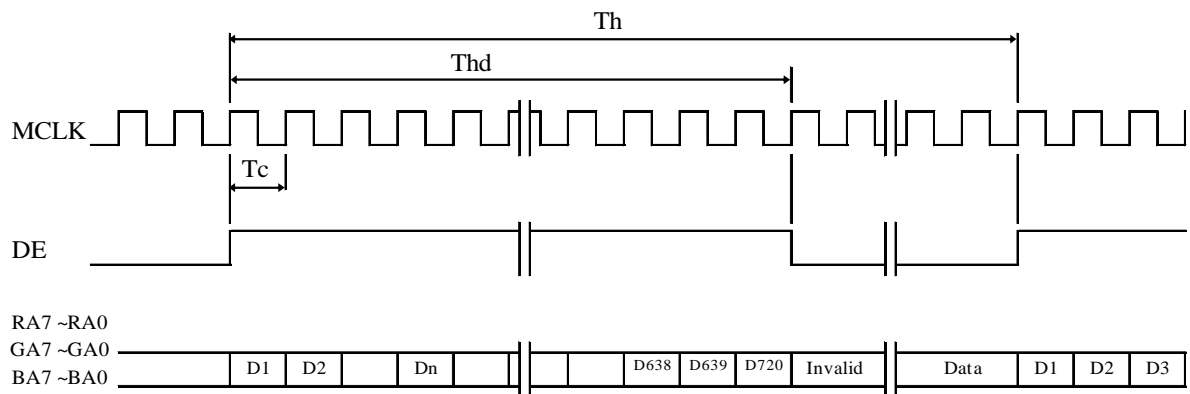



PRODUCT GROUP

REV

ISSUE DATE

TFT- LCD PRODUCT

0

2010.09.30

8.0 INPUT SIGNALS, BASIC DISPLAY COLORS & GRAY SCALE OF COLORS

Color & Gray Scale		RED DATA								GREEN DATA								BLUE DATA							
		R7	R6	R5	R4	R3	R2	R1	R0	G7	G6	G5	G4	G3	G2	G1	G0	B7	B6	B5	B4	B3	B2	B1	B0
Basic Colors	Black	0	0	0	0	0	0	0	0	0	0	0	0	0	0	0	0	0	0	0	0	0	0	0	0
	Blue	0	0	0	0	0	0	0	0	0	0	0	0	0	0	0	0	1	1	1	1	1	1	1	1
	Green	0	0	0	0	0	0	0	0	1	1	1	1	1	1	1	1	0	0	0	0	0	0	0	0
	Cyan	0	0	0	0	0	0	0	0	1	1	1	1	1	1	1	1	1	1	1	1	1	1	1	1
	Red	1	1	1	1	1	1	1	1	0	0	0	0	0	0	0	0	0	0	0	0	0	0	0	0
	Magenta	1	1	1	1	1	1	1	1	0	0	0	0	0	0	0	0	1	1	1	1	1	1	1	1
	Yellow	1	1	1	1	1	1	1	1	1	1	1	1	1	1	1	1	0	0	0	0	0	0	0	0
	White	1	1	1	1	1	1	1	1	1	1	1	1	1	1	1	1	1	1	1	1	1	1	1	1
Gray Scale of RED	Black	0	0	0	0	0	0	0	0	0	0	0	0	0	0	0	0	0	0	0	0	0	0	0	0
	△	0	0	0	0	0	0	1	0	0	0	0	0	0	0	0	0	0	0	0	0	0	0	0	0
	Darker	0	0	0	0	0	0	1	0	0	0	0	0	0	0	0	0	0	0	0	0	0	0	0	0
	△	↑								↑								↑							
	▽	↓								↓								↓							
	Brighter	1	1	1	1	1	1	0	1	0	0	0	0	0	0	0	0	0	0	0	0	0	0	0	0
	▽	1	1	1	1	1	1	0	0	0	0	0	0	0	0	0	0	0	0	0	0	0	0	0	0
	Red	1	1	1	1	1	1	1	1	0	0	0	0	0	0	0	0	0	0	0	0	0	0	0	0
Gray Scale of GREEN	Black	0	0	0	0	0	0	0	0	0	0	0	0	0	0	0	0	0	0	0	0	0	0	0	0
	△	0	0	0	0	0	0	0	0	0	0	0	0	0	0	0	1	0	0	0	0	0	0	0	0
	Darker	0	0	0	0	0	0	0	0	0	0	0	0	0	0	1	0	0	0	0	0	0	0	0	0
	△	↑								↑								↑							
	▽	↓								↓								↓							
	Brighter	0	0	0	0	0	0	0	1	1	1	1	1	1	1	0	1	0	0	0	0	0	0	0	0
	▽	0	0	0	0	0	0	0	1	1	1	1	1	1	1	0	0	0	0	0	0	0	0	0	0
	Green	0	0	0	0	0	0	0	0	1	1	1	1	1	1	1	1	0	0	0	0	0	0	0	0
Gray Scale of BLUE	Black	0	0	0	0	0	0	0	0	0	0	0	0	0	0	0	0	0	0	0	0	0	0	0	0
	△	0	0	0	0	0	0	0	0	0	0	0	0	0	0	0	0	0	0	0	0	0	0	0	1
	Darker	0	0	0	0	0	0	0	0	0	0	0	0	0	0	0	0	0	0	0	0	0	0	1	0
	△	↑								↑								↑							
	▽	↓								↓								↓							
	Brighter	0	0	0	0	0	0	0	0	0	0	0	0	0	0	0	1	1	1	1	1	1	1	0	1
	▽	0	0	0	0	0	0	0	0	0	0	0	0	0	0	0	1	1	1	1	1	1	1	1	0
	Blue	0	0	0	0	0	0	0	0	0	0	0	0	0	0	0	0	1	1	1	1	1	1	1	1
Gray Scale of WHITE	Black	0	0	0	0	0	0	0	0	0	0	0	0	0	0	0	0	0	0	0	0	0	0	0	0
	△	0	0	0	0	0	0	1	0	0	0	0	0	0	0	0	1	0	0	0	0	0	0	0	1
	Darker	0	0	0	0	0	0	1	0	0	0	0	0	0	0	1	0	0	0	0	0	0	0	1	0
	△	↑								↑								↑							
	▽	↓								↓								↓							
	Brighter	1	1	1	1	1	1	0	1	1	1	1	1	1	1	0	1	1	1	1	1	1	1	0	1
	▽	1	1	1	1	1	1	0	0	1	1	1	1	1	1	0	0	1	1	1	1	1	1	1	0
	White	1	1	1	1	1	1	1	1	1	1	1	1	1	1	1	1	1	1	1	1	1	1	1	1

SPEC. NUMBER

S865-5001

SPEC. TITLE

HT190WG1-602 Product Specification

PAGE

18 OF 29

9.0 POWER SEQUENCE

To prevent a latch-up or DC operation of the LCD module, the power on/off sequence shall be as shown in below

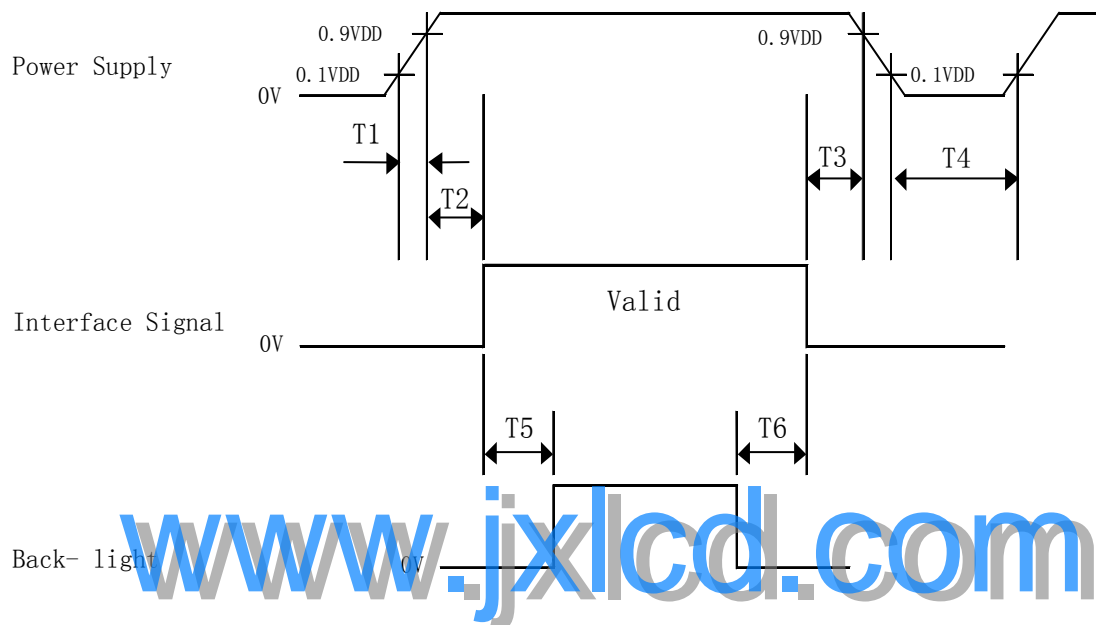

- $0.5 \text{ ms} \leq T1 \leq 10 \text{ ms}$
- $0 \leq T2 \leq 50 \text{ ms}$
- $0 \leq T3 \leq 50 \text{ ms}$
- $1 \text{ sec} \leq T4$
- $200 \text{ ms} \leq T5$
- $200 \text{ ms} \leq T6$

Notes:

1. When the power supply VDD is 0V, Keep the level of input signals on the low or keep high impedance.
2. Do not keep the interface signal high impedance when power is on. Back Light must be turn on after power for logic and interface signal are valid.

10.0 MECHANICAL CHARACTERISTICS

10.1 Dimensional Requirements

FIGURE 6 (located in Appendix) shows mechanical outlines for the model HT190WG1-602. Other parameters are shown in Table 5.

<Table 5. Dimensional Parameters>

Parameter	Specification	Unit
Dimensional outline	428.0 × 278.0 × 17.0 (D) typ.	mm
Weight	2000 (max.)	gram
Active area	408.24(H) × 255.15(V)	mm
Pixel pitch	0.2835(H) × 0.2835(V)	mm
Number of pixels	1440(H) × 900(V) (1 pixel = R + G + B dots)	pixels
Back-light	Top / Bottom edge side 4-CCFL type	

10.2 Mounting

See FIGURE 5. (shown in Appendix)

10.3 Anti-Glare and Polarizer Hardness.

The surface of the LCD has an anti-glare coating to minimize reflection and a coating to reduce scratching.

10.4 Light Leakage

There shall not be visible light from the back-lighting system around the edges of the screen as seen from a distance 50cm from the screen with an overhead light level of 350lux.

11.0 RELIABILITY TEST

The Reliability test items and its conditions are shown in below.

<Table 6. Reliability Test Parameters >

No	Test Items	Conditions
1	High temperature storage test	Ta = 60 °C , 240 hrs
2	Low temperature storage test	Ta = -20 °C , 240 hrs
3	High temperature & high humidity operation test	Ta = 50 °C , 80%RH, 240hrs
4	High temperature operation test	Ta = 50 °C , 240hrs
5	Low temperature operation test	Ta = 0 °C , 240hrs
6	Thermal shock	Ta = -20 °C ↔ 60 °C (0.5 hr), 100 cycle
7	Vibration test (non-operating)	Frequency 10 ~ 300 Hz, Sweep rate 30 min Gravity / AMP 1.5 G Period ± X, ± Y, ± Z 30 min
8	Shock test (non-operating)	Gravity 50G
		Pulse width 11msec, sine wave
		Direction ± X, ± Y, ± Z Once for each
9	Electro-static discharge test (non-operating)	Air : 150 pF, 330 Ω , 15 KV Contact : 150 pF, 330 Ω , 8 KV



京东方
BOE

PRODUCT GROUP

TFT- LCD PRODUCT

REV

0

ISSUE DATE

2010.09.30

12.0 HANDLING & CAUTIONS

- (1) Cautions when taking out the module
 - Pick the pouch only, when taking out module from a shipping package.
- (2) Cautions for handling the module
 - As the electrostatic discharges may break the LCD module, handle the LCD module with care. Peel a protection sheet off from the LCD panel surface as slowly as possible.
 - As the LCD panel and back - light element are made from fragile glass material, impulse and pressure to the LCD module should be avoided.
 - As the surface of the polarizer is very soft and easily scratched, use a soft dry cloth without chemicals for cleaning.
 - Do not pull the interface connector in or out while the LCD module is operating.
 - Put the module display side down on a flat horizontal plane.
 - Handle connectors and cables with care.
- (3) Cautions for the operation
 - When the module is operating, do not lose CLK, ENAB signals. If any one of these signals is lost, the LCD panel would be damaged.
 - Obey the supply voltage sequence. If wrong sequence is applied, the module would be damaged.
- (4) Cautions for the atmosphere
 - Dew drop atmosphere should be avoided.
 - Do not store and/or operate the LCD module in a high temperature and/or humidity atmosphere. Storage in an electro-conductive polymer packing pouch and under relatively low temperature atmosphere is recommended.
- (5) Cautions for the module characteristics
 - Do not apply fixed pattern data signal to the LCD module at product aging.
 - Applying fixed pattern for a long time may cause image sticking.
- (6) Other cautions
 - Do not disassemble and/or re-assemble LCD module.
 - Do not re-adjust variable resistor or switch etc.
 - When returning the module for repair or etc., Please pack the module not to be broken. We recommend to use the original shipping packages.

www.jxlcd.com

SPEC. NUMBER S865-5001	SPEC. TITLE HT190WG1-602 Product Specification	PAGE 22 OF 29
---------------------------	---	------------------



PRODUCT GROUP

REV

ISSUE DATE

TFT- LCD PRODUCT

0

2010.09.30

13.0 PRODUCT SERIAL NUMBER

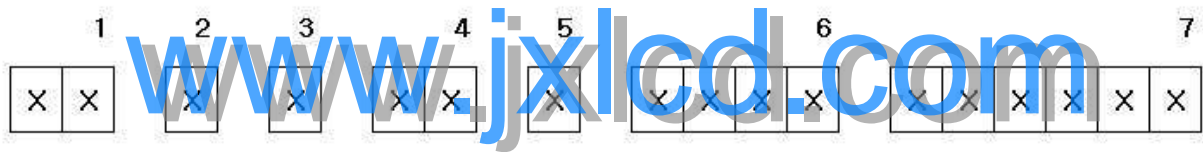

Type

No 1. Control

No 2. Rank

No 3. Line Classification

No 4. Year(2001 : 01, 2002 : 02, ...)

No 5. Month(1, 2, 3, ...,9 X, Y, Z)

No 6 **Internal use**

No 7. Serial No.

<p>SPEC. NUMBER S865-5001</p>	<p>SPEC. TITLE HT190WG1-602 Product Specification</p>	<p>PAGE 23 OF 29</p>
-----------------------------------	---	--------------------------

14.0 Packing

14.1 Packing Order

Put Pad into the box.

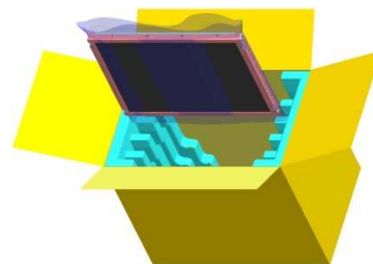
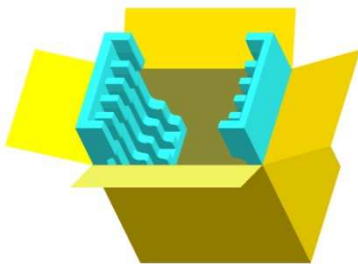

As shown in the figure, place the Modules bundled by shielding bag in the box.

After sealing the box, attach Packing Label on the attach position sign area of the box.

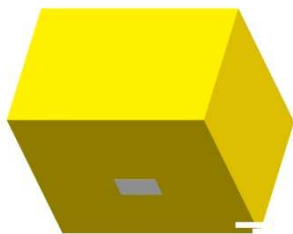

Place a cover on the top of the box.

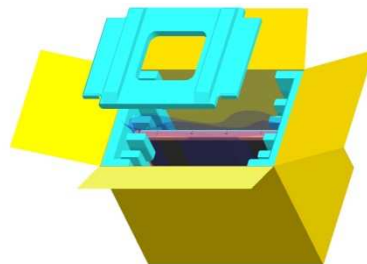



PRODUCT GROUP

REV

ISSUE DATE

TFT- LCD PRODUCT

0

2010.09.30

14.2 Packing Note

- Box Dimension : 346mm(W) × 526mm(D) × 448mm(H)
- Package Quantity in one Box : 7pcs

14.3 Box label

- Label Size : 108 mm (L) × 56 mm (W)
- Contents
Model : HT190WG1
Q`ty : Module Q`ty in one box
Serial No. : Box Serial No. See next page for detail description.
Date : Packing Date
FG Code : FG Code of Product

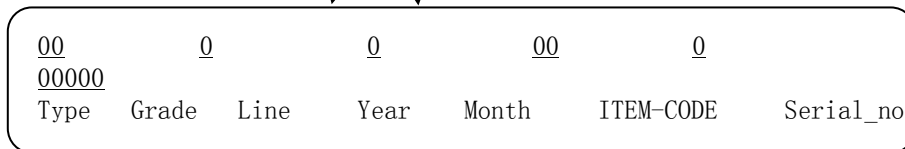

SPEC. NUMBER S865-5001	SPEC. TITLE HT190WG1-602 Product Specification	PAGE 25 OF 29
---------------------------	---	------------------

15.0 Appendix

Figure 1. Measurement Set Up

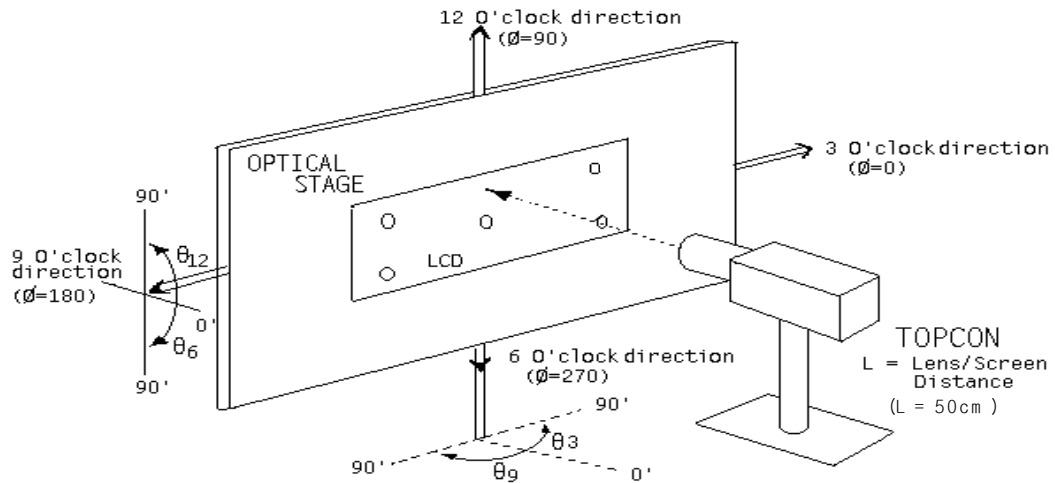

Figure 2. White Luminance and Uniformity Measurement Locations (9 points)

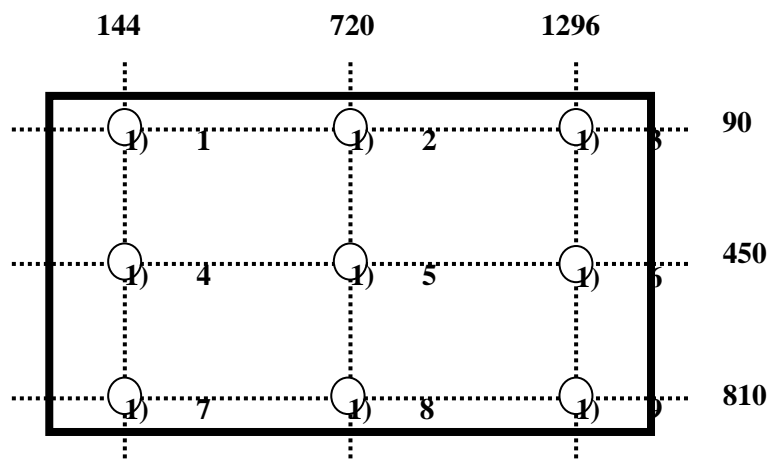
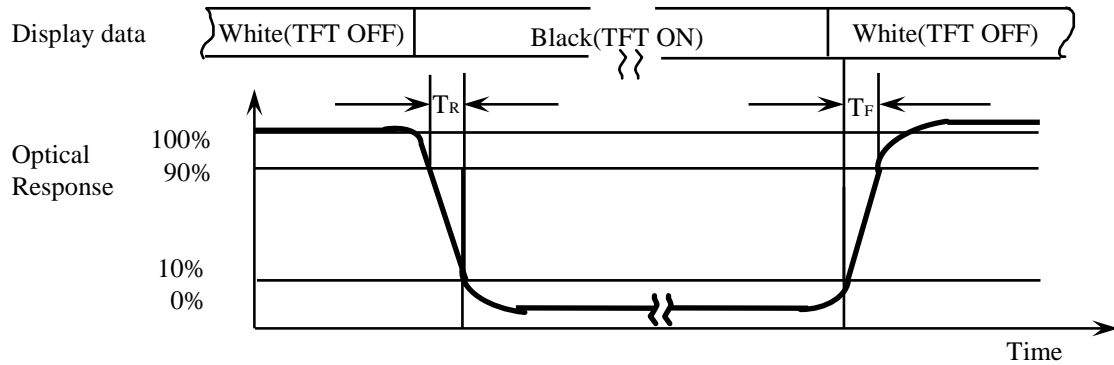
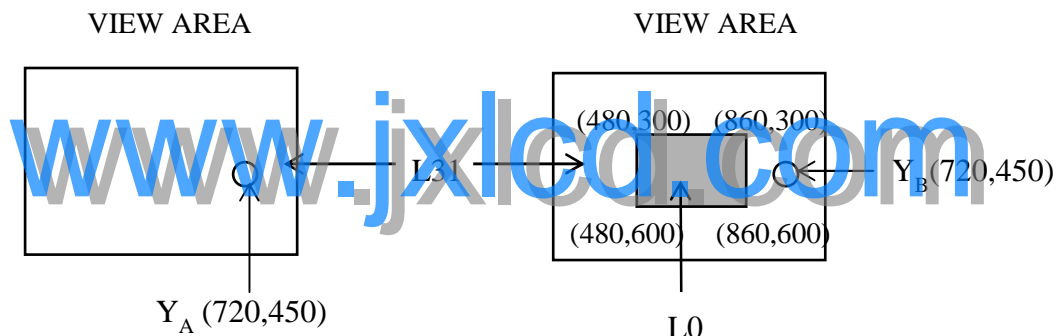

Figure 3. Response Time Testing

Figure 4. Cross Modulation Test Description

$$\text{Cross-Talk (\%)} = \left| \frac{Y_B - Y_A}{Y_A} \right| \times 100$$

Where: Y_A = Initial luminance of measured area (cd/m^2)

Y_B = Subsequent luminance of measured area (cd/m^2)

The location measured will be exactly the same in both patterns

Figure 5. TFT-LCD Module Outline Dimensions (Front view)



SPEC. NUMBER

S865-5001

SPEC. TITLE

HT190WG1-602 Product Specification

PAGE

28 OF 29

Figure 6. TFT-LCD Module Outline Dimensions (Rear view)

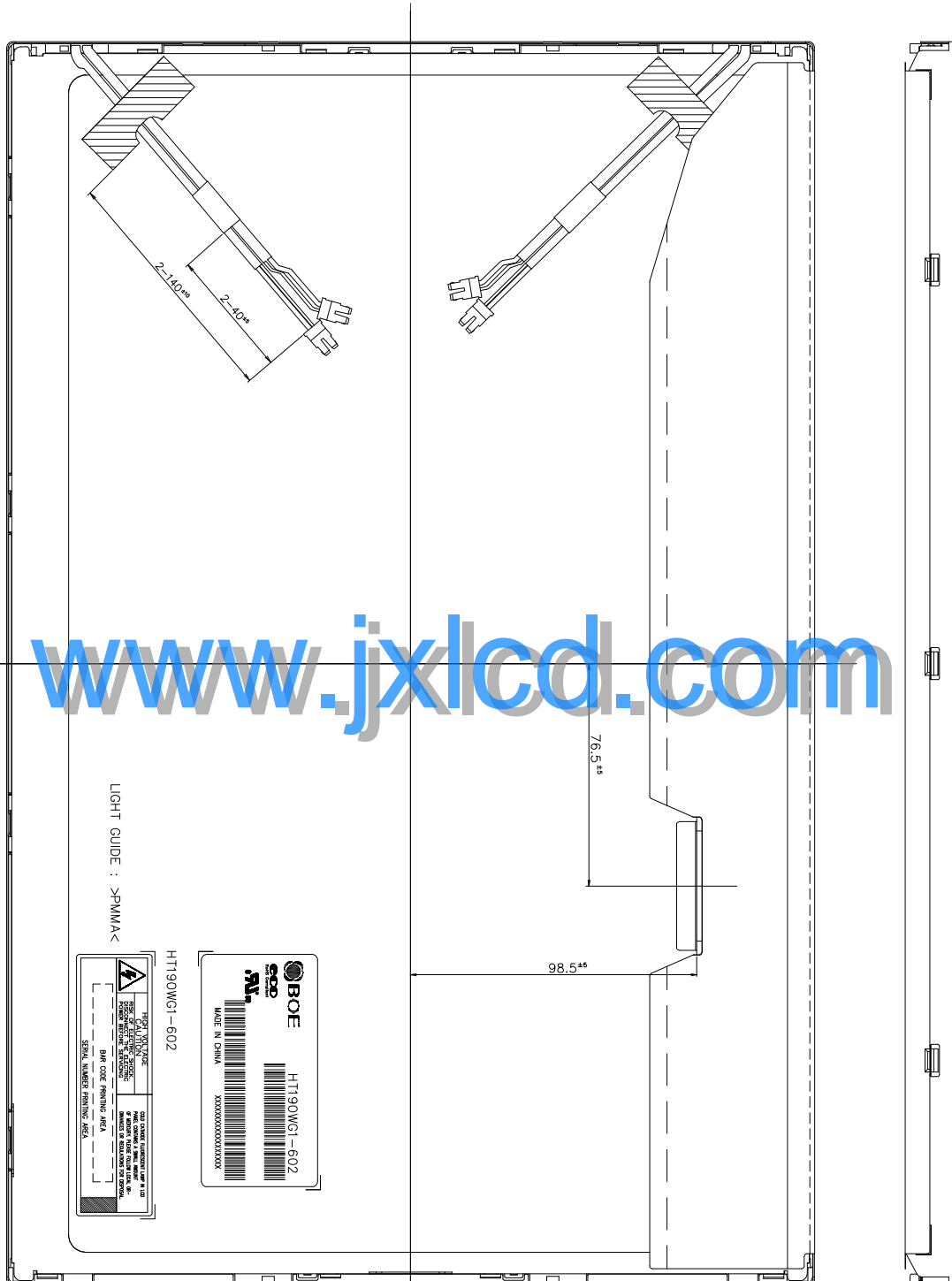

SPEC. NUMBER

S865-5001

SPEC. TITLE

HT190WG1-602 Product Specification

PAGE

29 OF 29