



PROPRIETARY NOTE
THIS SPECIFICATION IS THE PROPERTY OF BOE HF AND SHALL NOT BE REPRODUCED OR COPIED WITHOUT THE WRITTEN PERMISSION OF BOE OT AND MUST BE RETURNED TO BOE HF UPON ITS REQUEST.

SPEC. NUMBER	PRODUCT GROUP	REV.	ISSUE DATE	PAGE
	TFT-LCD	P1	2011.01.29	1 OF 23

**TITLE : HT260WX2-100 Open Cell
Preliminary Product Specification
Rev. P1**



京东方
BOE

PRODUCT GROUP

TFT- LCD PRODUCT

REV

P1

ISSUE DATE

2011.01.29

SPEC. NUMBER

SPEC. TITLE ; HT260WX2-100 Open Cell
Preliminary Product Specification

PAGE

3 OF 23

Contents

No	ITEM	Page
	REVISIONS HISTORY	2
	CONTENTS	3
1	GENERAL DESCRIPTION	4
	1.1 Introduction	
	1.2 Features	
	1.3 Applications	
	1.4 General Specification	
2	ABSOLUTE MAXIMUM RATINGS	6
3	ELECTRICAL SPECIFICATIONS	7
4	INTERFACE CONNECTION	8
	4.1 Open Cell Input Signal & power	
	4.2 LVDS Interface	
5	SIGNAL TIMING SPECIFICATIONS	10
	5.1 Timing Parameter	
	5.2 Signal Timing Waveform	
	5.3 Input Signals, Basic Display Colors & Cray Scale Of Colors	
	5.4 Power Sequence	
6	OPTICAL SPECIFICATIONS	14
7	MECHANICAL CHARACTERISTICS	16
8	PRODUCT SERIAL NUMBER	17
9	PACKING INFORMATION	18
10	HANDING & CAUTIONS	20
11	APPENDIX	21



PRODUCT GROUP

REV

ISSUE DATE

TFT- LCD PRODUCT

P1

2011.01.29

SPEC. NUMBER

SPEC. TITLE ; HT260WX2-100 Open Cell
Preliminary Product Specification

PAGE

4 OF 23

1.0 GENERAL DESCRIPTION

1.1 Introduction

HT260WX2-100 is a color active matrix TFT LCD Open Cell using amorphous silicon TFT's (Thin Film Transistors) as an active switching devices. This Open Cell has a 26.0inch diagonally measured active area with WXGA resolutions (1366 horizontal by 768 vertical pixel array). Each pixel is divided into RED, GREEN, BLUE dots which are arranged in vertical stripe and this Open Cell can display 16.7M colors. The TFT-LCD panel used for this Open Cell is adapted for a low reflection and higher color type.

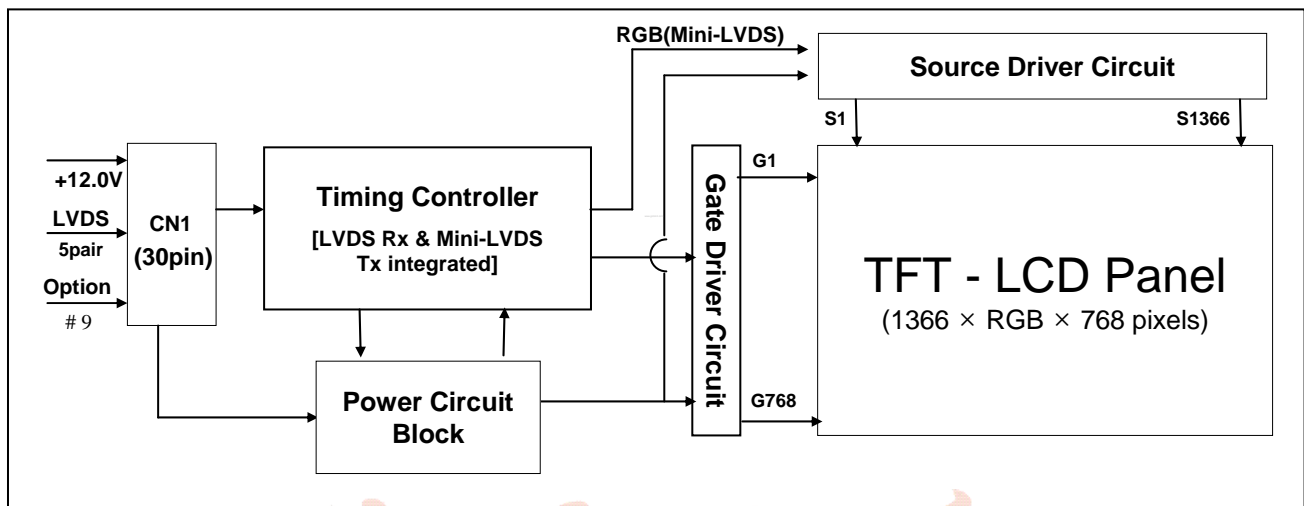

液晶仓库
www.gotolcd.com

1.2 Features

- LVDS Interface with 1 pixel / clock
- High-speed response
- Lower Color shift Image Quality
- 6-bit Hi-FRC color depth, display 16.7M colors
- High luminance and contrast ratio, low reflection and wide viewing angle
- DE (Data Enable) only mode
- RoHS Compliant



PRODUCT GROUP

REV

ISSUE DATE

TFT- LCD PRODUCT

P1

2011.01.29

SPEC. NUMBER

SPEC. TITLE ; HT260WX2-100 Open Cell
Preliminary Product Specification

PAGE

5 OF 23

1.3 Application

- Home Alone Multimedia TFT-LCD TV
- Display Terminals for Control System
- High Definition TV(HD TV)
- AV application Products

1.4 General Specification

< Table 1. General Specifications >

Parameter	Specification	Unit	Remarks
Active area	575.769(W) x 323.712(H)	mm	
Number of pixels	1366(H) × 768(V)	pixels	
Pixel pitch	140.5(H) × RGB × 421.5(V)	μm	
Pixel arrangement	Pixels RGB Vertical stripe		
Display colors	16.7M(6bits + Hi FRC)	colors	
Display mode	Transmission mode, Normally White		
Weight	830	g	
Power Consumption	2W	Watt	
Surface Treatment	Haze 25%, 3H, Semi-glare treatment (Front Polarizer)		
Open Cell TR.	6.9	%	

2.0 ABSOLUTE MAXIMUM RATINGS

The followings are maximum values which, if exceed, may cause faulty operation or damage to the unit. The operational and non-operational maximum voltage and current values are listed in Table 2.

< Table 2. LCD Module Electrical Specifications >

[VSS=GND=0V]

Parameter	Symbol	Min.	Max.	Unit	Remarks
Power Supply Voltage	VDD	VSS-0.3	13	V	Ta = 25 °C
Operating Temperature	T _{OP}	0	+50	°C	1)
	T _{SUR}	0	+60	°C	
Storage Temperature	T _{ST}	-20	+60	°C	
Operating Ambient Humidity	Hop	10	80	%RH	
Storage Humidity	Hst	10	80	%RH	

Note : 1) Temperature and relative humidity range are shown in the figure below.

Wet bulb temperature should be 39 °C max. and no condensation of water.

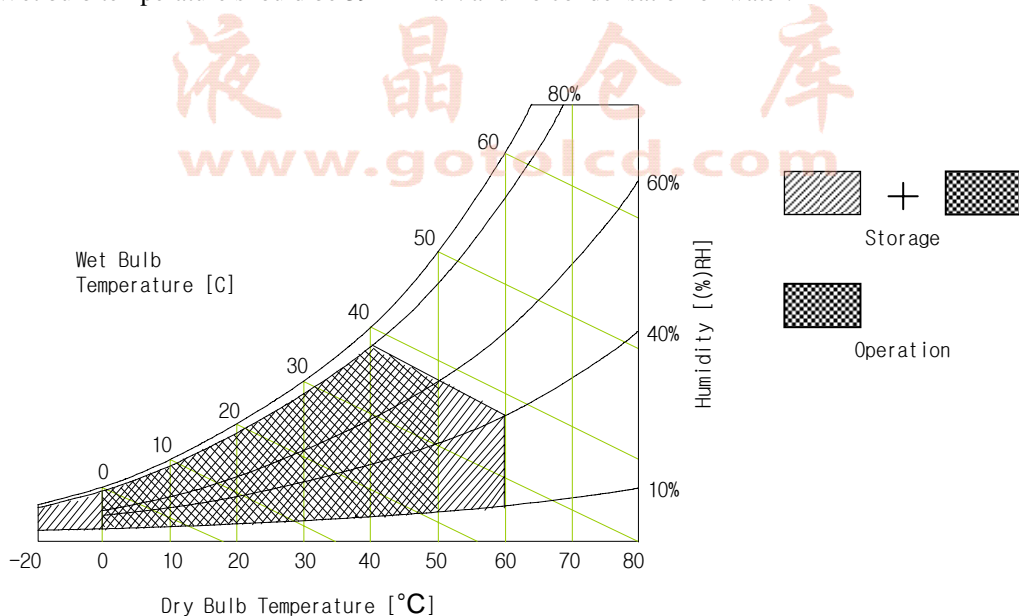



PRODUCT GROUP

REV

ISSUE DATE

TFT- LCD PRODUCT

P1

2011.01.29

SPEC. NUMBER

SPEC. TITLE ; HT260WX2-100 Open Cell
Preliminary Product Specification

PAGE

7 OF 23

3.0 ELECTRICAL SPECIFICATIONS

3.1 TFT LCD Module

< Table 3. LCD Module Electrical Specifications >

[Ta =25±2 °C]

Parameter	Symbol	Values			Unit	Notes	
		Min	Typ	Max			
Power Supply Input Voltage	VDD	11.4	12	12.6	V		
Power Supply Ripple Voltage	VRP			300	mV		
Power Supply Current	IDD	-	170	300	mA	1	
Power Consumption	PDD	-	2	3.5	Watt		
Rush current	IRUSH	-	-	3.0	A	2	
LVDS Interface	Differential Input High Threshold Voltage	VLVTH	+100		mV		
	Differential Input Low Threshold Voltage	VLVTL		-100	mV		
	Common Input Voltage	VLVC	1.0	1.2	1.4	V	
CMOS Interface	Input High Threshold Voltage	VIH	2.7	-	3.3	V	
	Input Low Threshold Voltage	VIL	0	-	0.7	V	

Notes : 1. The supply voltage is measured and specified at the interface connector of LCM.
The current draw and power consumption specified is for VDD=12.0V, Frame rate=60Hz and Clock frequency = 75.4MHz. Test Pattern of power supply current

- a) Typ : Black Pattern
- b) Max : Sub Dot Pattern

2. The duration of rush current is about 2ms and rising time of Power Input is 1ms(min)

White : 255Gray
Black : 0Gray

Mosaic Pattern(8 x 6)

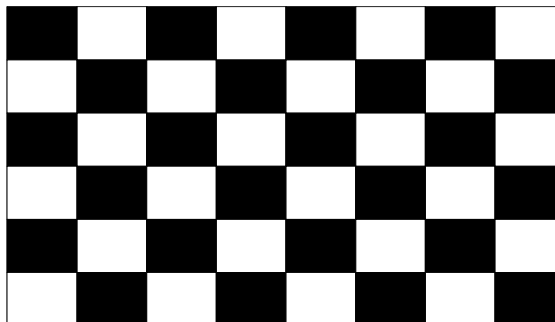



PRODUCT GROUP

REV

ISSUE DATE

TFT- LCD PRODUCT

P1

2011.01.29

SPEC. NUMBER

SPEC. TITLE ; HT260WX2-100 Open Cell Preliminary Product Specification

PAGE

8 OF 23

4.0 INTERFACE CONNECTION

4.1 Module Input Signal & Power

- Connector : IS100-L30B-C23(Manufactured by UJU) or Equivalent.

< Table 4. LCM Module Input Connector Pin Configuration >

Pin No	Symbol	Description	Pin No	Symbol	Description
1	VDD	Power Supply +12.0V	16	RX1+	LVDS Receiver Signal(+)
2	VDD	Power Supply +12.0V	17	GND	Ground
3	VDD	Power Supply +12.0V	18	RX2-	LVDS Receiver Signal(-)
4	VDD	Power Supply +12.0V	19	RX2+	LVDS Receiver Signal(+)
5	GND	Ground	20	GND	Ground
6	GND	Ground	21	RCLK-	LVDS Receiver Clock Signal(-)
7	GND	Ground	22	RCLK+	LVDS Receiver Clock Signal(+)
8	GND	Ground	23	GND	Ground
9	LVDS_SEL	'L'=JEIDA , 'H' or NC= VESA	24	RX3-	LVDS Receiver Signal(-)
10	NC	No Connection	25	RX3+	LVDS Receiver Signal(+)
11	GND	Ground	26	GND	Ground
12	RX0-	LVDS Receiver Signal(-)	27	NC	No Connection
13	RX0+	LVDS Receiver Signal(+)	28	NC	No Connection
14	GND	Ground	29	GND	Ground
15	RX1-	LVDS Receiver Signal(-)	30	GND	Ground

Notes : 1. NC(Not Connected) : This pins are only used for BOE internal operations.

2. Input Level of LVDS signal is based on the IEA 664 Standard.

3. LVDS_SEL : This pin is used for selecting LVDS signal data format.

If this Pin : High (3.3V) or Open (NC) → Normal NS LVDS format

Otherwise : Low (GND) → JEIDA LVDS format

Sequence : On = Vdd ≥ LVDS Option ≥ Interface signal

Off = Interface signal ≥ LVDS Option ≥ Vdd

Rear view of LCM

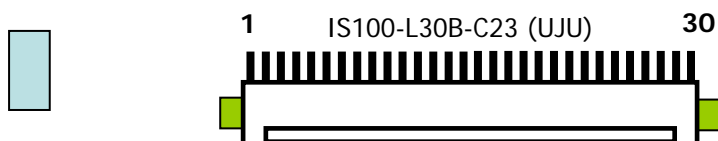



PRODUCT GROUP

REV

ISSUE DATE

TFT- LCD PRODUCT

P1

2011.01.29

SPEC. NUMBER

SPEC. TITLE ; HT260WX2-100 Open Cell
Preliminary Product Specification

PAGE

9 OF 23

4.2 LVDS Interface

- LVDS Receiver : Timing Controller (LVDS Rx merged)
- LVDS Data : Pixel Data

< Table 5. LCM Module Input Connector Pin Configuration >

	LVDS Pin	Vesa Data format	JEIDA Data format	Remark
TxOUT/RxIN0	TxIN/RxOUT0	Red0 [LSB]	R2	
	TxIN/RxOUT1	Red1	R3	
	TxIN/RxOUT2	Red2	R4	
	TxIN/RxOUT3	Red3	R5	
	TxIN/RxOUT4	Red4	R6	
	TxIN/RxOUT6	Red5	R7 [MSB]	
	TxIN/RxOUT7	Green0 [LSB]	G2	
TxOUT/RxIN1	TxIN/RxOUT8	Green1	G3	
	TxIN/RxOUT9	Green2	G4	
	TxIN/RxOUT12	Green3	G5	
	TxIN/RxOUT13	Green4	G6	
	TxIN/RxOUT14	Green5	G7 [MSB]	
	TxIN/RxOUT15	Blue0 [LSB]	B2	
	TxIN/RxOUT18	Blue1	B3	
TxOUT/RxIN2	TxIN/RxOUT19	Blue2	B4	
	TxIN/RxOUT20	Blue3	B5	
	TxIN/RxOUT21	Blue4	B6	
	TxIN/RxOUT22	Blue5	B7 [MSB]	
	TxIN/RxOUT24	HSYNC	HSYNC	
	TxIN/RxOUT25	VSYNC	VSYNC	
	TxIN/RxOUT26	DEN	DEN	
TxOUT/RxIN3	TxIN/RxOUT27	Red6	R0 [LSB]	
	TxIN/RxOUT5	Red7 [MSB]	R1	
	TxIN/RxOUT10	Green6	G0 [LSB]	
	TxIN/RxOUT11	Green7 [MSB]	G1	
	TxIN/RxOUT16	Blue6	B0 [LSB]	
	TxIN/RxOUT17	Blue7 [MSB]	B1	
	TxIN/RxOUT23	Reserved	Reserved	



PRODUCT GROUP

REV

ISSUE DATE

TFT- LCD PRODUCT

P1

2011.01.29

SPEC. NUMBER

SPEC. TITLE ; HT260WX2-100 Open Cell
Preliminary Product Specification

PAGE

10 OF 23

5.0 SIGNAL TIMING SPECIFICATION

5.1 Timing Parameters (DE only mode)

< Table 6. Timing Table >

ITEM	Symbol		Min	Typ	Max	Unit	Note
CLK	Period	t_{CLK}	11.8	13.3	17.9	ns	
	Frequency	-	56	75.4	85.0	MHz	
Hsync	Period	t_{HP}	1442	1560	1936	t_{CLK}	
	Frequency	f_H	39.4	48.4	53	KHz	
Vsync	Period	t_{VP}	778	806	888	t_{HP}	
	Frequency	f_V	50	60	65	Hz	
Horizontal Active Display Term	Valid	t_{HV}	-	1366	-	t_{CLK}	
	Total	t_{HP}	1442	1560	1936	t_{CLK}	
Vertical Active Display Term	Valid	t_{VV}	-	768	-	t_{HP}	
	Total	t_{VP}	778	806	888	t_{HP}	

Notes: This product is DE only mode. The input of Hsync & Vsync signal does not have an effect on normal operation.





PRODUCT GROUP

REV

ISSUE DATE

TFT- LCD PRODUCT

P1

2011.01.29

SPEC. NUMBER

SPEC. TITLE ; HT260WX2-100 Open Cell
Preliminary Product Specification

PAGE

11 OF 23

5.2 Signal Timing Waveform

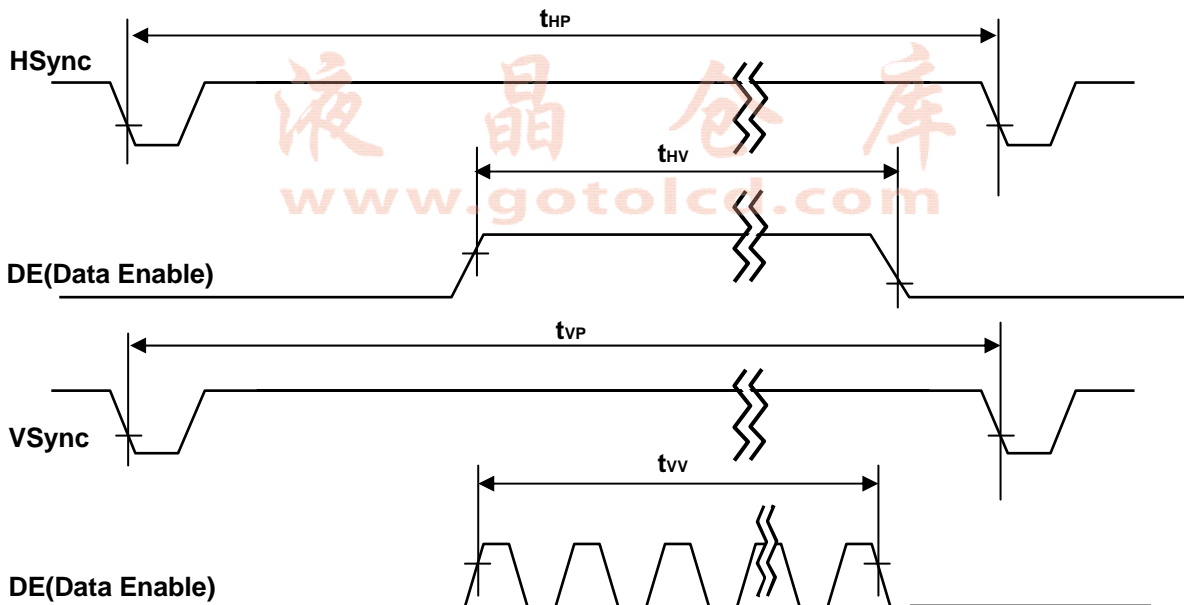
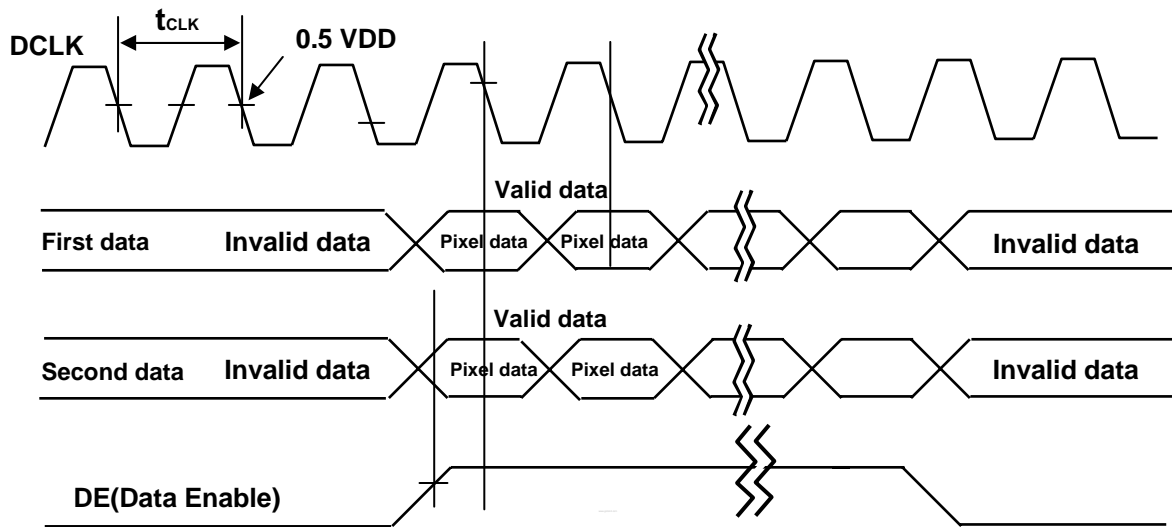



PRODUCT GROUP

REV

ISSUE DATE

TFT- LCD PRODUCT

P1

2011.01.29

SPEC. NUMBER

SPEC. TITLE ; HT260WX2-100 Open Cell
Preliminary Product Specification

PAGE

12 OF 23

5.3 Input Signals, Basic Display Colors & Gray Scale Of Colors

< Table 7. Input Signal and Display Color Table >

Color & Gray Scale		Input Data Signal																						
		Red Data						Green Data						Blue Data										
		R7	R6	R5	R4	R3	R2	R1	R0	G7	G6	G5	G4	G3	G2	G1	G0	B7	B6	B5	B4	B3	B2	B1
Basic Colors	Black	0	0	0	0	0	0	0	0	0	0	0	0	0	0	0	0	0	0	0	0	0	0	0
	Blue	0	0	0	0	0	0	0	0	0	0	0	0	0	0	0	0	1	1	1	1	1	1	1
	Green	0	0	0	0	0	0	0	0	1	1	1	1	1	1	1	1	0	0	0	0	0	0	0
	Cyan	0	0	0	0	0	0	0	0	1	1	1	1	1	1	1	1	1	1	1	1	1	1	1
	Red	1	1	1	1	1	1	1	1	0	0	0	0	0	0	0	0	0	0	0	0	0	0	0
	Magenta	1	1	1	1	1	1	1	1	0	0	0	0	0	0	0	0	1	1	1	1	1	1	1
	Yellow	1	1	1	1	1	1	1	1	1	1	1	1	1	1	1	1	0	0	0	0	0	0	0
	White	1	1	1	1	1	1	1	1	1	1	1	1	1	1	1	1	1	1	1	1	1	1	1
Gray Scale of Red	Black	0	0	0	0	0	0	0	0	0	0	0	0	0	0	0	0	0	0	0	0	0	0	
	△	0	0	0	0	0	0	1	0	0	0	0	0	0	0	0	0	0	0	0	0	0	0	
	Darker	0	0	0	0	0	0	1	0	0	0	0	0	0	0	0	0	0	0	0	0	0	0	
	△	↑						↑						↑										
	▽	↓						↓						↓										
	Brighter	1	1	1	1	1	1	0	1	0	0	0	0	0	0	0	0	0	0	0	0	0	0	0
	▽	1	1	1	1	1	1	0	0	0	0	0	0	0	0	0	0	0	0	0	0	0	0	0
	Red	1	1	1	1	1	1	1	1	0	0	0	0	0	0	0	0	0	0	0	0	0	0	0
Gray Scale of Green	Black	0	0	0	0	0	0	0	0	0	0	0	0	0	0	0	0	0	0	0	0	0	0	
	△	0	0	0	0	0	0	0	0	0	0	0	0	0	0	0	1	0	0	0	0	0	0	
	Darker	0	0	0	0	0	0	0	0	0	0	0	0	0	0	1	0	0	0	0	0	0	0	
	△	↑						↑						↑										
	▽	↓						↓						↓										
	Brighter	0	0	0	0	0	0	0	1	1	1	1	1	1	0	1	0	0	0	0	0	0	0	
	▽	0	0	0	0	0	0	0	1	1	1	1	1	1	1	0	0	0	0	0	0	0	0	
	Green	0	0	0	0	0	0	0	1	1	1	1	1	1	1	1	0	0	0	0	0	0	0	
Gray Scale of Blue	Black	0	0	0	0	0	0	0	0	0	0	0	0	0	0	0	0	0	0	0	0	0	0	
	△	0	0	0	0	0	0	0	0	0	0	0	0	0	0	0	0	0	0	0	0	0	1	
	Darker	0	0	0	0	0	0	0	0	0	0	0	0	0	0	0	0	0	0	0	0	0	1	
	△	↑						↑						↑										
	▽	↓						↓						↓										
	Brighter	0	0	0	0	0	0	0	0	0	0	0	0	0	0	0	1	1	1	1	1	1	0	1
	▽	0	0	0	0	0	0	0	0	0	0	0	0	0	0	0	1	1	1	1	1	1	1	0
	Blue	0	0	0	0	0	0	0	0	0	0	0	0	0	0	0	1	1	1	1	1	1	1	1
Gray Scale of White	Black	0	0	0	0	0	0	0	0	0	0	0	0	0	0	0	0	0	0	0	0	0	0	
	△	0	0	0	0	0	0	1	0	0	0	0	0	0	0	1	0	0	0	0	0	0	1	
	Darker	0	0	0	0	0	0	1	0	0	0	0	0	0	1	0	0	0	0	0	0	0	1	
	△	↑						↑						↑										
	▽	↓						↓						↓										
	Brighter	1	1	1	1	1	1	0	1	1	1	1	1	1	0	1	1	1	1	1	1	1	0	1
	▽	1	1	1	1	1	1	0	1	1	1	1	1	1	1	0	1	1	1	1	1	1	1	0
	White	1	1	1	1	1	1	1	1	1	1	1	1	1	1	1	1	1	1	1	1	1	1	1

5.4 Power Sequence

To prevent a latch-up or DC operation of the LCD module, the power on/off sequence shall be as shown in below

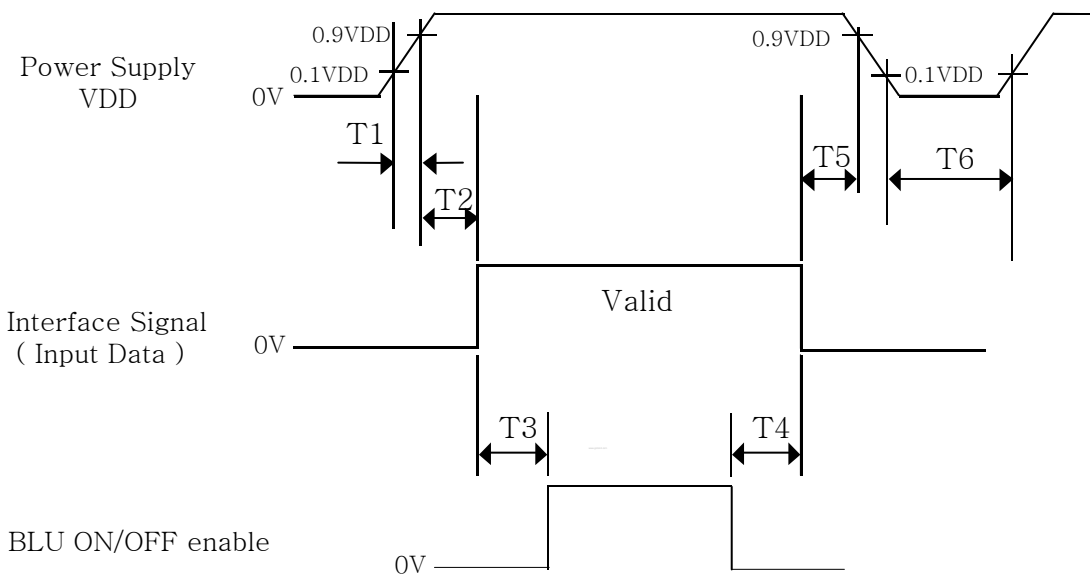

< Table 8. Sequence Table >

Parameter	Values			Units
	Min	Typ	Max	
T1	0.5	-	20	ms
T2	0	-	50	ms
T3	200	-	-	ms
T4	200	-	-	ms
T5	0	-	100	ms
T6	1	-	-	s

Notes:

1. When the power supply VDD is 0V, Keep the level of input signals on the low or keep high impedance.
2. Do not keep the interface signal high impedance when power is on.
3. Back Light must be turn on after power for logic and interface signal are valid.



PRODUCT GROUP

REV

ISSUE DATE

TFT- LCD PRODUCT

P1

2011.01.29

SPEC. NUMBER

SPEC. TITLE ; HT260WX2-100 Open Cell
Preliminary Product Specification

PAGE

14 OF 23

6.0 OPTICAL SPECIFICATION

The test of Optical specifications shall be measured in a dark room (ambient luminance ≤ 1 lux and temperature = 25 ± 2 °C) with the equipment of Luminance meter system (Goniometer system and TOPCON BM-5) and test unit shall be located at an approximate distance 50cm from the LCD surface at a viewing angle of Θ and Φ equal to 0° . We refer to $\Theta_{\phi=0}$ ($=\Theta_3$) as the 3 o'clock direction (the "right"), $\Theta_{\phi=90}$ ($=\Theta_{12}$) as the 12 o'clock direction ("upward"), $\Theta_{\phi=180}$ ($=\Theta_9$) as the 9 o'clock direction ("left") and $\Theta_{\phi=270}$ ($=\Theta_6$) as the 6 o'clock direction ("bottom"). While scanning Θ and/or Φ , the center of the measuring spot on the Display surface shall stay fixed. The measurement shall be executed after 30 minutes warm-up period. VDD shall be 12.0V +/-10% at 25°C. Optimum viewing angle direction is 6 'clock.

[VDD = 12.0V, Frame rate = 60Hz, Ta = 25 ± 2 °C]

< Table 9. Optical Table >

Parameter		Symbol	Condition	Min	Typ	Max	Unit	Remark
Viewing Angle	Horizontal	Θ_3	CR > 10		80		Deg.	Note 1
		Θ_9			80		Deg.	
	Vertical	Θ_{12}			80		Deg.	
		Θ_6			70		Deg.	
Cell Transmittance			$\Theta = 0^\circ$ with BOE module	?	6.9	?		Note 5
Contrast ratio		CR		600:1	800:1	-		Note 2
Reproduction of color	White	W_x	$\Theta = 0^\circ$ (Center) Normal Viewing Angle	TYP. - 0.03	0.280	TYP. + 0.03		Note 3
		W_y			0.290			
	Red	R_x			0.636			
		R_y			0.335			
	Green	G_x			0.291			
		G_y			0.603			
	Blue	B_x			0.146			
		B_y			0.061			
Response Time		T_g		-	5	10	ms	Note 4
Gamma Scale				2.0	2.2	2.4		

 京东方 BOE	PRODUCT GROUP	REV	ISSUE DATE
	TFT- LCD PRODUCT	P1	2011.01.29
SPEC. NUMBER	SPEC. TITLE ; HT260WX2-100 Open Cell Preliminary Product Specification		PAGE 15 OF 23

Note :

1. Viewing angle is the angle at which the contrast ratio is greater than 10. The viewing are determined for the horizontal or 3, 9 o'clock direction and the vertical or 6, 12 o'clock direction with respect to the optical axis which is normal to the LCD surface.
2. Contrast measurements shall be made at viewing angle of $\theta = 0^\circ$ and at the center of the LCD surface. Luminance shall be measured with all pixels in the view field set first to white, then to the dark (black) state. (See FIGURE 1 shown in Appendix) Luminance Contrast Ratio (CR) is defined mathematically.

$$CR = \frac{\text{Luminance when displaying a white raster}}{\text{Luminance when displaying a black raster}}$$

3. The color chromaticity coordinates specified in Table 9. shall be calculated from the spectral data measured with all pixels first in red, green, blue and white. Measurements shall be made at the center of the panel.
4. The electro-optical response time measurements shall be made as FIGURE 2 shown in Appendix by switching the "data" input signal ON and OFF. The times needed for the luminance to change from 10% to 90% is Td, and 90% to 10% is Tr.
5. Definition of Transmittance (T%) :
Module is without signal input

$$\text{Transmittance} = \frac{\text{Luminance of LCD module}}{\text{Luminance of backlight}} * 100\%$$



PRODUCT GROUP

REV

ISSUE DATE

TFT- LCD PRODUCT

P1

2011.01.29

SPEC. NUMBER

SPEC. TITLE ; HT260WX2-100 Open Cell Preliminary Product Specification

PAGE

16 OF 23

7.0 MECHANICAL CHARACTERISTICS

7.1 Dimensional Requirements

FIGURE 3 (located in Appendix) shows mechanical outlines for the model HT260WX2-100 . Other parameters are shown in Table 10.

<Table 10. Dimensional Parameters>

Parameter	Specification	Unit
Weight	830 (typ)	gram
Active area	575.769(W) x 323.712(H)	mm
Pixel pitch	0.4215(H) × 0.4215(V)	mm
Number of pixels	1366(H) × 768(V) (1 pixel = R + G + B dots)	pixels

7.2 Semi-Glare and Polarizer Hardness.

The surface of the LCD has an semi-glare coating to minimize reflection and a coating to reduce scratching.



 京东方 BOE	PRODUCT GROUP	REV	ISSUE DATE
	TFT- LCD PRODUCT	P1	2011.01.29
SPEC. NUMBER	SPEC. TITLE ; HT260WX2-100 Open Cell Preliminary Product Specification		PAGE 17 OF 23

8.0 Product Serial Number

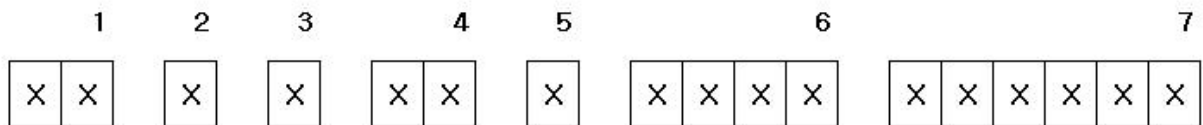

Type

No 1. Control

No 2. Rank

No 3. Line Classification(BOE HYDIS : H, LCM : L, BOE OT : A/B/C)

No 4. Year(2001 : 01, 2002 : 02, ...)

No 5. Month(1, 2, 3, ...,9 X, Y, Z)

No 6. FG Code

No 7. Serial No.

液晶仓库

www.gotolcd.com



PRODUCT GROUP

REV

ISSUE DATE

TFT- LCD PRODUCT

P1

2011.01.29

SPEC. NUMBER

SPEC. TITLE ; HT260WX2-100 Open Cell
Preliminary Product Specification

PAGE

18 OF 23

9.0 PACKING INFORMATION

BOE provides the standard shipping container for customers, unless customer specifies their packing information. The standard packing method and Barcode information are shown in below.

9.1 Packing Order

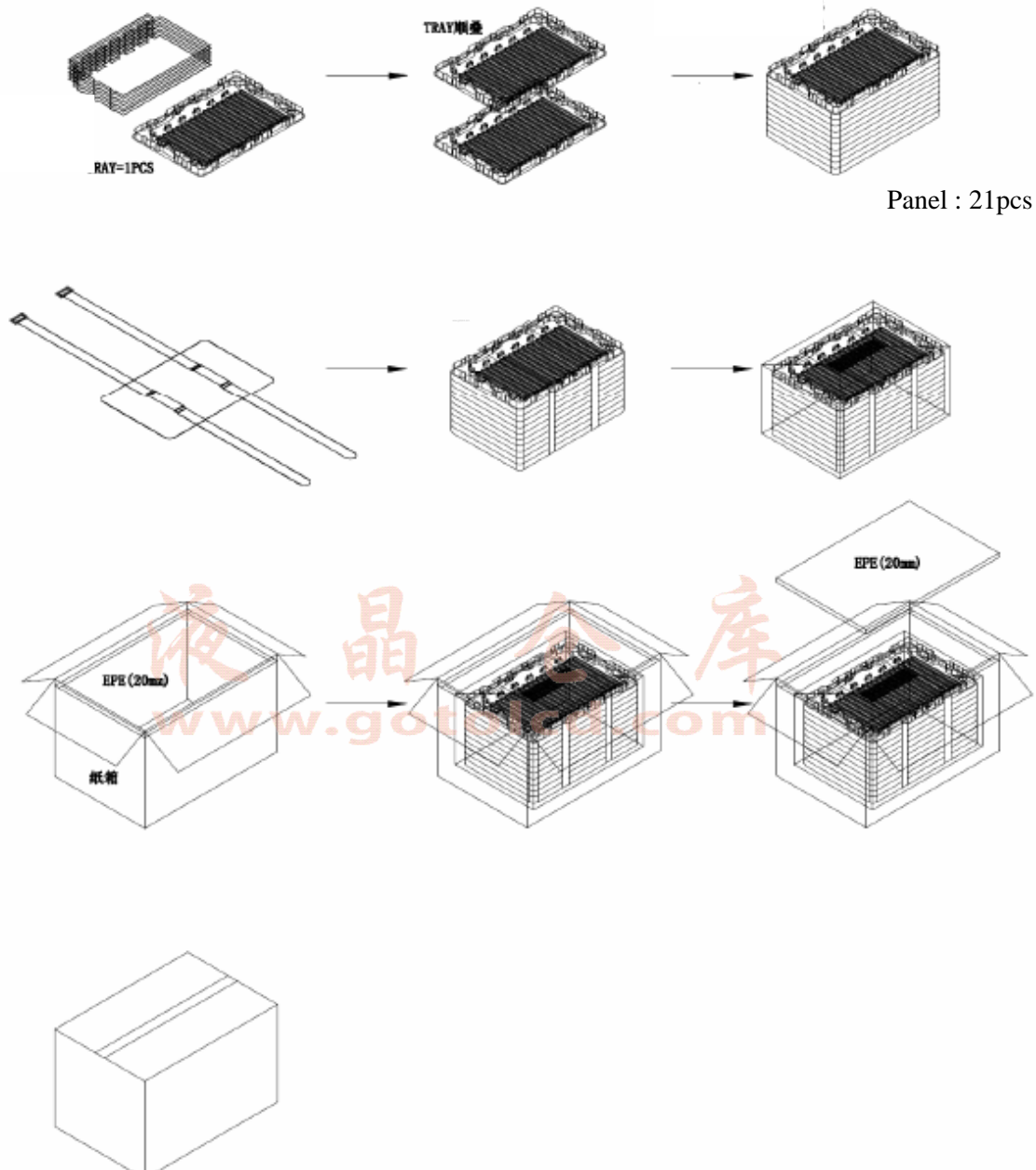

 京东方 BOE	PRODUCT GROUP	REV	ISSUE DATE
	TFT- LCD PRODUCT	P1	2011.01.29
SPEC. NUMBER	SPEC. TITLE ; HT260WX2-100 Open Cell Preliminary Product Specification		PAGE 19 OF 23

9.2 Packing Note

- Box Dimension : 753L× 528W× 272H
- Package Quantity in one Box : 21pcs

9.3 Box label

- Label Size : 108 mm (L) 56 mm (W)
- Contents
Model : HT260WX2
Serial No. : Box Serial No. See next page for detail description.
Date : Packing Date
FG Code : FG Code of Product

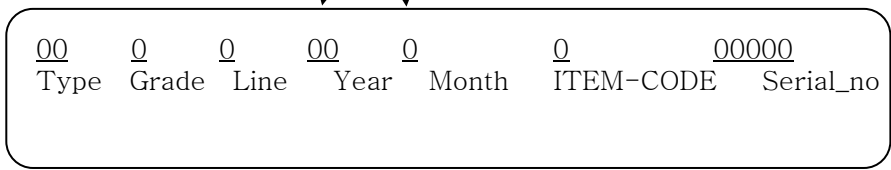
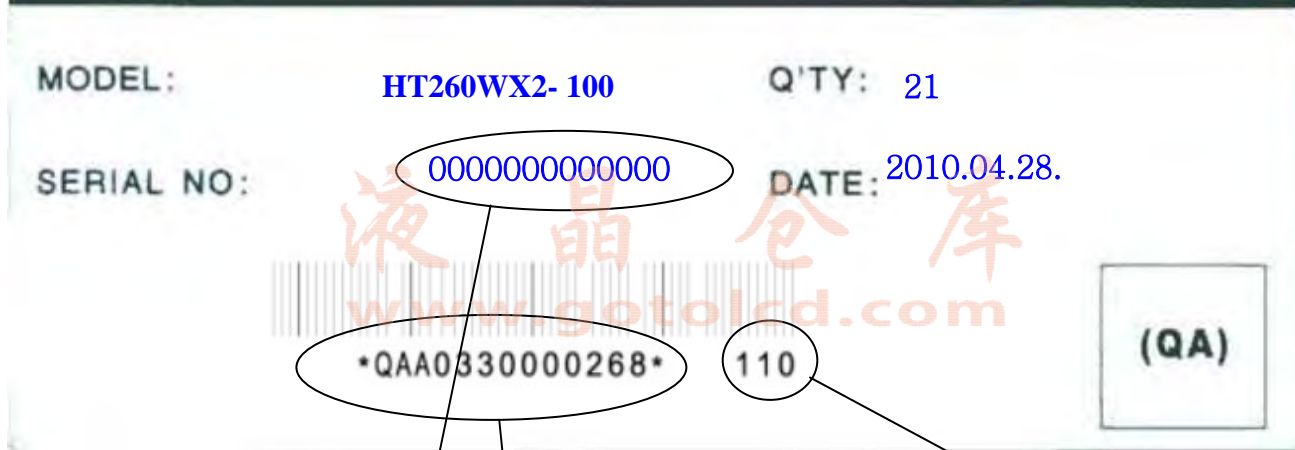

FG CODE

 京东方 BOE	PRODUCT GROUP	REV	ISSUE DATE
	TFT- LCD PRODUCT	P1	2011.01.29
SPEC. NUMBER	SPEC. TITLE ; HT260WX2-100 Open Cell Preliminary Product Specification		PAGE 20 OF 23

10.0 HANDLING & CAUTIONS

- (1) Cautions when taking out the module
 - Pick the pouch only, when taking out module from a shipping package.
- (2) Cautions for handling the module
 - As the electrostatic discharges may break the LCD module, handle the LCD module with care. Peel a protection sheet off from the LCD panel surface as slowly as possible.
 - As the LCD panel and back - light element are made from fragile glass material, impulse and pressure to the LCD module should be avoided.
 - As the surface of the polarizer is very soft and easily scratched, use a soft dry cloth without chemicals for cleaning.
 - Do not pull the interface connector in or out while the LCD module is operating.
 - Put the module display side down on a flat horizontal plane.
 - Handle connectors and cables with care.
- (3) Cautions for the operation
 - When the module is operating, do not lose CLK, ENAB signals. If any one of these signals is lost, the LCD panel would be damaged.
 - Obey the supply voltage sequence. If wrong sequence is applied, the module would be damaged.
- (4) Cautions for the atmosphere
 - Dew drop atmosphere should be avoided.
 - Do not store and/or operate the LCD module in a high temperature and/or humidity atmosphere. Storage in an electro-conductive polymer packing pouch and under relatively low temperature atmosphere is recommended.
- (5) Cautions for the module characteristics
 - Do not apply fixed pattern data signal to the LCD module at product aging.
 - Applying fixed pattern for a long time may cause image sticking.
- (6) Other cautions
 - Do not disassemble and/or re-assemble LCD module.
 - Do not re-adjust variable resistor or switch etc.
 - When returning the module for repair or etc., Please pack the module not to be broken. We recommend to use the original shipping packages.

11.0 APPENDIX

Figure 1. Measurement Set Up

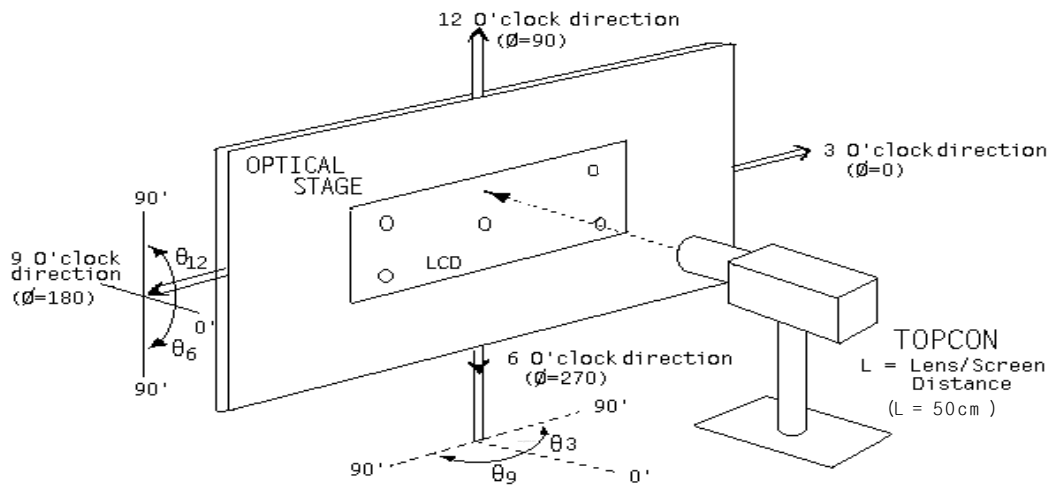

液晶仓库
www.gotolcd.com



京东方
BOE

PRODUCT GROUP

TFT- LCD PRODUCT

REV

P1

ISSUE DATE

2011.01.29

SPEC. NUMBER

SPEC. TITLE ; HT260WX2-100 Open Cell
Preliminary Product Specification

PAGE

22 OF 23

Figure 2. Response Time Testing

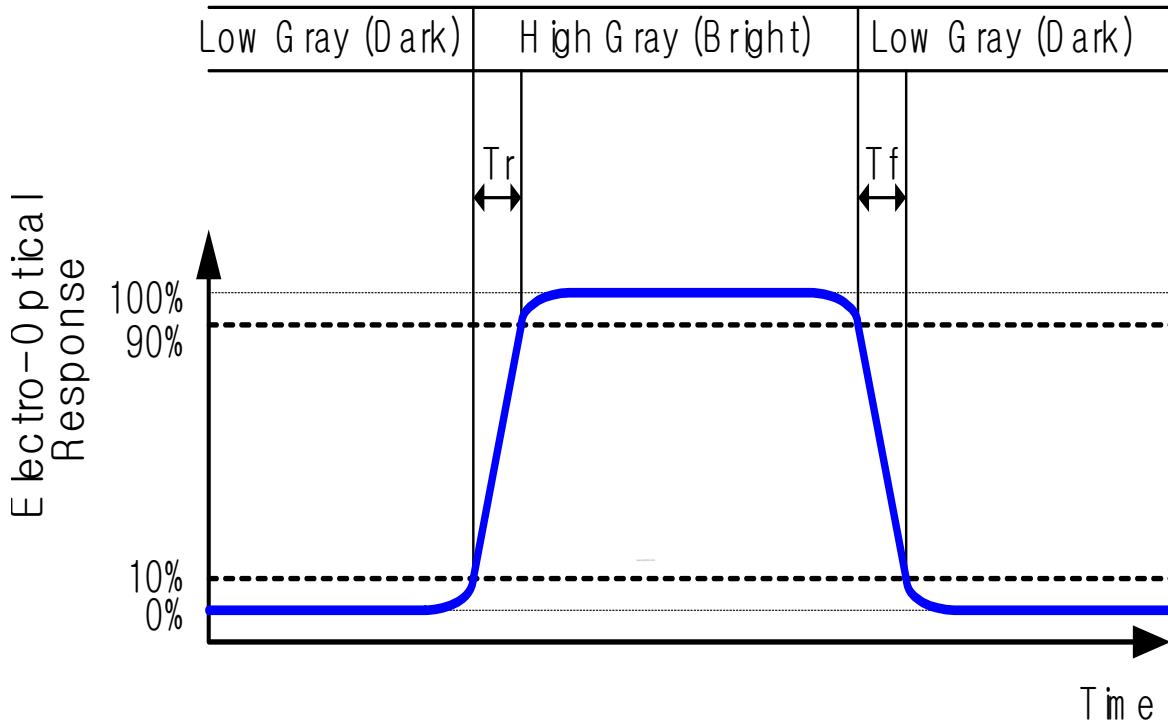

液晶仓库
www.gotolcd.com



PRODUCT GROUP

REV

ISSUE DATE

TFT- LCD PRODUCT

P1

2011.01.29

SPEC. NUMBER

SPEC. TITLE ; HT260WX2-100 Open Cell
Preliminary Product Specification

PAGE

23 OF 23

Figure 3. TFT-LCD Module Outline Dimensions (Front view)

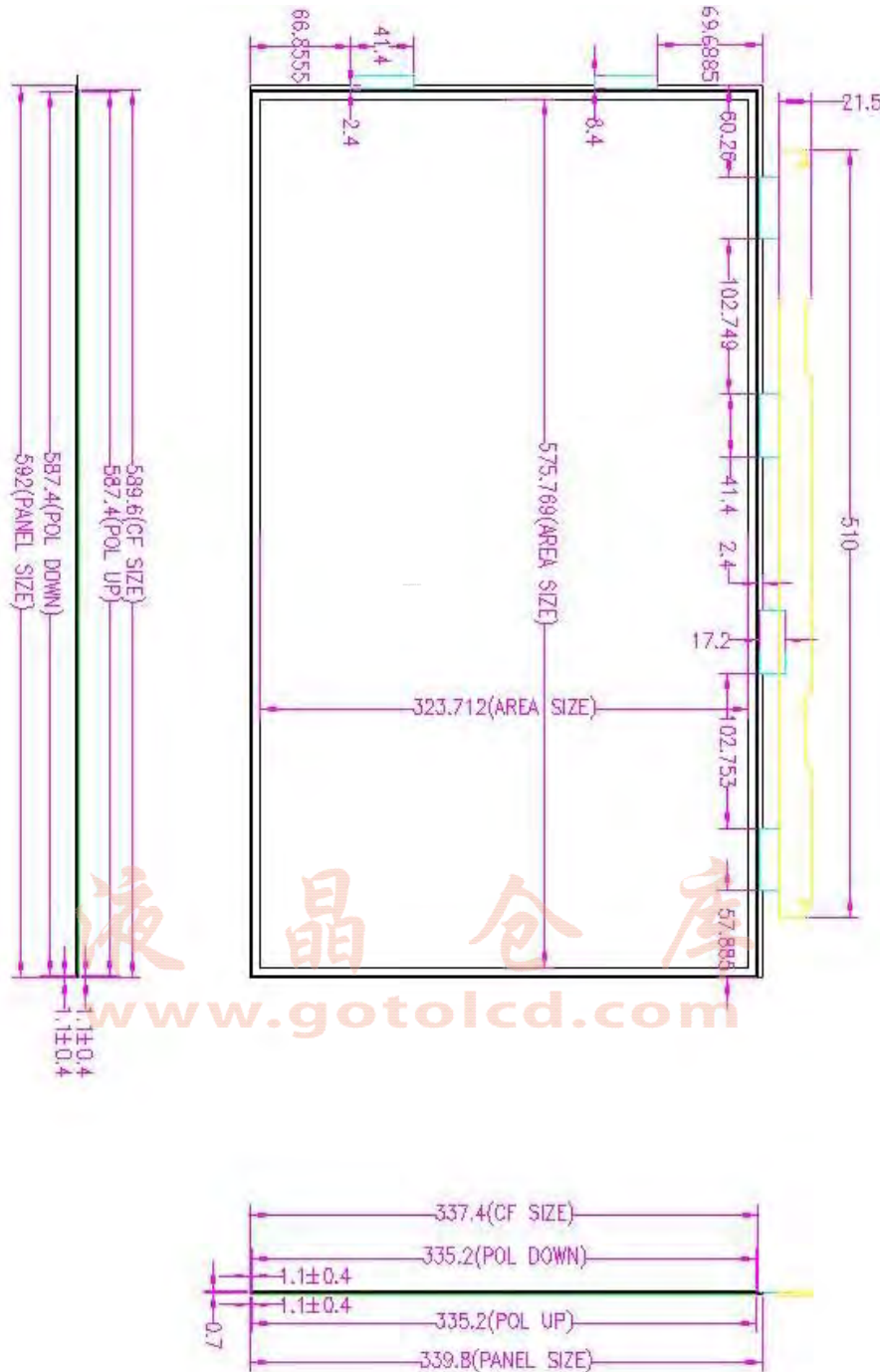

NOTE

1. Unspecified tolerances are to be $\pm 1.0\text{mm}$.
2. I/F CONNECTOR SPECIFICATION
IS100-L30B-C23 or equivalent
3. INVERTER CONNECTOR SPECIFICATION
Cvlux C10114M1HRL-LF or equivalent
4. USER MOUNTING TORQUE SPEC: 4~5kgf.cm