

### GENERAL DESCRIPTION

HT2802D is high performance primary sensing regulation and monolithic switching-mode power controller which is designed for small-power supply equipment with current mode control. Built-in accurate CV/CC control circuit. High integration design, a high performance power BJT and PFM controller and full protection circuits in single chip, to minimize external components and save the cost effectively. HT2802D can be simply designed a typical flyback switch converter, the unique driving technology promotes the characteristics of withstand voltage and achieves excellent converting efficiency

### FEATURES

- ◆ Built-in 800V power BJT;
- ◆ PSR control, eliminates Opto-coupler and TL431;
- ◆ Accurate CV/CC control
- ◆ Hysteresis over-temperature protection (OTP) circuit
- ◆ Higher efficiency and meet Level 6 efficiency standards
- ◆ Output voltage protection (OVP/UVLO)
- ◆ < 100 mW no-load consumption
- ◆ Auto-Restart function

### APPLICATIONS

- ◆ Handset/ Wireless Phone Chargers
- ◆ DSC/ Tablet Chargers
- ◆ Power Adaptors with limited output power

### TYPICAL APPLICATION CIRCUITRY

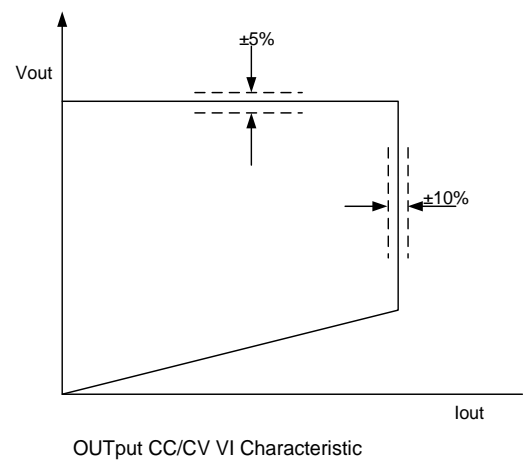
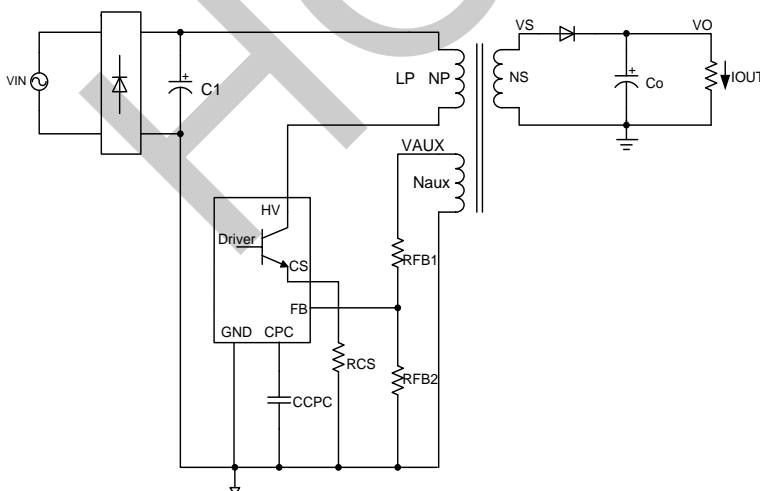

### PIN DEFINITION

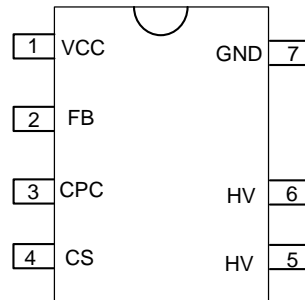

DIP7

#### PIN Function Description

Pin #	Name	Function Description
1	VCC	Power Supply Pin of IC. An external filter capacitor of Low ESR electrolytic capacitor is suggested to gain stable supply voltage .
2	FB	Output Feedback Pin to detect output condition through the auxiliary winding voltage of the transformer
3	CPC	Connected with a 100+nf capacitor, CPC Pin becomes output cable drop- out compensation Pin.
4	CS	Connect external primary current sensing resistor ( $R_{cs}$ ), IC can detect primary current via external sensing resistor. When voltage on the resistor surpasses maximum value, internal Power BJT will be turned off immediately
5-6	HV	The Collector of internal Power Transistor
7	GND	Ground Pin

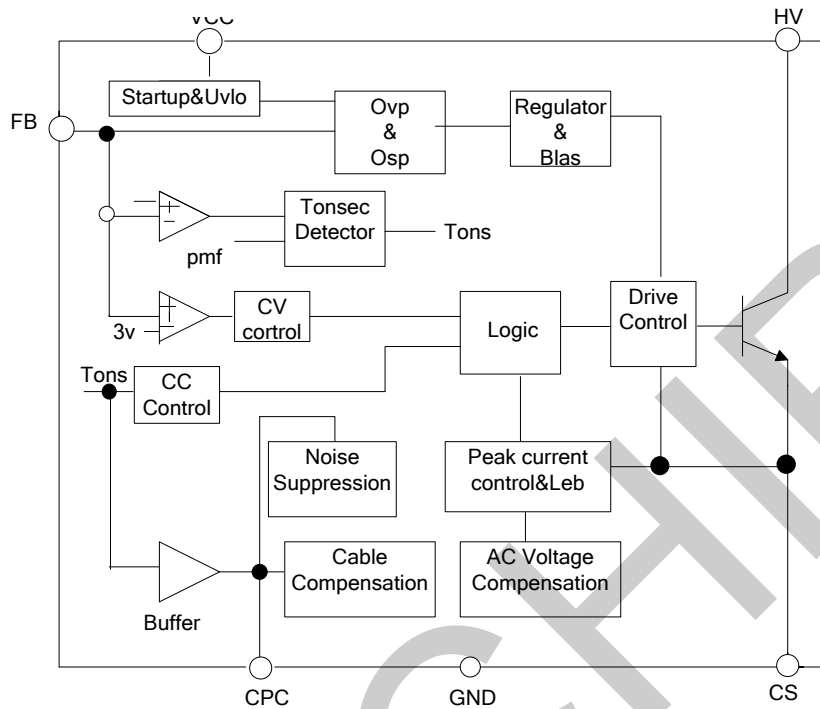
**FUNCTIONAL BLOCK DIAGRAM**

**ABSOLUTE MAXIMUM RATINGS**

Internal power BJT Vcbo	800V
BJT Ic Peak Current:	1.5A
VCC Pin Voltage	8.6V
FB Pin Voltage	7V
Others Pin Voltage	Vcc+0.3V
Operating Temperature (Tj)	0~+140°C
Storage Temperature	-55~+150°C
ESD (Human Body Mode)	3000V
Lead Temperature	+260°C/10S

Note 1: Stresses beyond those listed under “absolute maximum ratings” may cause permanent damage to the device. Under “recommended operating conditions” the device operation is assured, but some particular parameter may not be achieved.

**ELECTRICAL CHARACTERISTICS** (Unless otherwise specified, parameters are measured by setting GND Potential as zero Potential in room Temp.)

Parameter	Symbol	Conditions	Min	Type	Max	Unit
<b>VCC UVLO SECTION</b>						
Star-up Voltage	VCC-ON		7.5	8.0	8.8	V
Shut down	VCC OFF		3.0	3.3	3.5	V
Star-up Current	IStar			0.2	1	uA
Operating Current	ICC			500	800	uA
Max. Operating Voltage	VCC-MAX				8.5v	
<b>CURRENT SENSE SECTION</b>						
Maximum Current to CS PIN	ICS		3.4	4	5	uA
Current Sense Threshold Voltage	VCS				510	mV
Leading Edge Blanking	TLEB	Ic=1mA		500		nS
<b>FEED BACK INPUT SECTION</b>						
FB Reference Voltage	VREF-FB		2.85	2.9	2.95	V
Input Resistance of FB Pin	RFB		1.2	1.5	2	MΩ
Feedback Threshold Voltage	VFB-MAX				5	V
<b>POWER BJT SECTION</b>						
Collector-emitter Saturation Voltage	VCE sat	Ic=1000mA Ib=200mA			0.6	V
Collector-Base Voltage	VCBO		800			V
<b>OVER TEMPERATURE PROTECTION(OTP)</b>						
Shutdown Temperature	TSHD N		135	140	145	°C
Temperature Hysteresis	THYS		125	130	135	°C

**FUNCTION DESCRIPTION**

HT2802D is specially designed for the charger/adaptor of small power digital products. To use PSR control technology to provide accurate (CV/CC) characteristics. The controller works in PFM mode and the switching frequency can be automatically adjusted as per the load. Optimized driving circuit greatly promotes withstand voltage of the power BJT and minimizes the switching loss, so as to make the circuit have excellent converting efficiency

**CONSTANT VOLTAGE(CV) OPERATION**

When the circuit is operates in CV area, FB will detect the output voltage when the power BJT turn-off through the sensing voltage by auxiliary winding of the transformer, to make the output voltage stablized in the fixed value. In the turn-on period of the output rectifier diode D, it's given the output winding voltage and auxiliary winding voltage as follows

$$V_{AUX} = \frac{N_{AUX}}{N_s} \cdot (V_o + V_d) \text{ -----(5)}$$

Vaux : auxiliary winding voltage; Nb: subsidiary winding turns; NS: output winding turns; Vd: forward voltage drop of output rectifier diode

FB will test the auxiliary winding voltage while the power BJT off-time to regulate the output voltage. In order to avoid the peak influence happens in power BJT turn-off resulting from the leakage inductance of the transformer, and considering the accuracy of sampling voltage, FB captures the auxiliary winding detection sampling points as below:

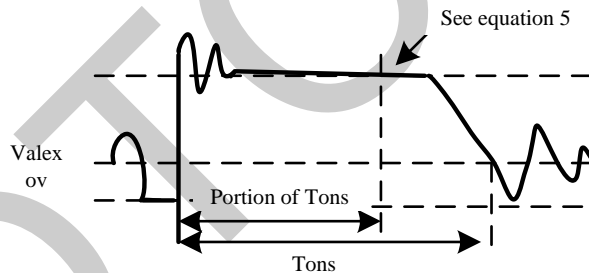

**CONSTANT CURRENT(CC ) OPETATION**

HT2802D control circuit is requested the converter operating in DCM . In CC operation mode , the CC control circuit will fix the proportion between the Tons and Toffs produced by diode rectifier D. When Tons time, the primary energy of the transformer will be converted to the secondary winding, via the rectifier diode then charge the output capacitor and supply load simultaneously.

When Toffs, the primary coil stores the energy, the output filter capacitor makes load discharge. In CC operation area, HT2802D switch frequency will follow the output load direct ratio contro detected by FB Voltage

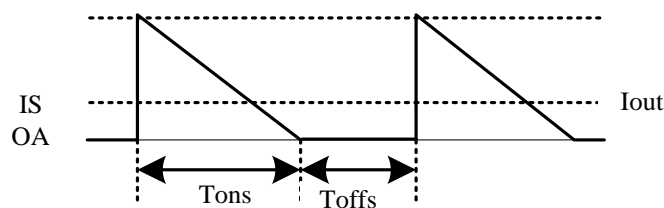

The secondary rectifier diode peak current is determined by the peak current of primary-side inductance which also affects the output current. The corresponding relation between the primary peak current and the secondary peak current is as follows

$$I_{pks} = \frac{N_p}{N_s} \cdot I_{pk}$$

$I_{pk}$ : primary peak current ;  $N_p$ : primary winding turns;  $N_s$ : secondary winding turns;  
 $I_{pks}$ : secondary peak current

And primary inductance peak current is determined by Pin 4 to RCS resistance, the primary inductance peak current and RCS resistance are in inverse proportion, so only need to adjust CS resistance to achieve different output currents. Output current  $I_{out}$  and primary current are given by

$$I_{out} = \frac{1}{2} \cdot I_{pks} \cdot \frac{T_{ons}}{T_{ons} + T_{offs}}$$

$I_{out}$ : Output current;  $T_{ons}$ : secondary rectifier diode on-time;  $T_{offs}$ : secondary rectifier diode off-time

### OUTPUT CABLE COMPENSATION

HT2802D built-in output cable drop compensation circuit. When it outputs different loads, the cable drop compensation circuit provides cable drop voltage compensation which is in fixed proportion with output voltage. The internal circuit will generate one cable drop compensation signal once have one 100nF capacitor connected with external Pin CPC

### PROTECTIVE FUNCTIONS

In order to guarantee a safe and reliable circuit to all occasions, HT2802D built-in rich protection circuits, such as OCP, OVP, FB open-loop protection etc. as intergration. Once abnormality, it will come into protection mode

### TYPICAL APPLICATION CIRCUIT

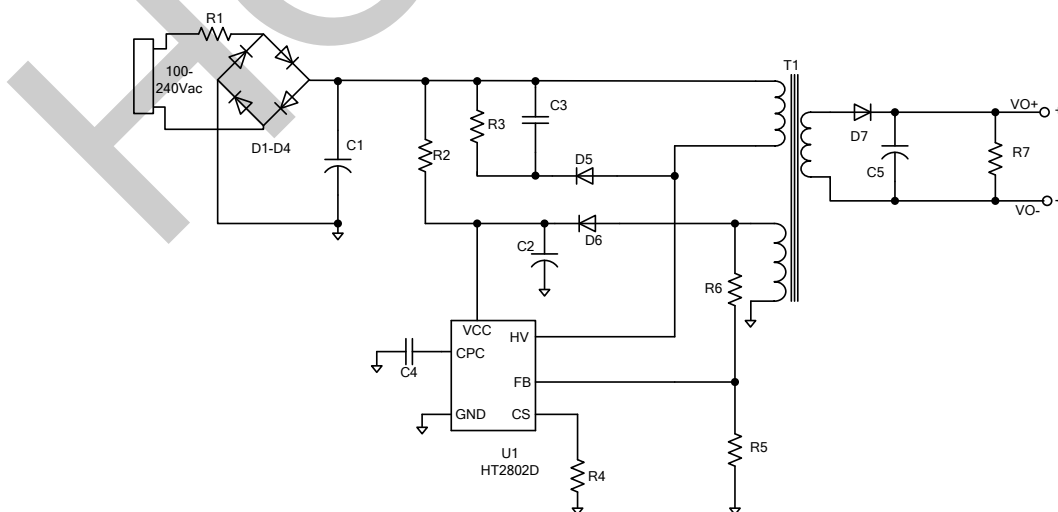

Typical application of HT2802D (Output: 5V/2.0A)

**Packaging Information**

## DIP7 Package

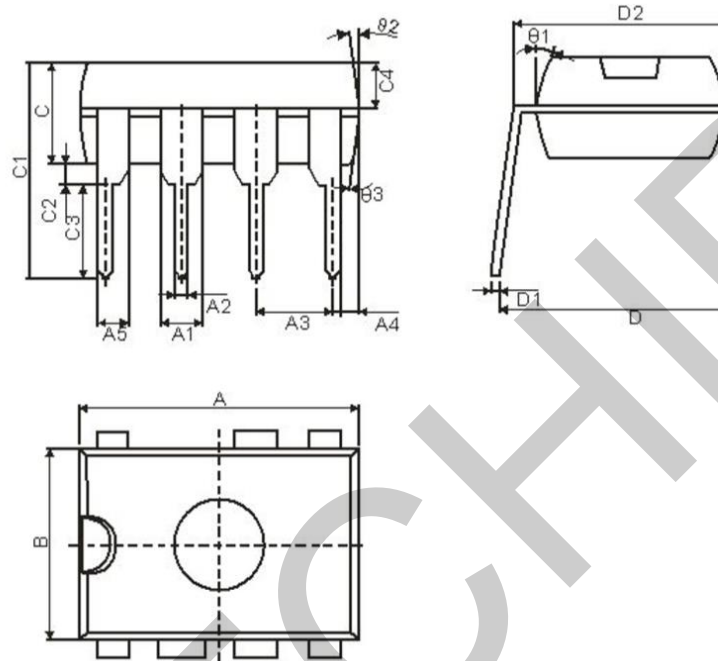

Symbol	Dimensions in Millimeters		Dimensions in Inches	
	Min	Max	Min	Max
A	9.00	9.50	0.354	0.374
B	6.10	6.60	0.240	0.260
C	3.0	3.4	0.118	0.134
A1	1.474	1.574	0.058	0.062
A2	0.41	0.53	0.016	0.021
A3	2.44	2.64	0.096	0.104
A4	0.51TYP		0.02TYP	
A5	0.99TYP		0.04TYP	
C1	6.6	7.30	0.260	0.287
C2	0.50TYP		0.02TYP	
C3	3.00	3.40	0.118	0.134
C4	1.47	1.65	0.058	0.065
D	7.62	9.3	0.300	0.366
D1	0.24	0.32	0.009	0.013
D2	7.62TYP		0.3TYP	

**PACKAGE DESCRIPTION**

## Device Marking and Ordering Information

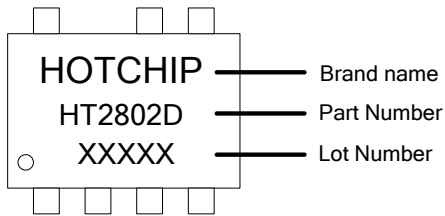

Package	Chip surface marking	Purchasing the device name
DIP7 Pb-free	HT2802D	HT2802D

**IMPORTANT NOTICE**

- ✧ HOTCHIP reserves the right to alter its products without prior notification. For the most up-to-date information, please visit our web site at <http://www.hotchip.com.cn>.
- ✧ HOTCHIP assumes no liability for the issues about the industrial standard, licenses and the right of the third party caused by the electric circuit and chart. The schematic is just for typical application, is not for the specialized mass production application.
- ✧ The export authorization from government is needed when the product or its derivative product do not agree with the Wassenaar Arrangement or other international agreement.
- ✧ Any copy of these information without our permission to print for other uses is forbidden.
- ✧ HOTCHIP's products are not authorized for use as critical components in life support devices or systems, such as motion machine, medical machine, security system, gas equipment, airplane or any other conveyance.
- ✧ HOTCHIP cannot avoid fault or losing efficacy, though we will do the best to improve the quality and reliability. The customers use the products should go through the security design, such as the redundant design, fire protection design, failure protection about the secondary disasters, fire or other related damage.
- ✧ HOTCHIP will continuously provide better products for the customers by all our heart